

# Environmental Impact Assessment

## Establishment of a Regional Wastewater Collection System and Treatment Plant for San Fernando and Environs



Volume 1 of 2  
Report

CEC 1597/2006

July 2010



CEC 1597/2006

# **EIA for a Wastewater Collection System and Treatment Plant in San Fernando and Environs**

---

**Prepared by:**

AECOM

18 Alcazar Street

St. Clair, Port of Spain, Trinidad, W.I.

[www.aecom.com](http://www.aecom.com)

868 628 9710 tel

868 628 0862 fax

**Project Number:**

60118683

**Date:**

July, 2010



## Statement of Qualifications and Limitations

The attached Report (the “Report”) has been prepared by AECOM Canada Ltd. (“Consultant”) for the benefit of the client (“Client”) in accordance with the agreement between Consultant and Client, including the scope of work detailed therein (the “Agreement”).

The information, data, recommendations and conclusions contained in the Report (collectively, the “Information”):

- is subject to the scope, schedule, and other constraints and limitations in the Agreement and the qualifications contained in the Report (the “Limitations”)
- represents Consultant’s professional judgement in light of the Limitations and industry standards for the preparation of similar reports
- may be based on information provided to Consultant which has not been independently verified
- has not been updated since the date of issuance of the Report and its accuracy is limited to the time period and circumstances in which it was collected, processed, made or issued
- must be read as a whole and sections thereof should not be read out of such context
- was prepared for the specific purposes described in the Report and the Agreement
- in the case of subsurface, environmental or geotechnical conditions, may be based on limited testing and on the assumption that such conditions are uniform and not variable either geographically or over time

Consultant shall be entitled to rely upon the accuracy and completeness of information that was provided to it and has no obligation to update such information. Consultant accepts no responsibility for any events or circumstances that may have occurred since the date on which the Report was prepared and, in the case of subsurface, environmental or geotechnical conditions, is not responsible for any variability in such conditions, geographically or over time.

Consultant agrees that the Report represents its professional judgement as described above and that the Information has been prepared for the specific purpose and use described in the Report and the Agreement, but Consultant makes no other representations, or any guarantees or warranties whatsoever, whether express or implied, with respect to the Report, the Information or any part thereof.

The Report is to be treated as confidential and may not be used or relied upon by third parties, except:

- as agreed in writing by Consultant and Client
- as required by law
- for use by governmental reviewing agencies

Consultant accepts no responsibility, and denies any liability whatsoever, to parties other than Client who may obtain access to the Report or the Information for any injury, loss or damage suffered by such parties arising from their use of, reliance upon, or decisions or actions based on the Report or any of the Information (“improper use of the Report”), except to the extent those parties have obtained the prior written consent of Consultant to use and rely upon the Report and the Information. Any damages arising from improper use of the Report or parts thereof shall be borne by the party making such use.

This Statement of Qualifications and Limitations is attached to and forms part of the Report and any use of the Report is subject to the terms hereof.



## Executive Summary

### 1. Project Introduction and Background

The Water and Sewerage Authority of Trinidad and Tobago (WASA) are proposing to expand and upgrade the wastewater infrastructure in San Fernando and Environs to improve the level of service for existing and new customers. The end result of the project will be an integrated wastewater system that provides a cost-effective and sustainable solution to wastewater collection, treatment and disposal for San Fernando and Environs that significantly improves the water quality in rivers and surrounding environment, protects public health and improves the quality of life for the residents. The relevance and urgency of the project is made more evident with the knowledge that this entire region continues to undergo rapid industrial and commercial development as well as population growth.

The main benefits of the project include:

- Reduction in public health risk associated with untreated wastewater discharges into drains, rivers and other water courses.
- Improvement of water quality in the Guaracara, Marabella, Vistabella and Cipero Rivers that currently receive wastewater discharges.
- Overall improvement to the surrounding environment through the proper collection, treatment and disposal of wastewater that is otherwise presently adversely impacting the environment.
- Potential for production of up to 45 mega litres per day (ML/d) of reclaimed water that is suitable for irrigation and other non-potable uses in the area.
- Overall improvement in the quality of life for citizens of San Fernando and Environs.

The San Fernando Wastewater project involves the establishment of a new wastewater treatment plant (WWTP) centrally located at the existing San Fernando WWTP site, the integration of existing sewers into a centralized collection system, and the provision of new sewers to service all un-sewered properties within the wastewater catchment area.

An overview of the San Fernando Wastewater project area, showing the location of the San Fernando WWTP, the project boundaries, watercourses and major roads, is illustrated in Figure 1. Figure 2 displays all existing WWTPs and sewerage areas within the San Fernando Wastewater project area.



Figure 1 San Fernando Wastewater Catchment Area



Figure 2 Existing Sewered Areas (shaded) and WWTPs in San Fernando Project Area



The new WWTP is to replace all nine existing plants within the project boundaries. The plants being eliminated are:

- San Fernando WWTP
- Harmony Hall WWTP
- Palmiste WWTP
- Gulf City Development WWTP
- Sunkist WWTP
- Westpark WWTP
- San Fernando Technical Institute WWTP
- Marabella Secondary School WWTP
- Corinth Housing Development Retention Pond

The main objectives of the San Fernando Wastewater Project are:

- Identify the most effective arrangement of the wastewater systems within the City of San Fernando and Environs from a technical, operational and financial perspective.
- Prepared detailed design, cost estimates, implementation schedules and tender documents for the rehabilitation and expansion of the wastewater collection system within the San Fernando Wastewater Catchment area.
- Prepare detailed designs, cost estimates, implementation schedules for the construction of a central WWTP.
- Design the new WWTP to ensure the effluent complies with the Water Pollution Rules, 2001 (as amended).
- Design the new WWTP with the provision to produce an effluent suitable for reuse in agricultural irrigation, industrial uses and indirect augmentation of potable water supplies.
- Design the collection system and treatment facility to a design horizon of 2035.

## 2. Existing Situation

The City of San Fernando is currently serviced by a wastewater collection, treatment and disposal system built in the 1960s and owned and operated by WASA. The collection system has approximately 72 km of piping and services an estimated 25,000 people in San Fernando proper. The existing San Fernando WWTP was designed to handle a wastewater flow of 20 ML/d. A septage receiving station was added in the 1980s.

The areas outside of the existing San Fernando collection system have experienced significant development over the past several years. Some of the planned housing developments built since 1970 have installed sewers and package WWTPs that are operated either privately or, in the case of HDC developments, have been taken over by WASA in recent years. Over time, most of these facilities have fallen into a state of disrepair or have been abandoned. Approximately 70% of the developed areas are serviced by individual on-lot disposal systems, the majority of which are either partially functioning or not at all. Water quality testing of the four main rivers running through the project area has verified high levels of faecal coliform bacteria, which is an indicator organism for raw wastewater contamination.

### 3. Project Description

The San Fernando Wastewater project comprises a centralized and integrated sewer collection system and a single WWTP. All wastewater will be conveyed to the new San Fernando WWTP located at the end of Riverside Drive, Gulf View at the site of the existing San Fernando WWTP (Figure 3). A new alternative access road to the site is proposed through the Gulf View Industrial Park. The new treatment plant will be constructed where the existing plant structures are located and extending west. All the land is currently occupied and owned by WASA.



**Figure 3 Existing and Proposed WWTP Site**

#### 3.1. Wastewater Treatment Plant

The design effluent criteria for the WWTP is based on treating the wastewater to meet US EPA Guidelines for Water Reuse and California and Florida state regulations governing reclaimed water. The new plant will be capable of producing consistently high quality effluent that can be safely re-used for agricultural irrigation, and industrial uses. In the event that the treated effluent is not reclaimed it will be discharged to the Ciperu River. These standards exceed those stipulated in the EMA Water Pollution Rules 2001 (as amended) for Inland Surface Water Discharges (Table 1).



**Table 1 San Fernando WWTP Effluent Criteria**

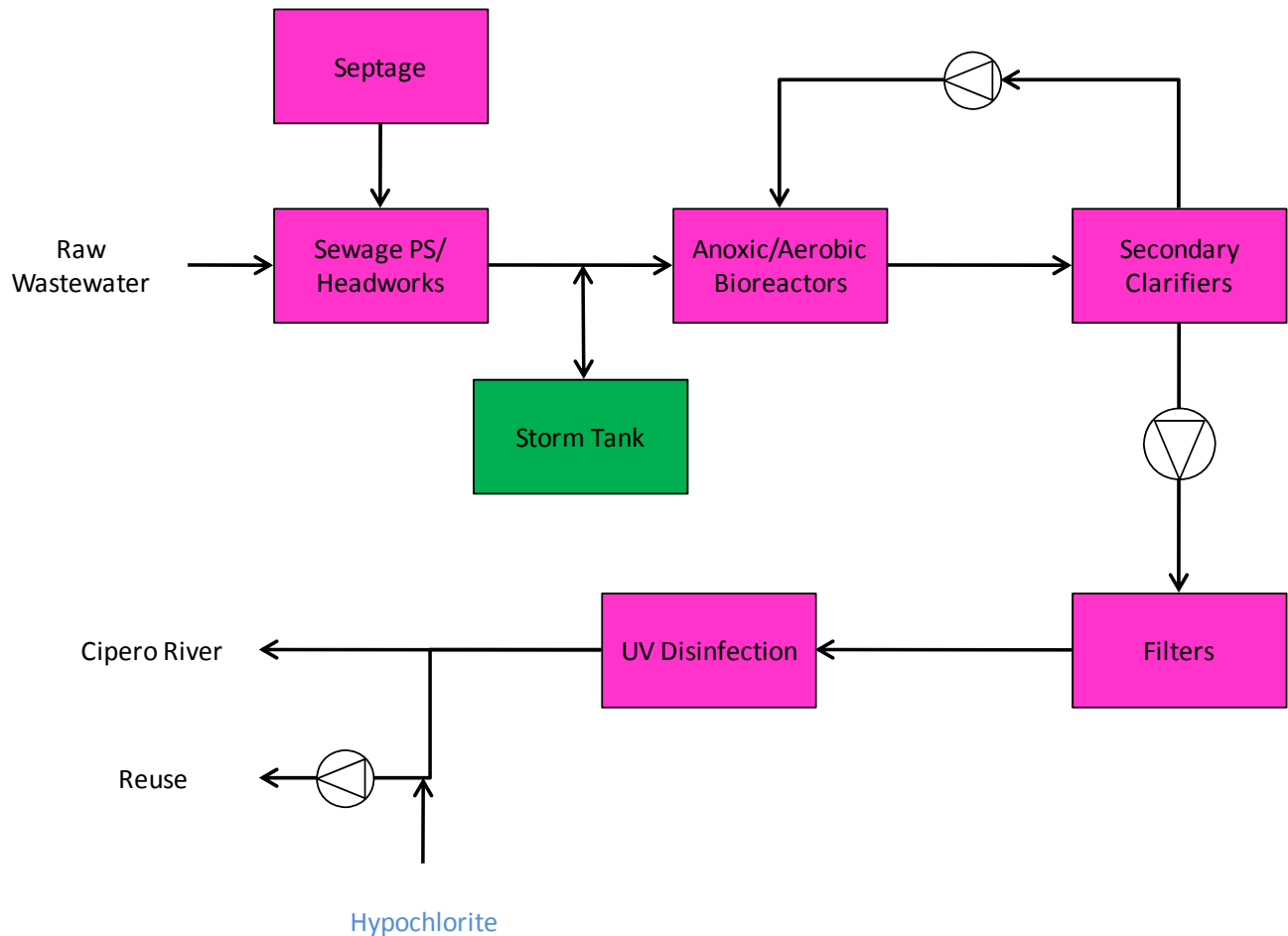
Parameter	EMA Water Pollution Rules 2001 (as amended) for Inland Surface Water Discharge	Design Effluent Criteria
BOD (mg/L)	30	< 20(CBOD)
TSS (mg/L)	50	< 5
Dissolved Oxygen (mg/L)	> 4	> 4
Temperature °C	< 3	< 3
Ammonia-Nitrogen (mg/L)	10	< 10
Total Nitrogen (mg/L)	-	< 15
Total Phosphorus (mg/L)	< 5	< 5
Faecal Coliform (CFU/100ml)	400	Max: 25/100 mL and 75% samples below detection
pH	6-9	6 to 8.5
Total Residual Chlorine (mg/L)	1	<1

The WWTP will be sized to treat the 2035 design year average dry weather flow (ADWF) of 45 ML/d and peak dry weather flow (PDWF) of 90 ML/d through secondary and tertiary treatment. The influent pump station, influent screens and grit removal facilities (headworks) will be capable of handling the design peak wet weather flow (PWWF) of 158 ML/d. Flows in excess of the PWWF will be diverted to storm water storage facilities on-site until secondary treatment capacity is available. Treated effluent will be either re-used beneficially or discharged to the Ciperu River. Screenings and grit will be washed, dewatered and hauled off site for disposal in a landfill. Waste solids from the activated sludge treatment process will be aerobically digested, dewatered, and hauled off site for beneficial use or landfill disposal.

The treatment scheme of the liquid stream includes the following unit processes:

- Influent pumping
- Septage receiving
- Fine screening
- Grit removal
- Storm water storage
- Activated sludge aeration (Bioreactors)
- Secondary clarification
- Return activated sludge (RAS) pumping
- Filtration
- UV disinfection
- Chlorination (if reused)

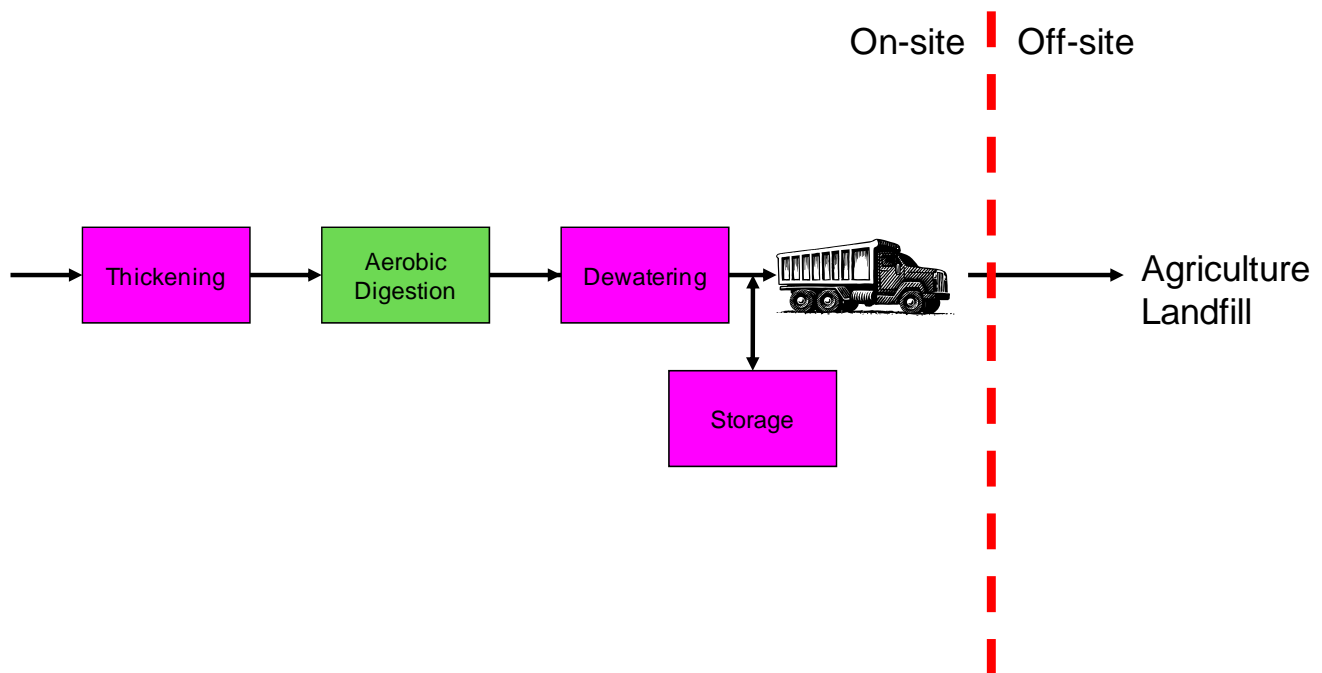
The liquid stream flow schematic is illustrated in Figure 4.



**Figure 4 WWTP Liquid Stream Flow Schematic**

The waste solids from the liquid treatment process scheme will be treated to meet WASA requirements as defined to be suitable for beneficial reuse as agricultural land application. The treatment involves the waste activated sludge being thickened and then aerobically digested. The digested solids will be dewatered and hauled off site.

The existing anaerobic digesters will be converted to aerobic digesters. The dewatering facility will consist of a two-story building with belt filter presses located on the second floor. The lower level will be an open area for loading trucks. The facility will also include polymer storage, mixing and feed equipment. Temporary storage of the dewatered cake will be provided on-site in covered trailers. The dewatered cake will be taken off-site for either agricultural land application or landfilled. A flow schematic of the solids process is illustrated in Figure 5.



**Figure 5 WWTP Solid Stream Flow Schematic**

### 3.2. Collection System

The extent of the collection system for the San Fernando Wastewater Project is defined by the San Fernando regional wastewater catchment boundaries. The regional catchment was established in 2008 as part of WASA's wastewater master plan to divide the country into a number of regional catchments for servicing. The boundaries of the San Fernando regional catchment were refined under the present project through an extensive field investigation programme with inputs from WASA, TCPD, San Fernando City Corporation, and other relevant stakeholders. The San Fernando regional catchment covers an area of 42 km<sup>2</sup> and the boundaries are depicted in Figure 1.

The San Fernando regional catchment is divided into a number of subcatchments based on the following characteristics:

- Natural topography
- Drainage
- Physical boundaries

Dividing the entire catchment into a number of smaller sub-catchments allows for a phased implementation of the project based on availability of financing, cash-flow constraints and also allows prioritization of serviced areas to optimize the environmental benefits over the period of execution. The subcatchment boundaries are illustrated in Figure 6.



Figure 6 Subcatchments of the San Fernando Wastewater Project



The proposed wastewater collection system consists of a gravity sewer system with pipe sizes ranging from 200 mm to 1500 mm diameter. The sewers collect all wastewater from the project area and convey it to the new WWTP. When the depth of the gravity sewer exceeds the design limit, a wastewater lift station is introduced to pump or “lift” the wastewater back up to a higher level. The main objectives of the collection system design included:

- Sewer all properties within the project area.
- Minimize the amount of pumping so as to reduce the level of maintenance required to operate and maintain the system.
- Minimize disruption through the use of trenchless technology for the larger trunk sewers, major road crossings, river crossings and congested areas.

The proposed San Fernando collection system is illustrated in Figure 7. A summary of the proposed sewer pipe lengths per subcatchment is shown in Table 2.

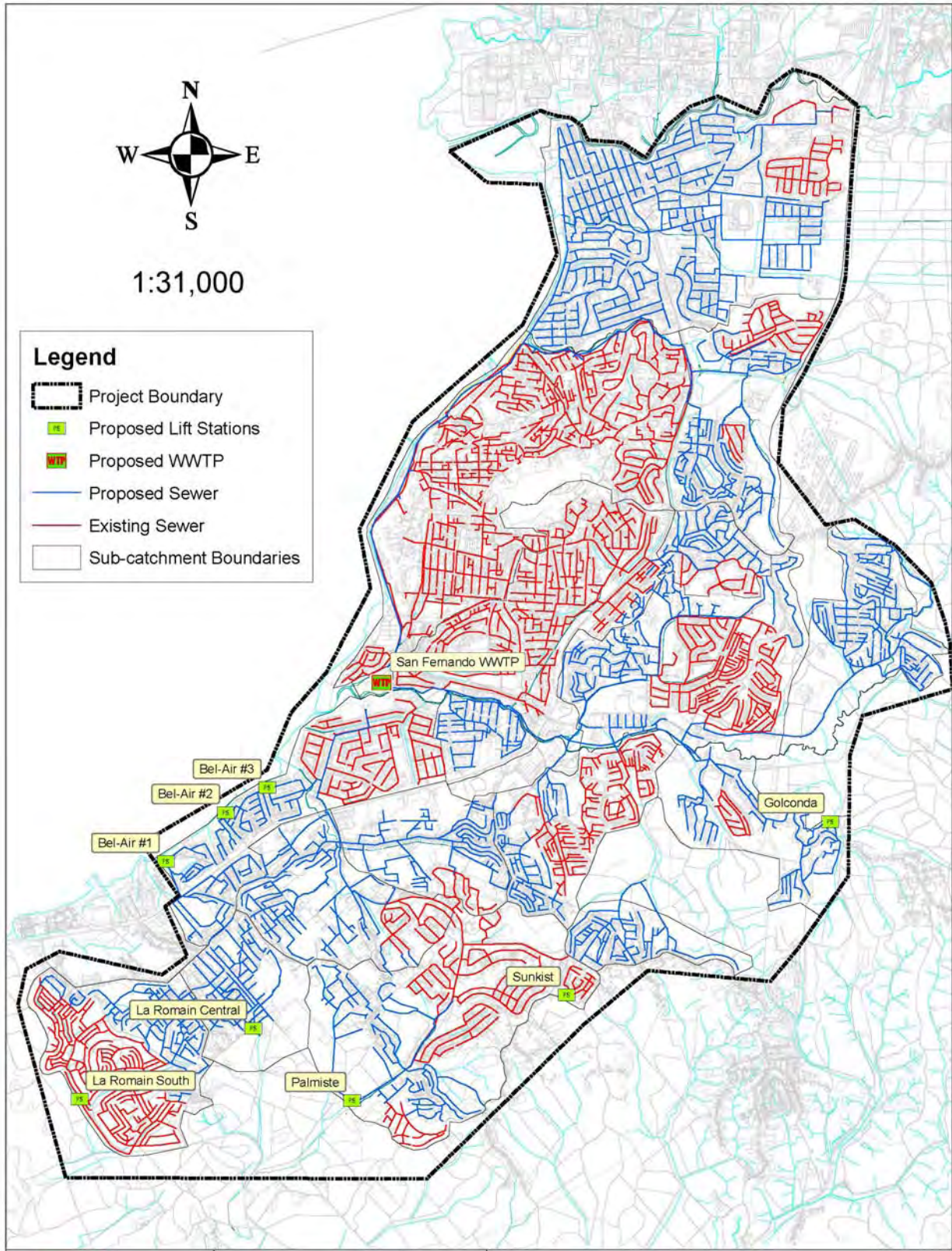


Figure 7 Proposed San Fernando Wastewater Collection System

**Table 2 Proposed Collection System Pipe Length by Subcatchment**

Subcatchment	Pipe Length (km)
Marabella	48
Tarouba-Cocoyea	16
Cocoyea South	7
Pleasantville-Corinth	16
Vistabella-Gulf	6
San Fernando South	4
Ste. Madeleine	18
Bel Air - Gulf View	13
Green Acres	6
Duncan Village	11
Union Hall	8
Retrench-Golconda	11
La Romain North	15
La Romain Central	11
La Romain South	11
Palmiste South	13
Picton	9
<b>Total New Sewer</b>	<b>224</b>

### 3.3. Construction Phasing of Project

The San Fernando project will most likely be constructed in phases to accommodate operation of existing facilities, minimize disruption in the community, and match funding capabilities. The primary objective is to achieve maximum benefit during the first phase of construction by building the new WWTP and connecting areas with existing sewers.

The proposed Phase I would consist of two construction contracts (Figure 8) as follows:

- Contract No. 1 – New San Fernando WWTP
- Contract No. 2 – Trunk sewers constructed using trenchless techniques plus connecting sewers between existing sewer areas and the new trunk lines.

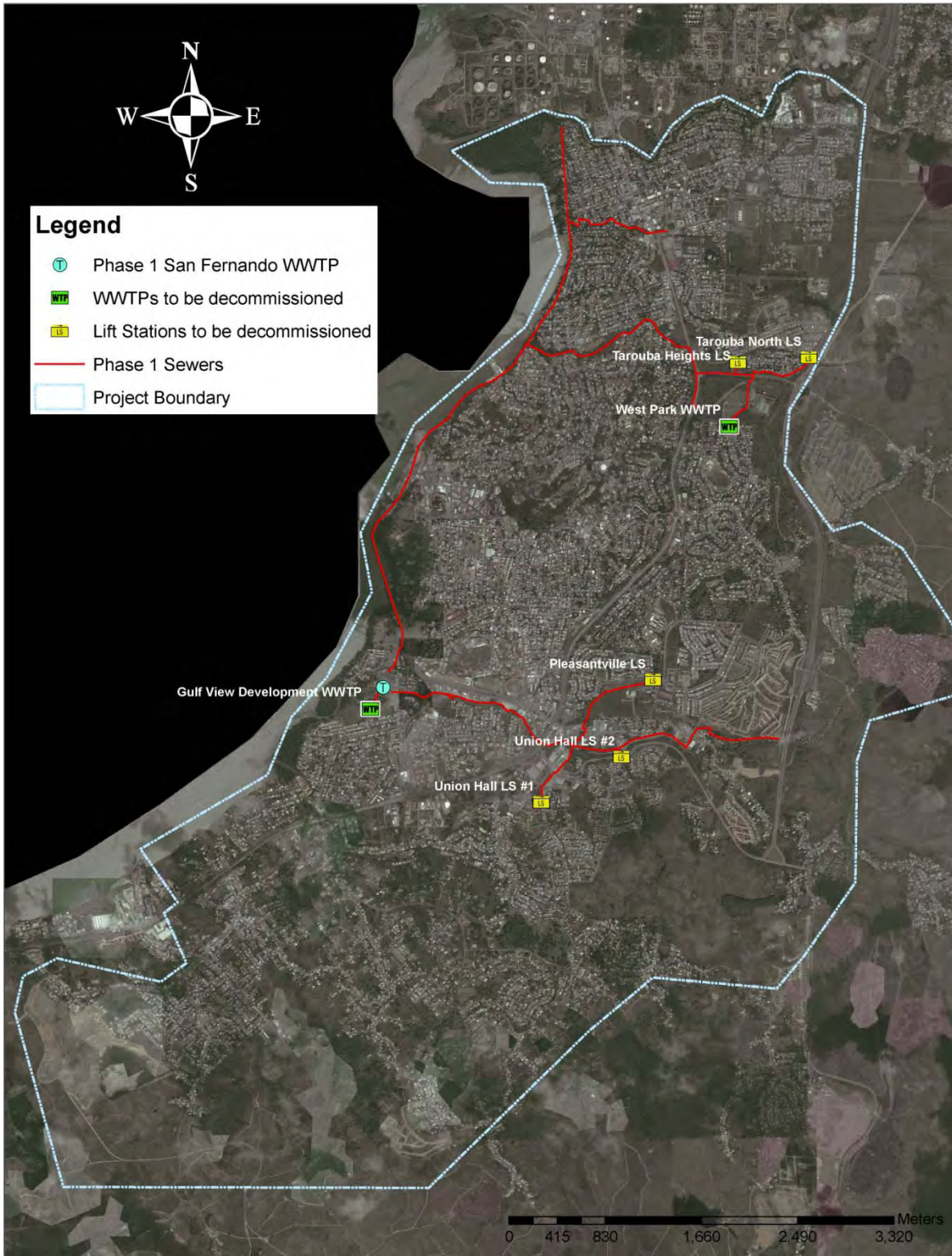


Figure 8 Phase I Construction Contract: WWTP and Collection System





At completion of Phase I, wastewater entering the existing San Fernando sewer system and most of the sewered areas that naturally drain to the Cipero River would be treated in the new WWTP. The initial ADWF to the plant would be approximately 16 ML/d, which is 36 percent of the ultimate design ADWF of 45 ML/d. This equates to a service population of 40,035 out of a total 2035 population of 111,600.

The remainder of the collection system construction will be prioritized and phased based on the available funding. The first priority would be to construct the trunk sewer from the WWTP, south through Gulf View to Dumfries Road, and south along Dumfries Road to Palmiste Avenue. Completion of this trunk sewer would provide conveyance capacity to connect all the subcatchments located south of the Cipero River. Priorities would be assigned based on several factors including connection of existing sewered areas, e.g., Palmiste South; environmental issues such as anticipated water quality improvement; and construction costs.

#### 4. Environmental Impact Assessment Report

An application for a Certificate of Environmental Clearance (CEC) for this project was submitted to the Environmental Management Authority (EMA) in August 2006 in accordance with CEC Rules 2001. The EMA determined that the application required an Environmental Impact Assessment (EIA) study to assist in its determination of the application since the project was considered to have the potential for environmental and social impacts. The Final Terms of Reference (TOR) for the EIA in support of WASA's application (CEC 1597/2006), were provided to WASA on 21 November 2006. AECOM Canada Limited was commissioned by WASA in March 2008 to conduct an EIA in accordance with the Final TOR issued by the EMA, and to carry out detailed designs for the San Fernando Wastewater Project.

The objective of an EIA is to:

- Provide information which allows developers to maximize benefits of the project to themselves, the environment and local and national community.
- Allow regulators to ensure that the positive impacts of the project are maximized and the negative impacts eliminated or minimized to acceptable levels.
- Allow the community and the wider public to gain an understanding of the project and its impacts on them and their socio-economic and physical environment, and to have their views and concerns addressed.

This EIA report consists of one volume containing the main text and a second volume containing a number of appendices which documents a detailed description of the biophysical and social environment in which the WWTP and collection system will be constructed and operated. The EIA report lists the potential impacts each component of the project will have on the environment. These impacts were assessed and the most appropriate mitigation measures were determined and incorporated in the design of the San Fernando WWTP and collection system. An environmental monitoring and management plan was also developed as a means of prevention, minimisation and remediation of any impacts the San Fernando Wastewater Project may have on the biophysical and human environment.



#### 4.1. Baseline Biophysical and Social Environment

The biophysical environment is largely influenced by anthropogenic activities including agriculture, industry and residential and commercial development. Few natural areas remain within the project boundaries. The remaining undeveloped areas are categorised as low vegetation with scrub, agricultural, and forested areas.

Water quality testing was carried out on the Ciperó, Guaracará, Marabella, Vistabella Rivers, and Alley's Creek to assess the effects of the existing situation on the receiving rivers and streams in the San Fernando wastewater catchment. The results of the water quality testing programme indicated high levels of faecal coliforms in the rivers (Table 3). The presence of faecal coliform is a strong indicator of raw sewage and the concentrations measured were indicative of significant wastewater discharges in most of the rivers in the San Fernando wastewater catchment. The Ciperó River had the highest concentration of faecal coliform out of all the rivers tested. Faecal coliform levels were also generally higher in the wet season sampling event.

**Table 3 Fecal Coliform Data (CFU/100ml) from River Quality Sampling**

River Name	Dry Season (June 3, 2009)	Wet Season (October 20, 2009)	EMA WPR First Schedule Quantity Defined as a Pollutant
Guaracará	Inland – 360	Inland – 8,000	>100
	Gulf – 315	Gulf – 32,000	
Marabella	Inland – 8,000	Inland – 11,000	
	Gulf – 49,000	Gulf – 46,000	
Vistabella	(River Dry)	Inland – 11,000	
		Gulf – >200,000*	
Ciperó	Inland – 179,000	Inland – 198,000	
	Gulf – 120,000	Gulf – >200,000*	
Ally's Creek	(River Dry)	112,000	

Note: \* - too numerous to count (TNTC)

Flora and fauna studies were conducted and a land use category map was developed to assist in the studies. The results indicate over 60% of the project area is currently developed by human activities (Table 4).

**Table 4 Land Use Categories in San Fernando Wastewater Catchment**

Land Use Category	Area (km <sup>2</sup> )	Percentage of Study Area (%)
Commercial and Residential	8.07	49
Low Density Buildings	0.88	5
New Developments	1.16	7
Abandoned Sugarcane	0.99	6
Scrub and Agriculture	3.63	22
Mangrove Forest	0.21	1
Riparian Forest	0.16	1
National Parks	0.21	1
Close Cropped Lawns	0.49	3
Other	0.8	4
<b>TOTAL</b>	<b>16.6</b>	<b>100</b>

Upon examination of the flora habitat it was recommended that the natural remnants of mangrove and riparian forest be preserved. During fauna studies, a total of 84 bird species were observed in the fauna study and a few vertebrate populations. Based on the research conducted it was concluded that some vulnerable and rare species can visit the project area. A fish survey conducted in the rivers and in the coastal waters surrounding the San Fernando Wastewater catchment area found Guppies, Black Tilapia, Catfish and Mullet. It is likely that the poor water quality in the rivers is contributing to the relatively low diversity of fish species found as compared to other rivers in Trinidad. Table 5 summarizes this data.

**Table 5 Fauna Survey Species Observed**

Fauna Classification	Number of Species Observed
Bird	84
Fish	10
Butterfly	12
Amphibian	2
Reptile	3

## 4.2. Potential Impacts and Mitigation

An important component of the EIA report is the identification of potential impacts that the project may have on the surrounding environmental. Project-environment interactions were ascertained based on the design of the San Fernando WWTP and collection system and the environmental baseline assessment of the project area. An environmental interaction is any element of a facility's activities, products, operations or services which can or will interact with the environment. These interactions



and their effects may be continuous in nature, occur periodically, or may be associated with specific events, such as emergencies. Some interactions may be beneficial, such as a reduction in odours, however, the primary objective of this EIA study is to identify and minimize the negative impacts. The project-environment interactions considered are identified in Table 6. Accidents and emergency situations were studied separately.

**Table 6 Project-Environment Interaction with Affected Environment**

Project-Environment Interaction	Affected Environment					
	Water	Air	Soil	Biological	Transportation	Other Social
Storage/staging and stockpiling of materials, and chemicals <sup>C,O</sup>	x	x	x		x	x
Obtain easements <sup>C</sup>						x
Use of labour <sup>C,O</sup>						x
Transportation to and from site (personnel, equipment, machinery) <sup>C,O</sup>		x			x	
Use of construction equipment and machinery <sup>C</sup>		x	x	x		x
Use of lighting <sup>C,O</sup>				x		x
Storage and disposal of construction debris and waste <sup>C</sup>	x				x	x
Use of chemicals, coatings and paint <sup>C,O</sup>		x				
Ground excavation, vegetation clearing, ground compaction, trenching, piling <sup>C</sup>	x	x	x	x	x	
Alteration of grade and drainage patterns <sup>C</sup>	x		x			
Construction of WWTP <sup>C</sup>	x	x	x			
Construction of Collection System Sewer <sup>C</sup>	x	x	x		x	
Water supply management <sup>O</sup>	x					
Effluent release to catchments <sup>C,O</sup>	x			x		x
WWTP Equipment operation <sup>O</sup>		x				
Sludge Management <sup>C,O</sup>		x	x		x	
Odour Management <sup>C,O</sup>		x				

Note: C = construction phase; O = operation phase

These project-environment interactions were evaluated and the impact to water, air, soil, biology, transport and social parameters was discussed. The impact of each variable on these environmental parameters was reviewed according to magnitude, scope, direction and degree of irreversibility. The mitigation measures assimilated in the design as well as those institutionalised outside of the design



were presented and the residual impact was discussed post-mitigation. A summary of the proposed project impacts before and after (pre and post) mitigation is displayed in (Table 7).

**Table 7 Summary of Impacts Pre-and Post Mitigation**

Classification of Potential Impact	Project Phase	Potential Impact	Unmitigated Magnitude of Impact	Post-Mitigation Residual Impact
Air Quality	Construction	Exhaust Emissions	Minor on site, negligible off site Negative	Minor on site, Negligible off site Negative
		Airborne dust and particles	Minor Negative	Minor on site, Negligible off-site Negative
		Odours	Minor to Moderate Negative	Negligible Negative
	Operation	Exhaust Emissions	Minor Positive	-
		Airborne dust and particles	Minor Negative	Negligible Negative
		Odours	Minor to Moderate Negative	Negligible Negative
Noise	Construction	Noise from vehicles, equipment, and construction	Minor to Moderate Negative	Minor to Moderate Negative
	Operation	Operational Noise	Moderate Negative	Negligible Negative
Water	Construction	Land Clearing and excavation along watercourses	Minor Negative	Negligible Negative
		Release of untreated wastewater from San Fernando WWTP	Major Negative	Negligible Negative
	Operation	Release of untreated wastewater from San Fernando WWTP	Major Negative	Negligible Negative
		Water Quality Improvement	Major Positive	-
		Potable Water Use	Minor Positive	-
Soil	Construction	Erosion	Moderate Negative	Negligible to Minor Negative
		Soil Compaction	Minor Negative	Negligible Negative
		Sludge Management	Minor Negative	Negligible Positive
	Operation	Erosion from Outfall	Moderate Negative	Negligible Negative



**Table 7 Summary of Impacts Pre-and Post Mitigation (continued)**

Classification of Potential Impact	Project Phase	Potential Impact	Unmitigated Magnitude of Impact	Post-Mitigation Residual Impact
Flora	Construction	Species Loss	Minor to Major Negative	Negligible to Minor Negative
		Dust Deposition	Minor to Negligible Negative	Negligible Negative
	Operation	Landscaping	Negligible	Neutral
Fauna	Construction	Habitat Loss	Moderate Negative	Negligible to Minor Negative
		Habitat Modification	Moderate Negative	Negligible to Minor Negative
	Operation	Habitat Modifications	Moderate Positive	-
		Aquatic Fauna Species Growth	Major Positive	-
		Lighting	Minor Negative	Negligible Negative
Transportation	Construction	Traffic increase to site	Minor Negative	Minor Negative
		Traffic disruptions from collection system road right of way construction	Major Negative	Minor to Moderate Negative
	Operation	Traffic increase to site	Negligible to Minor Negative	Negligible Negative
Social	Construction	Labour Requirement	Minor Positive	-
		Land Acquisition	Minor Negative to Positive (site dependant)	Negligible Negative to Positive
		Health and Injuries	Minor to Major Negative	Minor to Negligible Negative
		Blocked properties and visual intrusion from construction material	Minor Negative	Negligible Negative
		Use of lighting	Minor Negative	Negligible Negative



**Table 7 Summary of Impacts Pre-and Post Mitigation (continued)**

Classification of Potential Impact	Project Phase	Potential Impact	Unmitigated Magnitude of Impact	Post-Mitigation Residual Impact
Social	Operation	Labour Requirement	Minor Negative	Negligible Negative
		Economics – Change to Wastewater Fees	Major for Country Negative	Major Neutral to Negative
		Use of lighting	Minor	Negligible Negative
		Water Quality Improvement	Major Positive	-
Cumulative	Construction	Other construction projects within San Fernando Area	To be studied on a case-by-case basis throughout construction	To be studied on a case-by-case basis throughout construction
		Utility upgrade or installation at same time as collection system work	Minor to Major Positive	-
	Operation	Water Quality Improvement	Major Positive	-

A major positive impact from the San Fernando Wastewater Project is the improvement in surface water quality in the region, as a result of the untreated wastewater being properly collected and treated at the new WWTP. Cleaning up the waterways in the catchment area will result in a habitat improvement for aquatic species, improved public health and decrease in waterborne illnesses for humans, and overall improvement in the quality of life.

The most significant negative impact is disruption of traffic flow during construction. Traffic disruption has potential to affect over 10% of the San Fernando and environs population and will impact localized areas throughout the construction process. A significant portion of the construction will be within road right-of-ways. Mitigation of traffic impacts will be accomplished by utilizing trenchless technology in high traffic roadways, and a comprehensive traffic management plan that includes provisions for proper detours and signage, provision of access to all businesses and properties, restrictions on construction hours, and limits on the amount of construction that can occur at any one location. Once these mitigation measures are utilized in the construction, the unmitigated major negative impact becomes a mitigated minor to moderate negative impact.

The cumulative impacts of simultaneous activities were evaluated and include:

- Existing and proposed construction projects
- Utility installation and upgrade



The cumulative impact of these activities can be moderate on a regional scale. However, effective liaison between the respective agencies and stakeholders conducted during the design phase of the San Fernando Wastewater Project has identified this project to all agencies and stakeholders, and with proper planning and communication, would mitigate this impact to a minor scale.

The potential for accidents and plant malfunctions was examined as part of the EIA. The probability and impact of the following events were categorised;

- Spills
- Process Upset
- Natural Hazards
- Power Failures
- Fires
- Injury/Death

Post-mitigation, the residual impacts ranged from negligible to minor in magnitude. The key principle governing the reduction of impacts and encompassing mitigation measures was discovered to be adherence to national rules and regulations and contract specifications and guidelines.

### 4.3. Environmental Monitoring and Management

The granting of a CEC could be accompanied by a requirement for an environmental monitoring and management plan. The potential impacts were identified and appropriate mitigation measures were incorporated into the design, however, there are some residual impacts that would require participation of external institutions for prevention and minimisation to be achievable.

Consequently, an environmental monitoring and management plan was formulated and specified for inclusion in the tender documents as a contract requirement for the Contractor to implement. The monitoring plan covers both environmental and social issues including; the terrestrial and aquatic environment, air, land/soil, odour, traffic and public health and safety. Environmental management during construction was incorporated in the form of a specification that deals with proper waste storage and disposal, drainage and siltation control, and protection of the natural and man-made environment. The procedure by which the Contractor and all other personnel will comply with the relevant regulations and the stipulations of the San Fernando Wastewater Project is outlined in the environmental monitoring and management plan. The enforcement of the plan will chiefly be attained via direct and constant supervision by WASA and the assigned resident engineer and site supervision team who will ensure that all specifications of the contract are adhered to and protection of the environment and worker health and safety is achieved.

## 5. Summary

The proposed San Fernando Wastewater Project will have a major positive impact to the rivers and surrounding environment in San Fernando and Environs through the proper collection, treatment and disposal of wastewater that is presently discharging into rivers and watercourses. The project will also decrease waterborne diseases, safeguard public health and improve the overall quality of life of the residents.





There are no significant long term negative impacts to the social or biophysical environment, only short term impacts during construction. Most of the impacts are confined to WWTP site and collection system right of ways. The impact of traffic disruption during construction has been reduced with the use of trenchless technology in high-traffic areas, and implementation of a traffic management plan, to be enforced by the Contractor, WASA and the Ministry of Works and Transport. Construction of the proposed San Fernando Wastewater Project is a vital component to WASA's overall master plan of improving the level of wastewater services to all residents of Trinidad and Tobago.



## Acronyms

Acronym	Meaning
24/7	24 hours a day, 7 days a week
µm	Micrometre
ADWF	Average Dry Weather Flow
APR	Air Pollution Rules
AS	Activated Sludge
ASTM	American Society for Testing and Materials
AWWA	American Water Works Association
BFP	Belt Filter Press
BOD	Biological Oxygen Demand
Bq	Becquerel
CBOD	Carbonaceous Biological Oxygen Demand
CCTV	Closed Circuit Television
CEC	Certificate of Environmental Clearance
CFU	Coliform Forming Units
CITES	Convention on International Trade in Endangered Species of Wild Fauna and Flora
Co	Company
CO <sub>2</sub>	Carbon Dioxide
COD	Chemical Oxygen Demand
CSO	Central Statistical Office
d	Day
DAF	Dissolved Air Flotation
dB	Decibels
dBA	Decibels (A-weighted)
DF	Denitrifying Filter
DO	Dissolved Oxygen
E	East
ED	Enumeration District
EIA	Environmental Impact Assessment
EIS	Environmental Impact Statement
EMA	Environmental Management Authority
USEPA	United States Environmental Protection Agency
ESA	Environmentally Sensitive Areas
ESS	Environmentally Sensitive Species
eTeck	Evolving Technologies and Enterprise Development Company of Trinidad and Tobago
F	Filtration
FLOW	Columbus Communications Trinidad Limited
FM	Geological formation
GHG	Greenhouse Gases



Acronym	Meaning
GORTT	Government of the Republic of Trinidad and Tobago
GP	Grinder Pump
GPS	Global Positioning System
H <sub>2</sub> O	Water
HDC	Housing Development Corporation of Trinidad and Tobago
HDD	Horizontal Directional Drilling
HMI	Human-Machine Interface
hr	Hour
HRT	Hydraulic Retention Time
HSE	Health, Safety and the Environment
I&C	Instrumentation and Control
I&I	Infiltration and Inflow
Inc.	Incorporated
ITCZ	Inter Tropical Convergence Zone
IUCN	International Union for Conservation of Nature
kg	Kilograms
km	Kilometres
km <sup>2</sup>	Square kilometres
kW	Kilowatt
L	Litres
L <sub>eq</sub>	Equivalent sound pressure level
L <sub>peak</sub>	Peak sound pressure level
Lpcd	Litres per capita per day
LS	Lift Station
LSA	Land Settlement Agency
Ltd	Limited
m	Metres
m <sup>2</sup>	Square metres
m <sup>3</sup>	Cubic metres
M	Million
masl	Metres above sea level
MBBR	Moving Bed Biofilm Reactor
MBR	Membrane Bioreactor
mg	Milligrams
ml	Millilitres
mm	Millimetres
ML	Mega litres
MLSS	Mixed Liquor Suspended Solids
MODSEC	San Fernando Central Secondary School
MOWT	Ministry of Works and Transport
MPN	Most Probable Number
MSDS	Material Safety Data Sheets



Acronym	Meaning
mW	Milliwatt
N	North
NEP	National Environmental Policy
NGC	National Gas Company of Trinidad and Tobago
NH <sub>3</sub>	Ammonia
NPCR	Noise Pollution Control Rules
O&M	Operation and Maintenance
O <sub>2</sub>	Oxygen
ODPM	Office of Disaster Preparedness and Management
OFR	Over Flow Rate
OSH	Occupational Safety and Health
OTR	Oxygen Transfer Rate
Pa	Pascal
pe	Population Equivalent
Petrotrin	Petroleum Company of Trinidad and Tobago
PDWF	Peak Dry Weather Flow
PLC	Programmable Logic Controllers
PM <sub>2.5</sub>	Particulate Matter (weighing $\leq 2.5 \mu\text{m}$ )
PM <sub>10</sub>	Particulate Matter (weighing $\leq 10 \mu\text{m}$ )
PWWF	Peak Wet Weather Flow
RAS	Return Activated Sludge
ROW	Right-of-way
s	Second/s
S	South
SBR	Sequencing Batch Reactors
SFWWTP	San Fernando Wastewater Treatment Plant
SGD	Small Gravity Diameter
SHE	Safety, Health and the Environment
SLR	Solids Loading Rate
SND	Simultaneous-Nitrification-Denitrification
SOTR	Standard Oxygen Transfer Rate
SOUR	Specific Oxygen Uptake Rate
SPAW	Specially Protected Areas and Wildlife
SPL	Sound Pressure Level
SRT	Solids Retention Time
STEP	Septic Tank Effluent Pump
SWD	Side Water Depth
SWMCOL	Solid Waste Management Company Limited
T&T	Trinidad and Tobago
T&TEC	Trinidad and Tobago Electricity Commission
TCPD	Town and Country Planning Division
TDH	Total Dynamic Head



Acronym	Meaning
TF	Trickling Filter
TGR	Trinidad Government Railway
TKN	Total Kjeldahl Nitrogen
TN	Total Nitrogen
TP	Total Phosphorus
TOR	Terms of Reference
TSP	Total Suspended Particulates
TSS	Total Suspended Solids
TSTT	Telecommunication Service of Trinidad and Tobago
UDECOTT	Urban Development Corporation of Trinidad and Tobago Limited
UN	United Nations
U.S.	United States
UV	Ultraviolet
U.W.I.	University of the West Indies
VSS	Volatile Suspended Solids
W	West
WAS	Waste Activated Sludge
WASA	The Water and Sewerage Authority
WPR	Water Pollution Rules
WWTP	Wastewater Treatment Plant



## Glossary

Term	Definition
Activated Sludge	Biomass produced in raw or settled wastewater by the growth of microorganisms in aeration tanks in the presence of dissolved oxygen. Microorganisms become “activated” in a selected environment and breakdown the incoming wastewater.
Aerobic digester	Treatment of waste activated sludge in an aerated tank where organics are oxidised to carbon dioxide, water and ammonia and air is supplied from blowers.
Alluvial	Loose, unconsolidated sediment.
Archaeology	The study of remnants of a human society through recovery of materials left behind.
Avifauna	The bird population of a region or area.
Belt Filter Press (BFP)	Continuous-feed sludge dewatering devices that involve the application of chemical conditioning, gravity drainage and mechanically applied pressure between porous belts to dewater sludge.
Benthopelagic	Living on or occurring at bottom or at mid-level depth in a body of water
Bioreactor	Tanks in which biochemical reactions take place. Organics in wastewater are converted to respiratory products (water and oxygen) and cellular material. Nutrients (Ammonia, nitrates, nitrites, Phosphorus etc.) can also be selected and reduced to defined limits.
Biosolids	By-product of wastewater treatment, also called treated sludge which comprises of 1 to 10% solids.
Blower	Mechanical device that supplies air.
Census	The procedure by which information about a population is acquired on a national level, in Trinidad and Tobago this is done every ten years.
Clarifier	A settling tank used to separate solids from liquids.
Collection System	The network of sewer pipes and lift stations which convey wastewater collected from properties to the wastewater treatment plant.
Regional/City Corporation	Corporate body administering the operations of the city or community. This includes; drainage, roads and public places.
Demographics	Characteristics of a population which explains its social composition, chiefly age, sex, religion and ethnicity.
Denitrification	A biological process employed to convert the nitrate-nitrogen in effluent from the activated sludge into elemental nitrogen gas.
Dissolved Air Flotation (DAF)	Process of removing solids from liquid by releasing fine air bubbles into the wastewater, the solid particles adhere to the bubbles, and float to the top where it is then removed.
Earthworks	The man-made alternations to the natural topography of a site, specifically grading and backfilling.
Effluent	Treated wastewater released into the natural environment by wastewater treatment plants.
Enumeration District	A defined geographical area comprising approximately 150 to 200



Term	Definition
	households.
Fault	Planar rock fracture along which the rocks on either side have moved relative to the other.
Filtration	The process by which suspended solids are removed.
Geological Formation (FM)	A rock unit with similar characteristics, particularly type of sediment or fossils.
Grit	Heavier inorganic solids contained in wastewater.
Hydrometric Region	Physical zone exposed with similar hydrological components, typically rainfall and groundwater.
Inter Tropical Convergence Zone (ITCZ)	Equatorial zone of low pressure where trade winds from the northern and southern hemisphere converge and uplifted.
Lift Station	Facility at which wastewater is pumped from one area to a next. It is generally needed when gravity sewer pipes become too deep to construct due to gravitational and hydraulic controls.
Liquefaction	Reduction of strength and stiffness of soil as a result of earth movements.
Marl	Lime-rich mud.
Mitigation	The moderation, prevention or reduction of an impact by addressing the issue before the consequence.
Mixed Liquor	Mixture of raw wastewater and microorganisms in a biological mass.
Mudflat	Coastal wetlands comprising of mud, sand or gravel formed by deposition of sediments from rivers or/and tides in sheltered areas.
Nitrification	The biological conversion of ammonia to nitrate-nitrogen.
Particulate Matter	Mixture of small particles and liquid droplets comprising of acids, organic chemicals, soils and dust.
Petit Careme	Weather phenomenon experienced during the wet season specifically in September and October categorised by higher temperatures.
Polymers	A coagulant added to wastewater to help separate out solids from liquids.
Primary Treatment	Initial treatment where the heavier and more easily settleable solids in raw wastewater are removed. These include large solids that settle quickly such as sand, gravel and floating materials.
Return Activated Sludge (RAS)	Sludge collected in the secondary clarifiers and returned to the bioreactor to ensure sufficient mixed liquor concentration of the activated sludge is maintained to obtain required treatment.
Riparian	Vegetation adjacent to or connected with a water course
Runoff	Water that flows off from a man-made surface or structure.
Screenings	Organic and inorganic materials large enough to be removed on bar racks.
Scrub	Short, dense vegetation made of shrubs, ferns and young trees.
Scum	Floatable materials skimmed from the surface of primary and secondary settling tanks. May contain grease, detergents, soaps, food wastes, hair, paper.
Secondary Clarifier	A settling tank that separates mixed liquor from a bioreactor into RAS and clarified effluent.



Term	Definition
Secondary Treatment	Wastewater treatment where biological content of wastewater is degraded.
Sedge	Grass-like or low level trees.
Sedimentation	The process by which sediments are deposited or settled in a rock unit.
Seismic	Relating to or cause by earthquake activity.
Septage	Sewage at individual on-site sewage systems, mainly septic tanks and cesspits.
Sewage	Domestic wastewater primarily from human wastes (toilet, sink, shower, etc.).
Shale	Fine-grained mud which is characterised by parallel thin layers.
Socio-Economic	The combination of social and economic factors such as; employment and education.
Specification	A precise requirement of a contract to be fulfilled via the delivery of a material, product or service.
Stakeholder	A person or organization that has a direct or indirect investment in the project because the stakeholder will be affected by any decisions or outcomes of the project.
Stratigraphy	Layering or strata of a rock unit
Syncline	A fold in a rock unit that dips downward or is “U-shaped”.
Tertiary Treatment	Following secondary treatment, additional level of treatment to meet the stipulated criteria, including nutrient removal and disinfection.
Tsunami	A series of ocean waves.
Ultraviolet (UV) Disinfection	The reduction of microorganisms in water by exposing the bacteria to UV radiation which damages the genetic structure of the organism disabling their ability to reproduce.
Waste Activated Sludge (WAS)	Excess sludge from the RAS which is used to maintain the food to microorganism ratio. WAS is treated.
Wastewater	All water that is processed including domestic and industrial wastewater.
Wastewater Catchment	Physical area defined by topographic, drainage and wastewater collection system in which all the wastewater is treated at one facility.
Watershed	An area of land in which water flows toward the same water course or river.
Wet Well	Chamber or tank in which wastewater is collected before it is treated or pumped.





# Table of Contents

Statement of Qualifications and Limitations

Executive Summary

Acronyms

Glossary

Page

- 1. Introduction..... 1-1**
  - 1.1 Overview..... 1-1
  - 1.2 Project Background ..... 1-1
  - 1.3 San Fernando Wastewater Treatment Plant and Collection System ..... 1-2
  - 1.4 Scope of the EIA..... 1-4
  - 1.5 Report Structure..... 1-4
  - 1.6 List of Report Preparers and EIA Project Team..... 1-5
- 2. Legislative, Regulatory, and Policy Framework..... 2-1**
  - 2.1 Introduction..... 2-1
  - 2.2 Environmental Management Act..... 2-1
    - 2.2.1 Environmental Management Authority ..... 2-1
    - 2.2.2 Certificate of Environmental Clearance Rules ..... 2-2
    - 2.2.3 Water Pollution Rules..... 2-3
    - 2.2.4 Noise Pollution Control Rules ..... 2-6
    - 2.2.5 Draft Air Pollution Rules..... 2-8
    - 2.2.6 Environmentally Sensitive Areas Rules ..... 2-8
    - 2.2.7 Environmentally Sensitive Species Rules ..... 2-9
    - 2.2.8 Draft Waste Management Rules ..... 2-10
  - 2.3 Water and Sewerage Act ..... 2-10
    - 2.3.1 WASA – Water and Wastewater Design Guidelines ..... 2-12
  - 2.4 Forest Act..... 2-14
  - 2.5 Fisheries Act ..... 2-15
  - 2.6 Plant Protection Act..... 2-15
  - 2.7 Conservation of Wildlife Act..... 2-16
  - 2.8 Occupational Safety and Health Act..... 2-16
  - 2.9 Trinidad and Tobago Bureau of Standards..... 2-17
    - 2.9.1 Specification for the Liquid Effluent from Domestic Wastewater Treatment Plants into the Environment ..... 2-18
    - 2.9.2 Specification for the Effluent from Industrial Processes Discharged into the Environment..... 2-18
  - 2.10 National Policies..... 2-19
    - 2.10.1 National Environmental Policy..... 2-20
    - 2.10.2 National Wetlands Policy ..... 2-21
    - 2.10.3 Draft National Protected Areas Policy ..... 2-22
    - 2.10.4 Draft National Forest Policy ..... 2-23
  - 2.11 Multilateral Agreements/Conventions..... 2-24
  - 2.12 Approval Agencies ..... 2-25
    - 2.12.1 The Environmental Commission ..... 2-26
    - 2.12.2 Town and Country Planning Division ..... 2-26



2.12.3 Municipal Corporations ..... 2-27  
2.12.4 Ministry of Works and Transport ..... 2-28

**3. Project Description ..... 3-1**

3.1 Objective ..... 3-1  
3.2 Project Background ..... 3-1  
3.3 Project Boundaries ..... 3-2  
3.4 Land Use and Population ..... 3-4  
3.5 Existing Sewered Areas ..... 3-6  
3.5.1 San Fernando City Sewerage System ..... 3-9  
3.5.2 Palmiste Development Sewerage System ..... 3-10  
3.5.3 Union Hall Development Sewerage System ..... 3-10  
3.5.4 Gulf View Development Sewerage System ..... 3-10  
3.6 Present Wastewater Volume and Strength ..... 3-10  
3.7 Design Effluent Flows and Criteria ..... 3-14  
3.7.1 Design Flows ..... 3-14  
3.7.2 Design Effluent Criteria ..... 3-15  
3.8 Overall Scope of Works ..... 3-17  
3.9 Wastewater Treatment Plant Scope of Works ..... 3-17  
3.9.1 Influent Pump Station ..... 3-23  
3.9.2 Septage Receiving ..... 3-24  
3.9.3 Fine Screens ..... 3-25  
3.9.4 Grit Removal ..... 3-26  
3.9.5 Flow Measurement and Wet Weather Storage ..... 3-27  
3.9.6 Storm Water Storage ..... 3-27  
3.9.7 Bioreactors ..... 3-28  
3.9.8 Secondary Clarifiers ..... 3-29  
3.9.9 Filtration ..... 3-29  
3.9.10 UV Disinfection ..... 3-30  
3.9.11 Secondary Sludge Pumping ..... 3-31  
3.9.12 Sludge Thickening ..... 3-32  
3.9.13 Aerobic Digestion ..... 3-33  
3.9.14 Sludge Dewatering and Loadout ..... 3-33  
3.9.15 Wastewater Reuse Option ..... 3-35  
3.9.16 Chlorination Facility ..... 3-35  
3.9.17 Polymer Addition ..... 3-35  
3.9.18 Utility Requirements ..... 3-35  
3.9.19 Design Summary ..... 3-36  
3.10 Collection System Scope of Works ..... 3-45  
3.10.1 Sewer Piping Network ..... 3-45  
3.11 Wastewater Lift Stations ..... 3-67  
3.12 Pre-Construction Activities ..... 3-67  
3.12.1 Land Acquisition ..... 3-67  
3.13 Construction Phase ..... 3-68  
3.13.1 Project Phasing ..... 3-68  
3.13.2 Sewer Location and Alignment ..... 3-72  
3.13.3 Crossing Clearance to Sewers ..... 3-72  
3.13.4 Pipe Bedding, Backfill and Reinstatement ..... 3-72  
3.13.5 Sewer Installation Techniques ..... 3-73



- 3.13.6 Site Grading and Drainage..... 3-75
- 3.13.7 Erosion Control..... 3-75
- 3.13.8 Traffic to Site..... 3-75
- 3.14 Operation of San Fernando Wastewater System ..... 3-76
  - 3.14.1 Labour Requirements..... 3-76
  - 3.14.2 Treatment Plant Process Control ..... 3-76
  - 3.14.3 Instrumentation and Control..... 3-77
  - 3.14.4 Waste Management ..... 3-77
- 3.15 Demolition and Decommissioning of Existing Facilities..... 3-78
  - 3.15.1 Demolition Process..... 3-79
  - 3.15.2 Demolition Operations..... 3-79
  - 3.15.3 Removal Operations ..... 3-79
  - 3.15.4 Abandonment Operations ..... 3-80
  - 3.15.5 Disposal ..... 3-80
- 3.16 Demolition and Decommissioning of New San Fernando Wastewater Project..... 3-80
- 4. Analysis of Alternatives..... 4-1**
  - 4.1 Wastewater Treatment Plant Location..... 4-1
  - 4.2 Type of Collection System ..... 4-1
    - 4.2.1 Low Pressure System..... 4-2
    - 4.2.2 Vacuum System..... 4-2
    - 4.2.3 Small Diameter Gravity (SDG) System ..... 4-3
    - 4.2.4 Centralized Conventional Gravity Sewer System ..... 4-3
  - 4.3 Selection of Wastewater Treatment System..... 4-4
    - 4.3.1 Liquids Treatment Process Options..... 4-4
    - 4.3.2 Comparison of the Liquid Stream Options..... 4-14
    - 4.3.3 Solids Treatment Process Options ..... 4-17
    - 4.3.4 Comparison of the Solids Stream Options..... 4-23
  - 4.4 No Action Alternative..... 4-24
- 5. Biophysical Environment Setting..... 5-1**
  - 5.1 Introduction..... 5-1
  - 5.2 Climate..... 5-1
    - 5.2.1 Wind Speed and Wind Direction..... 5-2
    - 5.2.2 Temperature..... 5-3
    - 5.2.3 Humidity ..... 5-4
    - 5.2.4 Precipitation..... 5-5
  - 5.3 Natural Hazards ..... 5-7
    - 5.3.1 Floods ..... 5-7
    - 5.3.2 Bush Fires ..... 5-8
    - 5.3.3 Hurricanes..... 5-8
    - 5.3.4 Earthquakes..... 5-10
    - 5.3.5 Tsunami Hazards ..... 5-12
  - 5.4 Soils ..... 5-13
    - 5.4.1 San Fernando WWTP ..... 5-13
    - 5.4.2 San Fernando Collection System..... 5-14
  - 5.5 Geology..... 5-18
  - 5.6 Topography..... 5-21
  - 5.7 Drainage..... 5-21



5.8	Water Quality.....	5-24
5.8.1	Faecal Coliforms.....	5-36
5.8.2	BOD <sub>5</sub> and COD.....	5-37
5.8.3	Dissolved Oxygen.....	5-37
5.8.4	Total Suspended Solids.....	5-37
5.8.5	Ammonia.....	5-37
5.8.6	Total Phosphorus.....	5-38
5.8.7	Metals.....	5-38
5.9	Biological Environment.....	5-38
5.9.1	Land Use of Project Area.....	5-38
5.10	Flora.....	5-41
5.11	Fauna.....	5-42
5.12	Noise Quality.....	5-78
5.13	Ambient Air Quality.....	5-82
<b>6.</b>	<b>Social Environmental Conditions.....</b>	<b>6-1</b>
6.1	Introduction.....	6-1
6.2	Study Area.....	6-1
6.3	Methodology.....	6-2
6.4	Historical Development of Study Area.....	6-3
6.5	Land Use.....	6-4
6.6	Archaeology Sites.....	6-7
6.7	Employment.....	6-9
6.8	Recreational Activities.....	6-12
6.9	Public Buildings and Institutions.....	6-12
6.9.1	Schools.....	6-12
6.9.2	Community Centres.....	6-12
6.9.3	Courts.....	6-13
6.9.4	Libraries.....	6-13
6.10	Population Demographics.....	6-15
6.10.1	General.....	6-15
6.10.2	Age.....	6-16
6.10.3	Religion.....	6-17
6.10.4	Ethnicity.....	6-18
6.11	Quality of Life.....	6-20
6.11.1	Education.....	6-20
6.11.2	Housing.....	6-22
6.11.3	Water Supply.....	6-22
6.11.4	Sewer Collection.....	6-23
6.11.5	Electricity Supply.....	6-25
6.11.6	Telecommunications.....	6-27
6.11.7	Summary.....	6-28
6.12	Social Services.....	6-28
6.12.1	Health.....	6-29
6.12.2	Transport.....	6-29
6.12.3	Education.....	6-30
6.12.4	Police.....	6-31
6.12.5	Fire.....	6-31
6.13	Social Survey.....	6-31



- 6.13.1 Methodology..... 6-31
- 6.13.2 Socio-Economics ..... 6-32
- 6.13.3 Project Awareness ..... 6-32
- 6.13.4 Perceived Impacts and Concerns ..... 6-33
- 6.14 Road Traffic Survey ..... 6-35
- 7. Key Stakeholder and Public Consultations..... 7-1**
  - 7.1 Requirements of CEC TOR ..... 7-1
  - 7.2 Introductory Meetings with Key Stakeholders ..... 7-2
  - 7.3 Key Stakeholder Meeting ..... 7-3
  - 7.4 Public Consultations ..... 7-4
    - 7.4.1 Public Consultation # 1 ..... 7-4
    - 7.4.2 Public Consultation # 2..... 7-6
  - 7.5 Conclusion ..... 7-8
- 8. Impact Analysis and Mitigation Measures..... 8-1**
  - 8.1 Methodology..... 8-1
    - 8.1.1 Impacts Assessment..... 8-1
    - 8.1.2 Mitigation Measures ..... 8-3
  - 8.2 Project- Environment Interactions ..... 8-3
  - 8.3 Air Quality Impacts and Mitigation..... 8-5
    - 8.3.1 Construction Phase ..... 8-5
    - 8.3.2 Operation Phase ..... 8-7
  - 8.4 Noise Impacts and Mitigation..... 8-9
    - 8.4.1 Construction Phase ..... 8-9
    - 8.4.2 Operational Phase ..... 8-10
  - 8.5 Water Impacts and Mitigation ..... 8-10
    - 8.5.1 Construction Phase ..... 8-10
    - 8.5.2 Operation Phase ..... 8-12
  - 8.6 Soil and Land Impacts and Mitigation..... 8-13
    - 8.6.1 Construction Phase ..... 8-13
    - 8.6.2 Operation Phase Erosion..... 8-14
  - 8.7 Biological Impacts and Mitigation ..... 8-14
    - 8.7.1 Construction Phase: Flora..... 8-14
    - 8.7.2 Construction Phase: Fauna ..... 8-15
    - 8.7.3 Operation Phase: Flora ..... 8-16
    - 8.7.4 Operation Phase: Fauna ..... 8-16
  - 8.8 Transportation Impacts and Mitigation ..... 8-17
    - 8.8.1 Construction Phase ..... 8-17
    - 8.8.2 Operation Phase ..... 8-22
  - 8.9 Social Impacts and Mitigation ..... 8-22
    - 8.9.1 Construction..... 8-22
    - 8.9.2 Operation ..... 8-24
  - 8.10 Cumulative Impacts and Mitigation ..... 8-26
    - 8.10.1 Existing and Proposed Construction Projects..... 8-26
    - 8.10.2 Utility Installation or Upgrade..... 8-27
    - 8.10.3 Untreated Wastewater Discharges ..... 8-27
  - 8.11 Summary of Impacts and Mitigation ..... 8-27
  - 8.12 Accidents and Malfunctions ..... 8-33



8.12.1	Spills .....	8-33
8.12.2	Process Disruption .....	8-35
8.12.3	Natural Hazards .....	8-36
8.12.4	Power Failure .....	8-36
8.12.5	Fire .....	8-37
8.12.6	Injury/Death .....	8-37
<b>9.</b>	<b>Environmental Monitoring and Management Plan .....</b>	<b>9-1</b>
9.1	Environmental Monitoring .....	9-1
9.2	Social Monitoring .....	9-1
9.3	Management .....	9-2
9.3.1	Protection of Environment Specification .....	9-2
9.3.2	Traffic Control Specification .....	9-3
9.3.3	Waste Management Plan .....	9-4
9.3.4	Mitigation Action Plan .....	9-5
9.3.5	Emergency Response Plan .....	9-5
9.4	Compliance .....	9-5
<b>10.</b>	<b>Bibliography .....</b>	<b>10-1</b>

## List of Figures

Figure 1	San Fernando Wastewater Catchment Area .....	E-2
Figure 2	Existing Sewered Areas (shaded) and WWTPs in San Fernando Project Area .....	E-3
Figure 3	Existing and Proposed WWTP Site .....	E-5
Figure 4	WWTP Liquid Stream Flow Schematic .....	E-7
Figure 5	WWTP Solid Stream Flow Schematic .....	E-8
Figure 6	Subcatchments of the San Fernando Wastewater Project .....	E-9
Figure 7	Proposed San Fernando Wastewater Collection System .....	E-11
Figure 8	Phase I Construction Contract: WWTP and Collection System .....	E-13
Figure 1-1	San Fernando Wastewater Project Area .....	1-3
Figure 3-1	Project Boundaries, Roads and Rivers .....	3-3
Figure 3-2	Map of San Fernando and Environs Showing Land Use (White, 2009) .....	3-5
Figure 3-3	Existing Lift Stations and WWTPs, with current sewerage areas displayed .....	3-8
Figure 3-4	Section of Trunk Sewer Along the Sea Wall Showing Possible Points of Inflow at Pipe Joints .....	3-9
Figure 3-5	Section of Trunk Sewer along Vistabella River Showing Open Joint .....	3-9
Figure 3-6	Location of Existing San Fernando WWTP .....	3-17
Figure 3-7	WWTP Liquids Flow .....	3-19
Figure 3-8	WWTP Solids Flow Schematic .....	3-20
Figure 3-9	WWTP Process Flow Diagram .....	3-21
Figure 3-10	WWTP Site Plan .....	3-22
Figure 3-11	Water Balance Flow Schematic for San Fernando WWTP .....	3-23
Figure 3-12	Dry Pit Submersible Pumps (Chicago Pump) .....	3-24



Figure 3-13 Package Septage Receiving Unit (Courtesy of JWC Environmental) ..... 3-25

Figure 3-14 Band – Type Fine Screen (Courtesy of JWC Environmental)..... 3-26

Figure 3-15 Screenings Compactor (Courtesy of Huber Technology)..... 3-26

Figure 3-16 Recently Refurbished Primary Clarifiers at San Fernando WWTP..... 3-28

Figure 3-17 Fine Bubble Aeration Bioreactor ..... 3-29

Figure 3-18 Cloth Media Filter (Courtesy of Aqua-Aerobic Systems) ..... 3-30

Figure 3-19 Cloth Media Filtration Plant (Courtesy of Aqua-Aerobic Systems)..... 3-30

Figure 3-20 WAS, RAS, and Scum Decanter Schematic ..... 3-32

Figure 3-21 Stainless Steel DAF Tank ..... 3-33

Figure 3-22 Three Belt Filter Press (courtesy of Andritz)..... 3-34

Figure 3-23 San Fernando Proposed New Collection System..... 3-47

Figure 3-24 San Fernando Collection System Subcatchments..... 3-48

Figure 3-25 Marabella Subcatchment New Sewer Layout ..... 3-50

Figure 3-26 Tarouba-Cocoyea Subcatchment New Sewer Layout ..... 3-51

Figure 3-27 Cocoyea South Subcatchment New Sewer Layout..... 3-52

Figure 3-28 Pleasantville-Corinth Subcatchment New Sewer Layout ..... 3-53

Figure 3-29 Vistabella-Gulf Subcatchment New Sewer Layout ..... 3-54

Figure 3-30 San Fernando South Subcatchment New Sewer Layout..... 3-55

Figure 3-31 Ste. Madeline Subcatchment New Sewer Layout..... 3-56

Figure 3-32 Bel Air-Gulf View Subcatchment New Sewer Layout..... 3-57

Figure 3-33 Green Acres Subcatchment New Sewer Layout ..... 3-58

Figure 3-34 Duncan Village Subcatchment New Sewer Layout..... 3-59

Figure 3-35 Union Hall Subcatchment New Sewer Layout ..... 3-60

Figure 3-36 Retrench Golconda Subcatchment New Sewer Layout ..... 3-61

Figure 3-37 La Romain North Subcatchment New Sewer Layout..... 3-62

Figure 3-38 La Romain Central Subcatchment New Sewer Layout ..... 3-63

Figure 3-39 La Romain South Subcatchment New Sewer Layout..... 3-64

Figure 3-40 Palmiste South Subcatchment New Sewer Layout..... 3-65

Figure 3-41 Picton Subcatchment New Sewer Layout..... 3-66

Figure 3-42 Construction Phasing, Phase I..... 3-70

Figure 3-43 Trunk Sewer and Shaft Locations..... 3-74

Figure 4-1 Flow Schematic of Option L1 ..... 4-5

Figure 4-2 Cloth Media Filter (Courtesy of Aqua-Aerobic Systems) ..... 4-6

Figure 4-3 Conceptual Site Layout of Option L1 ..... 4-6

Figure 4-4 Flow Schematic of Option L2..... 4-8

Figure 4-5 Conceptual Site Layout of Option L2..... 4-8

Figure 4-6 Flow Schematic of Option L3..... 4-10

Figure 4-7 Conceptual Site Layout of Option L3..... 4-10

Figure 4-8 Flow Schematic of Option L4..... 4-11

Figure 4-9 Conceptual Site Layout of Option L4..... 4-12

Figure 4-10 Flow Schematic of Option L5..... 4-13

Figure 4-11 Conceptual Site Layout of Option L5..... 4-13

Figure 4-12 Schematic of Option S1 ..... 4-18

Figure 4-13 Schematic of Option S2 ..... 4-19

Figure 4-14 Schematic of Option S3 ..... 4-20



Figure 4-15 Schematic of Option S4 ..... 4-21

Figure 4-16 Schematic of Option S5 ..... 4-22

Figure 5-1 Mean Monthly Wind Speeds (Weather Underground Inc.)..... 5-3

Figure 5-2 Mean Monthly Temperatures (Weather Underground Inc.) ..... 5-4

Figure 5-3 Mean Monthly Humidity (Weather Underground Inc.)..... 5-5

Figure 5-4 Mean Monthly Precipitation (Meteorological Services Division)..... 5-6

Figure 5-5 Isohyetal Map of Trinidad (Genivar, 2009)..... 5-7

Figure 5-6 Hurricane Tracks for Trinidad during the period 1851 to 2008 (Storm CARIB Caribbean Hurricane Network) ..... 5-9

Figure 5-7 Recent Seismic Activity in Trinidad on 21 April 2010 ..... 5-10

Figure 5-8 Earthquake Epicenters with Magnitudes Greater Than 5 from 1900 to 2005 ..... 5-11

Figure 5-9 Seismic Hazard Map of Trinidad..... 5-12

Figure 5-10 Soils Map of Trinidad, 1971 (Lands and Surveys Division) ..... 5-15

Figure 5-11 Sites of Soil Investigation within San Fernando Collection System ..... 5-16

Figure 5-12 Physiographic Regions of Trinidad (Donovan, 1994) ..... 5-19

Figure 5-13 Geological Map of Project Area (Saunders, 1997)..... 5-20

Figure 5-14 Drainage Features within the San Fernando Wastewater Catchment..... 5-22

Figure 5-15 Hydrometric Areas and Watersheds of Trinidad (Genivar, 2009)..... 5-23

Figure 5-16 Sampling Locations for Water Quality Testing ..... 5-26

Figure 5-17 Guaracara River Upstream Sampling Location ..... 5-32

Figure 5-18 Guaracara River Downstream Sampling Location ..... 5-32

Figure 5-19 Marabella River Upstream Sampling Location ..... 5-33

Figure 5-20 Marabella River Gulf Sampling Location..... 5-33

Figure 5-21 Vistabella River Upstream Sampling Location ..... 5-34

Figure 5-22 Vistabella River Downstream Sample Location..... 5-34

Figure 5-23 Ciperio River Upstream Sampling Location..... 5-35

Figure 5-24 Ciperio River Downstream Sampling Location..... 5-35

Figure 5-25 Ally's Creek Sampling Location ..... 5-36

Figure 5-26 Land Use in San Fernando Wastewater Catchment..... 5-40

Figure 5-27 Dates and Locations of Sites Visited for Terrestrial Fauna Study ..... 5-43

Figure 5-28 Ciperio River in Concrete Channel at Grid Reference 668521mE, 1134820mN ..... 5-44

Figure 5-29 Ciperio River at Grid Reference 670148mE, 1134594mN..... 5-44

Figure 5-30 Mangrove Woodland North of the Guaracara River Accessed via Point-a-Pierre ..... 5-45

Figure 5-31 Mangrove Woodland South of Guaracara River Mouth..... 5-45

Figure 5-32 Mudflats at the Mouth of the Ciperio River. Viewed from Bel-Air 666301mE, 1134246mN ..... 5-46

Figure 5-33 Mudflats at the Mouth of the Vistabella River. Viewed from Boatyard at 668298mE, 1137924mN ..... 5-46

Figure 5-34 Sampling Locations for Aquatic Survey..... 5-48

Figure 5-35 Air and Noise Monitoring Stations in San Fernando Wastewater Catchment Area..... 5-79

Figure 6-1 Land Use in San Fernando Wastewater Catchment based on Human Activity..... 6-5

Figure 6-2 Archaeological Sites in San Fernando Wastewater Catchment..... 6-8

Figure 6-3 Status of Employment in San Fernando City Corporation (Central Statistical Office, 2002) ..... 6-10

Figure 6-4 General Occupational Groups (Central Statistical Office, 2002) ..... 6-11





Figure 6-5 Residents Employed within Industry Sector (Central Statistical Office, 2002) .....6-11

Figure 6-6 Recreational Places in San Fernando Wastewater Catchment.....6-14

Figure 6-7 Number of Persons in Household, Social Survey 2010.....6-16

Figure 6-8 Age-Sex Distribution in San Fernando City Corporation (Central Statistical Office, 2002) 6-17

Figure 6-9 Religious Composition of San Fernando Municipality (Central Statistical Office, 2002) 6-18

Figure 6-10 Ethnic Composition of San Fernando City (Central Statistical Office, 2002).....6-19

Figure 6-11 Ethnicity of Respondents of Social Survey 2010 .....6-19

Figure 6-12 Status of Schooling for the period 2000 (Central Statistical Office, 2002).....6-20

Figure 6-13 Highest Educational Attainment (Central Statistical Office, 2002).....6-21

Figure 6-14 Highest Exam Level Passed (Central Statistical Office, 2002) .....6-21

Figure 6-15 Housing Material in Surveyed Areas.....6-22

Figure 6-16 Domestic Water Supply in San Fernando Wastewater Catchment.....6-23

Figure 6-17 Domestic Water Supply in the City of San Fernando (Central Statistical Office, 2002) 6-23

Figure 6-18 Type of Facilities for Wastewater Disposal among Residents of the San Fernando Wastewater Catchment .....6-24

Figure 6-19 Number of Toilets in Household and Type of Disposal Systems for Wastewater in Dwellings within the San Fernando Wastewater Catchment .....6-24

Figure 6-20 Type of Toilet Facilities in the City of San Fernando (Central Statistical Office, 2002) 6-25

Figure 6-21 Type of Energy Source Connection in Project Area.....6-26

Figure 6-22 Household Energy Sources in San Fernando City (Central Statistical Office, 2002) .....6-26

Figure 6-23 Residents in the City of San Fernando with Telephones (Central Statistical Office, 2002) 6-27

Figure 6-24 Residents in the City of San Fernando with Internet (Central Statistical Office, 2002)..6-28

Figure 6-25 Type of School Persons Enrolled in the City of San Fernando (Central Statistical Office, 2002).....6-30

Figure 6-26 Length of Awareness of San Fernando Wastewater Project.....6-33

Figure 6-27 Traffic Sampling Locations .....6-37

Figure 8-1 Area of Traffic Influence of Entrance to San Fernando WWTP .....8-18

## List of Tables

Table 1 San Fernando WWTP Effluent Criteria..... E-6

Table 2 Proposed Collection System Pipe Length by Subcatchment..... E-12

Table 3 Fecal Coliform Data (CFU/100ml) from River Quality Sampling..... E-15

Table 4 Land Use Categories in San Fernando Wastewater Catchment ..... E-16

Table 5 Fauna Survey Species Observed..... E-16

Table 6 Project-Environment Interaction with Affected Environment ..... E-17

Table 7 Summary of Impacts Pre-and Post Mitigation ..... E-18

Table 1-1 Team Member Details for EIA Study ..... 1-5

Table 2-1 Water Pollutant Parameters for Source Registration (First Schedule of WPR).....2-4

Table 2-2 Permissible Levels of Water Pollutant Parameters in Different Receiving Environments, WPR 2001 (as amended).....2-5

Table 2-3 Prescribed Standards According to the First Schedule, NPCR.....2-7



Table 2-4 Air Pollutant Concentration at WWTP .....	2-13
Table 2-5 Effluent Guidelines for WWTP.....	2-13
Table 2-6 Maximum Permissible Levels for Liquid Effluent from Domestic Wastewater Treatment Plants (TTS 417:1993) .....	2-18
Table 2-7 Permissible Limits for Effluent Discharge from Industrial Processes (TTS 547:1998) .....	2-19
Table 2-8 List of Multinational Agreements, Treaties and Conventions Ratified by Trinidad and Tobago.....	2-24
Table 3-1 Summary of Population Projections.....	3-6
Table 3-2 Existing Lift Stations and WWTPs in San Fernando Area .....	3-6
Table 3-3 Raw Wastewater Concentrations at the Existing San Fernando WWTP (2009) .....	3-11
Table 3-4 Sources of Septage for the Existing San Fernando WWTP .....	3-11
Table 3-5 Septage Volumes in 2008.....	3-12
Table 3-6 Typical Septage Concentrations.....	3-13
Table 3-7 Raw Wastewater Concentrations at Harmony Hall (2009).....	3-13
Table 3-8 Summary of Project Design Flows.....	3-14
Table 3-9 Average Design Loads for San Fernando WWTP .....	3-14
Table 3-10 San Fernando WWTP Effluent Criteria .....	3-16
Table 3-11 San Fernando Wastewater Treatment Plant Design Data .....	3-36
Table 3-12 New Collection System Pipe Length by Subcatchment.....	3-49
Table 3-13 Lift Station Information .....	3-67
Table 3-14 Lift Station Location Descriptions .....	3-68
Table 3-15 Phase I of Subcatchment Construction Information .....	3-69
Table 3-16 Additional Phases of Subcatchment Construction Information .....	3-71
Table 4-1 Advantages and Disadvantages of Option L1 .....	4-7
Table 4-2 Advantages and Disadvantages of Option L2 .....	4-9
Table 4-3 Advantages and Disadvantages of Option L3 .....	4-11
Table 4-4 Advantages and Disadvantages of Option L4 .....	4-12
Table 4-5 Advantages and Disadvantages of Option L5 .....	4-14
Table 4-6 Evaluation Criteria .....	4-14
Table 4-7 Rating Table of Options .....	4-15
Table 4-8 Conceptual Cost Comparison of Surface Aeration and Fine Bubble Aeration.....	4-17
Table 4-9 Advantages and Disadvantages of Option S1 .....	4-19
Table 4-10 Advantages and Disadvantages of Option S2 .....	4-20
Table 4-11 Advantages and Disadvantages of Option S3 .....	4-21
Table 4-12 Advantages and Disadvantages of Option S4 .....	4-22
Table 4-13 Advantages and Disadvantages of Option S5 .....	4-23
Table 4-14 Rating Table of Options .....	4-23
Table 5-1 List of Hurricanes and Tropical Storms Affecting Trinidad .....	5-9
Table 5-2 Grain Composition of Soil Units.....	5-14
Table 5-3 List of Borehole Sites for San Fernando Wastewater Collection System.....	5-17
Table 5-4 Geological Formation and Sedimentology.....	5-20
Table 5-5 River Flow Data at Ciperó River, Station Number 10803 (Water Resources Agency, 2010).....	5-24
Table 5-6 Results from Analysis of Water Samples from Guaracara River.....	5-27
Table 5-7 Results from Analysis of Water Samples from Marabella River.....	5-28



Table 5-8 Results from Analysis of Water Samples from Vistabella River ..... 5-29

Table 5-9 Results from Analysis of Water Samples from Cipero River ..... 5-30

Table 5-10 Results from Analysis of Water Samples from Ally's Creek ..... 5-31

Table 5-11 Water Quality Parameters That Decreased in Quality within the Catchment ..... 5-36

Table 5-12 Land Use Categories and Area in San Fernando Wastewater Catchment ..... 5-41

Table 5-13 Observed Habitats and Flora Species Observed ..... 5-42

Table 5-14 Locations Sampled for Aquatic Fauna Study ..... 5-47

Table 5-15 Amphibians and Reptiles Which May be Expected Within San Fernando and Environs 5-50

Table 5-16 Birds of Trinidad Likely to be Found Within San Fernando and Environs and the Habitats  
in Which They are Likely to be Found ..... 5-52

Table 5-17 Mammals of Trinidad Which May be Expected Within San Fernando and Environs..... 5-62

Table 5-18 Historical Records of Aquatic Species Found Within San Fernando and Environs ..... 5-63

Table 5-19 Butterfly Species Common or Abundant and Widespread in Trinidad and are Likely to  
Occur in the Greater San Fernando Area. .... 5-65

Table 5-20 Butterflies Observed Within San Fernando and Environs, October 2009 ..... 5-67

Table 5-21 Description of Fish Species Captured per Sample Station..... 5-68

Table 5-22 Bird Species Observed Within San Fernando and Environs, October 2009 ..... 5-70

Table 5-23 Sound Level Monitoring Results..... 5-80

Table 5-24 Average Leq and Lpeak Measurements for Noise Sampling..... 5-81

Table 5-25 TSP and PM2.5 Air Quality Results in San Fernando Wastewater Catchment ..... 5-82

Table 6-1 Subcatchments within Administrative Areas ..... 6-2

Table 6-2 New and Proposed Housing Developments in the San Fernando Wastewater Catchment... 6-6

Table 6-3 Classification of Archaeological Sites ..... 6-7

Table 6-4 Businesses in San Fernando Wastewater Catchment (Central Statistical Office, 2002) ..... 6-9

Table 6-5 Population Count by Regional Corporation ..... 6-15

Table 6-6 2009 Socio-Economic Status for San Fernando Project Area..... 6-28

Table 6-7 Health Centres in Project Area..... 6-29

Table 6-8 Preferred Price for Sewer Service (Quarterly Rate)..... 6-35

Table 6-9 Traffic Counting Results, March 23-25, 2010 ..... 6-38

Table 7-1 Schedule for Public Consultations and Stakeholder Meeting ..... 7-2

Table 7-2 Introductory Meetings held with Relevant Agencies ..... 7-3

Table 7-3 Questions and Answers from September 30, 2009 Meeting. .... 7-4

Table 7-4 Key Questions and Answers from January 26, 2010 Meeting ..... 7-5

Table 7-5 Key Questions and Answers from April 13, 2010 Meeting ..... 7-7

Table 8-1 Explanation of Terms Used in Impact Assessment..... 8-2

Table 8-2 Project-Environment Interaction with Affected Environment ..... 8-4

Table 8-3 Weekly Anticipated Traffic at San Fernando WWTP Site During Operation ..... 8-7

Table 8-4 Summary of Project Impacts and Mitigation Measures ..... 8-28

Table 8-5 Summary of Accident and Malfunction Impacts and Mitigation Measures ..... 8-39

Table 9-1 Monitoring Plan – Construction Phase..... 9-7

Table 9-2 Monitoring Plan – Operation Phase ..... 9-9



## Appendices

- Appendix A. Application and Terms of Reference for Certificate of Environmental Clearance
- Appendix B. Legislative and Regulatory Framework
- Appendix C. Project Description
- Appendix D. Biophysical Baseline Data
- Appendix E. Socio-Economic Baseline Data
- Appendix F. Key Stakeholder and Public Consultations
- Appendix G. Impact Assessment and Mitigation Measures
- Appendix H. Environmental Monitoring and Management



# 1. Introduction

## 1.1 Overview

The Water and Sewerage Authority (WASA) of the Ministry of Public Utilities (MOPU) applied to the Environmental Management Authority (EMA) in August, 2006 for a Certificate of Environmental Clearance (CEC) for the establishment of a regional wastewater plant, inclusive of works, laying of sewer mains, and decommissioning of existing wastewater facilities in the city of San Fernando and environs. The project area is roughly bounded by the Guaracara River in the north, Solomon Hochoy Highway in the east inclusive of Ste. Madeline, developments inside of the M2 Ring Road in the south, and Gulf of Paria in the west.

The EMA adjudged the project to have significant environmental and social impacts and notified WASA that the CEC application could only be entertained after completion of an Environmental Impact Assessment (EIA) study conducted against specific terms of reference. Final Terms of Reference (TOR) were provided to WASA by the EMA on 21<sup>st</sup> November 2006 (Ref: CEC1597/2006) for the conduct of an EIA study (**Appendix A**).

## 1.2 Project Background

The city of San Fernando is the second largest urban centre in Trinidad. It is the commercial hub of south Trinidad and has been steadily expanding with the growth of the oil and gas sector and downstream activities in south Trinidad. The city of San Fernando's current population is approximately 55,400. The city is serviced by a wastewater collection, treatment and disposal system built in the 1960's and owned and operated by WASA. The collection system has approximately 72 km of piping, and services approximately 25,000, which is less than half of the city's population. The wastewater treatment plant, located adjacent to the Ciperu River at the west end of Riverside Drive, was originally designed to treat 20 ML/d. A septage receiving station was constructed at the San Fernando plant in the 1980's.

The wastewater system has functioned adequately for a number of years, but has passed its useful design life and is in need of major rehabilitation and expansion to meet the current and future needs of the city and surrounding areas. Field studies have revealed that sections of the existing collection system are in need of replacement as some visible sections of trunk sewer have broken open and fallen into drains and rivers, allowing untreated wastewater into the waterways.

The areas outside of the existing San Fernando collection system have experienced significant development over the past several years. The estimated population of the surrounding areas outside the city limits is approximately 47,600. Numerous private and government housing, commercial and institutional developments have emerged along with separate wastewater collection systems, pump stations and packaged wastewater treatment plants (WWTPs). Most of the outlying treatment facilities are not owned and maintained by WASA. These areas include Harmony Hall, Tarouba, Pleasantville, Palmiste, and Gulf View. In addition, approximately 70% of developed areas surrounding San Fernando are not sewered. They are serviced by on-lot systems including septic tanks, soak-aways, and pit latrines. The conditions of these existing systems vary; however, the majority of the systems are not



functioning or only partially functioning, resulting in untreated or partially treated wastewater entering waterways.

### 1.3 San Fernando Wastewater Treatment Plant and Collection System

WASA intends to improve the wastewater sector in the city of San Fernando and environs by expanding the sewered service area and improving the level of wastewater treatment for existing and new customers in the rapidly developing area. The end result of the project will be an integrated wastewater system that provides a cost-effective and sustainable wastewater collection and treatment within the project boundaries. The main benefits of the project include:

- Reduction in public health risk associated with untreated wastewater discharges into drains, rivers and other water courses.
- Improvement of water quality in the Guaracara, Marabella, Vistabella and Cipero Rivers that currently receive wastewater discharges.
- Overall improvement to the surrounding environment through the proper collection, treatment and disposal of wastewater that is presently adversely affecting the environment.
- Potential for production of up to 45 ML/d of reclaimed water that is suitable for irrigation and other non-potable uses in the area.
- Overall improvement in the quality of life for the citizens of San Fernando and environs.

The San Fernando Wastewater project involves one integrated and centralized collection system and WWTP in the San Fernando and environs area. The project boundary as well as major roads and rivers are shown in yellow on Figure 1-1. The collection system design includes installation of new trunk sewers for conveying wastewater to the new WWTP, new local sewers to capture flow from properties that do not currently have sewer service, and connection of new and existing sewers into one integrated collection system. The new WWTP will replace the existing San Fernando WWTP, Harmony Hall WWTP, and several smaller plants previously installed by developers. The new WWTP will be located on the site of the existing San Fernando WWTP, at the western end of Riverside Drive, north of the Cipero River.

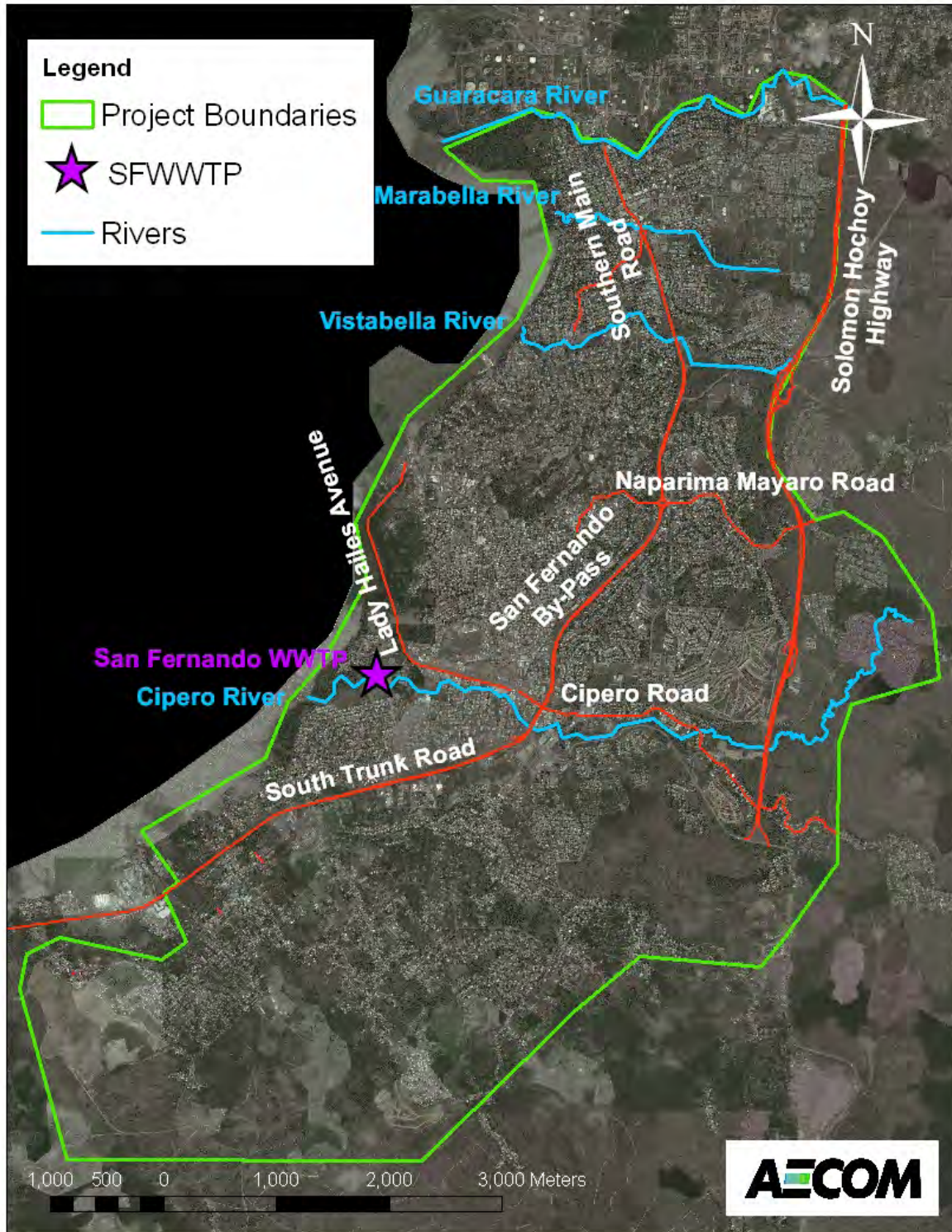


Figure 1-1 San Fernando Wastewater Project Area



With the implementation of the project, WASA will become the sole responsible Authority for wastewater treatment and disposal in the regional Catchment, and will be able to effectively monitor, regulate and control effluent discharged to the environment.

## 1.4 Scope of the EIA

The TOR for the conduct of this EIA study was provided to WASA by the EMA. A copy of the TOR is provided in **Appendix A**.

The scope of works for the project includes the following tasks as identified in the TOR:

- Conduct a literature review (including legislative requirements) of existing information in the public domain related to the proposed establishment of the wastewater treatment plants and associated works, as well as the areas adjacent to the proposed development area.
- Identify data gaps existing in the public domain that are pertinent to describing the biophysical and social environmental baseline that exists within the project affected area.
- Perform field surveys to collect social and environmental data to fill data gaps and establish baseline conditions.
- Determine potential environmental and social impacts of the proposed activity.
- Evaluate various project alternatives and justify the preferred alternative on the basis of technical, financial, environmental, social and planning requirements.
- Conduct consultations with all relevant stakeholders and members of the general public.
- Develop mitigation measures and strategies to manage any negative residual impacts of the project or maximize beneficial elements of the project.
- Develop a management plan for all phases of the project life.
- Develop a monitoring plan for the different phases of the project.

## 1.5 Report Structure

The EIA studies the nature and extent of environmental and social impacts that will arise from the construction and operation of one integrated wastewater collection system and treatment plant in the San Fernando area.

The EIA Report provides a set of recommendations throughout the assessment process, which have been included in the detailed design of the project, and are recommended for later phases of work to minimize any adverse impacts on the development and to maximize the practical benefits for the environment. A baseline assessment of the various environmental and social parameters, which resulted in the recommendations, is also presented.

The EIA Report is presented in the following format:

- |           |  |
|-----------|--|
| Section 2 | Legislative, Regulatory and Policy Framework |
| Section 3 | Project Description                          |
| Section 4 | Alternatives to Project                      |





Section 5	Biophysical Environmental Setting
Section 6	Social Environmental Conditions
Section 7	Key Stakeholder and Public Consultation
Section 8	Impact Analysis and Mitigation Measures
Section 9	Environmental Management and Monitoring Plan
Section 10	Bibliography

## 1.6 List of Report Preparers and EIA Project Team

The contract for the conduct of an EIA study for the proposed San Fernando Wastewater Project was established between WASA and AECOM. AECOM was also retained to conduct the detailed design of the WWTP and collection system. This work began in 2009.

Qualified personnel with expertise and experience contributed to the findings of this EIA. Each team member possesses a specific area of expertise in one or more of the disciplines needed for the completion of the EIA for this project.

The table below lists each team member and their years of experience within the respective fields.

**Table 1-1 Team Member Details for EIA Study**

Name of Preparer	Organization	Years of Experience
Jim Marx	AECOM	>30
Matt McTaggart	AECOM	>25
Stephen Biswanger	AECOM	>15
Alison Weiss	AECOM	>6
Natalie Wilson	AECOM	>4
Sara-Jade Govia	AECOM	>2
Kimlin Austin	WASA	>15
Graham White	Self employed	>30
Paul Comeau	Self-employed	>30
Elka Bachan	Environmental Sciences Limited	>6
Nadeera Supersad	Environmental Sciences Limited	>4
Erin Mangal	Environmental Sciences Limited	>8
Steffan Shageer	Environmental Sciences Limited	>4
Erna Kirk	Market Facts & Opinions	>16
Lucrecia Birch	Market Facts & Opinions	>10
Kimberly Philip	Market Facts & Opinions	>4



## 2. Legislative, Regulatory, and Policy Framework

### 2.1 Introduction

This section introduces the legislative, regulatory and policy framework of Trinidad and Tobago pertaining to the San Fernando Wastewater Project. The project will be subjected to the following as described in the report:

- Acts of Parliament
- Rules of Trinidad and Tobago
- Pertinent guidelines of the Water and Sewerage Authority
- Applicable Standards of other legislative authorities
- National policies
- Regional and international treaties ratified by the Government of Trinidad and Tobago

### 2.2 Environmental Management Act

The Environmental Management Act was passed in 2000 in the Trinidad and Tobago Parliament and was meant to repeal and re-enact the previous Environmental Management Act that was passed in 1995. The basic notion of the Act is to regulate the conservation and management of the environment. Specific objectives of the Act are:

- Promotion of the environment
- Integration of the environment in decision-making
- Establishment of integrated environmental management systems
- Development and integration of laws and policies
- Enhancement of the legal and regulatory framework for environmental management

The Act stipulated the establishment of the Environmental Management Authority (EMA) as the corporate entity that would be responsible for mandating specifics of this Act. The Environmental Management Act also specified the formation of the Environmental Commission, which is charged with enforcing the regulations and policies associated with the Act.

#### 2.2.1 Environmental Management Authority

The EMA was formed in 1995 when the initial Environmental Management Act was formulated. When this Act was revoked and modified in 2000, some of the roles and functions of the EMA changed. The responsibilities of the organization are as follows:

- Make recommendations for a National Environmental Policy
- Formulate and implement policies for environmental management
- Co-ordinate environmental functions
- Make recommendations for rationalising government agencies with environmental functions
- Promote public awareness of the environment
- Formulate and implement environmental standards
- Monitor compliance with environmental standards



- Take appropriate action to prevent and control pollution for environmental conservation
- Establish links to local, regional and international institutions
- Perform other prescribed functions
- Undertake any action pertinent to the functions of the Authority

As mandated in the Environmental Management Act, the EMA is charged with the responsibility of formulating rules for environmental management specifically in relation to sustainable development and pollution management in Trinidad and Tobago. Subsequently, the EMA has institutionalized the following legislation as one of the mechanisms to attaining integrated environmental management:

- Certificate of Environmental Clearance Rules
- Water Pollution Rules
- Noise Pollution Control Rules
- Draft Air Pollution Rules
- Environmentally Sensitive Areas Rules
- Environmentally Sensitive Species Rules
- Draft Waste Management Rules

Each regulation and the relevance to the San Fernando Wastewater project will be discussed in this section.

### 2.2.2 Certificate of Environmental Clearance Rules

The Certificate of Environmental Clearance (CEC) Rules was enacted in 2001 and amended both in 2007 and 2008. A document entitled the CEC (Designated Activities) Order was also formulated as part of the CEC Rules, 2001. This lists all the activities that may potentially require a CEC and therefore an application would be required prior to construction. The San Fernando Wastewater Project falls under the category of Activity 42 defined as:

- Establishment of wastewater or sewage treatment facilities: The establishment, modification, expansion, decommissioning or abandonment (inclusive of associated works) of a wastewater or sewage treatment facility.

The CEC Rules, 2001 explains the procedure for submitting a CEC application by the company or agent responsible for the specific development. The CEC application form generally requests details on the nature and purpose of the activity, description of the processes involved, specifics on waste handling and storage of hazardous substances and an explanation of the natural environment at the proposed site.

According to the CEC Rules the application must be submitted to the Town and Country Planning Division (TCPD) in the respective location of the site. This is to ensure coordination among government entities and that the development fulfils the requirements of the Town and Country Planning Act as discussed in Section 2.12.2. The application is passed onto the EMA for processing.

The EMA then reviews the application and conducts a field visit to the proposed site with the applicant if necessary. Within ten working days of receipt of the application the EMA submits official notification of the decision made for granting the CEC, which may be:



- No CEC required since the development does not fall into any of the categories as listed in the CEC (Designated Activities) Order.
- A request for more information.
- A CEC is required but an EIA does not have to be conducted.
- An EIA is required for the CEC to be granted and it must fulfil the Terms of Reference (TOR) set by the EMA.
- A decision on a claim for confidentiality where it was requested by the applicant.

Where an EIA is required, members of the public are allowed to examine the contents of the final EIA report and submit comments to the EMA. In some situations other relevant government and corporate entities assist the EMA in the evaluation of the EIA. A decision is then made by the EMA on whether a CEC would be granted or refused.

The CEC application for the San Fernando Wastewater Project was submitted by WASA to follow the regulations stipulated in the CEC Rules, 2001. The EMA concluded that this project requires a CEC and an EIA is necessary for making a decision on the application. The TOR was developed by the EMA as discussed in Section 1.

### 2.2.3 Water Pollution Rules

The Water Pollution Rules (WPR) were enacted in 2001 and amended in 2006. The WPR stipulated the compilation of a Register of Water Pollutants that lists all the facilities that discharge into the environment and the characteristics of the water pollutant discharged.

According to the WPR a company or individual that releases a substance that may be hazardous to human health and the environment must submit a source application to the EMA prior to discharge of the substance. If the water pollutant is discharged into the environment outside of the permissible levels as dictated by the WPR a permit is required.

The application procedure for source registration includes a description of the process producing the water pollutant, volume and rate of release of the substance, effluent quality, releasing environment characteristics and details of any water pollution control programme.

The WPR outlines the parameters for water pollutants that are to be registered by the emitter. This is the First Schedule of the WPR as displayed in Table 2-1.

**Table 2-1 Water Pollutant Parameters for Source Registration (First Schedule of WPR)**

Parameter	Quantity at Which Substance is Defined a Pollutant
Temperature	Max. variation of 3°C from ambient
pH	<6 or >9
Dissolved Oxygen	<4
5-day Biological Oxygen Demand	>10
Chemical Oxygen Demand	>60
Total Suspended Solids	>15
Total Oil and Grease	>10
Ammoniacal Nitrogen	>0.01
Total Phosphorus	>0.1
Sulphide	>0.2
Chloride	>250
Total Residual Chlorine	0.2
Dissolved Hexavalent Chromium	>0.01
Total Chromium	>0.1
Dissolved Iron	>1
Total Petroleum Hydrocarbons	No increase above ambient
Total Nickel	>0.5
Total Copper	>0.01
Total Zinc	>0.1
Total Arsenic	>0.01
Total Cadmium	>0.01
Total Mercury	>0.005
Total Lead	>0.05
Total Cyanide	>0.01
Phenol	>0.1
Radioactivity	No increase above ambient
Toxicity	No acute toxic effects
Faecal Coliform	>100
Solid Waste	No solid debris

Note: all units are in milligrams per litre (mg/L), except for temperature (°C), pH (pH units), Faecal Coliforms (counts per 100 ml), radioactivity (Bq/L), and toxicity (toxic units).



The Second Schedule of the WPR outlines the permissible levels for water pollutants that require a permit for discharge. The parameters are defined for different receiving environments. These are categorized as follows:

- Inland Surface Water – rivers, creeks, tidal waters, estuaries, swamps, streams, lakes, impounding reservoirs, area which waters flowed but have evaporated in dry conditions.
- Coastal Nearshore – marine environment 3 nautical miles or less from the high water mark.
- Marine Offshore – marine environment seaward of the coastal nearshore zone.
- Environmentally Sensitive Area – defined in Section 2.2.6.
- Groundwater – water below the earth’s surface.

The effluent of the new San Fernando WWTP would be discharged into the Cipro River, which is categorised as “Inland Surface Water”. The effluent quality would need to meet the criteria represented in Table 2-2 under Inland Surface Water.

**Table 2-2 Permissible Levels of Water Pollutant Parameters in Different Receiving Environments, WPR 2001 (as amended)**

Water Pollutant Parameter	Receiving Environment			
	Inland Surface Water	Coastal Nearshore	Marine Offshore	ESA and/or Groundwater
Temperature	35	40	45	No increase above ambient
Dissolved Oxygen	>4	>4	>4	>4
pH	6-9	6-9	6-9	6-9
5-day Biological Oxygen Demand	30	50	100	10
Chemical Oxygen Demand	250	250	250	60
Total Suspended Solids	50	150	200	15
Total Oil and Grease	10	15	100	No release
Ammoniacal Nitrogen	10	10	10	0.1
Total Phosphorus	5	5	5	0.1
Sulphide	1	1	1	0.2
Chloride	250	No increase above ambient	No increase above ambient	No increase above ambient
Total Residual Chlorine	1	1	2	0.2
Dissolved Hexavalent Chromium	0.1	0.1	0.1	0.01
Total Chromium	0.5	0.5	0.5	0.1



**Table 2-2 Permissible Levels of Water Pollutant Parameters in Different Receiving Environments, WPR 2001 (as amended) (continued)**

Water Pollutant Parameter	Receiving Environment			
	Inland Surface Water	Coastal Nearshore	Marine Offshore	ESA and/or Groundwater
Dissolved Iron	3.5	3.5	3.5	1
Total Petroleum Hydrocarbons	25	40	80	No release
Total Nickel	0.5	0.5	0.5	0.5
Total Copper	0.5	0.5	0.5	0.01
Total Zinc	2	2	2	0.1
Total Arsenic	0.1	0.1	0.1	0.01
Total Cadmium	0.1	0.1	0.1	0.01
Total Mercury	0.01	0.01	0.01	0.005
Total Lead	0.1	0.1	0.1	0.05
Total Cyanide	0.1	0.1	0.1	0.01
Phenol	0.5	0.5	0.5	0.1
Radioactivity	No increase above ambient	No increase above ambient	No increase above ambient	No increase above ambient
Toxicity	No acute toxic effects	No acute toxic effects	No acute toxic effects	No acute toxic effects
Faecal Coliforms	400	400	400	100
Solid Waste	No solid debris	No solid debris	No solid debris	No solid debris

Note: all units are in milligrams per litre (mg/L), except for temperature (°C), pH (pH units), Faecal Coliforms (counts per 100 ml), radioactivity (Bq/L), and toxicity (toxic units).

ESA: Environmentally Sensitive Area

### 2.2.4 Noise Pollution Control Rules

The Noise Pollution Control Rules (NPCR) was formulated in 2001 by the EMA to regulate noise pollution in Trinidad and Tobago. The NPCR specifies the permissible sound levels for different environments. According to the rules, a person or company that intends to conduct an activity or event that will emit sound above the permissible level must submit an application for a noise variation.



This application must be completed four weeks before the event and a notice must be published in a national newspaper. A similar procedure applies for a noise variation for a facility; however, the application must be submitted ten working days prior to commencement of operation of the facility.

The NPCR outlines the different noise zones based on the type of activity undertaken in the area. These are defined as follows:

- Zone I – Industrial Areas: an area approved for industry by a governmental entity.
- Zone II – Environmentally Sensitive Areas: defined in Section 2.2.6.
- Zone III – General Areas: all other areas except industrial and environmentally sensitive areas.

The permissible sound levels for each zone are defined in the First Schedule of the NPCR. The San Fernando WWTP is located within an Industrial Zone according to the Town and Country Planning Division. The permissible sound pressure levels according to the First Schedule are presented in Table 2-3.

**Table 2-3 Prescribed Standards According to the First Schedule, NPCR**

Zone	Time of Day	Sound Pressure Level
I	Anytime	Equivalent continuous sound pressure level of 75 dBA. Instantaneous unweighted peak sound pressure level of 130 dB. No sounds emitted should exceed 60 dBA.
II	Day-time	Equivalent continuous sound pressure level of 3 dBA, above background. Instantaneous unweighted peak sound pressure level of 120 dB.
	Night-time	Equivalent continuous sound pressure level of 3 dBA above background. Instantaneous unweighted peak sound pressure level of 115 dB.
	Anytime	No sounds emitted should exceed 60 dBA.
III	Day-time	Equivalent continuous sound pressure level of 5 dBA above background; not to exceed 80 dBA. Instantaneous unweighted peak sound pressure level of 120 dB.
	Night-time	Equivalent continuous sound pressure level of 5 dBA above background; not to exceed 65 dBA. Instantaneous unweighted peak sound pressure level of 115 dB.

The Second and Third Schedule of the regulation defines how sound pressure levels should be recorded and reported (**Appendix B.1**). The method by which the meter should be calibrated is also described in the NPCR. Generally, sound is measured at the property line of the complainant or that of the sound emissions. In cases of a noise complaint, the sound at the property line of the activity is used to determine if the level is beyond the permissible limits.

Some activities are exempt from abiding by the standards of the NPCR pertinent to the San Fernando Wastewater Project are:

- Sound associated with the installation, repair or replacement of public utilities in a public place between the hours of 7:00 am and 11:00 pm of the same day.





- Construction activity when conducted on a construction site between the hours of 7:00 am and 7:00 pm of the same day.

The guidelines of the NPCR will be followed when constructing and operating the San Fernando WWTP and Collection System.

### 2.2.5 Draft Air Pollution Rules

The Draft Air Pollution Rules (APR) were formulated in 2005 and are yet to be enacted by the Government of Trinidad and Tobago. The APR outlines the procedure for registering a source emitter and obtaining a permit for releasing air pollutants. A source emitter is defined as a person or operator of a facility that releases an air pollutant into the atmosphere.

The activities that have potential to emit air pollutants are defined in the First Schedule of the APR. The operation of a wastewater treatment plant falls under Category 12, “Waste Handling”. The Activity is “Waste Treatment and Disposal” the APR describes the San Fernando WWTP under Description 4, “Treatment Works Emissions”.

According to the APR, an air pollutant is any substance released in excess of the permissible levels as listed in the Second and Third Schedule. The Second Schedule classifies the maximum levels for non-point sources where the exact location or stack is undefined (**Appendix B.2**). Vehicular emissions are not categorised as non-point sources according to the APR.

The Third Schedule of the APR presents the stack release limits of substances considered air pollutants. The design of the new San Fernando WWTP does not include any vertical pipe where emissions would be released therefore the regulations would not apply to this project.

### 2.2.6 Environmentally Sensitive Areas Rules

The Environmentally Sensitive Areas (ESA) Rules were formulated in 2001 as part of the mandate of the EMA to protect and conserve the natural resources and environment of Trinidad and Tobago. The purpose of the ESA Rules is to ensure that specific activities are not undertaken in defined areas. According to the rules, an ESA is characterised by the following criteria:

- The actual or prospective habitat of an Environmentally Sensitive Species (ESS), which is defined in Section 2.2.7.
- An area defined in any of the international conventions ratified by the government of Trinidad and Tobago. Mention is made of these agreements in Schedule I of the ESA Rules, including:
  - The Convention for the Protection of Development of Marine Environment of the Wider Caribbean Region (1986).
  - The Specially Protected Areas and Wildlife Protocol (1990).
  - The Convention on Wetlands (1993).
  - The United Nations Framework Convention on Climate Change (1994).
  - The United Nations Convention on Biological Diversity (1996).
- An area that falls into the category defined in the Guidelines listed in Schedule II of the ESA Rules.



- An area referred in any of the written laws of Trinidad and Tobago (**Appendix B.3**).

A legal notice must be advertised by the EMA before an area is declared an ESA. The notice will provide details on the precise location and boundaries of the ESA, the reasons for designation, specifics on the use and type of activities that can be carried out within the ESA and any mitigation measures that can be undertaken to restore the environment.

To date the Aripo Savannas, Nariva Swamp and Matura National Park have been designated as ESAs. None of these areas are within the boundaries of the San Fernando Wastewater Project.

### 2.2.7 Environmentally Sensitive Species Rules

The Environmental Management Act states that the EMA is also responsible for the protection of endangered species within Trinidad and Tobago. The Environmentally Sensitive Species (ESS) Rules were enacted in 2001 to legislate the protection of plant and animal species in their natural environment.

The following criteria guide the designation of an ESS:

- A species indigenous to Trinidad and Tobago.
- A species in danger of extinction.
- A species defined in any of the international conventions ratified by the government of Trinidad and Tobago. These agreements are listed in Schedule I of the ESS Rules, they include:
  - The Convention on International Trade in Endangered Species of Wild Fauna and Flora (1984).
  - The Specially Protected Areas and Wildlife Protocol (1990).
  - The Convention on Wetlands (1993).
  - The United Nations Convention on Biological Diversity (1996).
- An area that falls into the category defined in the Guidelines listed in Schedule II of the ESS Rules.
- An area referred in any of the written laws of Trinidad and Tobago.

Similar to the ESA Rules a legal notice must be provided by the EMA describing the species, natural habitat, reasons for the designation, limitations on the use of the species and mitigation measures for protecting the species and its habitat.

Included in the regulation are the activities that are prohibited when an ESS Notice is submitted. In terms of living plant species, the organism cannot be disturbed or destroyed by picking, collection, cutting, uprooting or possession of trade. With respect to living animal species, the organism cannot be hunted, traded or disturbed during the breeding, incubation, estivation or migratory phases. The ESS Rules exempt the captive breeding and propagation of the environmentally sensitive animal or plant species.

The Pawi (*Pipile pipile*), White-tailed Sabrewing Hummingbird (*Campylopterus ensipennis*) and West Indian Manatee (*Trichechus manatus*) have been named ESS by the EMA to date. The EMA is also



proposing that the Golden Tree Frog (*Phyllodytes auratus*) and the Ocelot (*Leopardus pardalis*) be designated as ESS.

The species mentioned above have not been found during the biophysical investigations of the San Fernando Wastewater Project area nor has it been historically recorded that these ESS inhabited any part of the project area. The legislation is therefore not applicable to this project but will still be carefully considered when undertaking construction and operation of the San Fernando WWTP and Collection System.

### 2.2.8 Draft Waste Management Rules

The Draft Waste Management Rules were drafted in 2008 by the EMA. The Environmental Management Act stipulates that the EMA is responsible for implementing a programme for management of waste and establishing appropriate guidelines for the handling and disposal of waste.

The rules refer to the following activities as a method by which waste management can be regulated:

- Registration of waste generation facilities.
- Waste Handling Permits.
- Waste Facility License.

The Draft Waste Management Rules define how waste should be transported, the storage of waste, import and export of waste, guidelines for landfills and waste incineration and the establishment of a Waste Management Register.

Hazardous waste is categorised into the rules by specific substances, characteristics of the substance and certain substances that have particular hazardous characteristics.

## 2.3 Water and Sewerage Act

The Water and Sewerage Act was passed in 1965 by the Government of Trinidad and Tobago. This legislation specified the details on the administration of the water and sewerage infrastructure of the country through the establishment of the authorising body, the Water and Sewerage Authority (WASA).

With respect to the San Fernando Wastewater Catchment Project, the Water and Sewerage Act stipulates that WASA is responsible for:

- Maintenance and upgrade of the existing sewerage system.
- Maintenance and upgrade of sewage works.
- Constructing and developing required sewage infrastructure.
- Administering the sewerage services.

The Water and Sewerage Act defines WASA's duty to construct and maintain the sewage services in accordance with the sanitary rules of the Public Health Ordinance. To fulfil this function WASA is allowed to do the following:



- Construct sewers in streets and houses.
- Install pumps, machinery and other associated sewer equipment.
- Employ contractors to carry out the construction, installation and repair of all sewerage infrastructure works.

WASA is allowed by the Act to separate any area within Trinidad and Tobago into sewer or wastewater catchments. WASA also has the power to give notice to any property owner that they are required to construct a water closet if none exists on the property and/or connect to any existing or proposed sewer mains or pipes. This regulation can only be enforced if the property has a sufficient water supply and if the collecting sewer is within 150 feet (approximately 46 m) of the house or building.

According to the Water and Sewerage Act, all persons or businesses must submit drawings and plans for the sewer system of the property to WASA prior to commencement of construction. These plans would be subject to the approval of the Authority and must therefore tie into any existing or proposed sewer mains.

The Act addresses issues with construction of the sewerage infrastructure including laying of sewer mains in roadways and footpaths. WASA or the contractor undertaking the sewage works must consult with the agency or person in charge of the road or foot trail. In the San Fernando Catchment area this would be the Regional and City Corporations and a few private owners. WASA or the contractor must give notice of the intention of the construction and time of commencement of works. In the case of roadways seven days notice is required and for footpaths 3 days notice is the maximum time for a notice to be issued.

The Water and Sewerage Act stipulates that WASA or the contractor employed must:

- Repair road or footpath to the standards of the agency in control and this must be done up to 3 months subsequent to completion of the works.
- Dispose of all garbage and waste from the construction.
- Implement a proper traffic mitigation plan.
- Ensure area is fenced, guarded and lighted if the trench is left open. Suitable arrangements must also be made to control traffic caused.

In addition, the Act states that the property owner or the person residing in the building is responsible for all costs associated with installing and repairing sewer connections. This fee if not paid prior to construction would be recovered as a civil debt.

The Water and Sewerage Act specifies that WASA can make laws to standardise the construction of sewer infrastructure and the materials that can be used. These rules can also be used to regulate the substance that can be deposited into the sewer system and define the person that is accountable for handling the costs to fix water closets and install or repair sewer connections. WASA is in the process of formulating some of the standards in the “Water and Wastewater Design Guideline Manual”, which was produced in March 2009. The specifications of this document are discussed in Section 2.3.1.



### 2.3.1 WASA – Water and Wastewater Design Guidelines

In March 2009 WASA produced Revision 1 to the Water and Wastewater Design Guideline Manual. This document is intended to be used as a map for the design of all water and wastewater infrastructure in Trinidad and Tobago. The manual refers to design specifications of wastewater collection systems and wastewater treatment plants, in particular, flows and loads, pipe material and sizes and electrical, mechanical, architectural and structural standards.

WASA has not yet officially adopted the document as a design manual for the works conducted by or on behalf of the Authority; however, it still can be used to guide the design specifications in the interim. The general design standards, wastewater effluent treatment standards, water reuse standards and septage and biosolids management will be discussed in this section since it is a foundation for the design guidelines that have been adopted by WASA for the San Fernando Project.

#### 2.3.1.1 General Design Guidelines

The WASA Water and Wastewater Design Guideline Manual highlights mandatory standards that have to be applied to all water and wastewater design projects undertaken by consultants. It includes material standards (**Appendix B.4**), codes and other design criteria that must be followed and flood proof design standards for WASA buildings and structures. Generally, the Manual outlines that the standards of the American Society for Testing and Material (ASTM) and American Water Works Association (AWWA) must be followed when designing and constructing all water and wastewater infrastructure.

The manual highlights the design specifications for the wastewater collection system such as; design flows, pipe sizes, pipe slopes, manhole distances, pipe material and sewer connections. The document does not particularly require the engineer to follow all the specifications but it is expected to guide the design of the collection system.

The WWTP and pump station design is also addressed in the Water and Wastewater Design Guideline Manual. The guidelines were formulated as a means of ensuring that the design of these structures are carried out sustainably and malfunctions are prevented as much as possible. The plant layout must allow room for future expansion of the facility and to utilize space adequately. The piping in the WWTP must be arranged so that if one unit is out of operation the facility can continue to function.

In terms of environmental effects, the manual speaks to different factors including wastes from the treatment process. Any waste created must be appropriately stored for re-treatment or transported to another treatment facility. Odour control must be addressed at the design stage of the WWTP and hydrogen sulphide gas detectors must be installed. The concentration of air pollutants according to the manual is presented in Table 2-4.

**Table 2-4 Air Pollutant Concentration at WWTP**

Air Pollutant	Concentration (mg/Nm <sup>3</sup> )
Hydrogen Sulphide (H <sub>2</sub> S)	<0.1
Amines	<0.07
Ammonia	<1
Mercaptans	<0.7

Odour control must be installed at the pump stations and has to cover a radius of 100 metres within residential areas.

Stormwater management is also summarised in the manual and requires that the WWTP be designed to reduce run-off at the facility. The WWTP must be designed to structurally withstand ground movement and a monitoring plan should be carried out upon completion of the facility. Commonly, monitoring stations should be located at the influent, effluent and after each unit treatment.

### 2.3.1.2 Wastewater Effluent Treatment Guidelines

The treatment guidelines present the effluent quality criteria for WWTPs. The guideline for the effluent are based on the Water Pollution Control Rules and modified to reflect stricter criteria. The manual states that secondary treatment is necessary to achieve the effluent criteria. It also gives the conditions for tertiary treatment and stipulates that the disinfection process is mandatory in all cases. The effluent standards dictated in the manual are presented in Table 2-5.

The San Fernando Wastewater Treatment Plant is designed to meet a higher effluent guideline than shown in Table 2-5 for inland surface water. Refer to Section 3 of this report.

**Table 2-5 Effluent Guidelines for WWTP**

Discharge Point	BOD (mg/L)	Suspended Solids (mg/L)	pH	Faecal Coliform (MPN/100 ml)	Total Residual Chlorine (mg/L)	Ammoniacal Nitrogen (mg/L)	Total Phosphorus (mg/L)
Inland Surface Waters	20	20	6 – 9	400	1	10	5
Inshore Sea Waters	50	150	6 – 9	400	1	10	5
Offshore Sea Waters	100	200	6 – 9	400	2	10	5
Environmentally Sensitive Areas	10	15	6 – 9	100	0.2	0.1	0.1

### 2.3.1.3 Water Reuse Guidelines

The Manual refers to the reuse of treated effluent for irrigation purposes. The document states that the effluent must have undergone tertiary treatment before it can be re-used for agricultural activities. The



design of the WWTP can encompass the re-use of the treated effluent for watering plants close to and within the WWTP.

#### 2.3.1.4 *Septage and Biosolids Management*

Septage collected from septic or holding tanks, as well as pit latrines will be treated at the San Fernando WWTP. The Manual allows the use of stabilisation lagoons for the treatment of septage; however, a thorough investigation of soil and hydrogeological conditions must be conducted to suitably site the lagoons. The area positioned for the stabilisation lagoons or ponds should be properly fenced and a sign indicating the presence of a sewage pond must be used according to WASA's Design Manual.

Stabilization lagoons are not proposed as part of the design of the San Fernando WWTP. A septage receiving station is proposed to receive incoming septage and treat it in the new WWTP. The design is addressed in Section 3 of this report.

Biosolids will be produced at the proposed San Fernando WWTP when stabilized solids are removed from the aerobic digesters. Based on the Manual, the Biosolids can be thickened and disposed through one of the following methods:

- For agricultural purposes as nutrient sources.
- Dewatered and disposed at an appropriate landfill site.
- Dewatered and turned into pellets for farming.
- Dewatered, dried and incinerated to be used as an energy source at the WWTP.

The manual describes sludge drying beds as an option for this treatment. The design must consider average rainfall, humidity, liquid runoff, and provisions for heavy rainfall events by covering the beds, accelerating the dewatering process, extra storage facilities or alternate dewatering methods.

Sludge drying beds are not proposed as part of the design of the San Fernando WWTP. The design of the solids processing system is discussed in Section 3 of this report.

## 2.4 Forest Act

The Forest Act was enacted in 1916 and amended on several occasions subsequent to that, with the most recent amendment in 1999. The Act refers largely to the felling, burning and transporting of timber without permission. Timber is defined as any tree listed in the Second Schedule of the Act whether they are standing, fallen, living or dead (**Appendix B.5**). The following activities are prohibited within the designated Forest Reserves:

- Cattle grazing or trespassing.
- Felling, cutting, girdling, marking, lopping, tapping, bleeding, injury by fire of timber.
- Dragging or cutting of timber that may result in damage to other trees.
- Alights any fires outside of the periods allocated by the relevant authorities.
- Removing forest produce in designated areas.
- Entering a prohibited area.



The Act designates protected forested areas called Forest Reserves, these include:

- Mount Hope Estate
- Caroni Swamp

No part of the San Fernando Project area has been designated as a Forest Reserve therefore the regulations pertinent to Forest Reserves in the act would not be applicable for this project.

## 2.5 Fisheries Act

The Fisheries Act was passed in 1916 and no amendments have been issued to date. The term fish in the Act is defined as follows:

- Oysters
- Shrimps
- Turtles
- Corals
- Other marine fauna

The areas covered in the Fisheries Act include all rivers and territorial seas defined according to other laws of Trinidad and Tobago.

The Act addresses different issues with reference to the capture, sale and trade of fish. Generally the Act depicts the method by which fish can be caught and the equipment that can be used (**Appendix B.6**). The use of poison or explosives to injure or kill fish is prohibited according to this regulation. The size and type of fish species that cannot be captured and as a result sold or manufactured are also mentioned in the Act.

According to the Fisheries Act no fish or shellfish can be taken in certain areas. In the San Fernando Wastewater Project area, the body of water between Claxton Bay and the mouth of the Ciperu River is prohibited for taking any fish. This regulation also includes the capture of oysters, crabs and shrimps.

The protection of turtles also falls under this legislation. The rule refers to the capturing or killing of turtles in different coastal areas. According to the Act, it is illegal to kill or capture a turtle between the periods of March 1<sup>st</sup> to September 30<sup>th</sup>. Even though the project does not entail any fishing activities, the baseline environmental study included a fish survey. The method by which the fishes were captured abided by this regulation and is described in **Appendix D.5**.

## 2.6 Plant Protection Act

The Plant Protection Act was enacted in 1975 and amended in 2001. The general notion of the Act is to regulate the importation of plant species that would impact on local plants species. The regulation also seeks to protect local plant species from infection by plant pests that may have been transported during the importation of the foreign plant species. The plants that would be used for landscaping of the San Fernando Wastewater Treatment Plant would follow all the regulations stipulated in this act and would ensure that the plants are permitted and registered with the relevant authorities.





## 2.7 Conservation of Wildlife Act

The Conservation of Wildlife Act was enacted in 1963 to regulate the hunting and gaming procedures of Trinidad and Tobago. The Act refers to the granting of permits and the activities that could be undertaken with a State Game License or Resident's License. Hunting seasons and gaming sanctuaries are also assigned in this act. The closest gaming sanctuaries according to the First Schedule are:

- Southern Watershed Game Sanctuary:
  - Northern boundary; southern watershed reserve
  - Eastern boundary; Morne Diablo Road
  - Western boundary; Sea
  - Southern boundary; Quinam Road
- Morne l'Enfer Game Sanctuary:
  - Northern boundary; Forest Reserve Main Road
  - Eastern boundary; Bungalow and No. 20 Roads
  - Western boundary; Blue Basin and No. 31 Roads
  - Southern boundary; New Camp Road

Persons with a Resident's License are entitled to hunt animals for scientific research, zoology records or eradication of animals designated as vermin. The Third Schedule of the Act specifies the animals that are considered vermin or pests to the local habitats and the Second Schedule lists all animals that can be hunted in gaming sanctuaries during hunting seasons. These schedules are attached in **Appendix B.7**.

## 2.8 Occupational Safety and Health Act

The Occupational Safety and Health (OSH) Act was passed in 2004 by the Government of Trinidad and Tobago. The Act lists a wastewater treatment plant as a factory where it is defined as "premises in which persons are employed to supply and maintain services in connection with water and sewer". State-owned establishments are not exempt from abiding by the regulations of this act nor any work carried out on behalf of the State nor work conducted that is vital to national welfare.

The OSH Act stipulates the duty of the employer to ensure the safety and welfare of all employees. The services that the employer must provide include:

- Provision and maintenance of equipment used on site.
- Ensuring risks to health are prevented in terms of machinery and substances at the site.
- Provision of protective clothing and devices.
- Provision of information and training to ensure the safety of employees.
- Ensuring risks to health are prevented with relation to entrance and exit to the site.
- Ensuring risks to health are prevented in connection with amenities.
- A policy statement on safety and health of the employees.



The Contractor employed to conduct work on behalf of WASA must formulate an emergency plan that will comprise details on first aid help, transportation from the site to the nearest hospital or health centre, the measures taken to control a fire, evacuation scheme and methods by which appropriate personnel are notified.

As a result of the OSH Act, an OSH Authority governs and oversees the compliance of this legislation. A Chief Inspector will be assigned whose responsibility is to investigate and visit the workplace to ensure the employers abide with these rules. In some cases, the Chief Inspector can ask the employer to appoint a Safety Practitioner within the establishment who would ensure compliance to the OSH Act.

The OSH Act mentions not only the responsibility of the employer to ensure the safety of the workers but also to the employees. Employees have a duty to care for their own safety and those of the persons around them. The employee must also follow all responsibilities assigned by employer including the use of protective clothing and devices and any breach of the OSH Act must be reported by the employee to the employer.

Mention is also made of technology and machinery in the OSH Act. The designers, employers and employees must be aware of the risk of operating it and the liability as a result of improper installation. Specifics of certain machinery and equipment are also highlighted in the Act.

Fire emergency and response is addressed in the OSH Act. This is relevant to the San Fernando Wastewater Project since any establishment that “stores substances that are explosive or highly flammable” is subjected to the regulations regarding fire in the Act. The employer must ensure that the building is certified by the Fire Authority and an appropriate fire escape is installed. Based on the number of employees; warning signs, evacuation drills and fire equipment training must be carried out.

There are other basic amenities that must be provided by the employer at the treatment plant. These include; an adequate supply of drinking water, lockable washing facilities and changing rooms for men and women separately, first aid and a lunch or rest room. According to the Act, these facilities must be installed by law and are included in the WWTP design.

## 2.9 Trinidad and Tobago Bureau of Standards

The Trinidad and Tobago Bureau of Standards was made law in 1997 when the Standards Act was passed in the Government of Trinidad and Tobago. This act mandated that the Bureau develop and establish standards that;

- Improve goods produced in Trinidad and Tobago.
- Ensure industrial efficiency and development.
- Promote public and industrial welfare, health and society.
- Protect the environment.

As part of the scope of the organization two standards have been formulated to protect the environment from industrial and domestic waste; the specification for the liquid effluent from domestic wastewater



treatment plants into the environment, and the specification for the effluent from industrial processes discharged into the environment.

### 2.9.1 Specification for the Liquid Effluent from Domestic Wastewater Treatment Plants into the Environment

This standard coded TTS 417:1993 was formulated to prevent pollution and regularise the discharge of effluent into the environment. The standard outlines permissible levels for different parameters in varied environments. Environmentally sensitive areas are also considered in the standard and are defined by the ESA Rules as discussed in Section 2.2.6 they also include the following areas:

- Recreational waters
- Irrigation waters
- Waters used as a food source and for a potable supply
- Waters that impact on human health

Table 2-6 presents the limits of these parameters as stated in the standard for liquid effluent from domestic wastewater treatment plants.

**Table 2-6 Maximum Permissible Levels for Liquid Effluent from Domestic Wastewater Treatment Plants (TTS 417:1993)**

Parameter	Receiving Environment			
	Inland Surface Water	Inshore Marine Areas	Offshore Marine Areas	Environmentally Sensitive Areas
5-day BOD (mg/L)	25	25	175	25
Suspended Solids (mg/L)	30	30	175	30
pH	6 - 9	6 - 9	6 - 9	6 - 9
Faecal Coliforms (CFU/ 100 ml)	4000	4000	4000	400
Total Residual Chlorine (mg/L)	0.1	0.1	0.1	0

### 2.9.2 Specification for the Effluent from Industrial Processes Discharged into the Environment

This specification is another means by which the Bureau of Standards promotes environmental protection. This standard coded TTS 547:1998 lists the voluntary criteria for the discharge of effluent into the environment. This specification would still be applicable to the San Fernando Wastewater Project because it defines the permissible parameters of the wastewater discharged from industries in the San Fernando area. Table 2-7 depicts the maximum levels for each parameter when wastewater is discharged into different receiving environments.

**Table 2-7 Permissible Limits for Effluent Discharge from Industrial Processes (TTS 547:1998)**

Parameter	Receiving Environment			
	Inland Surface Water	Inshore Marine Areas	Offshore Marine Areas	Environmentally Sensitive Areas
5-day BOD (mg/L)	30	50	100	10
COD (mg/L)	250	250	250	60
TSS (mg/L)	50	150	250	15
n-Hexane Extractable Material (mg/L)	10	15	100	0
Ammoniacal Nitrogen (mg/L)	10	10	10	0.01
Phosphorus (mg/L)	5	5	5	0.1
Sulphide (mg/L)	1	1	1	0.2
Chloride (mg/L)	250	-	-	250
Total Residual Chlorine (mg/L)	1	1	2	0.2
Hexavalent Chromium (mg/L)	0.1	0.1	0.1	0.1
Total Chromium (mg/L)	0.5	0.5	0.5	0.1
Iron (mg/L)	3.5	3.5	3.5	1
Nickel (mg/L)	0.5	0.5	0.5	0.5
Copper (mg/L)	0.5	0.5	0.5	0.01
Zinc (mg/L)	2	2	2	0.1
Arsenic (mg/L)	0.1	0.1	0.1	0.05
Cadmium (mg/L)	0.1	0.1	0.1	0.01
Mercury (mg/L)	0.01	0.01	0.01	0.005
Lead (mg/L)	0.1	0.1	0.1	0.05
Cyanide (mg/L)	0.1	0.1	0.1	0.01
Phenol (mg/L)	0.5	0.5	0.5	0.1
Faecal Coliforms (CFU/100 ml)	400	400	400	100

## 2.10 National Policies

The Government of Trinidad and Tobago has implemented a number of national policies, some are still in the draft stage. These national policies are meant to guide decision-making and other regulations formulated as a result. The policies applicable to the San Fernando Wastewater Project are:

- National Environmental Policy



- National Wetlands Policy
- Draft National Protected Areas Policy
- Draft National Forest Policy

### 2.10.1 National Environmental Policy

The National Environmental Policy (NEP) was first formulated in 1998 and revised in 2005 by the EMA. The NEP was mandated as part of the Environmental Management Act and was compiled by the Directors of the EMA. The Policy has specific objectives which include:

- Prevention, reduction, recycling of pollution.
- Conservation of the vitality and diversity of the natural environment.
- Sustainable use of renewable resources and conservation of non-renewable resources.
- Changing attitudes and practices of citizens.
- Installation of Environmental Management Systems in all industries.
- Empowerment of stakeholders and communities to care for their environment.
- Promoting environmental sustainable development into country policies and programmes.

The NEP takes on specifics of sustainable development in Trinidad and Tobago and follows four broad principles.

The first principle is conservation of natural resources. This section as discussed in the NEP refers to ESA, ESS, coastal and marine areas, forests, wetlands, water and mineral resources and energy. These components of the natural environment have to be addressed according to the Policy to maintain biodiversity that may be impacted by development. Another pertinent initiative out of the policy is the “management of greenhouse gas (GHG) emissions and other forms of pollution resultant from energy conversion and end-use”. The mandate is for energy efficient technology to be employed to minimize pollution that will be considered in the design of the WWTP and equipment used for construction of the collection system.

Pollution, hazardous and toxic substances is the second principle addressed in the NEP. The types covered were air, noise, motor vehicle emissions, ozone depleting substances, greenhouse gases, wastes, hazardous waste, hazardous substances and spills, contaminated land, natural disasters and environmental emergencies. Most applicable to the San Fernando Wastewater Project is the stance that the NEP recommends on waste. The NEP instructs that Government will:

- Encourage the prevention and reduction of waste. This would be achieved specifically through clean technologies, disposal of dangerous substances in waste that will be recovered and development and marketing of products designed to minimally impact the environment.
- Encourage recycling, reuse or reclamation of waste.
- Ensure waste is recovered or disposed without hampering human health. The processes employed should not harm the environment through noise, odour or aesthetics.
- Establish and integrated waste disposal installation.

These initiatives are relevant to the treatment of wastewater and the disposal of the sludge and other wastes generated in the treatment process. The methods used follow the plans outlined in the NEP.



The third principle of the NEP was assessment of impacts, public information and environmental education. The environmental impact assessment as referred to in the NEP is significant for the San Fernando Wastewater Project since it is a rule that must be followed. This aspect of the Policy speaks to the designated activities requiring a CEC and the threshold of its activity. The proposed list in the NEP does not differ from the current List of Designated Activities, WPR 2001; however, the NEP refers to the issue of standards relevant to these activities. The general concept is for the development to follow a similar standard but not one that is less stringent than other countries.

The economic aspect of the NEP is the fourth principle in this document intended to promote and attain sustainable development. The Policy seeks to find financial instruments that will encourage environmental awareness. Pertinent to the San Fernando Wastewater Project, the Government proposes to revise legislation that would guarantee the polluter is liable for consequences of the polluting activity and ensure that responsibility is held from a financial standpoint.

### 2.10.2 National Wetlands Policy

The National Wetlands Policy was formulated as a result of the Convention on Wetlands that took place in Iran in 1993. The Convention details will be discussed in Section 2.11. The Forestry Division of the Ministry of Agriculture, Land and Marine Resources was designated as the focal point. A National Wetlands Committee was established in 1995, which was delegated to compile the National Wetlands Policy. The document was approved by Cabinet in 2001. **Appendix B.8** contains the preliminary list of wetland sites.

The rationale for a National Wetlands Policy is generally to conserve the wetlands of Trinidad and Tobago because of the many benefits from this environment. The definition of wetlands as adapted in this Policy has the same meaning as applied in the Convention on Wetlands, 1993. “Wetlands are areas of marsh, fen, peatland or water, whether natural or artificial, permanent or temporary, with water that is static or flowing, fresh or brackish or salt, including areas of marine water the depth of which at low tide does not exceed six metres”. The benefits of wetlands are:

- Employment.
- Exploitable resources including; timber, charcoal, tannins, plants and fish.
- The environment support marine resources and coral reef environments.
- Floodwater retention.
- Groundwater aquifer recharge.

Pertinent to the San Fernando Wastewater Project the National Wetlands Policy refers to the contribution of malfunctioning wastewater treatment plants to wetland degradation. The Policy briefly explains that the wastewater from these WWTPs is discharged into drainage channels that eventually flow into wetlands impacting negatively on the wetland habitat. Appended to the Policy document is a list of known wetland areas in Trinidad and Tobago; however, it does not include all. The wetlands at Marabella are included in the list as estuarine mangrove and are approximately 10,000 m<sup>2</sup> in area. There was also another swampy-marshy area identified in the fauna investigations of this project and will be discussed in Section 5.

There are a number of initiatives underlined in the National Wetlands Policy; however, the main one relating to the San Fernando project is through exemplifying practices supporting wetland conservation



in all government programmes. The method by which this will be achieved is through liaison between State agencies, the National Wetlands Committee and other stakeholders to prepare and implement a wetland management plan which will entail monitoring of the wetland. The Policy also mandates the implementation of an institutional and legislative framework of conservation of wetlands.

### 2.10.3 Draft National Protected Areas Policy

The draft version of the National Protected Areas Policy was completed in May 2009. The draft Policy was submitted for public consultation in April 2010. According to the National Protected Areas Policy a protected area is an area of land, body of freshwater or sea or combinations of these that are managed through legal or effective means to:

- Conserve biological diversity.
- Maintain ecosystem goods and services and facilitate sustainable land use.
- Provide recreational, educational, and cultural opportunities and facilitate the development of sustainable livelihoods.

There are currently some sites legally designated as Protected Areas, they include:

- Forest Reserves, based on the State Lands Act.
- Wildlife Sanctuaries, based on the Conservation of Wildlife Act.
- Prohibited Areas, based on the Forest Act.
- National Parks, based on the Chaguaramas Development Act.
- Protected Marine Areas, based on the Marine Areas (Preservation and Enhancement) Act.
- Environmentally Sensitive Areas based on the ESA Rules.
- Heritage Sites, based on the National Trust Act.

There are also some areas that are not Protected Areas by law but in practice. The San Fernando Hill is an example of a Protected Area designated in this regard within the San Fernando Wastewater Catchment. There is also an incentive by Ministry of Local Government to allocate National Heritage Parks across Trinidad and Tobago. To date none have been assigned in the project area but the Devil's Woodyard is an example of a proposed area; however this is not in the project boundaries.

The draft National Protected Areas Policy names WASA as a relevant agency that is mandated with the responsibility of designating protected areas. One of the functions of WASA is to prohibit or regulate activities undertaken in watersheds so that potential pollution can be prevented. In this regard WASA has the task as many other stakeholders do, to care for and oversee the Protected Areas of Trinidad and Tobago.

Overall, the goal of the National Protected Areas Policy is to:

- Designate and classify Protected Areas across Trinidad and Tobago.
- Institutionalise the sustainable management of Protected Areas.
- Develop methods of sustainable financing to oversee the implementation of the policy and associated legislation.
- Identify the human resource needs for attaining policy objectives.
- Resolve conflicts associated with other relevant policies.



- Develop legislation for Protected Areas.

#### 2.10.4 Draft National Forest Policy

The draft National Forest Policy was produced in June 2008 by the Ministry of Planning, Housing and the Environment. The first policy was created in 1942 when Trinidad and Tobago was still a British Colony. This policy was then revised in 1981 by the Conservator of Forests. In 1998, another draft Forest Policy was created and presented in Cabinet in 1999. The decision was made to present this new policy as a green paper; however, this has not been accomplished.

The draft Forest Policy completed in 2008 was a revision to the 1999 policy. The document has been submitted for public review and consultations were held from March to April 2010. The term forest includes natural and plantation forest and is defined as “ecosystems occurring on areas of land with existing or potential tree canopy of at least 50% covering a minimal land area of 0.4 ha”. The Forest policy categorises existing forested areas within Trinidad and Tobago into different regimes, these include:

- Production forests
  - Teak plantations
  - Pine plantations
  - Natural forests
- Protection forests
  - Areas above 90 m contour
  - Proposed national parks
  - Prohibited areas
  - Certain wildlife sanctuaries
  - Nature reserves
  - Dams
  - Wild belts within Forest Reserves
  - Some private forested areas

Despite the fact that the existing San Fernando WWTP is not situated on a Forest Reserve the Forest Policy names certain activities that may cause forest degradation. Relevant to the San Fernando Wastewater Project forest degradation is caused by “increasing physical development of land for industrial and commercial activities, including roads, pipelines, utility right-of ways (ROW), oil and gas infrastructure, tourism and public infrastructure”.

The main objective of the Forest Policy is to act as a guideline to sustainable management of forest resources. The policy outlines a number of initiatives to bring about change in the way forested areas are managed and conserved. Some of these initiatives are more applicable to the San Fernando Wastewater Project and can be implemented within the main framework of the project. One initiative relevant to the San Fernando Wastewater Project is maintenance and enhancement of the natural productivity of forest ecosystems and ecological processes. The methods by which this will be implemented, according to the Forest Policy are as follows:





- Ensure lands best suited for provision of forest products remain under forest cover.
- Identify, protect and manage areas providing key ecological services.
- Manage forests to ensure maintenance of evolutionary and ecological processes.
- Promote reforestation and rehabilitation of forests.
- Utilize forest and component biodiversity as an early warning system for pollution effects.

## 2.11 Multilateral Agreements/Conventions

There are a number of treaties and conventions that Trinidad and Tobago have ratified that relate to environmental protection. The list is presented in Table 2-8 and includes all treaties in various environmental fields that Trinidad and Tobago are signatory to. The most official form of sanctioning these agreements is through ratification and for most of these treaties Trinidad and Tobago has done so.

**Table 2-8 List of Multinational Agreements, Treaties and Conventions Ratified by Trinidad and Tobago**

Treaty/Convention	Year Entered Into Force	Year Ratified by Trinidad & Tobago
Convention on Nature Protection and Wildlife Preservation in the Western Hemisphere	1942	1942
International Plant Protection Convention	1952	1970 (adherence)
Geneva Convention on the High Seas	1962	1962
Treaty Banning Weapon Tests in the Atmosphere, in Outer Space and Under Water	1963	1963
Convention on the Territorial Sea and the Contiguous Zone	1964	1964
Geneva Convention on the Continental Shelf	1964	1968
Convention on Fishing and Conservation of the Living Resources of the High Seas	1966	1966
Convention Concerning the Protection of the World Cultural and Natural Heritage	1972	2005
Convention on International Trade in Endangered Species of Wild Fauna and Flora (CITES)	1975	1984
Convention on Wetlands of International Importance (RAMSAR Convention)	1975	1993
Vienna Convention on Civil Liability for Nuclear Damage	1977	1977 (accession)
UN Convention on the Law of the Sea	1982	1994
Convention for the Protection and Development of the Marine Environment of the Wider Caribbean and its Protocols concerning co-operation in combating oil spills in the wide Caribbean Region	1986	1986
Vienna Convention Protection of the Ozone Layer	1988	1989
Lome IV Convention	1989	1989
Montreal Protocol on Substances that Deplete the Ozone Layer	1989	1989

**Table 2-8 List of Multinational Agreements, Treaties and Conventions Ratified by Trinidad and Tobago (continued)**

Treaty/Convention	Year Entered Into Force	Year Ratified by Trinidad & Tobago
Protocol Concerning Pollution from Land-based Sources and Activities	1999	1999
Cartagena Protocol on Biosafety	2000	2000
Stockholm Convention on Persistent Organic Pollutants	2001	2002
Rotterdam Convention on the Prior Informed Consent Procedure for Certain Hazardous Chemicals and Pesticides in International Trade	2004	2009
Convention on the Conservation of Migratory Species of Wild Animals	2010	Not yet ratified
Protocol Concerning Specially Protected Areas and Wildlife (SPA Protocol)	1990	1990
Basel Convention on the Control of Transboundary Movement of Hazardous Wastes and their disposal	1992	1994
UN Framework Convention on Climate Change	1992	1994
UN Framework Convention on the Conservation of Biological Diversity	1993	1996
Convention to Combat Desertification	1994	2000
International Tropical Timber Agreement	1997	1997
Kyoto Protocol	1997	1999
Montreal Protocol on Substances that Deplete the Ozone Layer (Amended London, 1990; Copenhagen, 1992; Vienna, 1995; Montreal, 1997; Beijing, 1999)	-	-

## 2.12 Approval Agencies

The environmental regulatory and legislative framework of Trinidad and Tobago is managed by different organizations with each agency having a separate portfolio from the other. These agencies include:

- Environmental Commission
- Town and Country Planning Division
- Municipal Corporations
- Ministry of Works and Transport

The EMA is another approving agency that is responsible for ensuring sustainable development is attained. The functions of the EMA were discussed in Section 2.2.1.



### 2.12.1 The Environmental Commission

The Environmental Commission is the judicial body that exercises the environmental regulations that exist in Trinidad and Tobago. The Commission is a superior court made up of a Chairman and Deputy Chairman who must be attorneys-at-law, and other technical staff. The body was formulated out of the Environmental Management Act and the main function is to adjudicate applications, appeals and complaints. Specific responsibilities of the Commission are:

- Hearings and decision-making
- Alternate dispute resolutions
- Staff processing of hearings
- Public relations
- Public access to information

The Environmental Commission is mandated to hear appeals made by companies when applications such as that of a CEC are denied. The jurisdiction of the court is mainly concerning actions made by the EMA.

### 2.12.2 Town and Country Planning Division

The Town and Country Planning Division (TCPD) is a department within the Ministry of Planning, Housing and the Environment. It was established as part of the Town and Country Planning Act. The mandate of the TCPD was to administer the use and development of all land in Trinidad and Tobago through development planning and development control. The specific functions are:

- Establish a national physical development planning framework for regional and local area plans that would be utilised for decision-making purposes and to guide development accordingly.
- Review applications for planning permission.
- Review applications for display of advertisements.
- Enforce planning control.
- Assist in the preparation and review of planning legislation.
- Compile a database of land use planning data in Trinidad and Tobago.
- Compile a register of all planning applications.

The TCPD is responsible for granting planning permission for proposed developments on both privately and state-owned land. There are two forms of planning permission; outline and full. Outline planning approval is to be pursued by all developments. The purpose of outline planning approval is to ensure consistency between the type of development and the land use policy for the proposed site.

Full planning approval is sought by specific types of activities, this includes:

- Building operations (erection and renovation).
- Land or building use change.
- Retention of an existing building.
- Land subdivision.
- Cutting, clearing, grading or filling activities.
- Road and drain construction.



The San Fernando Wastewater Project includes some of these activities and would therefore require both outline and full planning approval before construction commences. The TCPD monitors proposed development in Trinidad and Tobago by reviewing CEC applications prior to submission by the EMA. The procedure when applying for a CEC is to submit the completed application to the TCPD regional office closest to the location of the development. The TCPD then peruses the application to determine the type of development, location and what type of, if any, planning permission is required.

### 2.12.3 Municipal Corporations

Municipal Corporations of Trinidad and Tobago were established under the Municipal Corporations Act, 1992 and falls under the Ministry of Local Government. The corporations are operated by an elected Council comprising a Mayor who heads the Council and a Chairman who leads the corporation. The general role of the municipal corporations is to make policies and bye-laws. Different villages and communities comprise specific corporations and the corporation is responsible for maintaining the aesthetics and infrastructure within the area. The San Fernando Wastewater Catchment Area covers three municipal corporations. They are:

- San Fernando City Corporation, which includes the following collection system subcatchments:
  - Cocoyea
  - Tarouba
  - St. Joseph Village
  - Les Efforts
  - Ciperó
  - La Romain
  - Gulf View
  - Marabella
  - Vistabella
  - Mon Repos
  - Navet
  - Pleasantville
  - Spring Vale
  - Paradise
- Princes Town Regional Corporation, which includes the following collection system subcatchment:
  - Corinth
- Penal/Debe Regional Corporation, which includes the following collection system subcatchments:
  - Palmiste
  - Union Hall

The city and Regional Corporations are responsible for different aspects of infrastructure and public health within the various communities. These responsibilities are:

- Garbage collection.



- Cesspit and septic tank emptying.
- Construction and maintenance of roads other than main roads and highways.
- Construction and maintenance of drains, bridges, pavements and street signs.
- Street lighting.
- Maintenance of water courses.
- Maintenance of cemeteries and cremation sites.
- Maintenance of recreational areas.
- Maintenance of markets.
- Inspection of buildings and development sites.
- Approval of building and housing plans.
- Cleaning public spaces.
- Vector control.
- Disaster management.
- Provision of truck-borne water in dry seasons.
- Collection of land and building taxes.
- Establishment and enforcement of by-laws.

With these functions, the municipal corporations are an approving agency. The development plans would have to be reviewed and approved for the San Fernando Wastewater Project and the relevant corporations have been made aware of the project. The Water and Sewerage Act also states that during installation of sewer or water mains the municipal corporation must supervise and ensure that the road is restored according to an acceptable standard.

#### **2.12.4 Ministry of Works and Transport**

The Ministry of Works and Transport (MOWT) is responsible for all major roads, secondary roads and highways in Trinidad and Tobago. MOWT main functions are construction and maintenance of the major roads and major waterways. The proposed sewer layout will be in road right of ways, with many road and waterway crossings. The details of the design are in Section 3 of this report. Liaison has been made with both the Highways Division and Drainage Division of the MOWT in order to introduce the project and the development plans respective to major roads and water courses in San Fernando and environs.



## 3. Project Description

### 3.1 Objective

The objective of this section is to outline, and where possible, provide detailed information on the proposed project in accordance with the EIA TOR for CEC 1597/2006. The project description addresses details of the collection and treatment of the wastewater, labour requirements, activities associated with pre-construction (i.e. enabling works), and construction phase activities. The project description also addresses those activities that will occur during the operational life of the treatment plant and collection system. Non-routine (i.e. accidental) events are discussed, followed by the decommissioning stage.

The design of the San Fernando Wastewater Project has the following objectives:

- Identify the most effective and optimal regional arrangement of the wastewater systems within the city of San Fernando and its environs from a technical, operational, and cost standpoint.
- Prepare detailed designs and tender documents for the rehabilitation of the existing wastewater collection systems within the city of San Fernando and its environs, and for the construction of new wastewater collection systems in areas that are presently not serviced.
- Prepare detailed designs, and tender documents for the construction of one new WWTP.
- Design the wastewater treatment plant to ensure the effluent complies with the Draft Water Pollution Rules, 2001 (as amended).
- Design the collection system and treatment facility to serve communities up to the design horizon of 2035, at minimum investment and operations costs.

### 3.2 Project Background

The city of San Fernando is the second largest urban centre in Trinidad. It is the commercial hub of south Trinidad and has been steadily expanding with the growth of the oil and gas sector and downstream activities in south Trinidad. The city of San Fernando's current population is approximately 55,400. The city is serviced by a wastewater collection, treatment and disposal system built in the 1960's and owned and operated by WASA. This collection system has approximately 72 km of piping, and services approximately 25,000 of the city's population. The wastewater treatment plant was originally designed to treat 20 ML/d. A septage receiving station was constructed at the San Fernando plant in the 1980's.

The wastewater system has functioned adequately for a number of years but has passed its useful design life and is in need of major rehabilitation and expansion to meet the current and future needs of the city and surrounding areas. Field studies have revealed that sections of the existing collection system are in need of replacement as some visible sections of trunk sewer have broken open and fallen into drains and rivers, allowing untreated wastewater into the waterways.



The areas outside of the existing San Fernando collection system have experienced significant development over the past several years. The estimated population of the surrounding areas outside the city limits is approximately 47,600. Numerous private and government housing, commercial and institutional developments have emerged along with separate wastewater collection systems, pump stations and packaged wastewater treatment plants (WWTPs), most not maintained by WASA. These areas include Harmony Hall, Tarouba, Pleasantville, Palmiste, and Gulf View. In addition, approximately 70% of developed areas surrounding San Fernando are not sewered, and are serviced by on-lot systems including septic tanks, soak-aways, and pit latrines. The conditions of these existing systems vary; however, the majority of the systems are not functioning or only partially functioning, resulting in untreated or partially treated wastewater entering waterways.

WASA intends to improve the wastewater sector in the city of San Fernando and environs by expanding the sewered service area and improving the level of wastewater treatment for existing and new customers in the rapidly developing area. The end result of the project will be an integrated and centralized wastewater system that provides a cost-effective and sustainable wastewater collection and treatment for the city of San Fernando and environs. The main benefits of the project include:

- Reduction in public health risk associated with untreated wastewater discharges into drains, rivers and other water courses.
- Improvement of water quality in the Guaracara, Marabella, Vistabella and Cipero Rivers that currently receive wastewater discharges.
- Overall improvement to the surrounding environment through the proper collection, treatment and disposal of wastewater that is presently adversely affecting the environment.
- Potential for production of up to 45 ML/d of reclaimed water that is suitable for irrigation and other non-potable uses in the area.
- Overall improvement in the quality of life for the citizens of San Fernando and environs.

### 3.3 Project Boundaries

The project boundaries are roughly defined by the Guaracara River in the North, Solomon Hochoy Highway including Ste. Madeline in the East, housing development within the M2 Ring Road in the South, and Gulf of Paria in the West. The boundaries are indicated by the dashed yellow line in Figure 3-1.

Major roads located within the project boundary include the Solomon Hochoy Highway, San Fernando By-Pass, Lady Hailes Road, South Trunk Road, Naparima Mayaro Road, and Tarouba Link Road.

Rivers located within the project boundary include the Guaracara, Marabella, Vistabella, and Cipero. Ally's creek and other un-named drains channel water in the wet season.



Figure 3-1 Project Boundaries, Roads and Rivers





### 3.4 Land Use and Population

Land use within the catchment is mainly residential, along with commercial, industrial and institutional uses. Commercial land use is primarily along main roads in the catchment, such as the Southern Main Road, San Fernando By-Pass Road, and the Southern Trunk Road. Industrial land uses are primarily concentrated within industrial estates areas such as the eTeck Harmony Hall Industrial Estate in Marabella, and along the north bank of the Ciperu River. Institutional land uses include schools, recreation centres, and hospitals are found throughout the catchment. These include the San Fernando Technical College and San Fernando General Hospital.

A land use category map was developed, and the results illustrate that over 60% of the project area is currently developed by human activities (Figure 3-2).

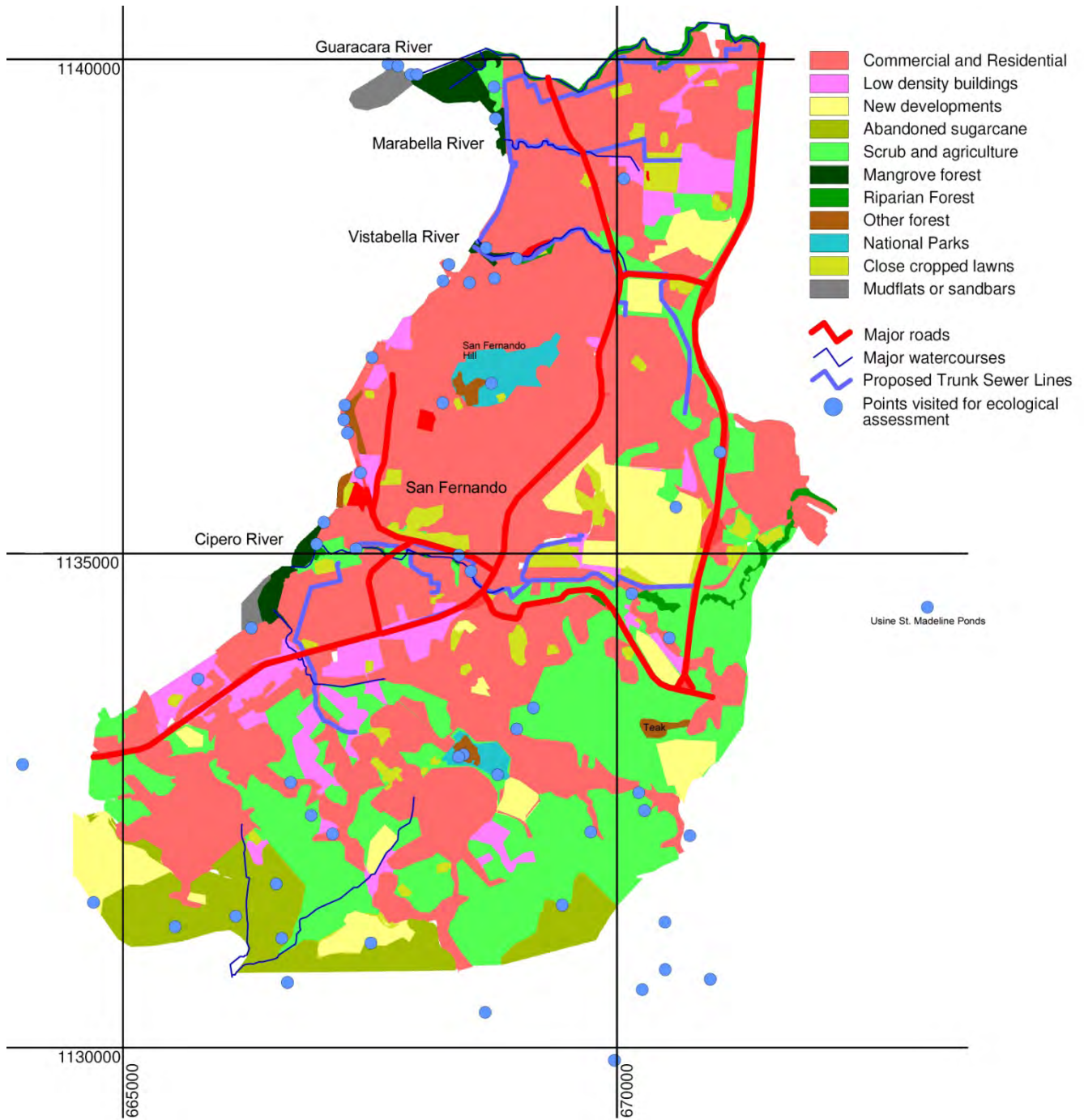


Figure 3-2 Map of San Fernando and Environs Showing Land Use (White, 2009)



The projected population was determined through satellite imagery housing counts and forecasting undeveloped land (i.e., abandoned sugarcane, scrub and agriculture) to the project design life of 2035. These numbers were verified with development plans from the San Fernando Regional Corporation, and other sources.

**Table 3-1 Summary of Population Projections**

Population Projection	2000	2009	2035
2000 Census	89,200	-	-
Satellite Housing Counts with Future Developments	-	90,200	111,600

### 3.5 Existing Sewered Areas

The San Fernando City subcatchment is approximately 7 km<sup>2</sup> and is served by a centralized wastewater collection, treatment and disposal system owned and operated by WASA. The largest sewered areas outside of the San Fernando City subcatchment are the Palmiste Development (1.4 km<sup>2</sup>), Union Hall Development (0.8 km<sup>2</sup>) and Gulf View Development (0.7 km<sup>2</sup>). Smaller systems exist throughout the project area. There are 9 WWTPs and 13 lift stations (LS) within the catchment boundaries. Of the 9 WWTPs, 5 are operating; however, inspections reveal that effluent quality is typically poor. Effluent from these WWTPs is discharged into the nearby watercourses. Of the 13 lift stations, 4 are operating. Of the remaining 9, 2 are under construction, and 7 are in a state of disrepair and not operational. Details are shown in Table 3-2. These poorly functioning wastewater systems result in improperly treated wastewater being discharged into the environment.

**Table 3-2 Existing Lift Stations and WWTPs in San Fernando Area**

Facility	Operational Status	Owner
<b>Lift Stations</b>		
Corinth HDC LS	Newly constructed but not commissioned	Private
Gulf View Development LS	Appears to be operational	Private
Harmony Hall LS	Operational	WASA
Kelvin Avenue LS	Not operational. Construction never completed	Private
Palmiste Boulevard LS	Constructed but not operational	Private
Pleasantville LS	Operational	WASA
Pollonais Crescent #1 LS	Constructed but not operational	Private
Pollonais Crescent #2 LS	Constructed but not operational	Private
Retrench HDC (Hillcrest Gardens) LS	Under construction	Private
Tarouba North LS	Constructed but does not appear to operational	Private

**Table 3-2 Existing Lift Stations and WWTPs in San Fernando Area (continued)**

Facility	Operational Status	Owner
Tarouba Heights LS	Operational	Private
Union Hall #1 LS	Not operational	WASA
Union Hall #2 LS	Not operational	WASA
<b>WWTPs</b>		
San Fernando WWTP	Operating	WASA
Gulf View Development WWTP	Semi-operational	Private
Harmony Hall (eTeck) WWTP	Operating	Under WASA Contract
Marabella Secondary School WWTP	Operating	Private
Palmiste WWTP	Not functional	Private
San Fernando Technical Institute WWTP	Operating	Private
Sunkist WWTP	Not functional	Private
Westpark WWTP	Not functional	Private

Descriptions of these larger systems are presented below, while the locations of all existing sewered areas, WWTPs and lift stations are shown on Figure 3-3.

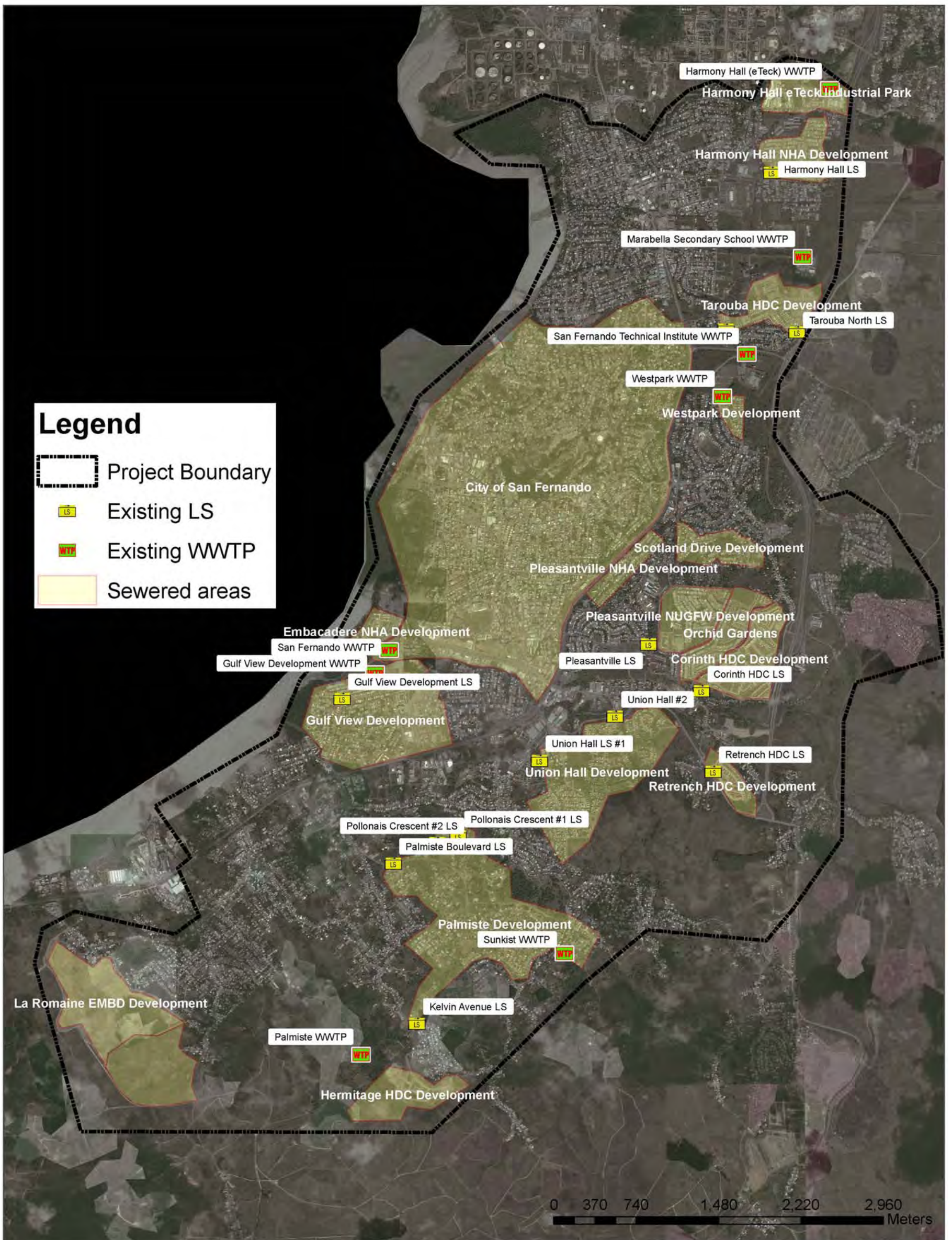


Figure 3-3 Existing Lift Stations and WWTPs, with Current Sewered Areas Displayed



### 3.5.1 San Fernando City Sewerage System

The San Fernando City sewerage system was constructed in the 1960's (Lockjoint Project). The population equivalent (pe) within the existing system is approximately 23,100. Wastewater collected from the area drains into the San Fernando WWTP.

Sections of the trunk sewer that run along the seawall between the San Fernando Yacht Club and King's Wharf are deteriorated and allow infiltration of seawater into the sewer system at high tide (Figure 3-4).



**Figure 3-4 Section of Trunk Sewer Along the Sea Wall Showing Possible Points of Inflow at Pipe Joints**

There are also sections of collapsed or segmented trunk sewer pipes along the Vistabella River (Figure 3-5). These defects are likely caused by soil erosion from the Vistabella River.



**Figure 3-5 Section of Trunk Sewer along Vistabella River Showing Open Joint**



### 3.5.2 Palmiste Development Sewerage System

Most of the wastewater from the Palmiste Development is collected by gravity sewer systems for treatment at the Palmiste WWTP. In four areas lift stations pump wastewater from low lying areas to gravity pipelines. These lift stations are the Palmiste Boulevard LS (servicing mostly the north of the Palmiste Development), Pollonais LS #1 & #2 (servicing the Pollonais Crescent area) and the Kelvin Avenue LS (pumping wastewater from the Palmiste Development main gravity pipeline to the Palmiste WWTP).

### 3.5.3 Union Hall Development Sewerage System

The Union Hall Development is sewered and serviced by two lift stations. Union Hall LS #2 pumps wastewater from gravity sewers mainly in the eastern side of the development to Union Hall LS #1. Union Hall LS #1 collects wastewater on the western side of the development and pumps into the existing San Fernando collection system. Union Hall LS #2 is currently not in operation.

### 3.5.4 Gulf View Development Sewerage System

The Gulf View Development is serviced by the Gulf View Development LS and the Gulf View Development WWTP. The effluent is discharged into the Ciperó River.

## 3.6 Present Wastewater Volume and Strength

AECOM conducted a wastewater sampling programme at the existing San Fernando WWTP during August 2009. The results of the wastewater analyses are presented in Table 3-3. The samples were 24-hour composite samples taken from the inlet pumping station, upstream of any septage addition.

**Table 3-3 Raw Wastewater Concentrations at the Existing San Fernando WWTP (2009)**

Date	Flow <sup>1</sup> (ML/d)	COD (mg/L)	TSS (mg/L)	TKN (mg/L)	NH <sub>3</sub> (mg/L)	TP (mg/L)
04-Aug	9.1	660	510	29	19.0	2.56
05-Aug	8.6	336	220	20	18.1	1.99
11-Aug	4.6	472	200	23	20.3	5.44
13-Aug	9.0	588	370	27	26.5	5.57
14-Aug	10.8	634	312	22	17.9	6.90
17-Aug	5.5	344	310	18	11.8	5.02
18-Aug	4.2	606	275	31	23.5	2.28
19-Aug	10.7	501	240	25	30.0	3.67
20-Aug	6.6	456	280	19	15.7	5.54
21-Aug	6.3	358	340	17	17.4	4.87
24-Aug	6.2	280	174	10	8.4	4.48
Minimum	4.2	280	174	10	8.4	1.21
Maximum	10.8	660	510	31	30	6.90
Arithmetic Average	7.4	476	294	21.9	19.0	4.39
Flow Weighted Average	-	490	302	22.2	19.7	4.43

**Notes:**

- Flow readings were determined from real-time flow data that was recorded throughout the day, with an M-series EMCO UniMAG electromagnetic flow meter.

Based on the sampling results in Table 3-3 the raw wastewater entering the WWTP is relatively strong with respect to COD and TSS, but low to medium strength in terms of total Kjeldahl nitrogen (TKN), ammonia and phosphorus.

The existing San Fernando WWTP receives significant quantities of septage, from a number of sources, as summarized in Table 3-4.

**Table 3-4 Sources of Septage for the Existing San Fernando WWTP**

Sources of Septage
Point Fortin Borough Corporation
Penal/Debe Regional Corporation
Siparia Regional Corporation
Princes Town Regional Corporation
Couva/ Tabaquite/ Talparo Regional Corporation
Shade General Contractors Ltd.
Waste Cleaners & Disposal Co. Ltd.
San Fernando City Corporation
Emergency Septic
B.K. Holdings





To estimate the future quantities of septage that will be received by the San Fernando WWTP, it was assumed that the regional corporations would continue to direct their hauled waste to San Fernando, but private contractors would deliver 50% of their current loads; due to the reduced amount of waste available once the new collection system is installed.

The septage data for 2008 has been analysed and is presented in Table 3-5.

**Table 3-5 Septage Volumes in 2008**

Month	Total Septage Volume (m <sup>3</sup> ) <sup>1</sup>	Estimated Future Septage Volume (m <sup>3</sup> ) <sup>2</sup>
January	1,186	930
February	1,346	1,117
March	1,457	1,183
April	1,703	1,435
May	1,487	1,198
June	1,718	1,362
July	1,911	1,519
August	1,581	1,263
September	1,639	1,384
October	1,753	1,492
November	1,450	1,223
December	440	382
<b>Average</b>	<b>1,472</b>	<b>1,207</b>
<b>Maximum</b>	<b>1,911</b>	<b>1,519</b>

**Notes**

1. Actual volumes for 2008
2. Volumes for 2008 minus 50% of the volume from the private haulers

WASA does not currently monitor the quality of the septage. To evaluate the pollutant loads, typical septage concentrations have been used, as shown in Table 3-6.

**Table 3-6 Typical Septage Concentrations**

Parameter	Suggested Design Value (mg/L) <sup>1</sup>
BOD <sub>5</sub>	7,000
COD	15,000
TSS	15,000
TKN	700
NH <sub>3</sub> -N	150
TP	250

**Notes**

1. US EPA Handbook: Septage Treatment and Disposal (October 1984)

AECOM also collected samples from the Harmony Hall WWTP and lift station in September and October, 2009. The results are provided in Table 3-7.

**Table 3-7 Raw Wastewater Concentrations at Harmony Hall (2009)**

Date	Sample Type	Sample Location	COD (mg/L)	TSS (mg/L)	NH <sub>3</sub> (mg/L)	TP
18-Sept	Composite	WWTP Influent	280	114	26.4	7.74
25-Sept	Grab	WWTP Influent	1,020	500	40.0	-
01-Oct	Grab	WWTP Influent	227	88	13.7	7.47
01-Oct	Grab	Lift Station	397	77	45.9	7.69
02-Oct	Grab	Lift Station	612	219	36.0	9.28
05-Oct	Grab	Lift Station	452	56	50.4	8.23

The composite sample from Harmony Hall is indicative of a weak to medium strength wastewater of domestic origin, although the ammonia concentration is relatively high, and the phosphorus is high. The grab samples indicate that there is likely an industrial discharge occurring, with high COD, ammonia and phosphorus concentrations and a low TSS concentration. This industrial discharge might not be occurring every day, and hence might not have been present on the day of the composite sample. The grab samples were all taken during the period 09:00 am to 10:00 am, and therefore may be measuring an intermittent industrial discharge. It would not be prudent to design a wastewater treatment plant for high strength industrial wastewater; the preferred approach is to control industrial effluents at their source. WASA will need to investigate industrial discharges in the area, and implement stricter industrial effluent control measures.



### 3.7 Design Effluent Flows and Criteria

#### 3.7.1 Design Flows

The average dry weather flow (ADWF) consists of four components:

- Base domestic flow.
- Base commercial component.
- Base industrial component.
- Base infiltration and inflow (I&I).

Peaking factors are applied to the ADWF to estimate the peak dry weather flow (PDWF) and peak wet weather flow (PWWF). PDWF is used for determining the required capacity of the secondary treatment process within the WWTP. Flows in excess of the PDWF will be stored on site until secondary treatment capacity is available. PWWF is used for sizing sewer pipes and lift stations and the overall hydraulic capacity of the WWTP.

Table 3-8 outlines the design flows that will be used for the San Fernando Project.

Design loads have been calculated from information on the loads entering the current San Fernando and Harmony Hall WWTPs, as well as typical design values. (Table 3-9)

**Table 3-8 Summary of Project Design Flows**

Design Parameter	Units	Value
Design Year	-	2035
Equivalent Population	pe	111,600
Unit ADWF	Lpcd	400
Design ADWF	ML/d	45.0
Dry Weather Peaking Factor (PDWF / ADWF)	-	2.0
PDWF	ML/d	90
Peaking Factor (PWWF / ADWF)	-	3.5
PWWF – (WWTP & Collection System)	ML/d	158

**Table 3-9 Average Design Loads for San Fernando WWTP**

Parameter	Unit	Average Value
BOD	mg/L	176
COD	mg/L	386
TSS	mg/L	248
TKN	mg/L	35
TP	mg/L	4.8



### 3.7.2 Design Effluent Criteria

The design effluent criteria are based on treating the wastewater to meet regulations governing reclaimed water as defined in North America. This will provide effluent water that can be used for agricultural and industrial uses instead of discharging this valuable resource to the Ciperó River. Until such time as users of the reclaimed water are identified, the treated effluent from the WWTP will be discharged to the Ciperó River.

Water reuse practices have been adopted in many countries because of increasing demand for water and decreasing supply of traditional sources of water. As part of the San Fernando WWTP design, the option of effluent reuse for non-potable applications has been adopted. Trinidad and Tobago currently do not have standards for water reuse. In the U.S., water reuse and reclamation standards are the responsibility of state agencies. The U.S. Environmental Protection Agency (EPA) published the document entitled “Guidelines for Water Reuse” (2004) to summarize the state guidelines and supporting information.

Treated wastewater may be reused for many applications, such as industrial process and cooling water, agricultural, urban, environmental or recreational uses. The U.S. guidelines are specific to the water application. For the San Fernando WWTP, the agricultural reuse (food crop irrigation) application was selected for comparison because of the proximity of the Picton Estates Mega Farm, a likely destination for the treated effluent. The guidelines are state-specific. Florida was selected for comparison for its similar climate and agricultural production to Trinidad. The guidelines for Agricultural Reuse for Food Crops for Florida are summarized below:

- Treatment: Secondary treatment, filtration and high level disinfection to meet the required Faecal Coliform concentrations.
- Carbonaceous Biochemical Oxygen Demand (CBOD<sub>5</sub>) : <20 mg/L (annual average).
- TSS: <5 mg/L (single sample).
- pH: 6 to 8.5.
- Faecal Coliform: 75% of samples below detection (30 day average) and maximum 25 CFU/100 mL (single sample).

In addition, Florida has the following monitoring requirements for reclaimed water:

- Continuous on-line monitoring of turbidity (as an indicator of treatment plant performance) and chlorine residual.
- Minimum schedule for sampling and testing flow, pH, dissolved oxygen, chlorine residual, TSS, CBOD, nutrients and Faecal Coliforms.
- Monitoring for Giardia and Cryptosporidium once every two years for reclaimed water facilities greater than 3.8 ML/d.

In general, the U.S. EPA Guidelines for Water Reuse for Food Crops (Florida) are more conservative than the EMA Water Pollution Rules.

The reuse standards in Table 3-10 have been adopted as design effluent criteria. These standards exceed those stipulated in the EMA Water Pollution Rules 2001 (as amended) for Inland Surface Water Discharges.

**Table 3-10 San Fernando WWTP Effluent Criteria**

Parameter	EMA Water Pollution Rules 2001 (as amended) for Inland Surface Water Discharge	Design Effluent Criteria
BOD <sub>5</sub> (mg/L)	30	< 20 mg/L (CBOD) <sup>2,4,5</sup>
TSS (mg/L)	50	< 5 <sup>2,4,5</sup>
Dissolved Oxygen (mg/L)	> 4	> 4 <sup>1,3,4,5</sup>
Temperature °C	< 35	< 35 <sup>1,4,5</sup>
Ammonia-Nitrogen (mg/L)	10	< 10 <sup>1,4,5</sup>
Total Nitrogen (mg/L)	-	< 15 <sup>3,4,5</sup>
Total Phosphorus (mg/L)	< 5	< 5 <sup>1,3,4,5</sup>
Faecal Coliform (CFU/100ml)	400	Max: 25/100 mL and 75% samples below detection <sup>2,7,6</sup>
pH	6-9	6 to 8.5 <sup>2,4,5</sup>
Total Residual Chlorine (mg/L)	1	<1 <sup>4,7,5</sup>

**Sources:**

1. Environmental Management Agency (EMA) Water Pollution Rules (Amended 2006), Second Schedule: Permissible Levels of Water Pollutants for Inland Surface Water.
2. U.S. Environmental Protection Agency (EPA) Guidelines for Water Reuse (2004). Table 4-5 Agricultural Reuse – Food Crops for Florida.
3. Water and Sewerage Authority (WASA) Bidding Document for Provision of Consultancy Services for the Integration, Expansion, Upgrade and Refurbishment of the Wastewater Systems in the City of San Fernando and Environs. (April 2007).
4. US Environmental Protection Agency (EPA) Guidelines for Water Reuse (2004). Table 4-13 Suggested Guidelines.

**Notes:**

5. Compliance basis is arithmetic average of daily values for a calendar month.
6. Compliance basis is geometric mean of daily values for a calendar month.
7. The Faecal Coliform and total residual chlorine concentrations for water reuse are included for WASA's future reference, for when it implements water reuse.

### 3.8 Overall Scope of Works

The San Fernando Wastewater project comprises one integrated collection system and one WWTP. The collection system design includes installation of new trunk sewers for conveying wastewater to the new WWTP, new local sewers to capture flow from properties that do not currently have sewer service and combining new and existing sewers into a single integrated collection system. The new WWTP will replace the existing San Fernando WWTP, Harmony Hall WWTP, and several smaller plants previously installed by developers. The new WWTP will be located on the site of the existing San Fernando WWTP, at the western end of Riverside Drive, north of the Ciperó River (Figure 3-6). Land west of the site, that does not currently have equipment constructed on it, will also be utilized.

With the implementation of the project, WASA will become the sole responsible Authority for wastewater treatment and disposal in the Catchment, and will be able to effectively monitor, regulate and control effluent discharged to the environment.



**Figure 3-6 Location of Existing San Fernando WWTP**

### 3.9 Wastewater Treatment Plant Scope of Works

The new San Fernando WWTP will replace all existing plants within the project boundaries (See Section 3.5), and will be located on the site of the existing San Fernando WWTP. Entrance to the plant is currently from Riverside Drive; however, plans are being made to provide an alternate entrance from Gulf View Industrial Park Road.

Construction sequencing will ensure that treatment of the incoming wastewater continues throughout construction.

The plant will be sized to treat the design year 2035 ADWF of 45 ML/d and PDWF of 90 ML/d through secondary and tertiary treatment. The influent pump station and screenings and grit removal

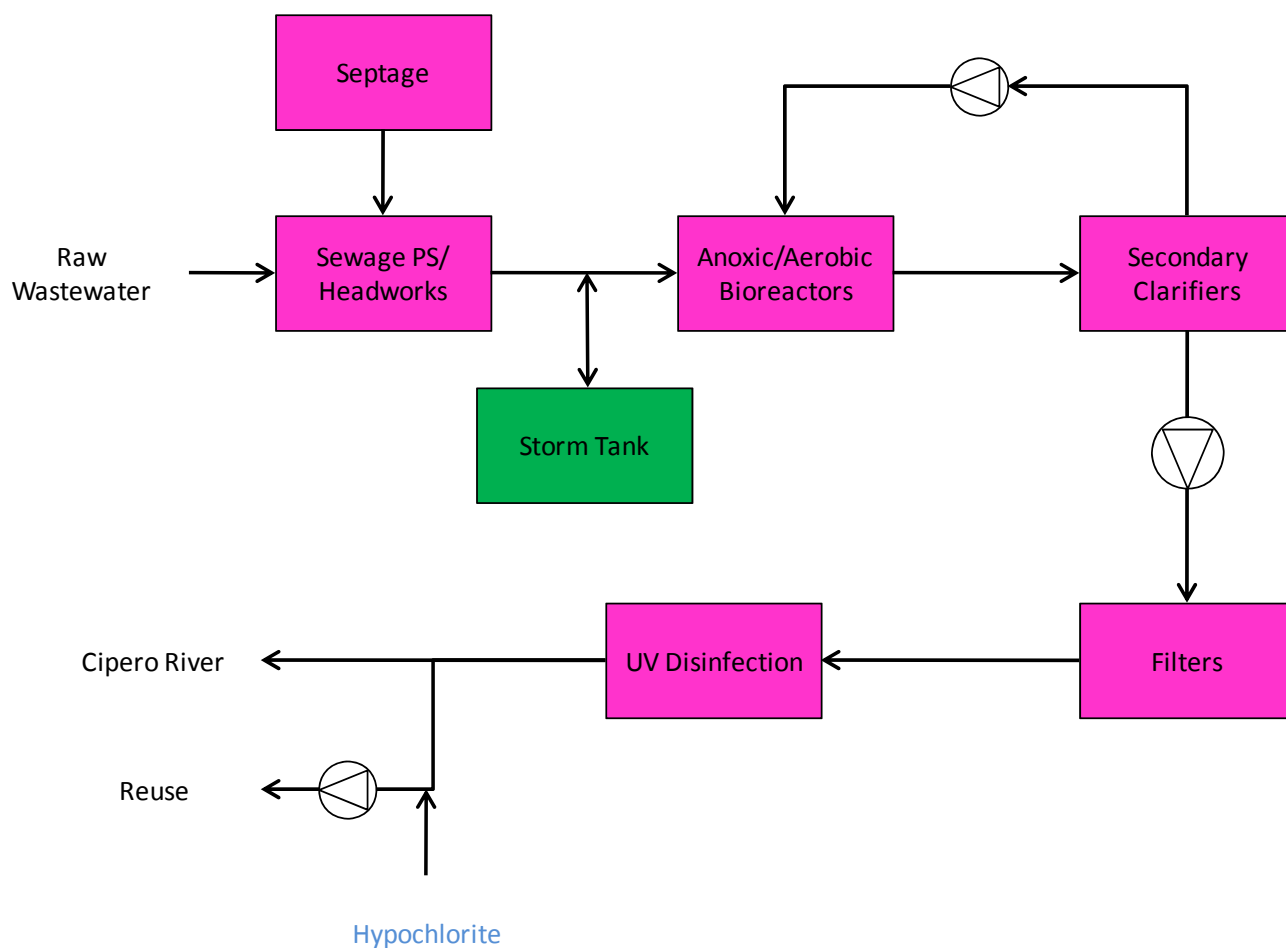


facilities (headworks) will be capable of handling the design PWWF of 158 ML/d. Flows in excess of the PWWF will be diverted to storm water storage facilities until secondary treatment capacity is available. Treated effluent will be discharged to the Ciperó River. Screenings and grit will be washed, dewatered and hauled off site for disposal in a landfill. Waste solids from the activated sludge secondary treatment process will be aerobically digested, dewatered, and hauled off site for disposal.

The treatment scheme for the liquid stream includes the following unit processes:

- Influent pumping
- Septage receiving
- Fine screening
- Grit removal
- Storm water storage
- Activated sludge aeration (Bioreactors)
- Secondary clarification
- Return activated sludge (RAS) pumping
- Filtration
- UV disinfection
- Chlorination (Re-use)

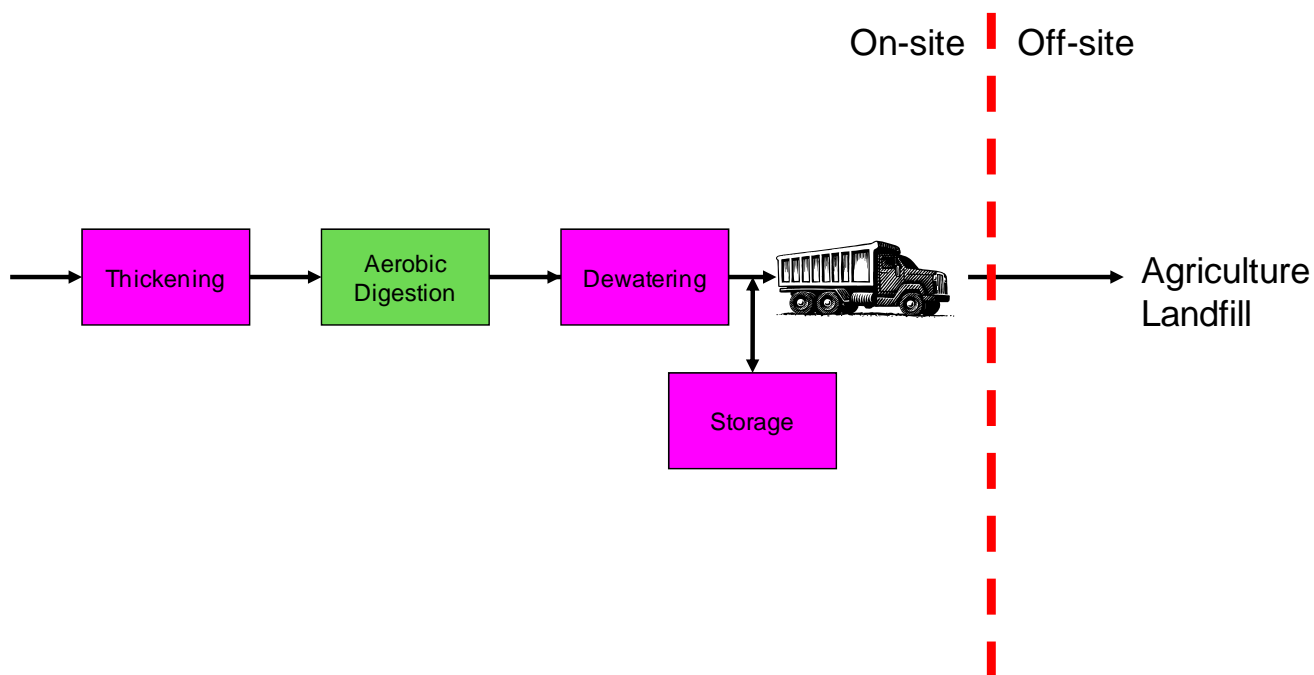
The flow schematic of the process is seen below in Figure 3-7.



**Figure 3-7 WWTP Liquids Flow**

The treatment scheme for waste solids from the activated sludge system involves the waste activated sludge being thickened and then aerobically digested. The digested solids will be dewatered and hauled off site. The existing anaerobic digesters will be converted to aerobic digesters. The dewatering facility will consist of a two-story building with belt filter presses located on the second floor. The lower level will be an open area for loading trucks. The facility will also include polymer storage, mixing and feed equipment. Temporary storage of the dewatered cake will be provided on-site in covered trailers. The dewatered cake will be taken off-site for either agricultural reuse or disposed of in a landfill. A flow schematic of the solids process is seen in Figure 3-8 below.





**Figure 3-8 WWTP Solids Flow Schematic**

Figure 3-9 is a Process Flow Diagram showing both the liquid and solids treatment schemes. The layout of facilities on the site of the existing WWTP is shown on Figure 3-10. Operations and laboratory functions will be housed in an Administration Building. Workshops and offices for mechanical electrical and instrumentation maintenance will be located in a Utility Building.

Three water systems will be provided on the plant site as follows:

- Potable Water (W1) Storage and Pumping Station
- Non-Potable Water (W2) Storage and Pumping Station
- Disinfected Secondary Effluent Water (W3) and Pumping Station

A water balance flow diagram is provided in Figure 3-11.

A full description of each treatment process is provided in the remainder of Section 3.9

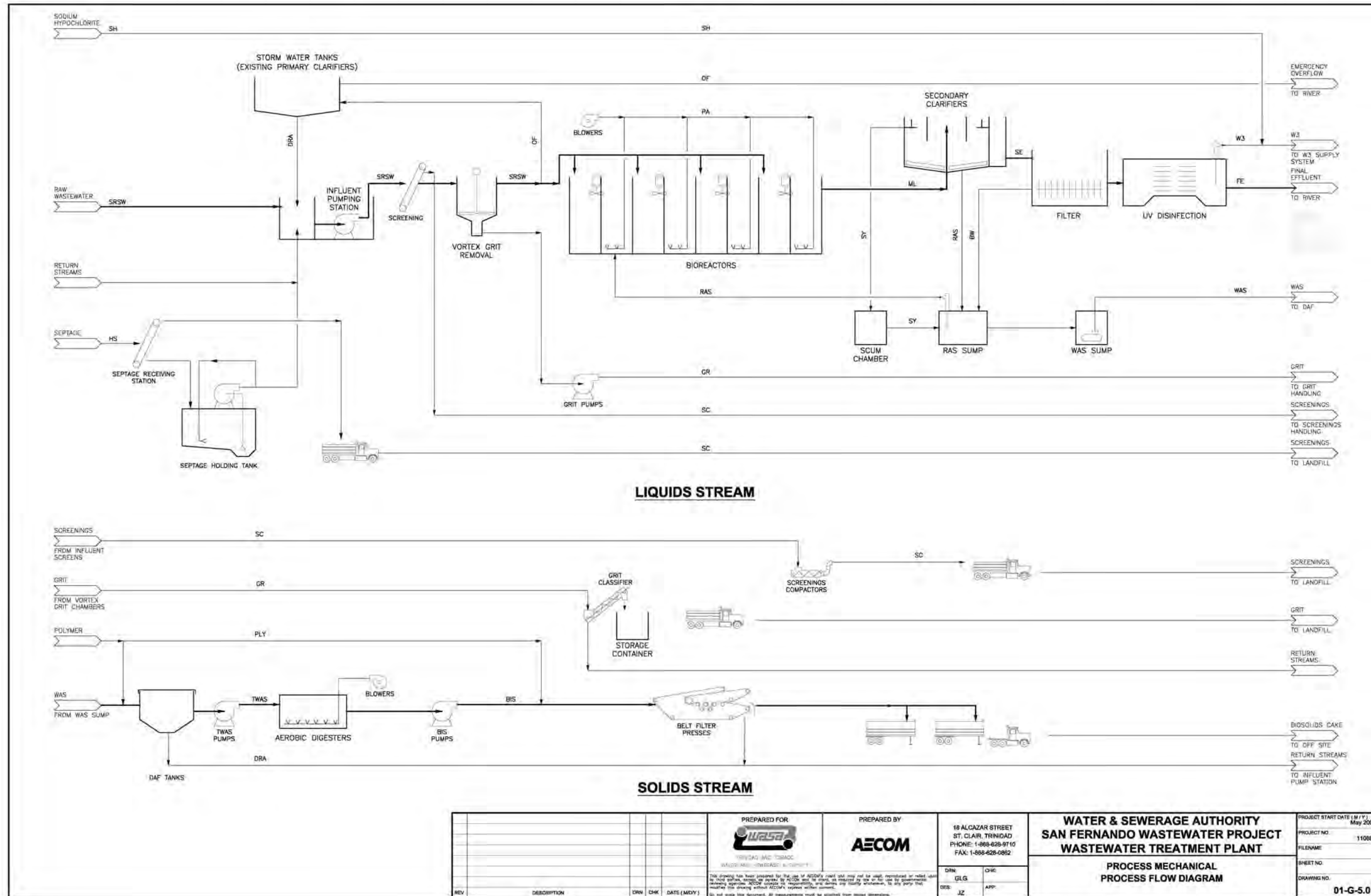


Figure 3-9 WWTP Process Flow Diagram

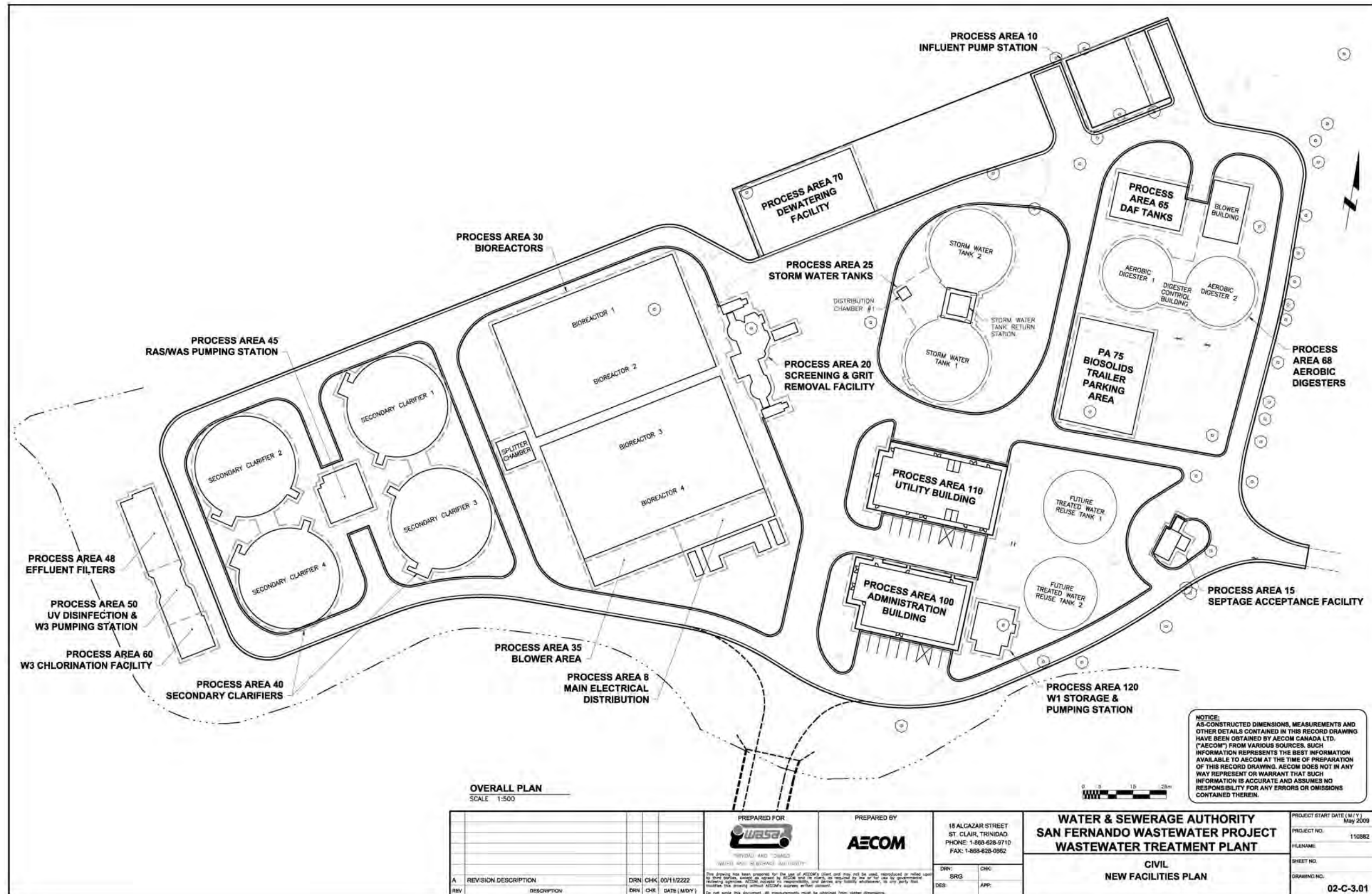


Figure 3-10 WWTP Site Plan

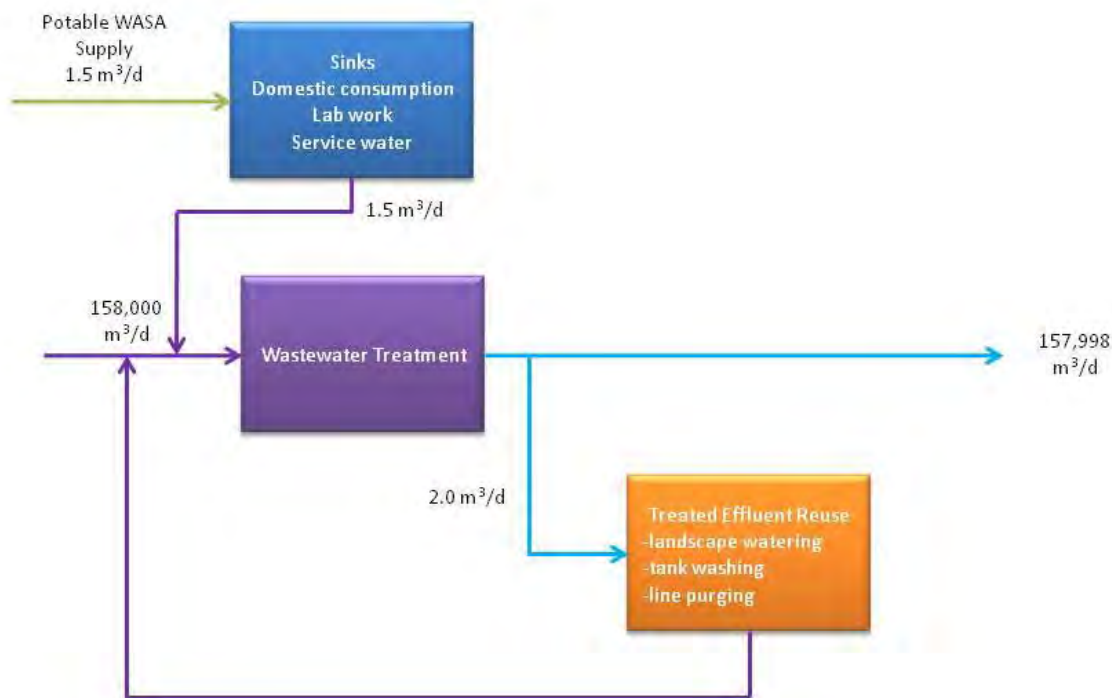


Figure 3-11 Water Balance Flow Schematic for San Fernando WWTP

### 3.9.1 Influent Pump Station

The incoming raw wastewater will enter the plant site from the north and the south and be combined in a junction structure upstream of the influent pumping station. Flow from the junction structure to the influent pumping station will be through two pipes feeding two wet wells. Sluice gates will be provided on each feed pipe and between the two wet well cells. Normal operation will be with all gates open to allow the system to operate as a single wet well. One of the feed gates and the gate between the wet well cells could be closed so maintenance can be performed in one of the wet well cells.

A series of dry pit submersible pumps, mounted in a drywell, pump raw wastewater from the wet wells to the screening system (Figure 3-12).



**Figure 3-12 Dry Pit Submersible Pumps (Chicago Pump)**

A lifting crane is mounted above ground level to raise the pumps from the drywell for maintenance.

Pumps are required to lift the wastewater to an elevation sufficient to allow it to flow by gravity alone through the entire plant to the outfall.

Three pumps are installed for each wet well (total of six pumps) each rated at about 460 L/s. The entire peak flow can be accommodated with two pumps out of service as standby pumps. Flow into a wastewater treatment plant is not constant, but varies with the time of day and season. Therefore, each pump will be equipped with a variable speed drive so that it can match its output as closely as possible to the actual rate of inflow. A level sensor and a controller will maintain a relatively constant water level about the normal water level in the wet well, by controlling the pump speed.

### 3.9.2 Septage Receiving

The septage receiving station will be located on the south east corner of the site, which facilitates the ability for this to be constructed first in the project construction. The new septage receiving station is needed right away so the existing station can be demolished to make space for the new bioreactors. Waste haulers will connect to a pipe that transfers septage into the package septage plant (Figure 3-13). The septage acceptance plant consists of a rock trap and a 6 mm screen.

The screenings, consisting of rags, sticks, and other objects that do not pass through the screens, will be washed and dropped into a dumpster for off-site disposal. Offsite disposal will be in a landfill. The quantity of material removed is dependent on the amount of wastewater received by truck and the characteristics of the septage. The estimated quantity leaving the site would be 1 m<sup>3</sup>/week.

The washed screenings will be contaminated and must be handled and disposed of properly. This is a standard procedure used at WWTPs. Operations personnel will be trained in proper practices so risk is minimized.

The liquids will flow into an underground storage tank located beneath the receiving station. The storage tank will allow for feeding the high strength waste into the treatment plant over time to reduce shock loadings. The liquid will be pumped to the influent pump station.

The design of the septage receiving station is enclosed, with odour suppression equipment. Air vented from the station will pass through an activated carbon filter.



**Figure 3-13 Package Septage Receiving Unit (Courtesy of JWC Environmental)**

### 3.9.3 Fine Screens

Two outdoor influent screens will be mounted above ground level. Each will have a capacity of 158 ML/d. The screens will be band screens with 6 mm openings (Figure 3-14). A wiper removes screenings from the screen and drops the screenings into its dedicated compactor mounted below the discharge point of the screen. Each of the two compactors (Figure 3-15) reduces the moisture content of the material, raising the solids concentration from approximately 15% to 40%. The compactor consists of a screw conveyor that drives the material into a converging cone section. As the material is 'squeezed' into the cone, water is ejected and is drained to the influent channel. Compacted screenings discharge into a dumpster. The dewatered screenings are hauled off-site for disposal. The quantity of material removed is dependent on the wastewater characteristics.

Compressed air will be provided to supply air to a coarse bubble aeration system in the channels ahead of the screens to minimize settlement of grit under low flow conditions.



**Figure 3-14 Band – Type Fine Screen (Courtesy of JWC Environmental)**



**Figure 3-15 Screenings Compactor (Courtesy of Huber Technology)**

### 3.9.4 Grit Removal

The screened wastewater will be conveyed in channels to the grit removal area. Grit will be removed by two mechanically induced vortex grit removal chambers. These chambers are designed to remove greater than 80% of the silt, sand, and other inert material greater than 0.25 mm in size. The de-gritted effluent continues to the bioreactor, while the collected grit is dewatered in a cyclone classifier to approximately 75% solids content and stored for offsite disposal. Three facilities associated with grit removal are as follows:



- Vortex Grit Removal Chambers – Vortex grit removal chambers exploit the difference in density between inorganic (grit) and organic solids to separate the two materials and preferentially remove the grit from the process stream.
- Grit Pump – Grit slurry is removed from the bottom of each grit chamber by a recessed impeller solids-handling centrifugal pump.
- Grit classifier – Grit slurry is pumped from the vortex chambers to two grit classifier and dewatering systems. Each system consists of cyclones (one per connected pump), a clarifier tanks, and dewatering screw conveyor.

### 3.9.5 Flow Measurement and Wet Weather Storage

The flow from the grit tanks will be directed to a distribution chamber, where the wastewater will be directed to the bioreactors and to the stormwater storage tanks if the flow exceeds the capacity of the secondary treatment system. The distribution chamber will use adjustable weirs to allow the flow split to be altered when a bioreactor is taken out of service.

Signals from magnetic flow meters in the feed pipes to the bioreactor will be used to modulate an actuated gate that controls flow to the storm water tank. When the total flow to the plant exceeds 90 ML/d, the actuated weir gate will modulate to limit the flow to the bioreactors to 90 ML/d. Bypassed flows will be directed to storm water storage tanks.

### 3.9.6 Storm Water Storage

The storm water storage facility will provide storage during extreme wet weather events. Once the storm event has subsided, the contents of the storage facility would be gradually returned to the headworks for treatment. Septic conditions should not arise, as provisions will be made for manual flushing of the Storm Water Tank once it has been drained.

The two 23m diameter existing primary clarifiers (Figure 3-16) will be converted to storm water tanks. With a sidewall depth of 2.75 m and a floor slope of 1:12, the two clarifiers provide a total volume of 2512 m<sup>3</sup>, which corresponds to 50 minutes of storage during the peak instantaneous flow to the WWTP of 158 ML/d. This storage volume is expected to contain all storms considering that the majority of the collection system will be new and I&I should be minimized.





**Figure 3-16 Recently Refurbished Primary Clarifiers at San Fernando WWTP**

### 3.9.7 Bioreactors

Biochemical reactions in the bioreactor convert the organics in the wastewater to respiration products ( $\text{CO}_2$  and  $\text{H}_2\text{O}$ ) and cellular material. The residual organic levels following solids separation are sufficiently low to render the treated wastewater acceptable for discharge. In addition, nitrogen concentrations are reduced by nitrification-denitrification. Nitrification is the oxidation of ammonia to nitrate, and denitrification is the conversion of nitrate to nitrogen gas.

The bioreactor structure comprises four equally sized parallel aeration systems. With a total volume of  $44,100 \text{ m}^3$ , the hydraulic retention time (HRT) at the ADWF is 10 days. System solids retention time (SRT) will be controlled at a minimum of 10 days. A portion of each bioreactor will be mixed and not aerated to promote denitrification reactions. Simultaneous nitrification-denitrification (SND) in zones aerated by fine bubble diffusers (Figure 3-17) will reduce effluent nitrate concentrations. Mixed liquor recycle pumping is provided to increase the level of denitrification and meet the total nitrogen limit.



**Figure 3-17 Fine Bubble Aeration Bioreactor**

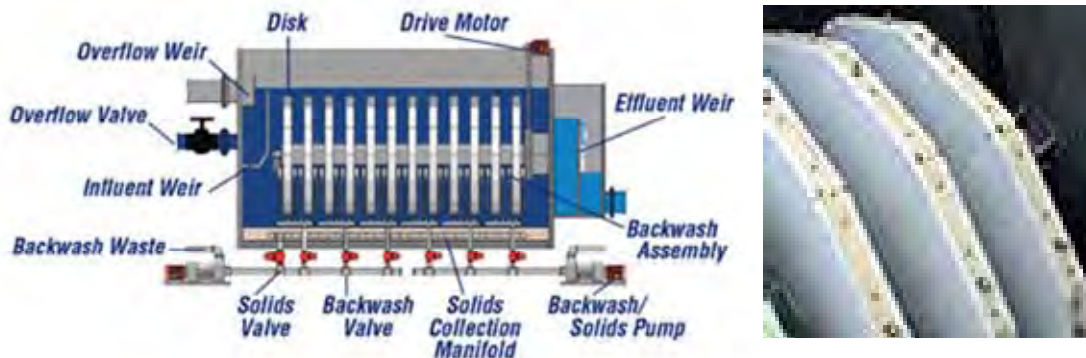
### 3.9.8 Secondary Clarifiers

Mixed liquor from the bioreactor is divided in a splitter box and conveyed to four secondary clarifiers. The clarifiers separate the mixed liquor into RAS, which settles to the clarifier floor and is returned to the bioreactor, and secondary effluent, which proceeds to filtration, disinfection and final discharge.

Each secondary clarifier is a circular reinforced concrete tank. They are each equipped with a full radius suction header mechanism that removes the settled sludge to a common wet well for withdrawal by the return activated sludge pumps. Each of the four clarifiers is 29 m in diameter, with a 6.0 m side water depth (SWD).

### 3.9.9 Filtration

To produce an effluent with a low TSS concentration suitable for reuse, a filtration process is required. Disc filters will be provided. In this process the water passes through a series of rotating cloth-covered or mesh-covered discs (Figure 3-18) into a central collection header. The filtered effluent exits the central header via a chamber equipped with an overflow. Backwashing is conducted in-situ while the discs are rotating. A series of suction shoes are used to vacuum the solids off the surface of the disc.



**Figure 3-18 Cloth Media Filter (Courtesy of Aqua-Aerobic Systems)**

Figure 3-19 shows an example of a cloth media filtration plant. For the San Fernando WWTP, five packaged filtration units will be installed. The system is sized so that the PWWF can be handled by only four units.



**Figure 3-19 Cloth Media Filtration Plant (Courtesy of Aqua-Aerobic Systems)**

### 3.9.10 UV Disinfection

Disinfection reduces levels of pathogens in the final effluent to meet discharge regulations stipulated by the Environmental Management Authority of less than 400 Faecal Coliform/100 mL.

The recommended disinfection system consists of a low pressure, high intensity ultraviolet (UV) irradiation system. The UV system will be sized to disinfect up to 90 ML/d (peak secondary treatment flow) to less than 25 N/100 mL Faecal Coliform.

Secondary effluent is split between two UV channels. Manual slide gates at the head of each channel can be used to isolate a channel when it is not required or when maintenance needs to be performed. Each channel is equipped with an array of UV lamps, arranged parallel to the flow. A weir downstream



maintains constant lamp submergence, regardless of flow. If the level drops so that the lamps are exposed, the system shuts off to prevent damage to the lamps.

The disinfected secondary effluent flow discharges from the UV facility through a channel that enters a parshall flume. This flume measures the flow out of the plant, maintains upstream water levels, and sends a signal to the UV system controls. The flume discharges into a chamber, which directs flow into an outfall pipe that conveys the treated effluent to the Cipero River. A connection is also provided for diverting the effluent water to a future reclaimed water pumping station.

### 3.9.11 Secondary Sludge Pumping

#### 3.9.11.1 Return Activated Sludge (RAS) Pumps

Return activated sludge (RAS) will be withdrawn from each clarifier via a magnetic flow meter and weir gate. The elevation of the weir gate is automatically adjusted to vary the RAS flow based on the signal from the flow meter. The overflow from each weir gate discharges into a common RAS well. A series of pumps transfer the RAS from the wet well to inlet end of the bioreactors. This arrangement for RAS pumping means that RAS pumping capacity is independent of the number of clarifiers in operation. If one clarifier is taken out of service, there is no reduction in the number of available RAS pumps.

Three RAS pumps will be provided (two on duty, and one standby). The pumps convey the RAS, via a common header, to the RAS splitter box. This box directs the RAS flow to the four bioreactor modules.

#### 3.9.11.2 Waste Activated Sludge Pumps

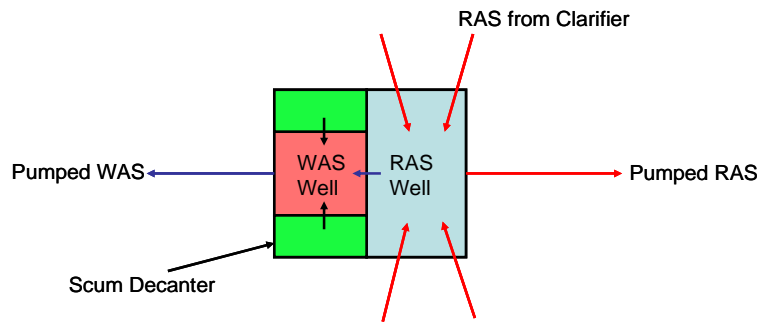
Waste activated sludge (WAS) is removed via a separate WAS wet well, and pumping system. A penetration between the WAS wet well and the RAS wet well allows RAS to flow into the WAS tank when the WAS pumps are running. Scum collected from the surface of the clarifiers is also directed to the WAS wet well. The WAS and scum in the WAS wet well are kept in suspension by mixers.

WAS and scum will be conveyed from the WAS wet well to the dissolved air flotation thickeners using three (two duty, one standby) interconnected variable speed WAS pumps.

#### 3.9.11.3 Scum Decanters

Each pair of secondary clarifiers will be served by one scum decanter. The WAS wet well will be located between the two decanter boxes. The scum decanter consists of a concrete box equipped with a manually operated weir gate, and an adjustable telescopic valve. Scum will be manually removed from the decanters by lowering of the weir gates. The subnatant (water) from the decanters will be removed via the telescopic valve. Each revolution of the secondary clarifier mechanism results in a slug of water and scum being conveyed to the decanter. The scum floats to the surface, and the subnatant overflows via the standpipe to the plant drain piping that discharges to the wet well of the plant influent pumping station.

A schematic of the WAS, RAS and scum decanter system is provided in Figure 3-20.



**Figure 3-20 WAS, RAS, and Scum Decanter Schematic**

### 3.9.12 Sludge Thickening

It is necessary to thicken the WAS to provide sufficient retention time in the aerobic digesters. Dissolved air flotation (DAF) will be used for sludge thickening. DAF introduces fine air bubbles to the sludge, which attach to the solids and cause them to rise to the surface where they form a thickened froth, which is collected by a skimming mechanism. This process does not require polymer, and is typically operated unmanned during the night and at weekends.

The main components of a DAF thickener system are the pressurization system and the DAF tank (Figure 3-21). The pressurization system includes a recycle pressurization pump, an air compressor, and a backpressure control valve. The DAF tank is equipped with a surface skimmer. A bottom sludge removal mechanism will not be required because the sludge source is a suspended growth secondary treatment system.

For the San Fernando WWTP, two pre-fabricated stainless steel DAF tanks will be provided (each 3.5 m wide by 20 m long). Under normal operating conditions, both tanks will operate without polymer addition, and will thicken the WAS to about 3% dry solids. The DAF tanks will be equipped with covers and will be located outdoors adjacent to the aerobic digesters.



**Figure 3-21 Stainless Steel DAF Tank**

If one of the DAF tanks is out of service for maintenance, or if there is an unexpected temporary lapse in performance, polymer can be added to improve the capture rate thereby increasing the solids loading capacity and stabilizing the DAF operation significantly.

Thickened WAS will be pumped by progressive cavity pump to the aerobic digesters.

### 3.9.13 Aerobic Digestion

The two existing anaerobic digesters will be converted into aerobic digesters. Each digester has a volumetric capacity of 2400 m<sup>3</sup>, to give a total capacity of 4800 m<sup>3</sup>.

With thickened WAS at a solids concentration of 3%, the retention in the digesters will be 15 days, in accordance with WASA Guidelines. With testing, USEPA Guidelines to meet a Class B Sludge are expected to be met.

The aerobic digesters will be aerated by coarse bubble aeration devices. Air will be supplied by a series of fixed speed positive displacement blowers in acoustic enclosures. The air will be cycled on and off to provide anoxic conditions for denitrification of nitrate generated during the digestion process. Mixers will be used to mix the digesters during the anoxic stages.

Digested solids (biosolids) will be pumped to the dewatering system.

### 3.9.14 Sludge Dewatering and Loadout

The biosolids will be dewatered before removal from the WWTP site to minimize truck traffic through the surrounding neighbourhoods. To minimize footprint and complexity, a two storey building will be provided, with the dewatering equipment located on the upper floor. Cake from the dewatering equipment would drop down a chute into truck trailers parked at grade level. During change-out of the



trailers, the dewatering equipment will need to be stopped. With 20 tonne capacity trailers, it is expected that approximately 25 trailers would be required per week.

The dewatered cake will be hauled off-site for agricultural reuse, or to landfill. A paved trailer storage area will be provided that will allow WASA to temporarily park biosolids-laden trailers covered with tarps, in the event of an emergency.

Thickened and digested biosolids will be pumped from the digesters to three belt filter presses (BFP) (2 on duty, 1 standby) (Figure 3-22). In the belt filter press the solids content is increased from approximately 2% solids to between 10 to 15% solids. The belt filter presses are three-belt units consisting of one gravity belt followed by two pressure belts. The gravity and pressure sections are operated independently to optimize the thickening and dewatering functions within a single unit. The gravity section thickens the liquid biosolids by removing a majority of the water. The thickened biosolids then feed the pressure section where the two belts are routed through a serpentine path between a series of rollers. As the sludge travels along the dewatering path, pressure is increased, expelling water from the material. On their return travel, the three belts are washed by a flow of clean water. All liquid waste from the belt filter press will travel by gravity to the influent pumping station. From the influent pumping station, it will be treated in the WWTP.



**Figure 3-22 Three Belt Filter Press (courtesy of Andritz)**

It will be necessary to store solids during night time hours and over weekends when the dewatering equipment is not operating. Three options will be available to plant operations:

- Draw down the digesters during weekday operations of the BFPs to make room for solids wasted at night and on weekends.
- Suspend solids wasting at night and on weekends thereby storing the solids in the bioreactors.
- Approximately one day of storage for dewatered biosolids will be provided. The storage will be in covered trailers parked in a paved area on site.



### 3.9.15 Wastewater Reuse Option

The design of the WWTP incorporates tertiary treatment processes for effluent reuse and has allowances on the site layout for future works related to pumping the reuse water to future customers.

The filtered and UV disinfected water will be directed to a chlorination system that feeds sodium hypochlorite solution. The chlorinated effluent will flow by gravity to one or both of the existing secondary clarifiers. These existing secondary clarifiers would be used as chlorine contact chambers, and will also act as a wet well for the future reuse transfer pumps. These pumps will transfer the water to the end-user.

The design of the WWTP includes space in the hypochlorite room for the addition of hypochlorite tanks for effluent reuse disinfection. The design also includes a 750mm diameter pipeline from the UV facility to the future chlorine contact chamber and pumping facility.

### 3.9.16 Chlorination Facility

#### 3.9.16.1 Plant Re-use Water

A small portion of the effluent will be recycled within the plant for various purposes such as landscape watering, tank flushing, and line purging. This plant reuse water will be chlorinated for the protection of the operators, through sodium hypochlorite dosing. Sodium hypochlorite has been chosen due to its low risk on personnel injury or environmental damage. The hypochlorite solution will be delivered in 1m<sup>3</sup> totes. A maximum of four totes will be on site at once. These totes will be stored so that in the event of spills, the liquid will be contained and not released to the environment. All spills will be flushed into the wastewater drainage system for treatment through the WWTP. The MSDS for sodium hypochlorite has been included in **Appendix C.1**.

#### 3.9.16.2 Reuse Water Option

The use of the treated effluent for reuse would require the dosing with sodium hypochlorite; however, the amount is unknown at this time due to the unknowns with the amount of water to be used for reuse purposes. The sodium hypochlorite would be stored in the same location as the totes used for plant reuse water. In the event of spills, the liquid will be contained and not released to the environment. All spills will be flushed into the wastewater drainage system for treatment through the WWTP.

### 3.9.17 Polymer Addition

Polymer addition will be required for the belt filter press dewatering operation, and occasionally for the DAF system during maintenance, or temporary lapse in performance. The actual polymer will be selected when testing is done during plant commissioning; however, a MSDS for the polymer typically used is enclosed in **Appendix C.2**. Polymer will be delivered in bags or barrels and will be stored on pallets in a dry storage room. All proper MSDS requirements will be followed for storage and handling.

### 3.9.18 Utility Requirements

As the new San Fernando WWTP is to be constructed on the site of the existing WWTP, most utilities are already established and installed. Additional electrical feeder lines from T&TEC will be required to meet the increased load for the larger WWTP capacity. Redundant feeder lines will be provided from





two substations for maximum reliability. Standby generators will also be provided to power the entire plant in the event that T&TEC power is lost.

### 3.9.19 Design Summary

Table 3-11 summarizes the design criteria, unit process capabilities, and equipment details for the new San Fernando WWTP.

**Table 3-11 San Fernando Wastewater Treatment Plant Design Data**

Item	Units	Value
<b>Raw Wastewater Characteristics</b>		
Flow		
ADWF	ML/d	45
AWWF	ML/d	90
PWWF	ML/d	158
Total Loads		
BOD		
Average	kg/d	7,900
Maximum month	kg/d	9,240
COD		
Average	kg/d	17,360
Maximum month	kg/d	20,310
TSS		
Average	kg/d	11,150
Maximum month	kg/d	14,380
TN		
Average	kg/d	1,560
Maximum month	kg/d	1,750
TP		
Average	kg/d	215
Maximum month	kg/d	250
<b>Final Effluent – Reuse</b>		
Monthly Arithmetic Average		
COD	mg/L	250
BOD	mg/L	20
TSS	mg/L	5
Total Oil & Grease	mg/L	10
TN	mg/L	15



**Table 3-11 San Fernando Wastewater Treatment Plant Design Data (continued)**

Item	Units	Value
TP	mg/L	5
DO	mg/L	>4
pH		6 to 8.5
Residual Chlorine	mg/L	>1.0
Monthly Geometric Mean	mg/L	20
Faecal Coliforms	N/100 mL	25
<b>Raw Wastewater Pumps</b>		
Number		6
Capacity	L/s	460
Head	m	23
Power	kW	150
<b>Septage Acceptance Plant</b>		
Number		1
Capacity	L/s	15
Screen Size	mm	6
Power	kW	1.5
<b>Septage Holding Tank</b>		
Width	m	4.1
Length	m	7.9
Depth	m	2.8
Volume	m <sup>3</sup>	94
<b>Mixing/ Transfer Pumps</b>		
Number		2
Capacity	L/s	6
Power		7.5
<b>Screening</b>		
Number		2
Opening Size	mm	6
Capacity per screen	ML/d	158
Dimensions		
Width, m	m	0.94
SWD, m	m	3.80
Screenings Quantities (wet)		
Average	kg/d	3,240
Maximum	kg/d	32,400



**Table 3-11 San Fernando Wastewater Treatment Plant Design Data (continued)**

Item	Units	Value
<b>Compactors</b>		
Number		2
Capacity	m <sup>3</sup> /hr	0.5
<b>Compacted Screenings Quantities (wet)</b>		
Average	kg/d	1,215
Maximum	kg/d	12,150
<b>Grit Removal</b>		
Type		Vortex
Number		2
Capacity	ML/d	80
<b>Dimensions</b>		
Diameter	m	5.48
Depth	m	8.10
<b>Grit Pumps</b>		
Number		2
Capacity per pump	m <sup>3</sup> /h	57
Power	kW	6
<b>Classifiers</b>		
Number		2
Capacity	m <sup>3</sup> /h	0.3
<b>Dewatered Grit Quantities</b>		
<b>Dry Solids</b>		
Average	Tonnes/d	2
Maximum	Tonnes/d	20
<b>Volume</b>		
Average	m <sup>3</sup> /d	1.6
Maximum	m <sup>3</sup> /d	16
<b>Storm Water Storage Tanks</b>		
Peak Flow	ML/d	68
Peak Overflow Rate (OFR)	m <sup>3</sup> /m <sup>2</sup> /d	166
Number		2
<b>Dimensions</b>		
Diameter	m	22.9
SWD	m	3.90
Volume	m <sup>3</sup>	1600



**Table 3-11 San Fernando Wastewater Treatment Plant Design Data (continued)**

Item	Units	Value
<b>Bioreactors</b>		
Peak Flow	ML/d	90
Basic Design Parameters <sup>1</sup>		
SRT	d	10
HRT	d	13
MLSS – Aerobic Zone 1	mg/L	6,100
MLSS – Aerobic Zone 2	mg/L	5,000
MLSS – Aerobic Zone 3	mg/L	4,200
MLSS – Aerobic Zone 4	mg/L	3,200
Number of Bioreactors		4
Volume per Bioreactor	m <sup>3</sup>	5,970
Pre- Anoxic Cells		
Number per Bioreactor		1
Volume per cell	m <sup>3</sup>	70
Anoxic Cells		
Number per Bioreactor		3
Volume per cell	m <sup>3</sup>	543
Aerobic Cells		
Number per Bioreactor		4
Volume – Aerobic Zone 1	m <sup>3</sup>	1,016
Volume – Aerobic Zone 2	m <sup>3</sup>	1,085
Volume – Aerobic Zone 3	m <sup>3</sup>	1,085
Volume – Aerobic Zone 4	m <sup>3</sup>	1,085
Dimensions		
SWD	m	7
<b>Anoxic Cell Mixers</b>		
Total number of Mixers		16
Total number of Pre-anoxic Mixers		4
Total number of Anoxic Mixers		12
Number of Mixers per Anoxic Zone		1
Power Per Pre-anoxic Mixer		0.56
Power Per Anoxic Mixer	kW	2.2
<b>Diffused Aeration</b>		
Type		Fine Bubble
Alpha Factor		
Aeration Zone 1		0.63
Aeration Zone 2		0.68



**Table 3-11 San Fernando Wastewater Treatment Plant Design Data (continued)**

Item	Units	Value
Aeration Zone 3		0.72
Aeration Zone 4		0.78
Field Oxygen Demand		
Average per basin	kgO <sub>2</sub> /d	4,560
Maximum per basin	kgO <sub>2</sub> /d	6,080
Aeration Zone 1		
Average	kgO <sub>2</sub> /d	1,440
Maximum	kgO <sub>2</sub> /d	1,920
Aeration Zone 2		
Average	kgO <sub>2</sub> /d	1,080
Maximum	kgO <sub>2</sub> /d	1,440
Aeration Zone 3		
Average	kgO <sub>2</sub> /d	1,800
Maximum	kgO <sub>2</sub> /d	2,400
Aeration Zone 4		
Average	kgO <sub>2</sub> /d	960
Maximum	kgO <sub>2</sub> /d	1,280
Standard Oxygen Demand		
Average per basin	kgO <sub>2</sub> /d	8,856
Maximum per basin	kgO <sub>2</sub> /d	11,832
Aeration Zone 1		
Average	kgO <sub>2</sub> /d	3,072
Maximum	kgO <sub>2</sub> /d	4,104
Aeration Zone 2		
Average	kgO <sub>2</sub> /d	2,136
Maximum	kgO <sub>2</sub> /d	2,856
Aeration Zone 3		
Average	kgO <sub>2</sub> /d	1,800
Maximum	kgO <sub>2</sub> /d	2,400
Aeration Zone 4		
Average	kgO <sub>2</sub> /d	1,848
Maximum	kgO <sub>2</sub> /d	2,472
<b>Aeration Blowers</b>		
Type		Pos. Disp.
Number		6
Capacity	Nm <sup>3</sup> /min	47
Discharge Pressure	kPa	90
Motor Size	kW	110



**Table 3-11 San Fernando Wastewater Treatment Plant Design Data (continued)**

Item	Units	Value
<b>Secondary Clarifiers</b>		
Overflow Rate (OFR)		
Average	m/h	0.7
Maximum	m/h	1.4
Solids Loading Rate (SLR <sub>pk</sub> )		
Average	kg/m <sup>2</sup> /h	3.5
Maximum	kg/m <sup>2</sup> /h	5.4
Number		4
Dimensions		
Diameter	m	29
SWD	m	6
<b>Filtration</b>		
Type		Cloth Discs
Number of filter cells		5
Number of discs per filter cell		12
Filter Area per disc	m <sup>2</sup>	5
<b>UV Disinfection</b>		
Peak process capacity	ML/d	90
Peak hydraulic capacity	ML/d	90
No of channels		2
Banks per channel		1
Lamps per bank		208
UV reduction equivalent dosage	mWs/cm <sup>2</sup>	35
UV transmittance	%	60
Power	kW	52
<b>Return Activated Sludge (RAS) Pumps</b>		
Number		3
Capacity	L/s	350
TDH	m	15
Power	kW	55



**Table 3-11 San Fernando Wastewater Treatment Plant Design Data (continued)**

Item	Units	Value
<b>Waste Activated Sludge (WAS) Pumps</b>		
Number		2
Capacity	L/s	17.4
TDH	m	17.6
Power	kW	11
<b>Waste Sludge Characteristics</b>		
Solid Loads		
Average	kg TSS/d	8,850
Maximum	kg TSS/d	11,050
Volatile Suspended Solids		
Average	kg VSS/d	4,150
Maximum	kg VSS/d	4,980
Concentration	%	0.5 to 1.0
Maximum Flow	m <sup>3</sup> /d	1,500
<b>Dissolved Air Flotation Thickeners</b>		
Number		2
Width	m	4.3
Length	m	14.6
Depth	m	3.4
Maximum Flow	ML/d	1.5
Peak solids loading	kg/hr.m <sup>2</sup>	4.39
TWAS Concentration	%	2-4
<b>Aerobic Digesters</b>		
Number		2
Volume, each digester	m <sup>3</sup>	2,000
Solids Concentration	%	3
Solids Loading after digestion		
Average	kg TSS/d	7,670
Maximum	kg TSS/d	9,700
Volatile Suspended Solids		
Average	kg VSS/d	3,120
Maximum	kg VSS/d	3,790
Alpha Factor		0.15
Retention Time	d	15
OTR	kgO <sub>2</sub> /d	2,326
SOTR	kgO <sub>2</sub> /d	8,971
Specific O <sub>2</sub> Uptake Rate – SOUR	mg/hr/gTSS	1.5



**Table 3-11 San Fernando Wastewater Treatment Plant Design Data (continued)**

Item	Units	Value
<b>Digester Mixers</b>		
Number per tank		1
Motor size	kW	30
<b>Digester Blowers</b>		
Type		Pos. Disp.
Number		6
Capacity	Nm <sup>3</sup> /min	70
Discharge Pressure	kPa	90
Motor size	kW	187.5
<b>Belt Filter Presses</b>		
Total Number		3
Duty		2
Standby		1
Weekly operation	d/week	5
Daily operation	h/d	8
<b>Solids loads</b>		
Average	kg/d	10,738
Maximum	kg/d	13,580
<b>Solids concentration</b>		
Inlet	%	2-4
Outlet	%	15-20
Belt width each unit	m	3
Solids loading	kg/m/h	300
Hydraulic loading	m <sup>3</sup> /m/h	8
Minimum solids capture	%	95
<b>Belt Drives</b>		
Number of drives per unit		3
Power	kW	9.3
<b>Belt washwater</b>		
Flow per unit	L/s	2.5
Pressure	kPa	800
<b>High Pressure Booster Pump</b>		
Number of pumps		3
Flow per unit	L/s	7.5
Head	m	82
Power	kW	5.6





**Table 3-11 San Fernando Wastewater Treatment Plant Design Data (continued)**

Item	Units	Value
<b>Compressed Air</b>		
Flow per unit	Nm <sup>3</sup> /h	1
Pressure	kPa	1,000
<b>Compressor</b>		
Number of compressors		2
Capacity	Nm <sup>3</sup> /h	10
Pressure	kPa	1,000
Power	kW	2.2
<b>Polymer System</b>		
Number of make-up systems		1
Number of storage tanks		1
<b>Polymer dosage</b>		
Average	kg/t	10
Maximum	kg/t	20
<b>Hourly polymer load</b>		
Average	kg/h	13
Maximum	kg/h	34
<b>Dry polymer Loader Requirement</b>		
Average	kg/week	540
Weekly	kg/week	1,360
<b>Polymer concentration</b>		
After make-up	% w/w	0.5
After addition of carrier water	% w/w	0.1
Volume of mixing tank (each)	L	7,000
Volume of storage tank	L	14,000
Aging time in mixing tank at 0.5 % w/w	min	60
<b>Polymer Dosing Pumps</b>		
Number of pumps		5
Capacity (each)	L/min	60
Design head	m	50
Power	kW	0.75
Dry Polymer Screw Feeder Power	kW	0.18
Dry Polymer Blower Power	kW	1.86
Mixer Power	kW	2.20



**Table 3-11 San Fernando Wastewater Treatment Plant Design Data (continued)**

Item	Units	Value
<b>W1 Water Supply Pumps</b>		
Number		3
Capacity	m <sup>3</sup> /h	12
TDH	m	50
Power	kW	5.5
<b>Storage Reservoir</b>		
	m <sup>3</sup>	450
<b>W3 Water Supply Pumps</b>		
Number		2
Capacity	m <sup>3</sup> /h	110
TDH	m	80
Power	kW	37.5
<b>Hypochlorite Disinfection of W3</b>		
Hypochlorite Concentration	%	8.3
Dosage	mg/l	3.3
Number of Pumps		2
Capacity	L/hr	5.1
Power	kW	0.75
<b>Onsite Storage</b>		
Number		4
Volume per tote	m <sup>3</sup>	1

Note HRT – Hydraulic retention time  
 OFR – Overflow rate  
 SLR – Solids loading rate  
 SOUR – Specific oxygen uptake rate  
 SWD – Sidewall water depth

MLSS – Mixed liquor suspended solids  
 OTR – Oxygen transfer rate  
 SOTR – Standard oxygen transfer rate  
 SRT – Solids retention time  
 TDH – Total dynamic head

### 3.10 Collection System Scope of Works

#### 3.10.1 Sewer Piping Network

The proposed wastewater collection system will consist of pipes of various sizes including trunk sewers, local (district) sewers, terminal sewers, service connections and forcemains. Trunk sewers convey PWWF from a subcatchment to another trunk sewer or to the WWTP. Typically, sewers that serve a population of approximately 3,000 pe or exceed a flow of 40 L/s, are designated as trunk sewers. Local or district sewers feed the trunk sewers and theoretically have a peak flow capacity of less than 40 L/s including a nominal allowance for infiltration. Terminal sewers are at the upstream end of the sewer system where the line begins. Service connections are the lateral sewer pipes from the local sewer in roadway to approximately 1 to 2 m inside the property line of a parcel of land. The



service connection includes a junction box at the property line. Forcemains are sewers operating under pressure, which carry flow from a lift station to a gravity sewer discharge point or in some cases another forcemain.

All wastewater from the project area is to be collected and conveyed to one new treatment plant located on the site of the current San Fernando WWTP. Trunk main sewers will collect wastewater from all catchments. The size of the trunk sewers are chosen to match the design flows as closely as possible.

With the overall goal to sewer all properties in the project area, the proposed San Fernando collection system is shown in Figure 3-23. Pipe sizes range from 200mm to 1500 mm diameter.

The collection system is divided into subcatchments as seen on Figure 3-24. Subcatchment boundaries are based on topography and serve two purposes. First, the smaller subcatchments make it easier for operations and maintenance personnel to understand how the system works. Second, the division into subcatchments makes it possible to package and sequence construction contracts to control expenditures over time (cash flow). Details on sewer layouts in each subcatchment are shown on Figure 3-25 through Figure 3-41.

A summary of the proposed sewer pipe lengths per subcatchment is shown in Table 3-12.

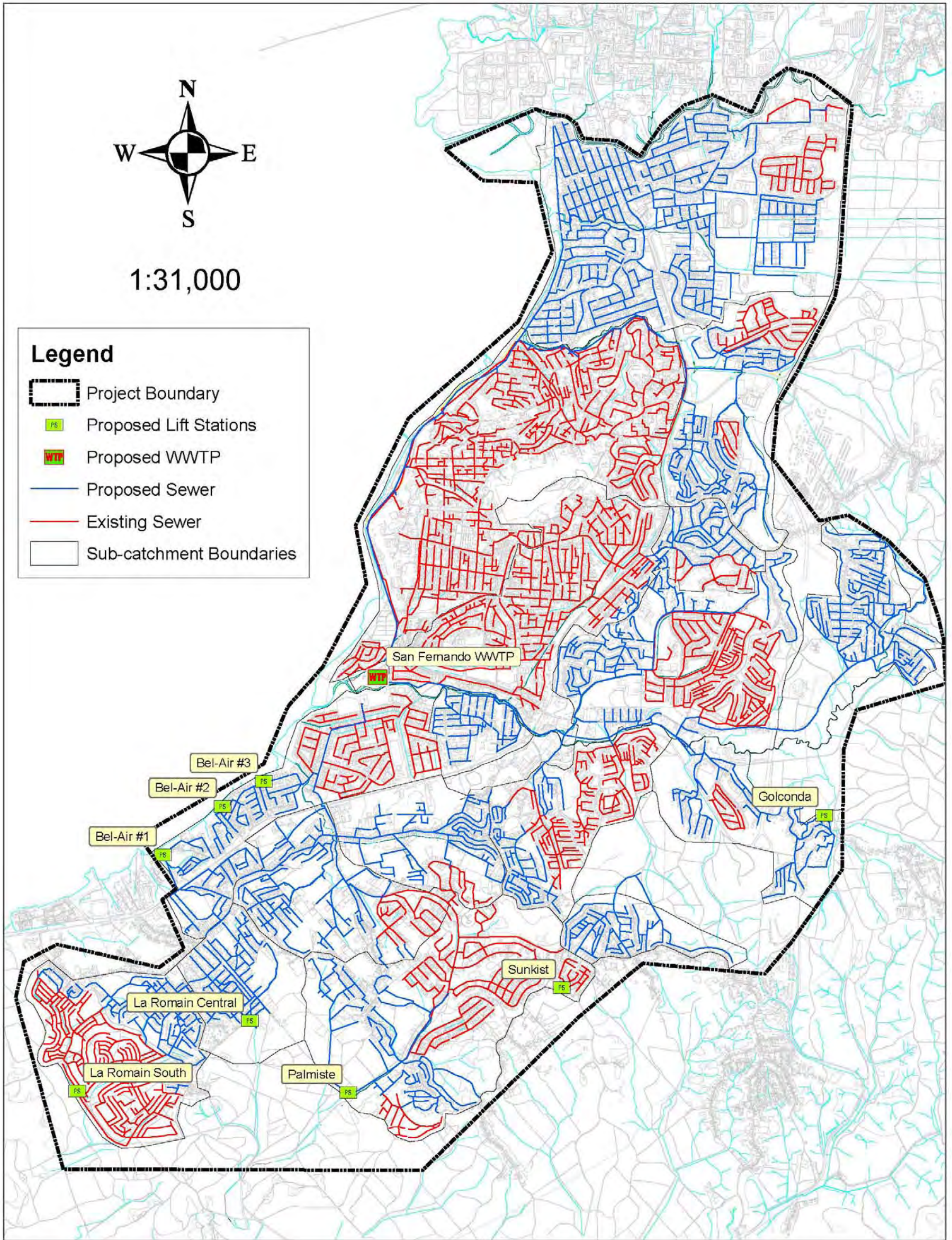


Figure 3-23 San Fernando Proposed New Collection System



Figure 3-24 San Fernando Collection System Subcatchments

**Table 3-12 New Collection System Pipe Length by Subcatchment**

Subcatchment	Pipe Length (km)
Marabella	48
Tarouba-Cocoyea	16
Cocoyea South	7
Pleasantville-Corinth	16
Vistabella-Gulf	6
San Fernando South	4
Ste. Madeleine	18
Bel Air - Gulf View	13
Green Acres	6
Duncan Village	11
Union Hall	8
Retrench-Golconda	11
La Romain North	15
La Romain Central	11
La Romain South	11
Palmiste South	13
Picton	9
<b>Total New Sewer</b>	<b>224</b>

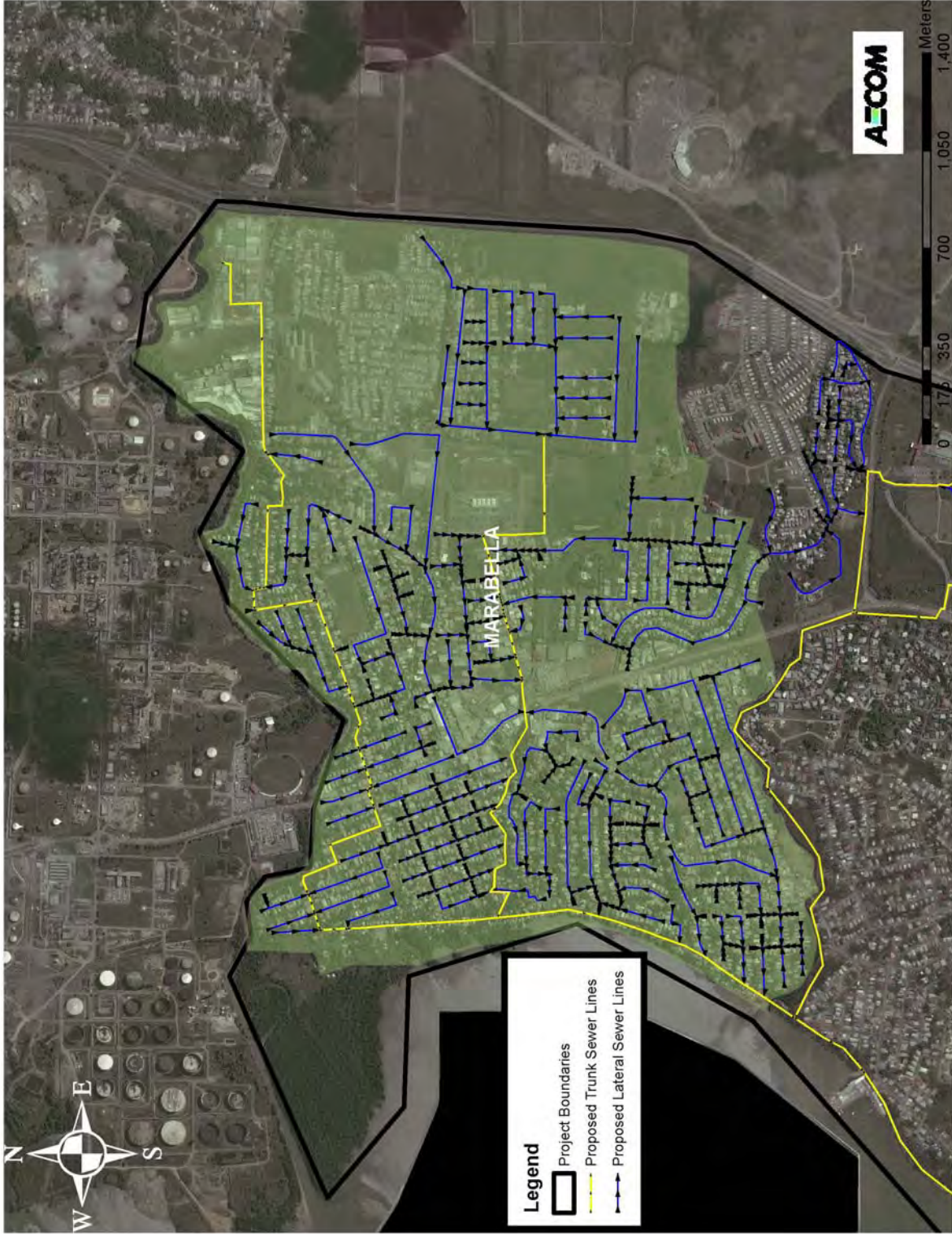


Figure 3-25 Marabella Subcatchment New Sewer Layout

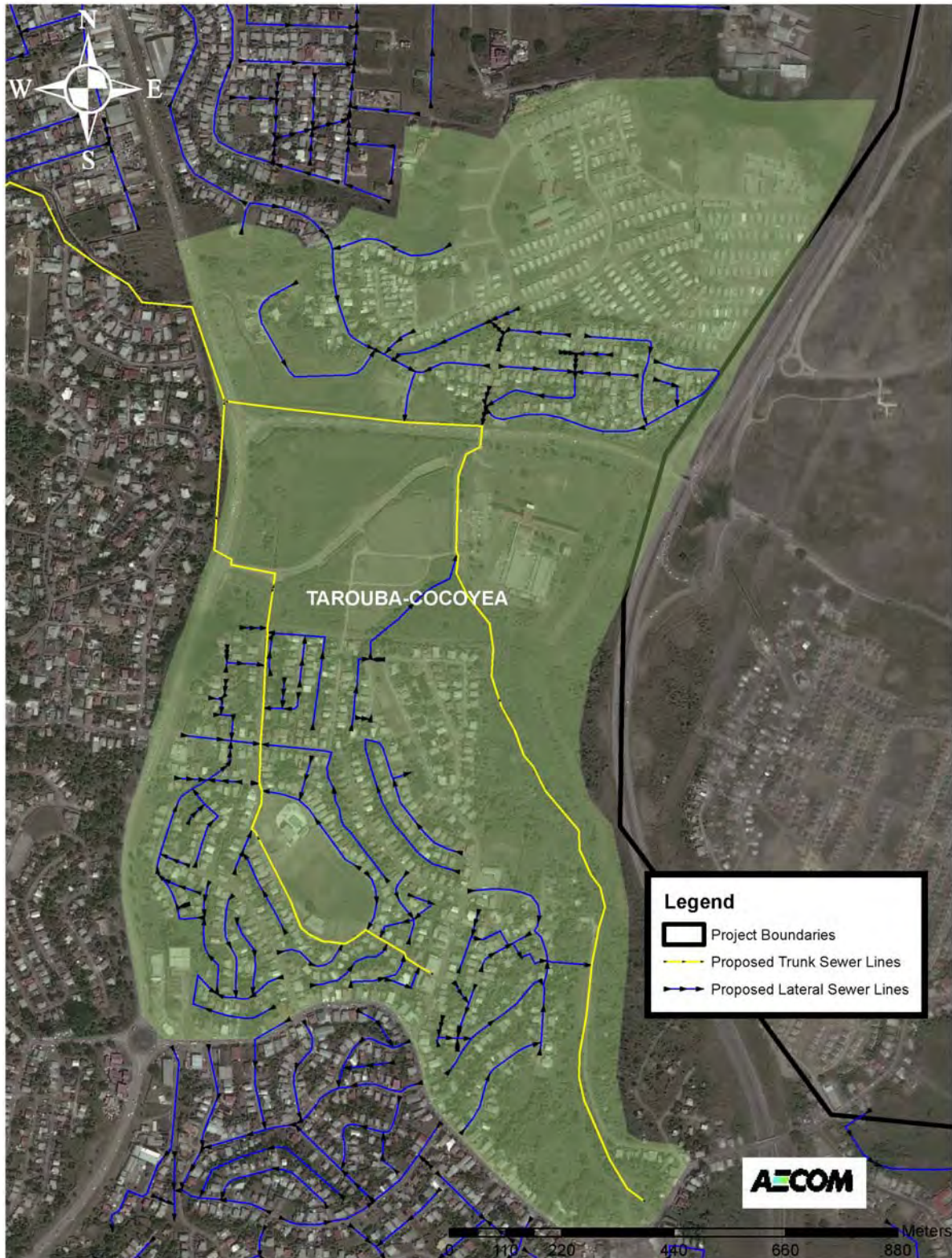


Figure 3-26 Tarouba-Cocoyea Subcatchment New Sewer Layout



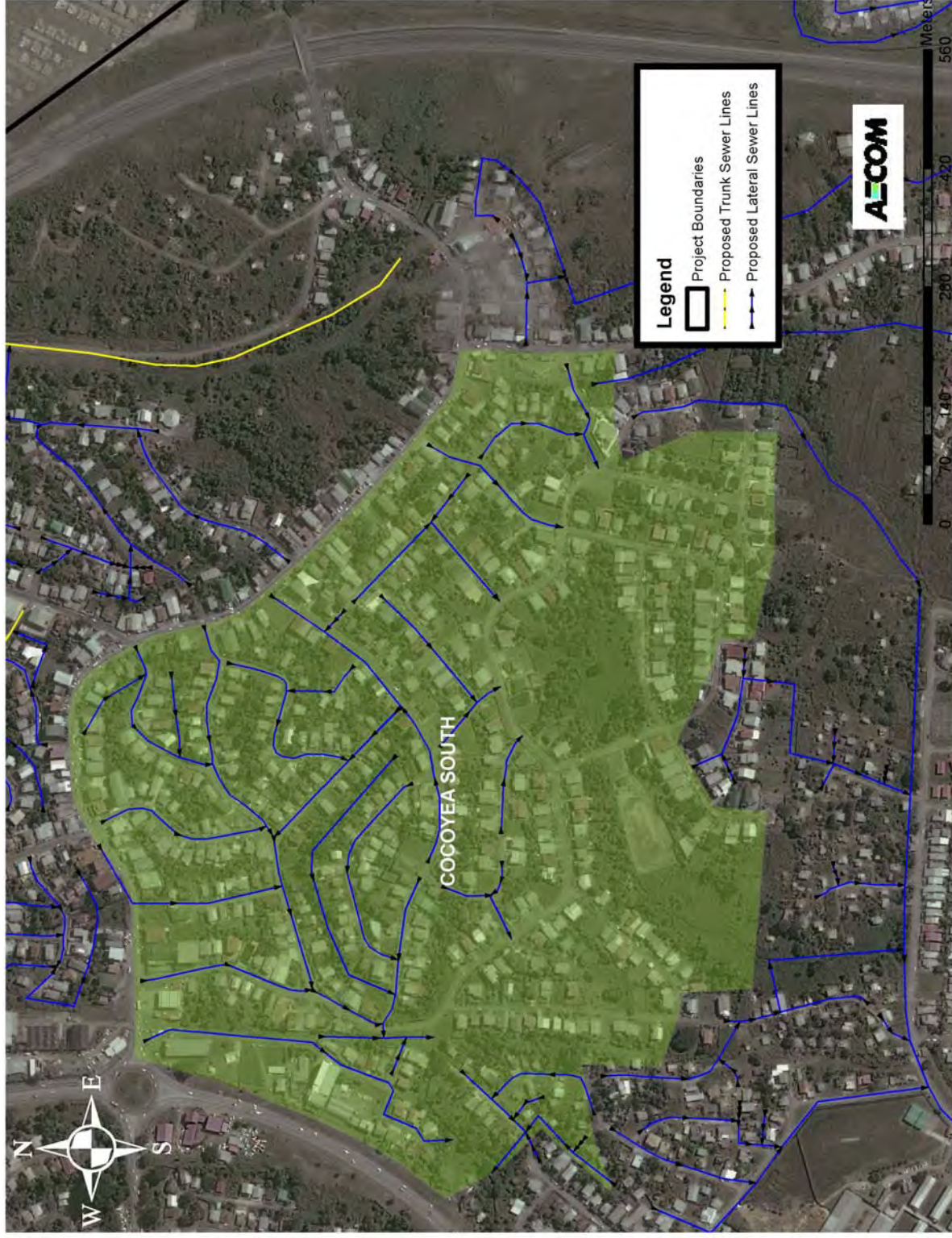


Figure 3-27 Cocoyea South Subcatchment New Sewer Layout

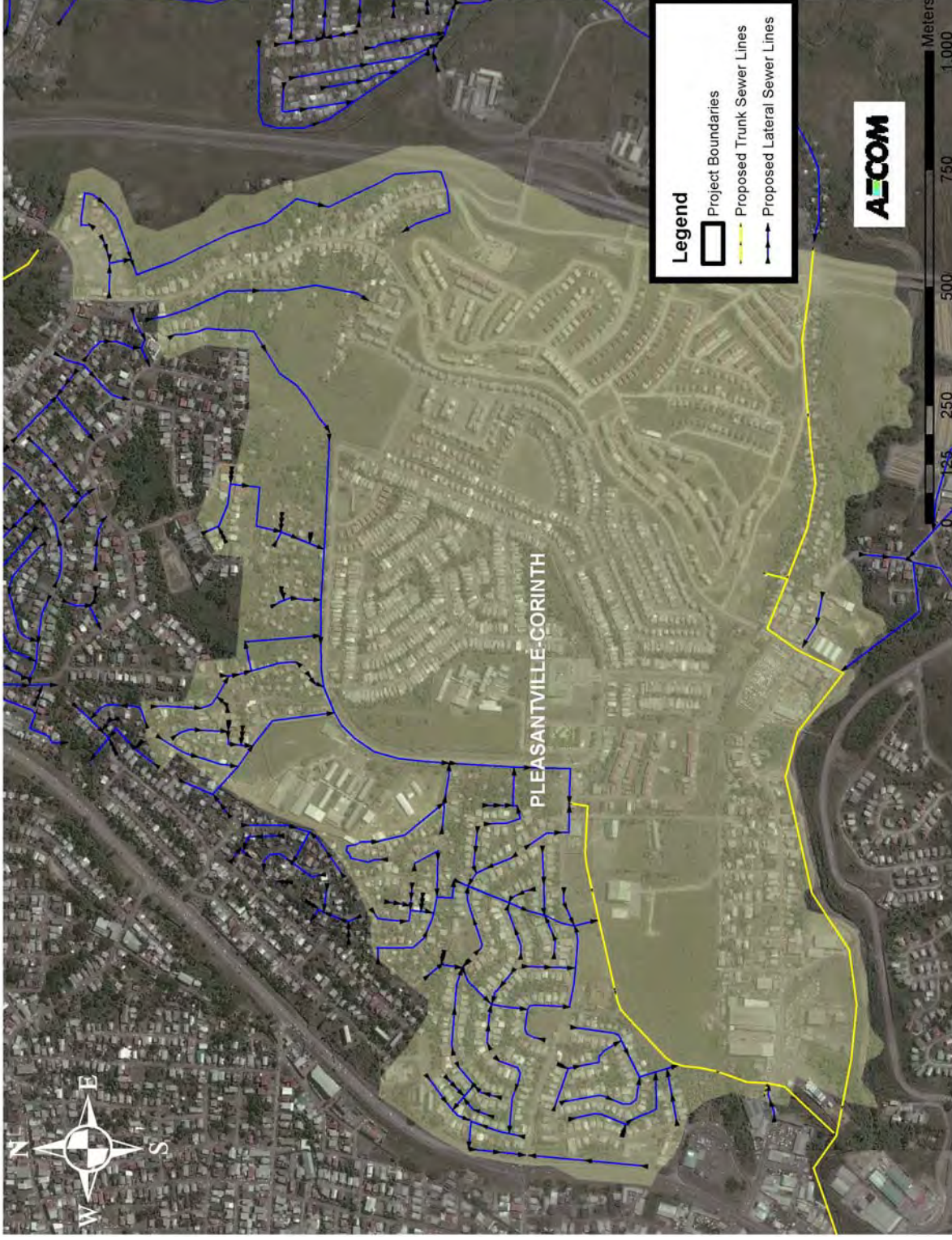


Figure 3-28 Pleasantville-Corinth Subcatchment New Sewer Layout



Figure 3-29 Vistabella-Gulf Subcatchment New Sewer Layout

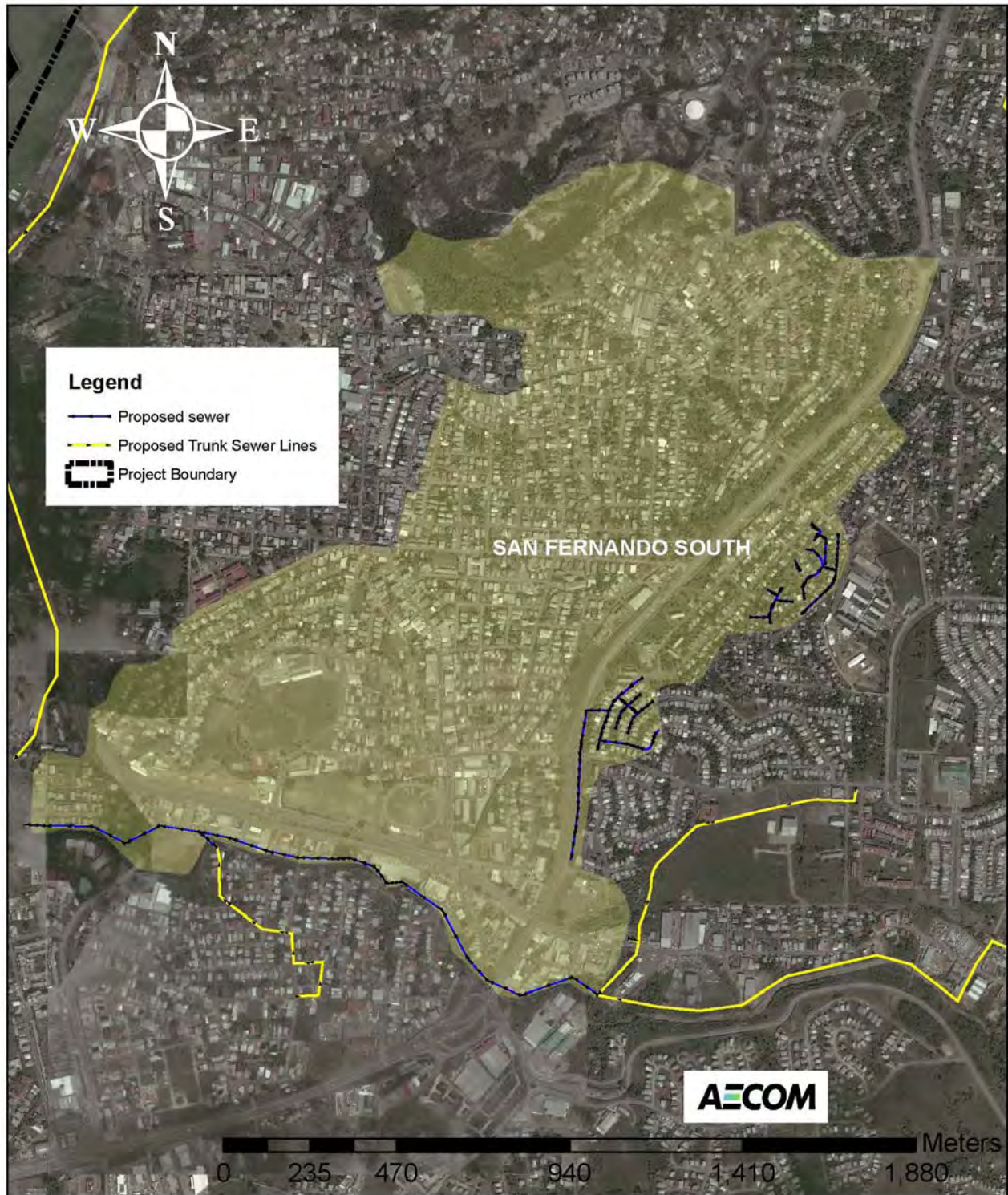


Figure 3-30 San Fernando South Subcatchment New Sewer Layout

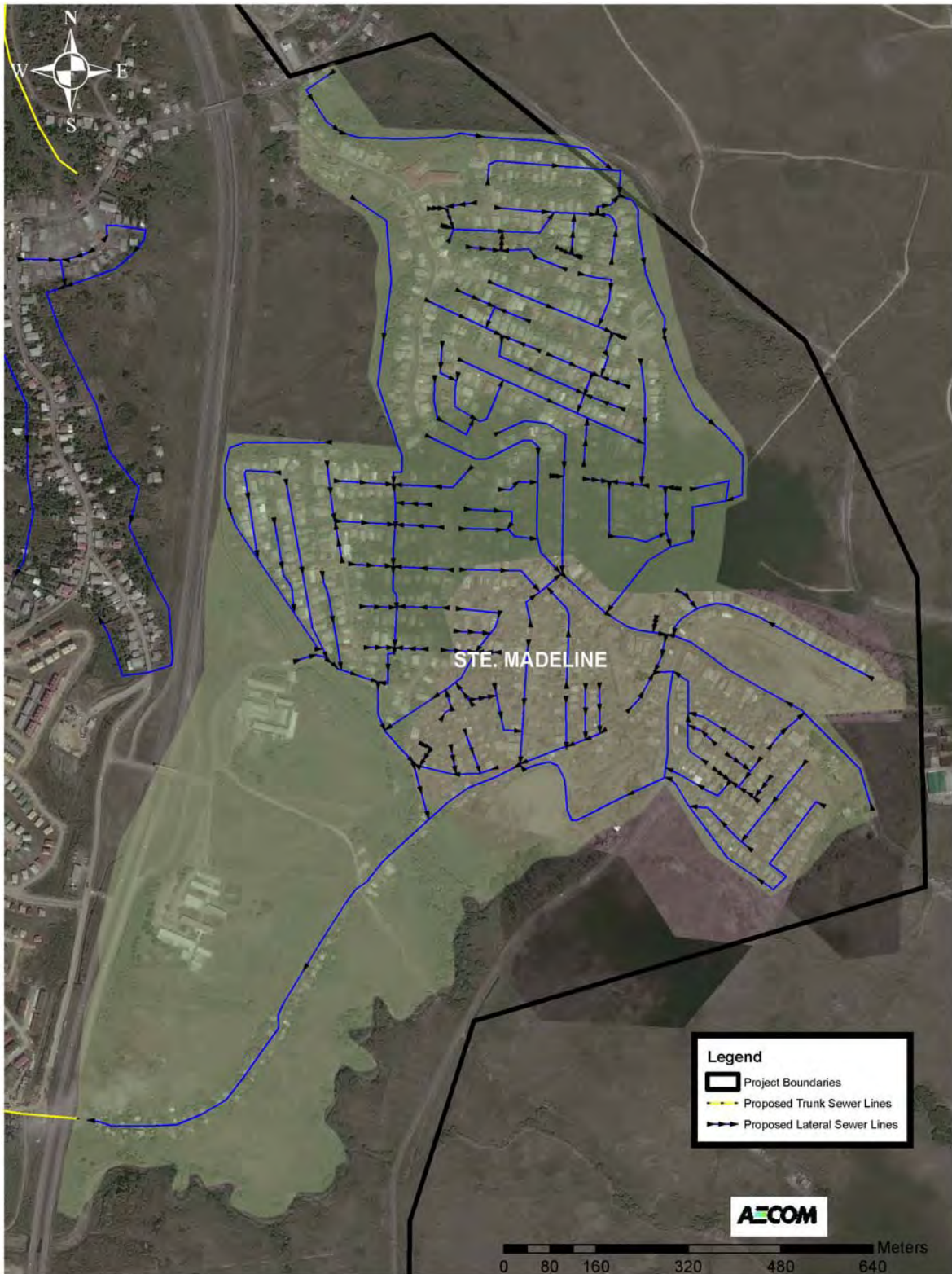


Figure 3-31 Ste. Madeline Subcatchment New Sewer Layout



Figure 3-32 Bel Air-Gulf View Subcatchment New Sewer Layout



Figure 3-33 Green Acres Subcatchment New Sewer Layout



Figure 3-34 Duncan Village Subcatchment New Sewer Layout





Figure 3-35 Union Hall Subcatchment New Sewer Layout

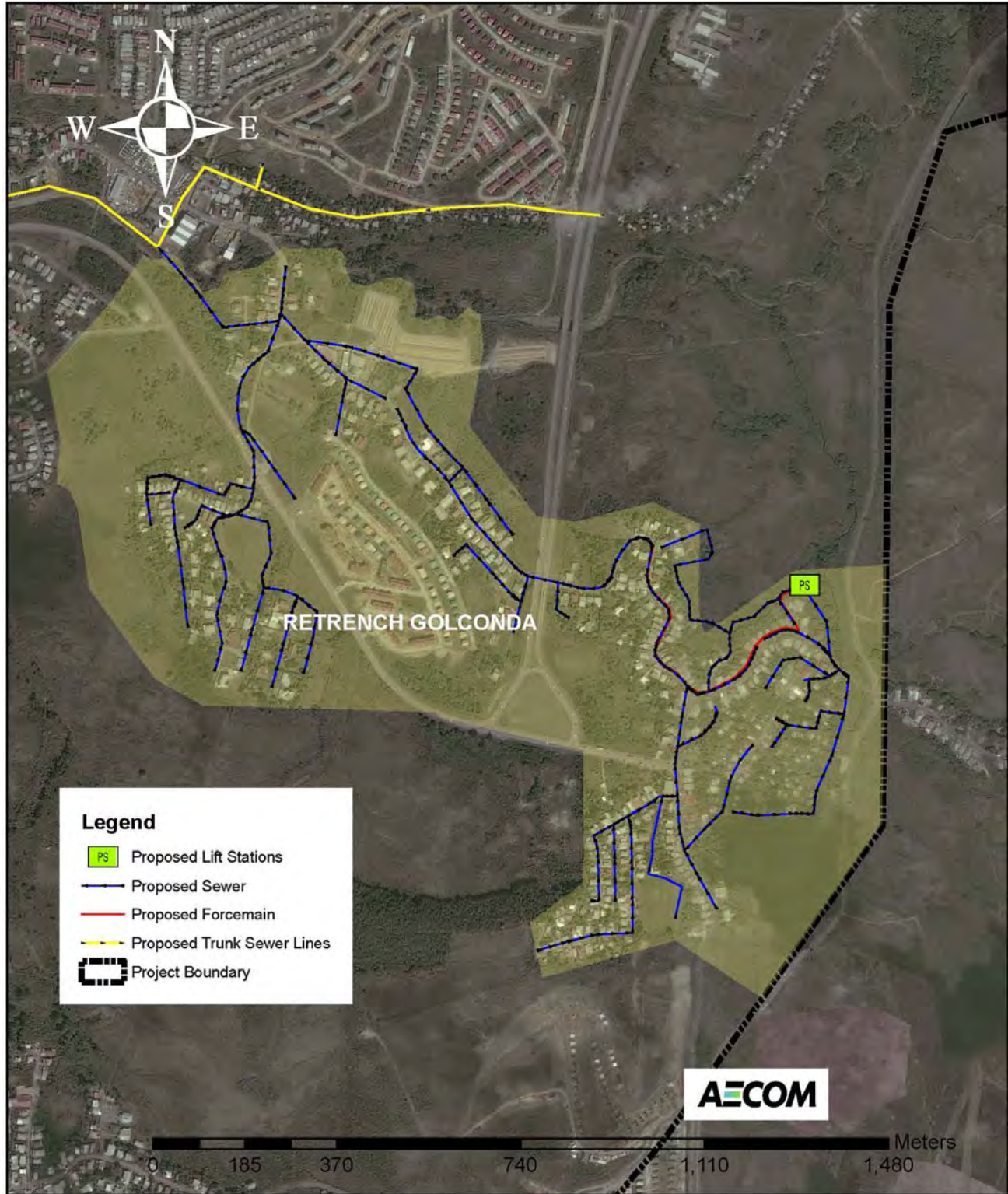


Figure 3-36 Retrench Golconda Subcatchment New Sewer Layout



Figure 3-37 La Romain North Subcatchment New Sewer Layout



Figure 3-38 La Romain Central Subcatchment New Sewer Layout

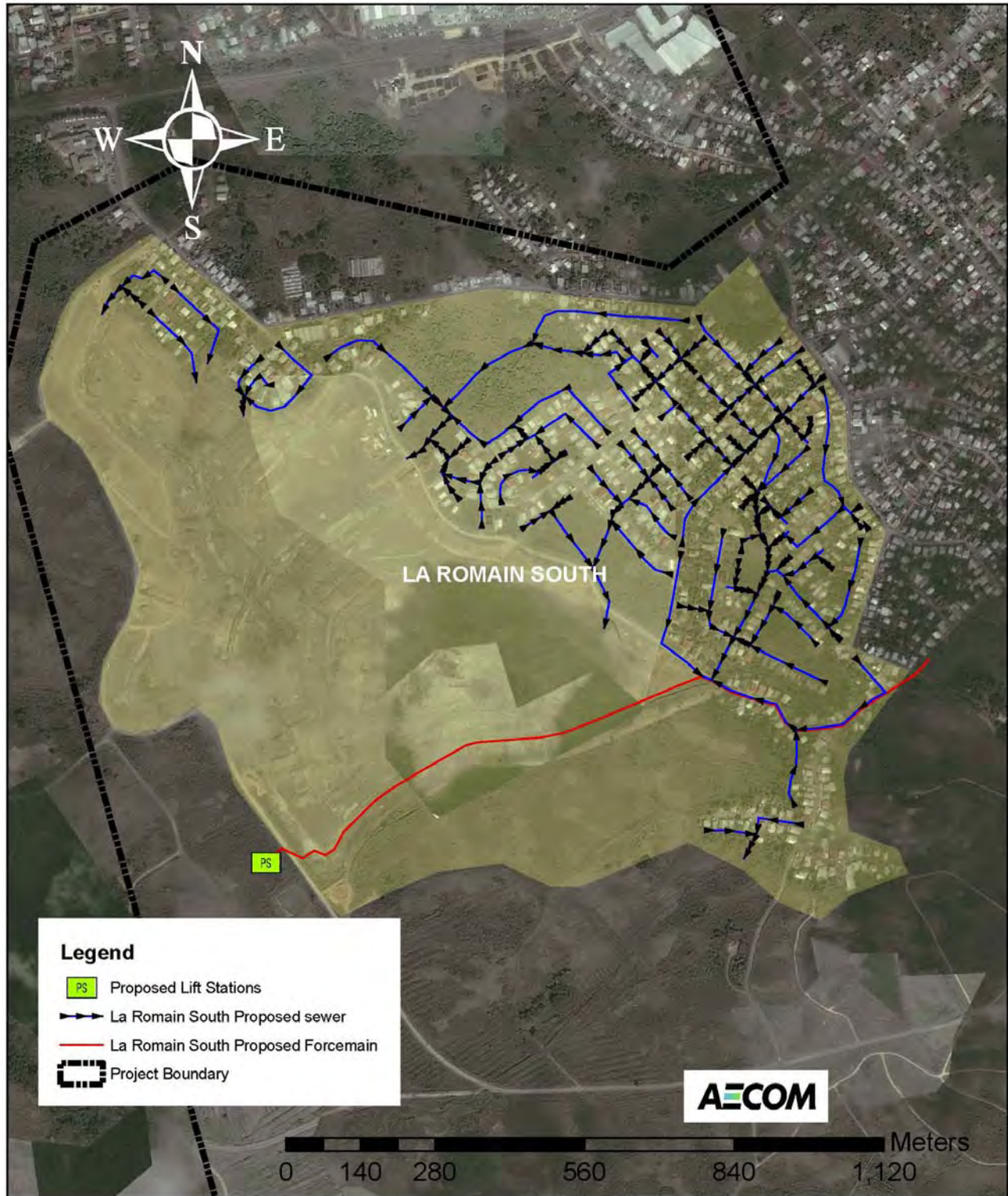


Figure 3-39 La Romain South Subcatchment New Sewer Layout

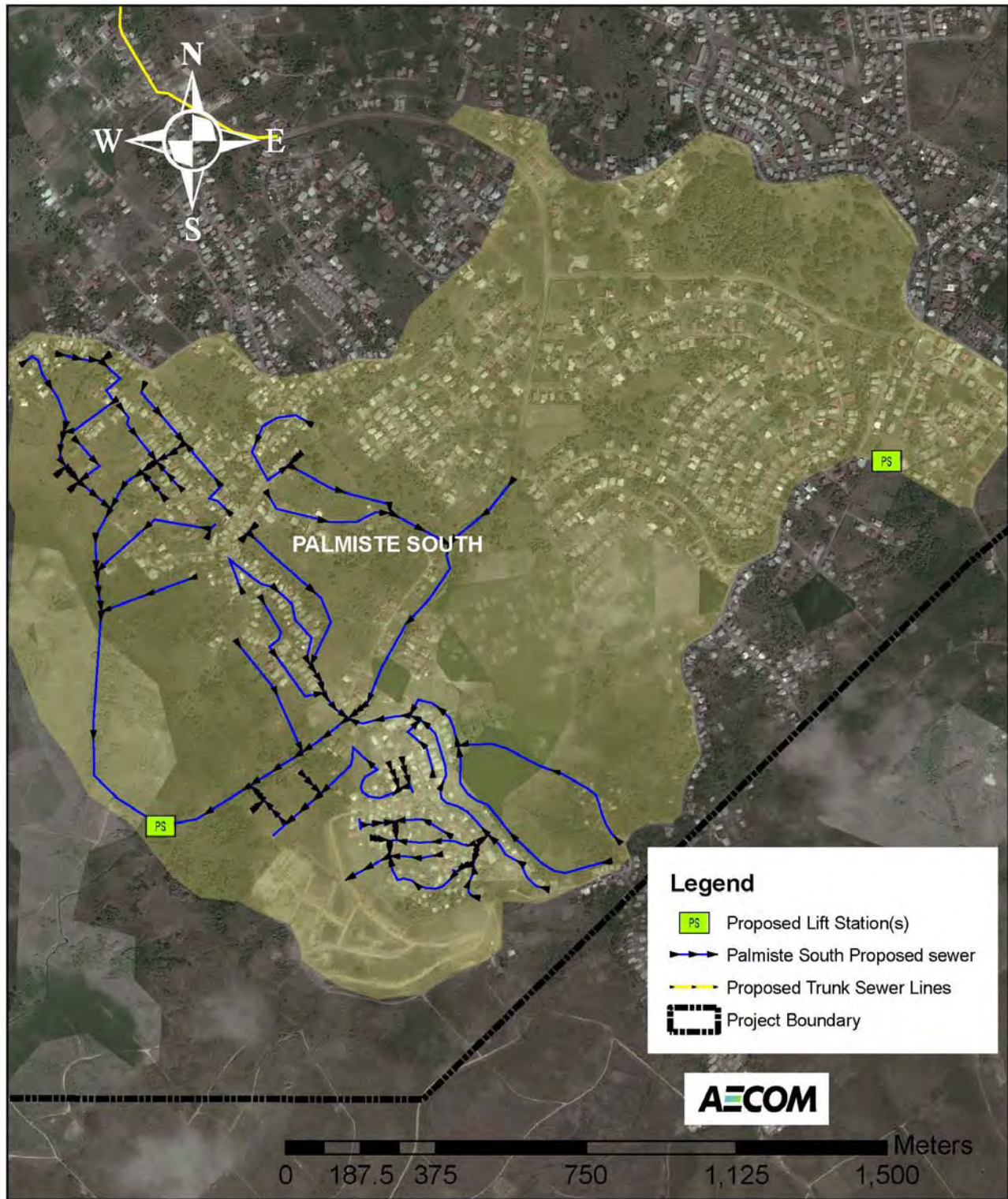


Figure 3-40 Palmiste South Subcatchment New Sewer Layout

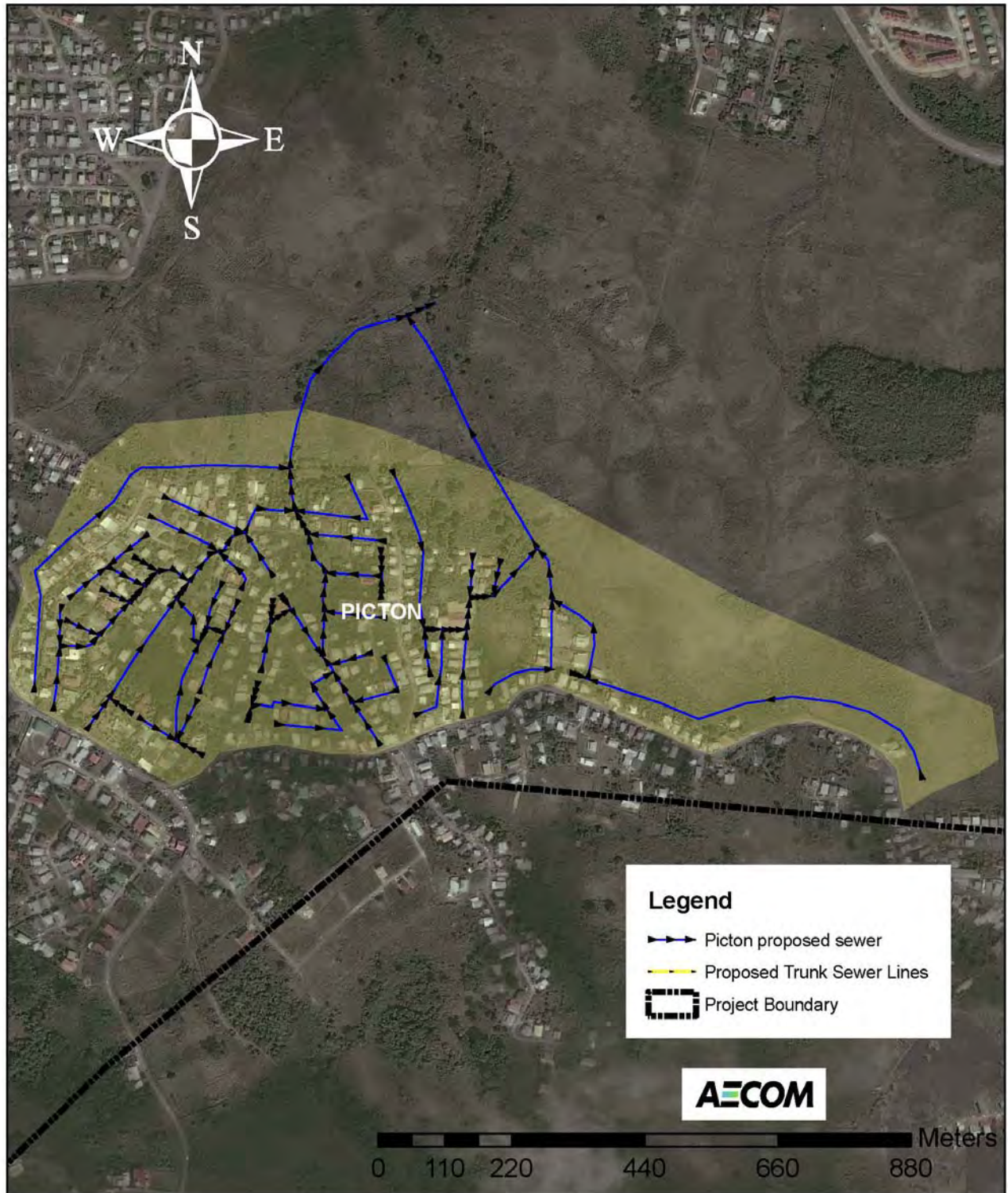


Figure 3-41 Picton Subcatchment New Sewer Layout



### 3.11 Wastewater Lift Stations

Wastewater lift stations are typically required when the depths of the sewers become so deep that construction costs become excessive and the resulting sewers are difficult to maintain. Lift stations are also relatively high capital cost installations, and they impose an annual operating and maintenance cost for pumping and upkeep. Since mechanical and electrical components can fail, lift stations reduce the reliability of the wastewater collection system. One of the key design objectives was to minimize the number of lift stations within the project area.

All existing lift stations in the project area will be eliminated, and replaced with gravity sewer. All abandoned lift stations will be demolished once construction of the new collection system is in operation and the stations are no longer needed.

Eight new lift stations are needed to pump wastewater collected in the southern subcatchments, which are situated south of a ridge line running east-west between San Fernando and Palmiste (Figure 3-23). These lift stations have been categorized by flow into three types. Type 1 stations handle flows less than 20 L/s, Type 2 stations handle flow greater than 20 L/s up to 150 L/s, and Type 3 stations handle flows greater than 150 L/s. Table 3-13 lists the eight lift stations along with the design PWWF capacity and the designated type. **Appendix C.3** has examples of drawings for all three lift station types.

**Table 3-13 Lift Station Information**

Lift Station	Design Flow (PWWF)		Type
	m <sup>3</sup> /day	L/s	
La Romain South	12,325	143	2
La Romain Central	17,542	203	3
Bel Air #1	1,507	17	1
Bel Air #2	1,871	22	2
Bel Air #3	2,482	29	2
Palmiste #1	605	7	1
Palmiste #2	7,842	91	2
Retrench-Golconda	1,505	17	1

### 3.12 Pre-Construction Activities

#### 3.12.1 Land Acquisition

The land used for the San Fernando WWTP is currently owned by WASA. WASA also owns a relatively large parcel of land south of the existing WWTP site and the Ciperio River. The southern parcel will be used for the new access road into the WWTP and for construction lay down and staging.

Locations of the new lift stations have been selected to avoid disruption to existing land use by placing the facilities on the site of an existing lift station or WWTP, or on a parcel that is currently





undeveloped (Table 3-14). Transfer or purchase of these lands for the purpose of constructing new lift stations is being pursued by WASA.

**Table 3-14 Lift Station Location Descriptions**

Lift Station	Location
La Romain South	Site of proposed WWTP for the new La Romain housing development
La Romain Central	Empty lot
Bel Air #1	Empty lot
Bel Air #2	Empty lot
Bel-Air #3	Small area on edge of park
Palmiste #1	Site of existing (non-functional) Palmiste WWTP
Palmiste #2	Site of existing (non-functional) Sunkist WWTP
Retrench-Golconda	Empty lot

While the majority of the new sewers will be constructed in public roadways, several sewer alignments will be located off-road. For these alignments it will be necessary for the construction contractor to obtain construction easements, and for WASA to obtain permanent easements for maintenance purposes. WASA is pursuing the necessary permanent easements for maintenance purposes.

### 3.13 Construction Phase

#### 3.13.1 Project Phasing

The San Fernando project will most likely be constructed in phases to accommodate operation of existing facilities, and minimize disruption in the community, while achieving a cash flow that will be affordable. The primary objective is to achieve maximum benefit during the first phase of construction by building the new WWTP and connecting areas with existing sewers to the new plant.

The proposed Phase I would consist of two construction contracts as follows:

- Contract No. 1 – New San Fernando WWTP.
- Contract No. 2 – Trunk sewers constructed using trenchless techniques plus connecting sewers between existing sewer areas and the new trunk lines. Elements of this contract would include:
  - Gulf trunk sewer from Marabella to the WWTP.
  - Ciper trunk sewer from Solomon Hochoy Highway to the WWTP.
  - Vistabella trunk from San Fernando Bypass Road to Gulf trunk sewer.
  - Connecting sewers to tie in the following sewer areas:
    - San Fernando
    - Pleasantville
    - Corinth HDC development



- Union Hall
- Parts of Tarouba and Cocoyea

**Table 3-15 Phase I of Subcatchment Construction Information**

Subcatchment	2035 PE	New Sewer Length, km	Comments
Marabella	0	2.9	Trunk line to be constructed under Trenchless Contract
Vistabella-Gulf	15,190	5.1	Trunk line to be constructed under Trenchless Contract
Tarouba-Cocoyea	2,120	2.2	Tie into Tarouba North and Tarouba Hts. lift stations and Westpark WWTP
San Fernando South	8,275	1.8	Trunk line to be constructed under Trenchless Contract
Pleasantville Corinth	6,040	3.1	Connection to existing Pleasantville lift station
Bel-Air Gulf View	4,230	0.2	Tie into existing Gulf View WWTP
Green Acres	0	0.1	Trunk line to be constructed under Trenchless Contract
Union Hall	4,180	0.7	Connection to existing Union 1 & 2 lift stations

Graphically, Phase I is seen in Figure 3-42.



Figure 3-42 Construction Phasing, Phase I



At completion of Phase I, wastewater entering the existing San Fernando sewer system and most of the sewer areas that naturally drain to the Ciperó River would be treated in the new WWTP. The initial ADWF to the plant would be approximately 16 ML/d, which is 36 percent of the ultimate design ADWF of 45 ML/d. This equates to a service population of 40,035 pe out of 111,600 pe (2035 design year).

Additional phases would consist of one or more sewer construction contracts depending on the available funding. The number one priority would be to construct the trunk sewer from the WWTP, through the Gulf View residential area to Dumfries Road, and south along Dumfries Road to Palmiste Avenue. Completion of this trunk sewer would provide conveyance capacity to connect all the subcatchments located in the southern most portion of the project. Table 3-16 below lists the subcatchments that would be included in later construction phases. Priorities would be assigned based on several factors including connection of existing sewer areas, e.g., Palmiste South; environmental issues such as anticipated water quality improvement; and construction costs.

**Table 3-16 Additional Phases of Subcatchment Construction Information**

Subcatchment	2035 PE	New Sewer Length, km	Comments
Marabella	16,450	45.1	Small area sewerred; decommission Harmony Hall WWTP
Tarouba-Cocoyea	3,910	13.8	Mixture of sewerred and unsewerred areas
Cocoyea South	3,250	7.0	Includes remediation of Scotland Drive sewers
San Fernando South	435	2.2	Sewers from Scotland Drive, Blitz Village and Chaconia North connected to existing San Fernando sewer network
Pleasantville Corinth	5,130	12.9	Mixture of sewerred and unsewerred areas
Ste Madeline	4,000	18	Densely populated unsewerred area drains into Ciperó River
Bel-Air Gulf View	2,090	12.8	Densely populated area adjacent to Gulf
Duncan Village	3,660	11	Mixture of sewerred and unsewerred areas; enable elimination of 2 lift stations in Palmiste (Pollonais 1&2)
Green Acres	1,320	5.9	Densely populated unsewerred area
Union Hall	3,390	7.3	Existing sewers connected as part of Phase I
Retrench Golconda	3,360	11	North section drains to Ciperó River; south section drains south
Palmiste South	6,140	13	Mixture of sewerred and unsewerred areas; enable elimination of Palmiste WWTP and Kelvin Rd. lift station
La Romain North	3,520	15	Enables elimination of Palmiste Blvd. lift station
La Romain Central	3,730	11	
La Romain South	9,570	11	Enables elimination of proposed La Romain EMBD WWTP
Picton	1,610	9	Cost per sewerred property high due to remoteness from trunk sewer



### 3.13.2 Sewer Location and Alignment

Generally sanitary sewers are in locations accessible to each property facing a roadway. Sanitary sewers will be installed along roadways where possible, and generally be located at an offset of 1.5 m from centerline of the roadway. While it is common practice to locate sewers and other utilities offset from the centerline of the roadway so that when maintenance such as sewer cleaning is conducted, one lane of traffic can be maintained, the final location is dictated by other factors such as location of existing utilities, road width, and elevation of buildings relative to road elevation. In cases where sanitary sewers cannot be located along roadways, a sewer easement will be required. The requirement for easements will be minimized to the degree possible by keeping sewers within the road right of way as much as possible; however, for properties in low lying areas and not located near roadways, an easement is unavoidable. Manholes must be located in accessible areas of the roadway or easement for maintenance purposes.

### 3.13.3 Crossing Clearance to Sewers

It is essential that all pipeline crossings be inventoried as they affect both the alignment and profile of the sewer network. The plan-profile drawings will show the existing utilities and new sewers that cross will be located at the required separations to meet utility requirements. The National Gas Company (NGC) natural gas pipelines are of particular importance and require a minimum separation of 0.9 m where crossings have been identified. When crossing over or under watermains of 450 mm in diameter or less, a minimum clearance of 0.15 m is required. This is the minimum to be used only when spatial constraints exist. In normal situations, a minimum of 0.3 m clearance will be provided. Watermains larger than 450 mm diameter require a minimum clearance of 0.6 m. A minimum clearance of 0.23 m is required for storm sewers/ drains. Also, the minimum horizontal separation recommended between watermains and sewers is 2.5 m. For buried power lines (T&TEC), a minimum spacing of 0.5 m will be maintained. For telecommunication lines (TSTT), a minimum spacing of 0.3 m will be maintained.

### 3.13.4 Pipe Bedding, Backfill and Reinstatement

Locally sourced granular bedding material is recommended for sewer pipe and manhole installation as it will be readily available and at a reasonable cost. Sewer pipe should be placed on a minimum of 150 mm of bedding sand and 300 mm of cover above the pipe crown.

Sand bedding will be used for sewers installed above the water table. For sewers below the water table, a free draining granular bedding material will be used. A variety of backfill materials will be specified depending class of roadway, location of water table, and type of pipe material. It is anticipated that excavated material can be used as common backfill for sewers off roadways and as select backfill under roadways if it meets the specification requirements for material composition, strength, compaction and gradation. This will be determined through testing by the contractor. The backfill material must be compacted in 300 mm layers using mechanical compaction equipment to meet compaction specifications stipulated in the contract documents. For all roadways compaction is to be 95% of modified proctor in accordance with ASTM D698. Key standard details for trench backfill in wet and dry conditions are included in **Appendix C.4**.

Roadways will be reinstated after trenches have been backfilled. Most roadways in the project area are asphalt surface. The thickness of asphalt, base course and sub-base materials will depend on the classification of roadways, which is based on vehicular traffic. Class 1 roadways are main roads, Class



2 roadways are secondary paved roads, and Class 3 roadways are gravel roads. Key standard details for road reinstatement are included in **Appendix C.4**.

### 3.13.5 Sewer Installation Techniques

Various techniques were evaluated for installation of the sewer lines within the project area. Factors affecting the installation include:

- Traffic disruption and disruption to the general public and adjacent property owners
- Interference with existing utilities
- Soil conditions
- Cost

Soil conditions that affect sewer construction methods and cost the most include existence of rock, groundwater levels, and variability in soil conditions. The existing buried infrastructure also has a major impact on both the selection of construction technique and the risks associated with its use.

The most common installation method for sanitary sewer piping is conventional open cut trenching. It is usually the most economical alternative when installing pipe at relatively shallow depths, especially in suburban or rural areas. In developed urban areas the extent of disruption and impact to the area from construction activities is more significant with open cut trenching. Where sewers are deeper, stability of side slopes can pose a problem depending on soil conditions. Trench cages and shoring must be used to protect workers and reduce slope destabilization. Where installation is below the water table, trench dewatering is required which can add significantly to the cost. Existing utility crossings need to be accommodated and repaired if damaged. The selection of the alignment is extremely important to minimize conflicts with existing utilities, minimize disruption and reduce restoration costs.

In highly developed areas with existing underground infrastructure present, trenchless installation techniques are often justified. The capital cost of trenchless techniques including pipe jacking, microtunnelling, and horizontal directional drilling (HDD) are higher than conventional open cut trenching but may be justified when the direct and indirect social costs of disruption to the public are considered. For microtunnelling and pipejacking, shafts ranging in size from 3-6 m diameter are dug and spaced along the route. These shafts affect a smaller portion of land when compared to the open cut construction methods.

For San Fernando, trenchless techniques (microtunnelling/ pipejacking) have been included in the design for the trunk sewers along the Gulf Coast, Marabella River, Vistabella River, and Ciperio River. These Trunk sewers are deep, below the water table, in congested areas, and range in diameter from 750 mm to 1500 mm. The shaft locations along the trunk lines where the trenchless technology will be used in the design are seen in Figure 3-43.

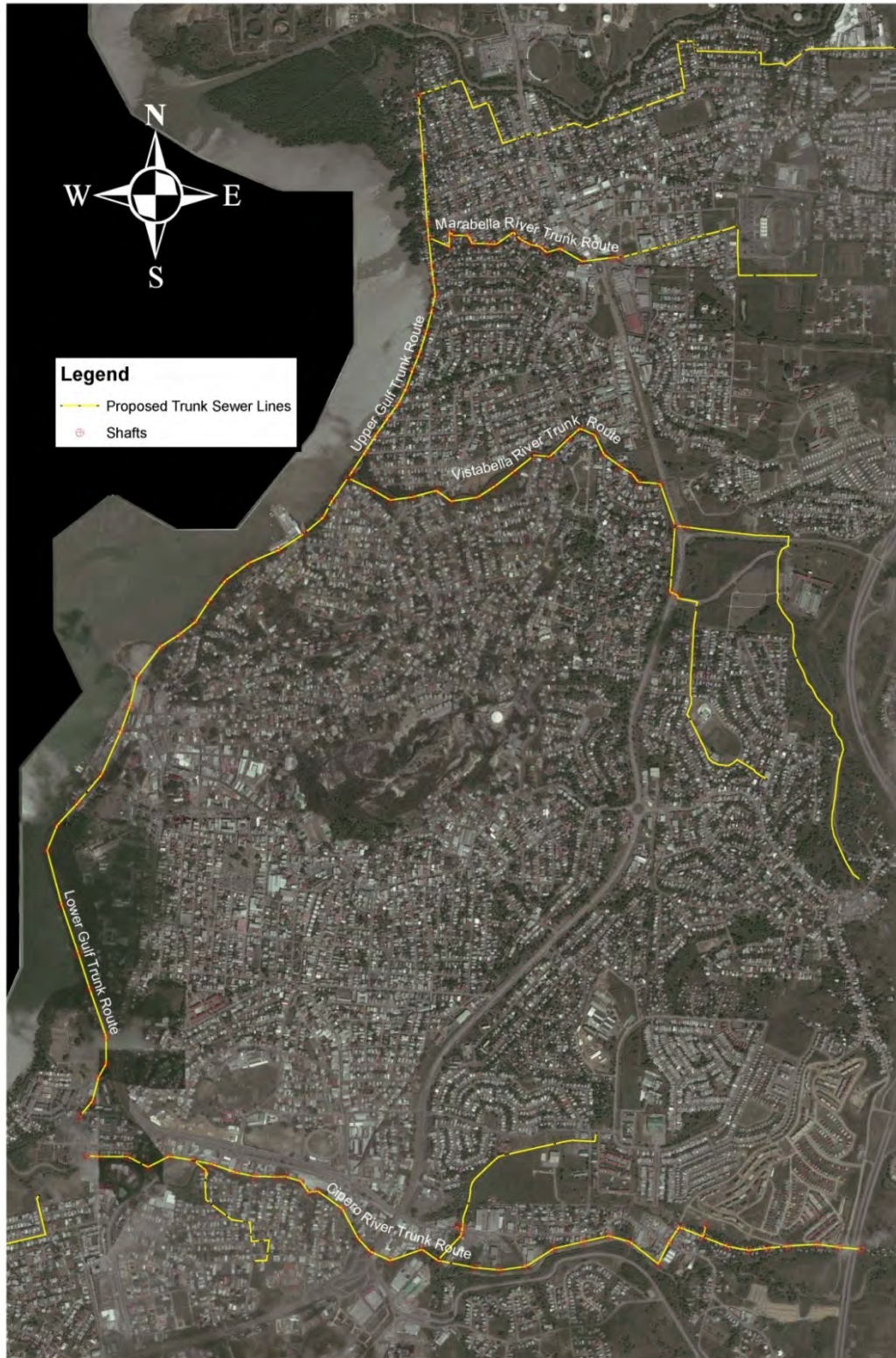


Figure 3-43 Trunk Sewer and Shaft Locations



### 3.13.6 Site Grading and Drainage

In all instances, surface runoff will be directed away from buildings to the site perimeter where it will be collected in a series of box drains and ditches that connect to the drainage channels in the area. Internal drainage swales/ditches will be designed as required to carry runoff to the appropriate drainage channel. All roadways will be crowned and elevated as required above existing ground to provide positive drainage to adjacent ditches to ensure the pavement structure remains in an unsaturated condition. Roadway profiles will be coordinated with building elevations at delivery points to maintain the appropriate elevation of vehicles in relation to the facility they are accessing. Roadway profiles will also be coordinated with piping layouts to ensure adequate clearance between pavement structures, ditch inverts and pipes.

### 3.13.7 Erosion Control

Erosion control measures will be considered along sections of sewer adjacent to river and stream beds and where the sewer crosses a river, stream and major drain. Erosion control blankets, rip rap, and concrete encasement will be utilized to ensure that erosion of pipe support materials does not occur during the rainy season. Erosion control during construction and other environmental protection requirements are covered in the project technical specifications, specifically Environmental and Aesthetic Protection, and Erosion Protection, which are included in **Appendix C.5**.

### 3.13.8 Traffic to Site

Traffic to the San Fernando WWTP Site will vary throughout the 24 month construction period. Estimations of traffic based on vehicle types are below:

- Worker Vehicles - Daily car/ light truck traffic will occur from 7am-5pm daily and range from:
  - 15 vehicles in months 1 to 5.
  - 40 vehicles in months 7 to 24.
- Lowboy Semi Trailers – Divided into construction equipment and structural piles:
  - Cranes, excavators, backhoes and other equipment will be brought to the site during months 1-16.
  - Piles - Within the first 12 months of construction, 2 vehicles per day for up to 4 months.
- Dump Trucks – Within the first 12 months of construction, 20 trips per day for up to 3 months.
- Concrete Trucks – In months 7-16 of construction, an estimated 1600 trips will be made to the WWTP site, usually in groups of 16 trips per pour of concrete.
- Flat bed semi-trailers – In months 14-24 equipment will be brought to the WWTP site, by up to 60 trips.

As the majority of the collection system will be constructed in road right-of-ways, construction will impact traffic throughout the project area. The impact on traffic and the mitigating measures are discussed in further sections of this report.





### 3.14 Operation of San Fernando Wastewater System

#### 3.14.1 Labour Requirements

The anticipated on-site staff needed to operate and maintain the new WWTP is as follows:

Managerial	3
Administrative support	2
Operations	6
Laboratory	2
Maintenance	5
<hr/>	
Total	18

The WWTP administration building will house the offices for the managerial and administrative staff. In addition, an office will be provided for the laboratory supervisor and two offices for chief operator and visitors. A locker and change room intended for the managerial and administrative staff will include lockers, showers, and washrooms. In addition, two separate washrooms will be provided for staff and visitors' use. A lunchroom with a refrigerator, microwave oven and a sink will be provided.

The WWTP utility building will have an office area for maintenance staff, lockers, showers, and change-room for the operations and maintenance staff as well as a lunchroom, washrooms and a laundry for the cleaning of clothing.

Additional staff will be required for maintenance of the collection system and lift stations. The anticipated field staff will include two crews each comprising a crew chief and two labourers. Their office base will be near the WWTP, possibly in a future facility located on the WASA land south of the Ciperio River.

#### 3.14.2 Treatment Plant Process Control

The WWTP will be using the activated sludge process to convert colloidal and soluble contaminants into settleable solids that can be removed in gravity settling basins. The conversion is achieved by bacteria that use carbonaceous compounds for food and produce more biomass. This process is controlled by making sure the bacteria have the right environment (balance of food, oxygen and other nutrients) to perform effectively. Secondary effluent from the settling basins will be filtered and disinfected to achieve reclaimed water quality. The activated sludge process produces excess biomass that must be removed from the process and stabilized.

Operators will monitor the treatment processes using permanently installed field instruments and portable measuring devices. Based on operating data, dissolved oxygen levels will be adjusted and the inventory of biomass in the reactors will be maintained at appropriate levels.

At the WWTP, waste activated sludge (WAS) removed from the activated process will be thickened, digested, and dewatered to cake form and hauled off site. Operators will need to make up batches of polymer used to condition the sludge ahead of the dewatering equipment and monitor the operation of the equipment while it is running.



Other treatment processes that require monitoring and some level of control to keep the overall treatment system operating optimally include:

- Fine screening.
- Grit removal.
- UV disinfection.
- Effluent filtration.

The treatment plant will be equipped with laboratory facilities fully equipped to conduct all necessary process control tests including chemical oxygen demand (COD), total suspended solids (TSS), and nitrogen compounds.

### 3.14.3 Instrumentation and Control

The WWTP will be staffed 24 hours per day, seven days per week (24/7) with at least one operating crew on duty at all times. This level of attendance is consistent with semi-automatic operation wherein provision for operator intervention will be provided. In a semi-automatic system, set point adjustment becomes the responsibility of the operators and some of the open-close and start-stop functions are manual. The duty crew will be trained and directed to make the necessary process modifications to optimize the treatment system on an ongoing basis.

Field instruments will be wired to a series of marshalling panels mounted in the electrical rooms. The main marshalling panel locations will be in the utility building control room and the sludge dewatering building electrical room. Adjacent control centres will receive the wiring from the marshalling panels into programmable logic controllers (PLCs). All control functions and monitoring of digital input and output will be through these PLC centres.

The control centres communicate through an Ethernet network connection, which further connects to a series of human-machine interface (HMI) devices and an archive computer. One HMI will be located at each control centre and in the control/ operations room in the Administration Building.

### 3.14.4 Waste Management

Measures that could be taken to minimize pollution caused by construction or its related activities are:

- Provide temporary sanitary facilities for workers.
- Provide regular servicing of temporary sanitary facility by septage truck, with disposal to a proper disposal facility.
- Install silt control fences along sewer trench construction, and around stockpiled materials.
- Require the contractor to provide a Construction Environmental Management Plan to address the collection and proper disposal of all unsuitable construction materials or refuse.
- Recycle all excavated materials where suitable.
- Provide a designated landfill site for disposal of surplus construction materials and/or contaminated soils, and monitor the usage of the site by the contractor.

Residual materials physically removed from the wastewater during treatment (screenings and grit) will be washed and dewatered before sending to landfill for disposal. The dried biomass, commonly known



as biosolids, is suitable for land application in accordance with the USEPA Class B Biosolids (with monitoring).

### 3.15 Demolition and Decommissioning of Existing Facilities

The establishment of a comprehensive wastewater collection system leading to a single WWTP involves the decommissioning and demolition of several wastewater treatment plants and lift stations in the project area. All operating facilities will remain in service until the new facilities are constructed and placed in service. The following activities are involved in the process and will be employed in the project area:

- Removal and salvage of electrical, instrumentation and associated devices, ventilation and air conditioning, plumbing and process and other mechanical equipment and piping as necessary.
- Rerouting and/or terminating utilities.
- Shutting off, capping and abandoning utilities and underground piping.
- Demolition and removal of structures
- Backfilling and securing wet wells, below grade tanks and open pits

Existing WWTPs and lift stations, that are not functional or are no longer needed once the new facilities are constructed, will be removed, demolished and backfilled. The known facilities in the project area are listed below. Their locations are shown on Figure 3-3.

- Corinth HDC LS
- Gulf View Development LS
- Harmony Hall LS
- Kelvin Avenue LS
- Palmiste Boulevard LS
- Pleasantville LS
- Pollonais Crescent #1 LS
- Pollonais Crescent #2 LS
- Retrench HDC (Hillcrest Gardens) LS
- Tarouba North LS
- Tarouba Heights LS
- Union Hall #1 LS
- Union Hall #2 LS
- San Fernando WWTP (some facilities will be re-used or left in place for future use)
- Gulf View Development WWTP
- Harmony Hall (eTeck) WWTP
- Marabella Secondary School WWTP
- Palmiste WWTP
- San Fernando Technical Institute WWTP
- Sunkist WWTP
- Westpark WWTP
- Corinth Housing Development Retention Pond



### 3.15.1 Demolition Process

Prior to demolition, removal or abandonment all earmarked structures will be released by WASA and all electrical, ventilation, process and plumbing services will be rerouted or shut off outside of the demolition area. Items identified for salvage will be delivered to a storage facility location specified by WASA. All other existing facilities intended to remain in-place that may be affected by the demolition process will be surveyed and recorded both before and after the demolition process. If necessary, any affected facility will be restored to its original condition. All existing facilities, utilities and equipment intended to remain will be maintained in service and protected from damage.

- Roadways, streets, walks and other facilities occupied or used by WASA and the public will not be closed or obstructed without permission from the relevant authorities.
- Relevant utility authorities will be notified prior to razing operations to allow for disconnection, removal or relocation of equipment serving existing facilities if necessary.
- Salvaged material and equipment to be retained shall be transported to a designated storage site. Materials to be salvaged include pumps, motors, standby generators, valves, hoists, fittings, and aluminum sheeting.

### 3.15.2 Demolition Operations

Demolition involves the removal of existing structures to a point below specified finish grade.

- Equipment and materials not scheduled to be salvaged will become property of Contractor and legally disposed of off-site.
- Wastewater and wastewater sludge from existing tanks will be drained via existing and newly constructed collection system, or if necessary, hauled to the San Fernando WWTP. Care will be taken so that all liquids are contained and properly treated.
- Demolition of existing structures will include superstructure, foundation, footings, piles, utility drains and other piping 450 mm below finished grade in landscaped areas, and 1 m below finished grade in pavement areas. Structures within influence zone of new structures will be completely demolished.
- Below grade structures that are abandoned in-place will have openings cut in the floors to provide for drainage.
- Utility drains and other piping will be plugged or capped.
- The site of the demolished structures will be graded to prevent ponding.

### 3.15.3 Removal Operations

These operations involve the removal of portions of existing structures or utilities to both above and below finish grade as required.

- Existing concrete, steel and masonry will be removed as required. Smooth, straight joint or cut line and cuts parallel with walls or floors will be employed. Cut and patch will be done in accordance with Contract specifications.
- Utilities and piping will be removed and plugged/ sealed permanently with steel cap, concrete plug or other approved method.



- Abandoned utilities and underground piping within influence zone of proposed underground piping and proposed structures will be removed.
- Temporary shoring and bracing will be provided in order to transfer loads of existing remaining construction from construction being removed where necessary.

### 3.15.4 Abandonment Operations

Abandonment is the removal of existing utilities from service, and involves full disconnection from other portions that are to remain in service. Portions of the utility that are being abandoned are removed from the influence zones of structures, manholes or underground piping, and piping ends are plugged or capped as necessary.

- Relevant underground utilities and piping will be selected for abandonment.
- Compatible caps for pressurized type piping will be provided. Thrust blocks for caps (unless piping has fully restrained joints) will be provided.
- Gravity type piping will be fitted with concrete plugs. Plugs will be thrust block standard concrete a minimum of 0.6 m thick.

### 3.15.5 Disposal

Sludge, debris, and other undesirable and unsalvageable material resulting from demolition operations will be disposed of to the nearest landfill site. Wastewater will be disposed of to the San Fernando wastewater treatment plant. All hazardous waste must be disposed of in accordance with the regulation and code requirements.

## 3.16 Demolition and Decommissioning of New San Fernando Wastewater Project

The project is designed for 2035 flows; however, the WWTP is likely to remain in service for many years beyond that date because the need for wastewater treatment will continue indefinitely. While equipment will need to be replaced over the course of time, concrete structures typically have a useful life in excess of 50 years. (The existing WWTP was constructed in the late 1960s and the concrete structures continue to meet their intended functions.) Future conditions that might affect the decommissioning decision are largely based on unknown factors; therefore, details of facility closure and decommissioning presented herein are limited. A decommissioning plan would be prepared in the future in the event that the plant or components of its infrastructure would be decommissioned.

Decommissioning of the wastewater treatment plant and its associated facilities would be executed in a manner consistent with relevant legislations and regulations at that time. This process would involve interaction with the jurisdictional regulatory agencies of Trinidad and Tobago. WASA would develop a detailed plan for site closure when that information is better understood.

The end use objective will affect the type of decommissioning undertaken. This may include:

- Alternate use.
- Abandon in place.
- Demolition and removal (i.e. the removal of buildings, equipment, and installed features).



- A combination thereof.

Elements of the decommissioning plan will include:

- Evaluation of decommissioning alternatives.
- Sequencing of activities.
- A strategy to identify and remediate disturbed areas.
- Details of the demolition and removal activities to be undertaken.
- Restoration and re-vegetation.

For safety of personnel and the environment, decommissioning activities of the proposed San Fernando WWTP will be implemented after operations have ceased and equipment has been properly deactivated. The Government of the Republic of Trinidad and Tobago (GORTT) will be notified when decommissioning is scheduled. A revised plan will be prepared and provided to GORTT when decommissioning is more imminent, but no less than 12 months before closure is planned.



## 4. Analysis of Alternatives

The objective of an analysis of alternatives is to describe reasonable alternatives to any project beginning with an assessment of the project siting options, through to an analysis of the technical and design consideration and ending with an assessment of a no action alternative. For this project, the overriding project goal is to reduce the pollution loading from the discharge of untreated or partially treated wastewater from homes, commercial, instructional and industrial entities in the San Fernando Catchment area. The goal of the project is to be realised through the following key project objectives:

- Connection of all point sources of discharge of wastewater from homes, commercial, institutional and industrial entities in the San Fernando catchment areas to a centralized sewer collection and treatment system.
- Establishment of an interconnected network of new and existing lateral sewers, trunk sewers, lines and lift stations that will serve as an integrated wastewater collection system.
- Upgrade of the San Fernando WWTP to have the capacity to effectively handle all of the wastewater treatment needs of the catchment area while using modern secondary and tertiary treatment technology to consistently produce an effluent quality that meets the standards for discharge to inland water courses in Trinidad and Tobago, and for reuse in agricultural injection or industrial end-uses.

Alternative measures to achieve these key project objectives are discussed below.

### 4.1 Wastewater Treatment Plant Location

The best location for the new San Fernando WWTP would be at the lowest elevation in the catchment so wastewater can be conveyed to the plant site by gravity and minimize the need for expensive pumping. In this case, locating the WWTP anywhere near the Gulf of Paria would meet this criterion.

Available sites along the Gulf are limited because the area within the San Fernando Project boundaries is highly developed. The existing San Fernando WWTP site is just north of the Ciperó River upstream of its discharge point to the Gulf of Paria. As will be described later in this Section, this site has sufficient land area to build the new WWTP while keeping the existing WWTP in service. The existing site has a number of major advantages over a new “greenfield site” elsewhere in the catchment. These advantages are:

- Major trunk lines serving San Fernando Proper terminate at this site.
- Location is adjacent to the Ciperó River resulting in a short outfall.
- Land is already owned by WASA.

### 4.2 Type of Collection System

Primary objectives of the project are protection of public health and safeguarding the environment. In this regard four alternative sewer systems were evaluated regarding their ability to adequately address these concerns. These are:

- Low Pressure System



- Vacuum System
- Small Gravity Diameter (SGD) System
- Conventional Gravity Sewer System

#### 4.2.1 Low Pressure System

There are two basic types, the Septic Tank Effluent Pump System (STEP) and the Grinder Pump system (GP)

##### 4.2.1.1 Septic Tank Effluent Pump System (STEP)

In a STEP system a grinder pump is installed in the existing septic tank. The pump forces the wastewater through a force main into either a larger diameter low pressure sewer and/or into a conventional gravity sewer. Modifications to the existing septic tanks would be required to accommodate the pump and the operation of the system would resemble that of a sump pump.

While this system has advantages in areas with difficult site conditions such as high water tables, undulating topography, sites with ground elevation lower than that of the main gravity sewer, and is also relatively cheaper than conventional gravity systems in low density development areas, it requires the operation and maintenance of the grinder pump at each household. This puts the responsibility of pump maintenance and operation upon the homeowner. This factor is viewed as a major drawback to the success of the STEP system in meeting environmental and health concerns of the project. If faulty septic tanks leak, this system will be prone to failure. This system is not sufficiently reliable and therefore eliminated from further consideration.

##### 4.2.1.2 Grinder Pump (GP) System

The GP system is similar to the STEP system except that the existing septic tank is removed and a self contained grinder pump complete with tanks is directly tied into the household's plumbing system. Wastewater is pumped directly into the low pressure sewer through a small diameter discharge pipe system.

Advantages to the system are similar to the STEP system in that it is suited to sites with high water tables, difficult topography, isolated areas and in cases where ground elevation is lower than that of the main sewer. It is also relatively cheaper than conventional gravity sewer systems. The disadvantage is that it requires each household to operate and maintain the grinder pump, and for this reason was considered prone to failure and not recommended for the project.

#### 4.2.2 Vacuum System

In a vacuum sewer system, the vacuum sewer lines operate under a vacuum pressure (i.e., 380mm to 625mm Hg) created by vacuum pumps located at the main vacuum station. The pressure differential between the atmospheric pressure and the vacuum in the sewer lines, forces open valves and draws the wastewater through the sewer lines.

Typically, domestic wastewater flows by gravity through individual service lines from as many as four homes into a sealed fibreglass chamber. As the wastewater level rises inside the chamber, increased pressure of air trapped inside activates valves causing wastewater to flow to the main vacuum station.





Vacuum pumps at the main vacuum station transfer the wastewater through a discharge force main to either a conventional gravity wastewater collection sewer and/or directly to the wastewater treatment facility.

This system is advantageous in areas of undulating topography, poor load bearing soils, with high ground water tables and in areas where property ground elevation is lower than that of the main gravity sewer. The system, however, is fairly complex, requires regular maintenance and is prone to failure. Disruption to the homeowner during installation and change-over of systems is relatively longer than for a conventional gravity sewer system. The vacuum sewer system was not recommended due to its operational complexity and maintenance requirements.

#### 4.2.3 Small Diameter Gravity (SDG) System

SDG systems utilize existing septic tanks as settling basins to remove grease, grit and other heavy solids. The supernatant from the septic tanks then flows into a small diameter sewer. Septic tanks need to be emptied at regular intervals. The main advantage of the SDG system is that it is comparatively less costly than conventional gravity sewer systems in terms of capital cost.

One disadvantage is that the SDG system would not achieve the project goals of public health protection and safeguarding the environment if existing septic tanks continue to leak. Many existing septic tanks need to be completely rebuilt and made watertight if the SDG system is to be able to achieve the objectives of the project. Septic tanks also need to be emptied at regular intervals to reduce the risk of overflow and increased threat to public health and environmental pollution. Septage removed from the septic tanks needs to be treated either at a septage treatment facility or the proposed new WWTP. SDG does not reduce the requirement for treatment it merely defers it.

Assuming that SDG is adopted, all existing leaking septic tanks would need to be replaced or repaired, and maintained in optimum condition if the system is to be successful. If WASA was to undertake the replacement, inspection and maintenance of septic tanks, then capital costs of the SDG system would likely be more than that of the conventional gravity system. For these reasons the SDG system was not recommended for this project.

#### 4.2.4 Centralized Conventional Gravity Sewer System

The conventional gravity wastewater collection system collects all wastewater using individual service connection piping into a lateral sewer and eventually into a main sewer. If the WWTP is located at the lowest point in the collection system, all flows could be conveyed by gravity; however, this is usually not practical and flows collected in low lying areas would need to be pumped. The main advantage of the system is that the public health and environmental protection issues will be safeguarded. One disadvantage is the longer disruption period during construction due to deeper trench construction and the relatively higher capital costs.

The conventional gravity sewer system is the logical choice for the San Fernando Project from a reliability viewpoint and the ability to meet the stated objectives of the project. The project terms of reference include tying in existing conventional gravity sewer systems within the project boundaries, which would have added difficulty if a different method of collection system was implemented. The



conventional gravity sewer system is also the preferred choice of WASA. Consequently this system was selected as the preferred option for the wastewater collection system for San Fernando.

### 4.3 Selection of Wastewater Treatment System

Several process options for treating liquids and solids streams have been evaluated. These options are summarized in the following sections.

#### 4.3.1 Liquids Treatment Process Options

The new San Fernando WWTP will need to include processes capable of achieving effluent quality that will meet EMA requirements for discharge to an inland water course, the Ciperó River. In addition to providing secondary treatment, WASA decided to provide tertiary filtration and high level disinfection of the secondary effluent to reclaim the water for reuse rather than discharge to the river, if appropriate users can be identified. One example would be irrigation water for the Picton Mega Farm. Options for treating the wastewater liquids are described in the following sections.

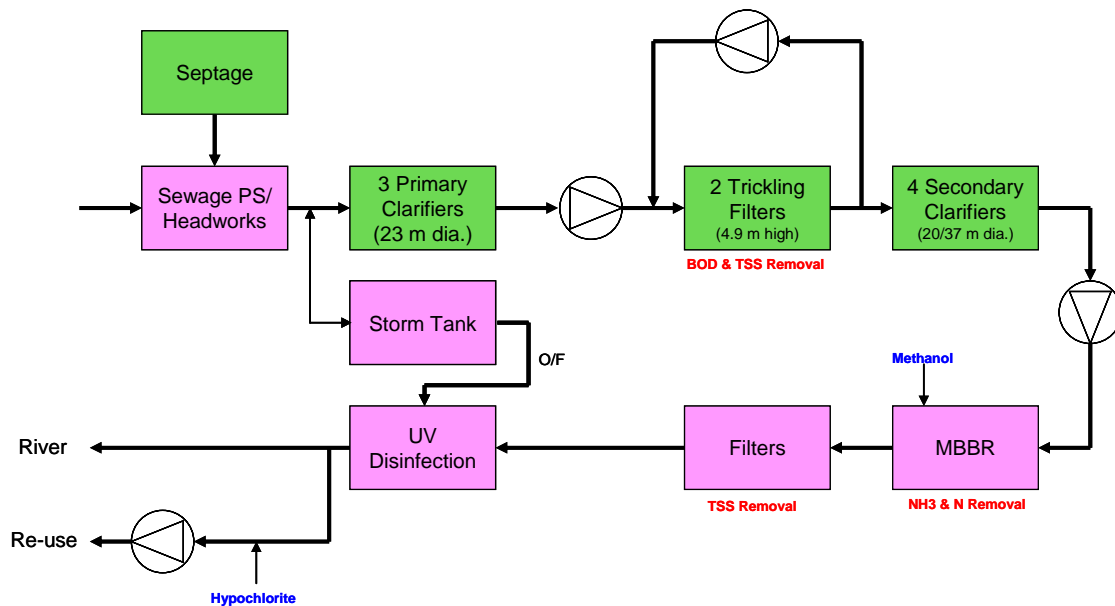
##### 4.3.1.1 Option L1 - Trickling Filter and Moving Bed Biofilm Reactor

This option uses trickling filters for BOD removal and a moving bed biofilm reactor (MBBR) for nitrogen removal.

The raw wastewater is initially pumped to the headworks, which comprises 6 mm screens and a grit removal system. Septage hauled to the site would be screened and then discharged into the influent pumping station.

This option continues to use the existing primary clarifiers, although a third clarifier is required for treating wet weather events. Flow in excess of the capacity of the primary clarifiers and secondary treatment system is diverted to a storm water tank. This temporarily stores the excess wastewater until the plant has sufficient capacity to treat the stored wastewater.

This option continues to use the trickling filter process for BOD removal; however, the rock media is replaced with plastic media and the height of the trickling filters increased. To improve performance, effluent from the trickling filter is recycled to the trickling filter inlet. Two additional secondary clarifiers are required for the higher design flow. Figure 4-1 is a flow schematic for Option L1. New process units are indicated in pink. Existing, modified, or expanded processes are green.



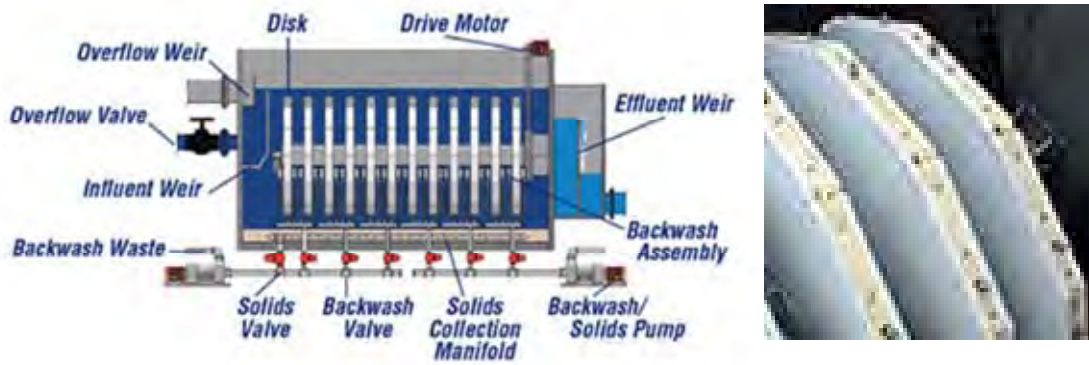
**Figure 4-1 Flow Schematic of Option L1**

To meet the requirements for ammonia and nitrogen removal, another biological treatment stage is required. In this option a MBBR system is used for both nitrification (ammonia oxidation) and denitrification (nitrogen removal). A MBBR is a pure biofilm process without sludge recirculation. The nitrifying and denitrifying bacteria attach to the media, which are available in a variety of materials, shapes, and sizes. Typically media fill volumes are between 25% and 65% of the total tank volume.

The MBBR is divided into two zones: the first zone is aerated for nitrification, and the second zone mixed with submersible mixers. Screens are located at the end of each zone to retain the media and allow the effluent wastewater to continue downstream.

Denitrification requires a source of carbon for the denitrifying bacteria. In a conventional WWTP, the BOD in the raw wastewater is used. However, with the denitrifying MBBR downstream of the trickling filters and the nitrifying MBBR, most of the BOD will already have been removed. Therefore it is necessary to add an external carbon source to the denitrifying MBBR. Methanol is the external carbon source typically used, and is appropriate for Trinidad, given the country's large methanol production capabilities.

To remove solids generated in the MBBR, and to produce an effluent with a low TSS concentration suitable for reuse, a filtration process is required. In this option cloth-media filtration is used, as it is a low-cost method of providing filtration and meets North American regulations for producing reclaimed water. In this process the water passes through a series of rotating cloth-covered disks (Figure 4-2) into a central collection header. The filtered effluent exits the central header via a chamber equipped with an overflow. Backwashing is conducted in-situ while the discs are rotating. A series of suction shoes are used to vacuum the solids off the surface of the disk.

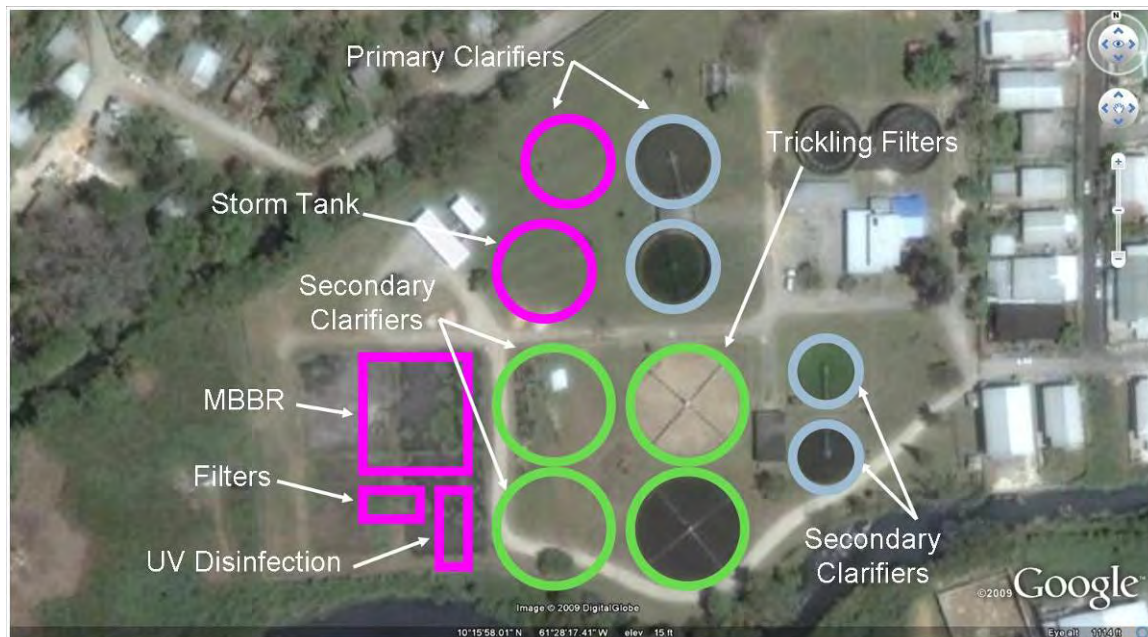


**Figure 4-2 Cloth Media Filter (Courtesy of Aqua-Aerobic Systems)**

To comply with the EMA’s Faecal Coliform requirement, the treated effluent is disinfected with ultraviolet (UV) light. The use of filters upstream of the UV disinfection means that the influent to the UV disinfection system has a low TSS and a high UV transmittance. This means that a smaller UV disinfection system can be provided, minimizing energy and lamp replacement costs.

Before discharging to the Ciperó River, some of the treated effluent will be withdrawn for reuse within the plant. To meet the stringent Faecal Coliform requirements for agricultural reuse, the reuse water will be chlorinated using sodium hypochlorite.

Figure 4-3 provides a conceptual site layout for Option L1. Units shaded in blue are existing, those in green are upgrades of existing units, and those in pink are new.



**Figure 4-3 Conceptual Site Layout of Option L1**

The advantages and disadvantages of this option are summarized in Table 4-1.



**Table 4-1 Advantages and Disadvantages of Option L1**

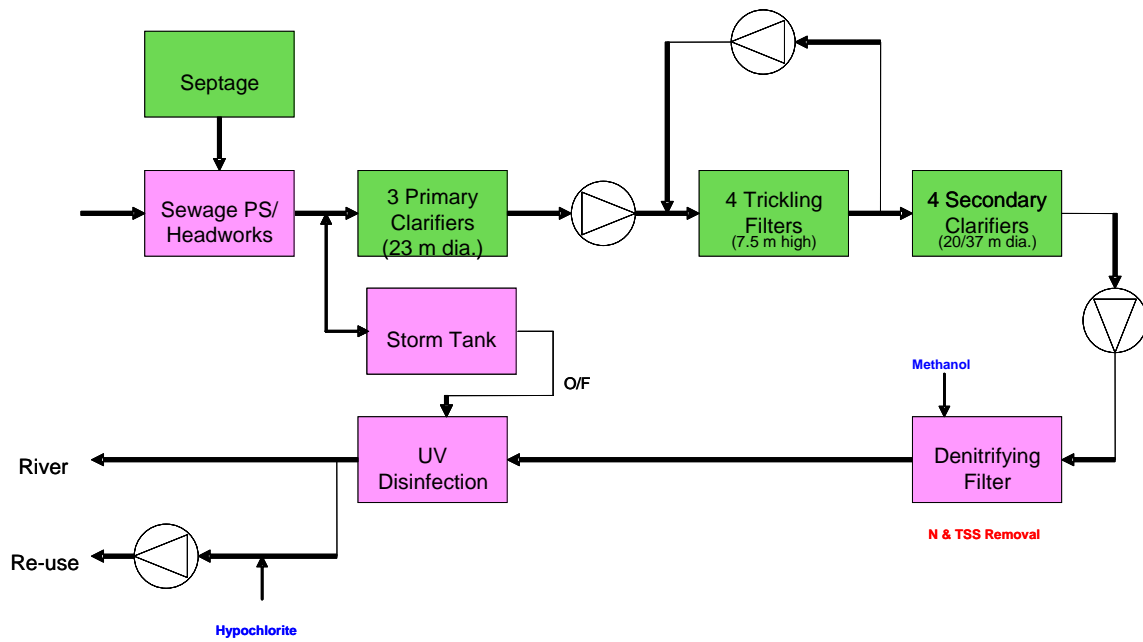
Advantages	Disadvantages
<ul style="list-style-type: none"><li>• Uses existing structures to a large extent.</li><li>• Multi-barrier treatment train.</li></ul>	<ul style="list-style-type: none"><li>• Need to take a trickling filter off-line for upgrade, thus compromising treatment performance.</li><li>• Significant layout and pipe routing issues.</li><li>• Difficult flow splitting between the small and large secondary clarifiers.</li><li>• Methanol safety and O&amp;M cost.</li><li>• Three major pumping stations.</li><li>• Risk of filter flies in this residential area.</li></ul>

*4.3.1.2 Option L2 - Trickling Filter and Denitrifying Filter*

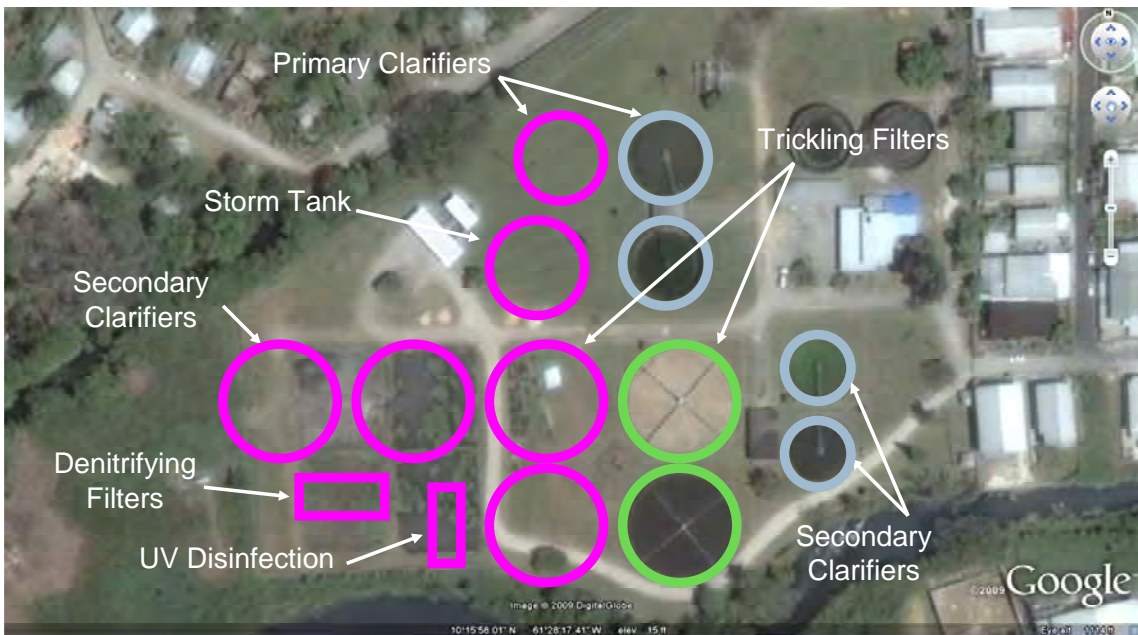
This option follows the same approach as Option L1 for raw wastewater pumping, preliminary treatment in the headworks, septage management, primary clarification, storm water management, UV disinfection, and chlorination.

However, unlike Option L1, this option uses the trickling filters for both BOD removal and ammonia oxidation. Four tall plastic media biotowers are required, two of which use the existing trickling filter structures and two will be new. As with Option L1, a recirculation system is employed for the trickling filters and additional secondary clarifier capacity is required.

Like Option L1, denitrification and filtration is required. However, in Option L2, denitrification and filtration is combined into one process: denitrifying sand filtration. Methanol is added to the filters for the denitrification process. Figure 4-4 and Figure 4-5 summarize Option L2.



**Figure 4-4 Flow Schematic of Option L2**



**Figure 4-5 Conceptual Site Layout of Option L2**

The advantages and disadvantages of this option are summarized in Table 4-2.



**Table 4-2 Advantages and Disadvantages of Option L2**

Advantages	Disadvantages
<ul style="list-style-type: none"><li>• Uses existing structures to a large extent.</li><li>• Can stage construction off-line to minimize loss of treatment capacity.</li></ul>	<ul style="list-style-type: none"><li>• Significant layout and pipe routing issues.</li><li>• Difficult flow splitting between the small and large secondary clarifiers.</li><li>• Methanol safety and O&amp;M cost.</li><li>• Risk of filter flies in this residential area.</li><li>• Tall biotowers would be visually obtrusive in this residential area.</li></ul>

*4.3.1.3 Option L3 – Activated Sludge Plant*

This option follows the same approach as Options 1 and 2 for raw wastewater pumping, preliminary treatment in the headworks, septage management, UV disinfection, and chlorination; however, unlike Options 1 and 2, this option does not require primary clarifiers. The existing primary clarifiers are used as stormwater storage tanks.

None of the existing secondary treatment plant (trickling filters and secondary clarifiers) are used in Option L3. A new activated sludge plant is constructed for combined BOD, ammonia, and nitrogen removal.

To produce an effluent with a low TSS concentration suitable for reuse, a filtration process is required. As with Option L1, cloth-media filtration is employed.

Figure 4-6 and Figure 4-7 summarize Option L3.

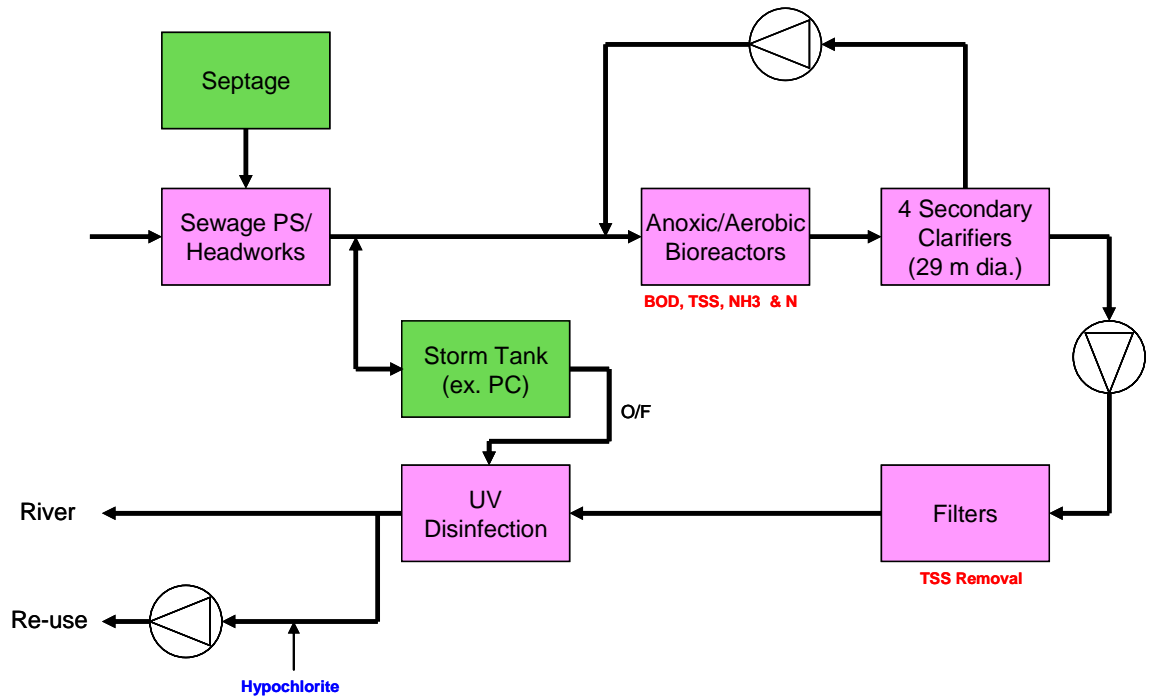


Figure 4-6 Flow Schematic of Option L3

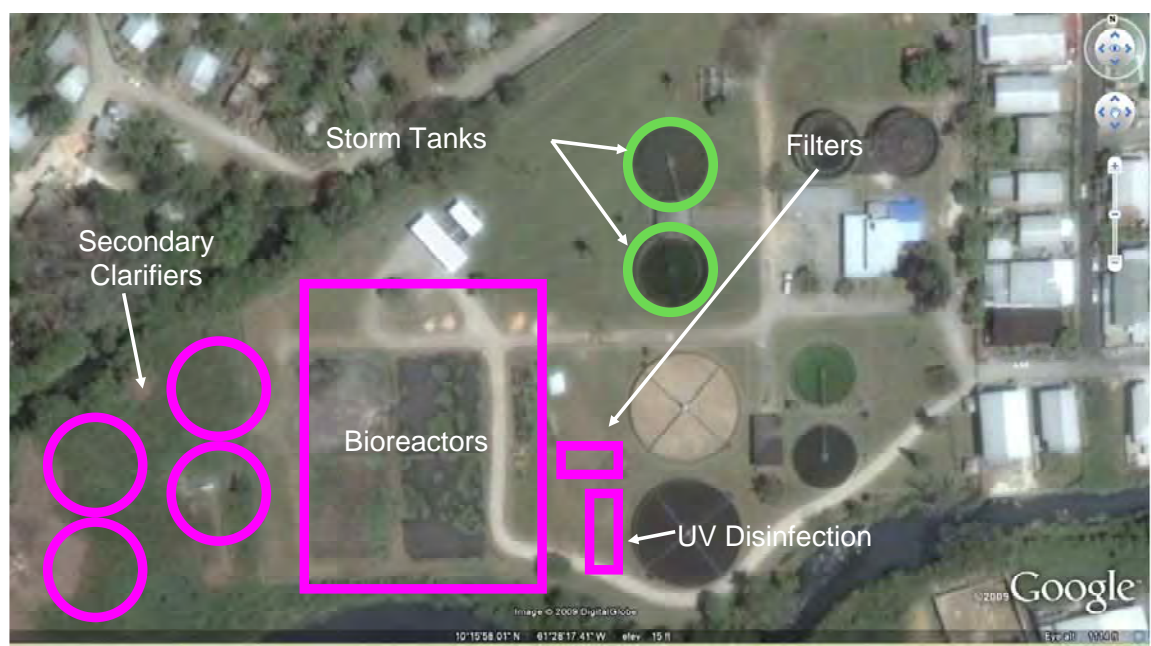


Figure 4-7 Conceptual Site Layout of Option L3



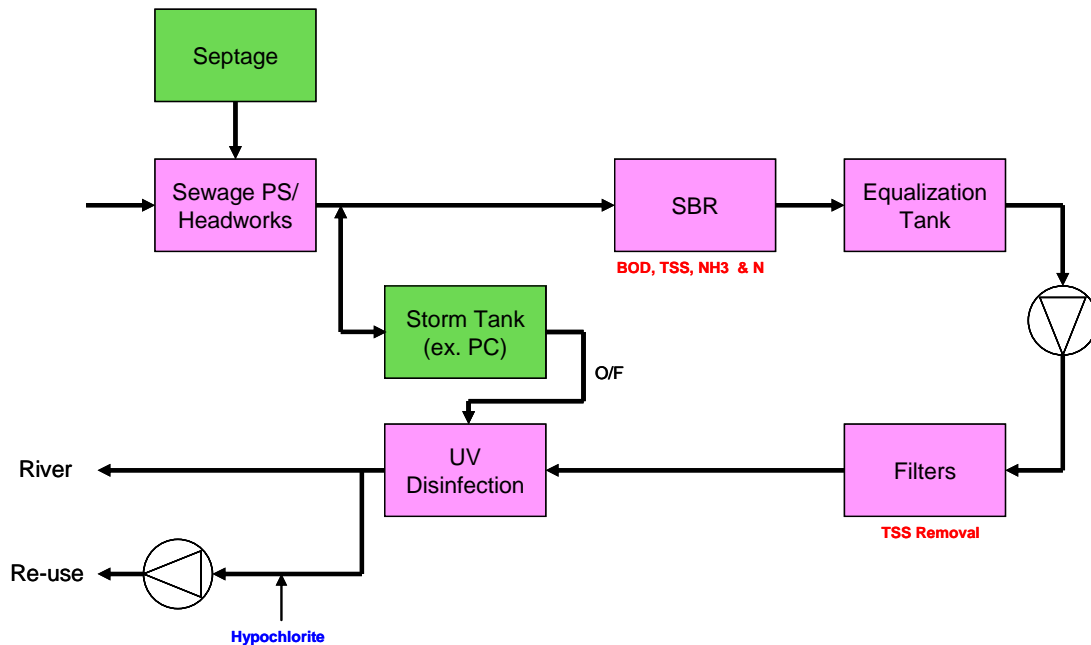
The advantages and disadvantages of this option are summarized in Table 4-3.

**Table 4-3 Advantages and Disadvantages of Option L3**

Advantages	Disadvantages
<ul style="list-style-type: none"> <li>• New plant can be built off-line, minimizing disruption to existing operation.</li> <li>• WASA familiar with operating this process.</li> <li>• Proven in Trinidad.</li> <li>• No methanol.</li> <li>• Can demolish existing structures for future expansion.</li> </ul>	<ul style="list-style-type: none"> <li>• Predominantly new structures.</li> </ul>

*4.3.1.4 Option L4 – Sequencing Batch Reactor*

Option L4 is identical to Option L3 except that sequencing batch reactors (SBRs) are used for secondary treatment rather than flow-through activated sludge. SBRs are an activated sludge process that operates in a batch mode. For a plant of this size, it would be typical to provide four SBR tanks to minimize the size of the downstream equalization tank. SBRs can be provided in a number of shapes including circular and rectangular with common wall construction. Figure 4-8 and Figure 4-9 summarize Option L4.



**Figure 4-8 Flow Schematic of Option L4**



**Figure 4-9 Conceptual Site Layout of Option L4**

The advantages and disadvantages of this option are summarized in Table 4-4.

**Table 4-4 Advantages and Disadvantages of Option L4**

Advantages	Disadvantages
<ul style="list-style-type: none"> <li>• Relatively compact plant.</li> <li>• No methanol required.</li> <li>• Modular and therefore easy to expand, although there is not much room for expansion at the site.</li> </ul>	<ul style="list-style-type: none"> <li>• Predominantly new structures.</li> <li>• Process not familiar to WASA.</li> <li>• Not proven in Trinidad.</li> </ul>

#### 4.3.1.5 Option L5 – Membrane Bioreactor

This option is similar to the activated sludge option, but it uses membranes rather than clarifiers for solids separation. Since the bioreactors can run at higher mixed liquor concentrations, they are smaller than those in the activated sludge option. To protect the membranes from fouling, two-stage screening is provided; the second stage screens have perforations of 1 to 2 mm. The filtering effect of the membranes eliminates the need for separate cloth-media filters. Although the membranes filter the bacteria, it is common practice to disinfect MBR effluent, and hence a UV disinfection plant is provided.

Figure 4-10 and Figure 4-11 summarize Option L5.

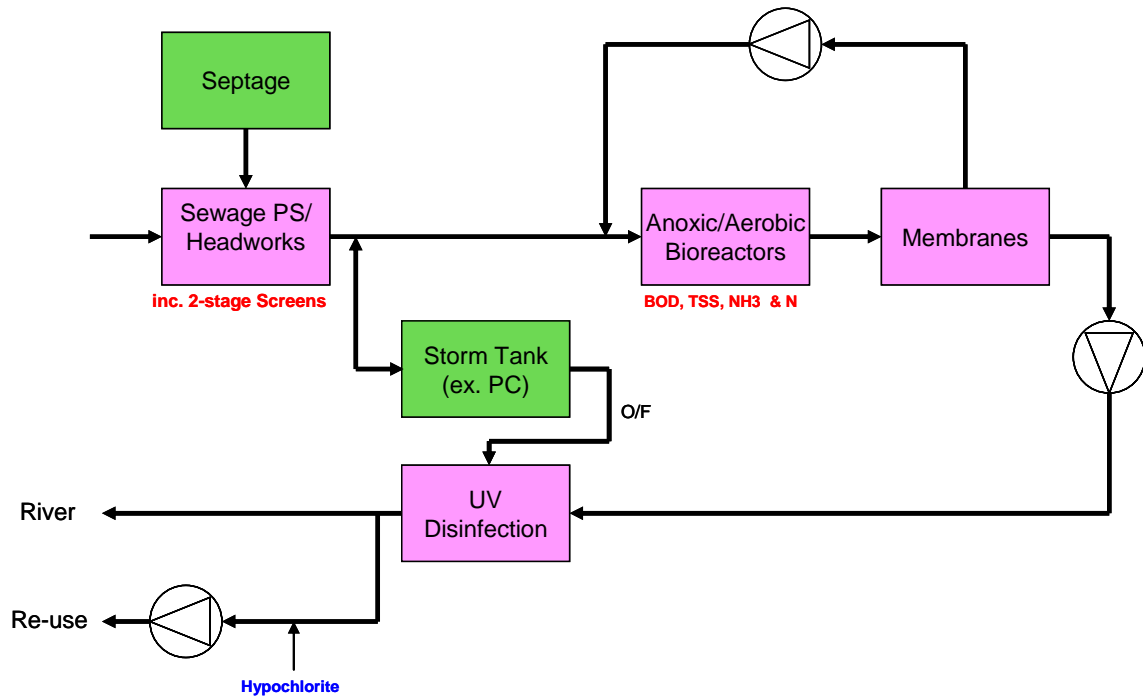


Figure 4-10 Flow Schematic of Option L5

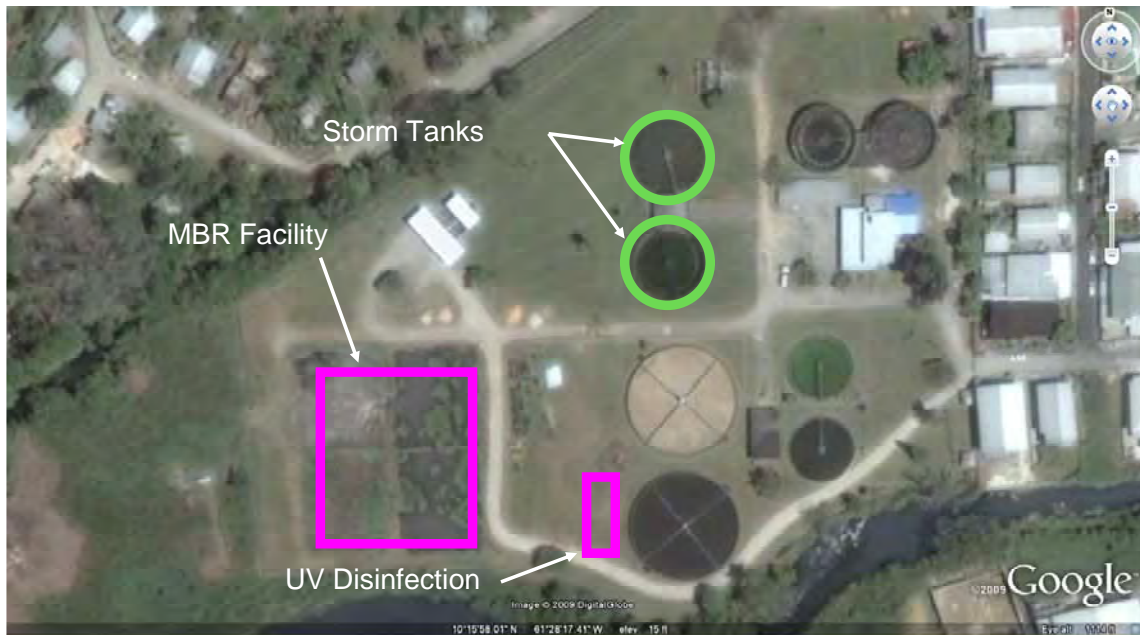


Figure 4-11 Conceptual Site Layout of Option L5

The advantages and disadvantages of this option are summarized in Table 4-5.

**Table 4-5 Advantages and Disadvantages of Option L5**

Advantages	Disadvantages
<ul style="list-style-type: none"> <li>• Compact plant.</li> <li>• Very high quality of effluent, likely to be better than what is actually required.</li> </ul>	<ul style="list-style-type: none"> <li>• Predominantly new structures.</li> <li>• Equipment-intensive.</li> <li>• Higher equipment redundancy requirements.</li> <li>• Chemicals for membrane cleaning.</li> <li>• High energy usage.</li> <li>• Membrane replacement costs.</li> </ul>

### 4.3.2 Comparison of the Liquid Stream Options

The five options described above were presented to WASA at a workshop. A list of key evaluation criteria was developed at the workshop, together with appropriate weighting for each criterion. The criteria used for evaluation of the options are described in Table 4-6.

**Table 4-6 Evaluation Criteria**

Criteria	Description
<b>Technical</b>	
Proven Reliability	Ability to reliably produce the required effluent quality, with an emphasis on being proven in Trinidad and Tobago.
Robustness	Ability to respond to varying conditions, such as shock loads.
Flexibility	Ability to respond to varying operational requirements, such as taking unit out of service, and redundancy requirements
Space Requirements	Footprint
Expandability	Ease with which the process can be modularized and expanded
Constructability	Ease of construction with an emphasis on the effects of construction on the existing operating plant.
<b>Operational</b>	
Ease of Operations	The ability of the process to be easily operated.
Ease of Maintenance	Refers to how equipment-intensive the process is.
Operator Safety	Predominantly refers to chemicals and chemical handling
Operator Environment	The working environment to which the operational staff are exposed
<b>Environmental &amp; Aesthetics</b>	
Visual Impact	The visual impact of the structures on the neighbouring community
Noise	Relative noise of the process
Odour/Dust	Odour and dust generated as part of normal operation, including dust from vehicle access.
<b>Economic Criteria</b>	
Relative Construction Cost	Generic comparison of capital cost
Relative O&M Cost	Predominantly refers to electrical power costs and chemical costs



Each criterion was given a rating from 1 to 5 (with 5 being the best) and a weighting of 1 to 5 (with 5 being the most important).

Table 4-7 summarizes the evaluation of the five options.

**Table 4-7 Rating Table of Options**

	Weighting (1 to 5)	Option L1 TF+MBBR+F	Option L2 TF+DF	Option L3 AS	Option L4 SBR	Option L5 MBR
<b>Technical</b>						
Proven Reliability	5	4	3	5	3	2
Robustness	5	2	3	5	5	1
Flexibility	4	1	3	5	5	5
Space Requirements	2	4	3	3	3	5
Expandability	3	1	1	5	5	5
Constructability	2	1	3	5	5	5
<b>Operational</b>						
Ease of Operation	4	2	3	5	5	1
Ease of Maintenance	4	2	3	5	4	1
Operator Safety	4	1	1	5	5	3
Operator Environment	2	1	1	4	4	5
<b>Environmental &amp; Aesthetic</b>						
Visual impact	3	4	2	4	4	5
Noise	4	3	5	2	2	1
Odour/ Dust	4	3	3	5	5	5
<b>Subtotal</b>		<b>105</b>	<b>125</b>	<b>209</b>	<b>195</b>	<b>139</b>
<b>Economic Criteria</b>						
Relative Construction Cost	5	5	3	3	4	1
Relative O&M Cost	4	3	2	3	3	1
<b>Subtotal</b>		<b>37</b>	<b>23</b>	<b>27</b>	<b>32</b>	<b>9</b>
<b>Overall Weighed Scoring as a Parentage of the Maximum Possible Score</b>		<b>47%</b>	<b>54%</b>	<b>90%</b>	<b>84%</b>	<b>59%</b>

The option rating, which takes into account issues specific to the San Fernando site; indicate that the activated sludge plant and the sequencing batch reactor plant are the most appropriate for San Fernando. The activated sludge plant has a slightly better rating than the SBRs.

For a publically-owned authority like WASA, the main issue with SBRs is related to procurement. SBRs are marketed as an overall system by equipment suppliers who provide the process design



(including tank dimensions), the aeration system (blowers and fine bubble diffusers, or floating surface aerators) decanters, waste activated sludge pumps, controls and instrumentation. In a conventional design-bid-build contract, as in the San Fernando WWTP, the design engineer would need to select the SBR system from a particular vendor, and then design the WWTP around this vendor's process. When the WWTP contract is tendered, the bidders have only the one SBR supplier that they can procure equipment from. This limits competition, and does not provide a transparent approach in the tendering process. There are methods to alleviate this issue, such as competitive tendering for the SBR system in advance of design. However, this approach extends the design period, and would also require that WASA issue a purchase order to an SBR supplier prior to the design. In summary, although SBRs are an excellent technology for wastewater treatment, comparable to activated sludge, they are not commonly used for large publically-owned design-bid-build wastewater treatment plants. SBRs are far more common in privately-owned wastewater treatment plants (e.g. industrial plants) or in design-build projects. The SBR system, although ranked highly, is therefore not recommended in this case.

For the San Fernando WWTP, it is recommended that the activated sludge process be used. The activated sludge system had the highest rating, it is a proven technology in Trinidad, and WASA is familiar with its operation and maintenance requirements.

Having selected the activated sludge system for San Fernando WWTP, the method of bioreactor aeration must be chosen. The two most popular methods of aeration are slow-speed surface aeration and fine bubble diffused aeration.

A conceptual design for both a surface aeration plant and a fine bubble aeration plant has been prepared. Each is described in detail below.

The surface aeration plant would be similar to the system already used by WASA, at Beetham. It would comprise bioreactors, with anoxic mixers, four recycle pumps, and two-speed surface aerators. To minimize noise and spray from the surface aerators, a tank freeboard of 1 m would be provided.

The fine bubble plant would have the same overall reactor volume as the surface aerator plant, but would be divided into different numbers of reactors than the surface aeration plant. Complete replacement of all fine bubble diffusers in a tank is typically conducted every five to seven years. In addition, emptying of each tank once a year for inspection and replacement of broken diffusers and air piping is standard practice. Each reactor would include anoxic mixers, and internal recycle pumps. A blower building with five positive displacement blowers (four on duty, one standby) would be provided. The blowers would be equipped with acoustic enclosures. In addition, the blower building would have acoustic cladding to minimize nuisance noises affecting nearby residents. The fine bubble plant would have deeper tanks than the fine bubble plant for efficient aeration.

A cost comparison of the two options is provided in the Table 4-8.

**Table 4-8 Conceptual Cost Comparison of Surface Aeration and Fine Bubble Aeration**

	Surface Aeration	Fine Bubble
<b>Capital Cost</b>		
Structural/Building	TT\$ 47 M	TT \$46 M
Process Equipment	TT \$20 M	TT \$25 M
Electrical/I&C	TT \$6 M	TT \$6 M
<b>Total</b>	<b>TT \$73 M</b>	<b>TT \$77 M</b>
<b>O&amp;M Cost</b>		
Aeration Power <sup>2</sup>	TT \$23 M	TT \$20 M
Additional Pumping Power	-	TT \$0.6 M
Diffuser Replacement	-	TT \$3 M
<b>Total</b>	<b>TT \$23</b>	<b>TT \$23.6 M</b>
<b>Present Value <sup>1</sup></b>	<b>TT \$ 96 M</b>	<b>TT \$ 100.6 M</b>

**Notes:**

1. PV based on discount rate of 4% over 25 years.
2. Based on TT\$ 0.396/kWh
3. These costs are for comparison only, and do not include contractor mark-ups, contingency, taxes, engineering etc.

The above analysis shows that the main capital cost difference between the two options is the equipment cost. This is because all of the equipment (except the aeration equipment) for fine bubble is in triplicate rather than in duplicate. Nonetheless, the present worth for the two systems is not significantly different. Based on discussions with WASA, it was decided to use fine bubble aeration mainly because it was considered to be better suited for the site with nearby residential developments.

### 4.3.3 Solids Treatment Process Options

Residuals produced at the new WWTP will include screenings, grit, and waste solids from the activated sludge process. Screenings and grit will be washed, dewatered, and then deposited in bins for hauling to and disposing of the materials at landfill.

The following solids unit processes are typically used for treating waste solids produced by activated sludge systems:

- Thickening
- Dewatering
- Solar drying
- Lime stabilization
- Composting
- Aerobic Digestion
- Storage

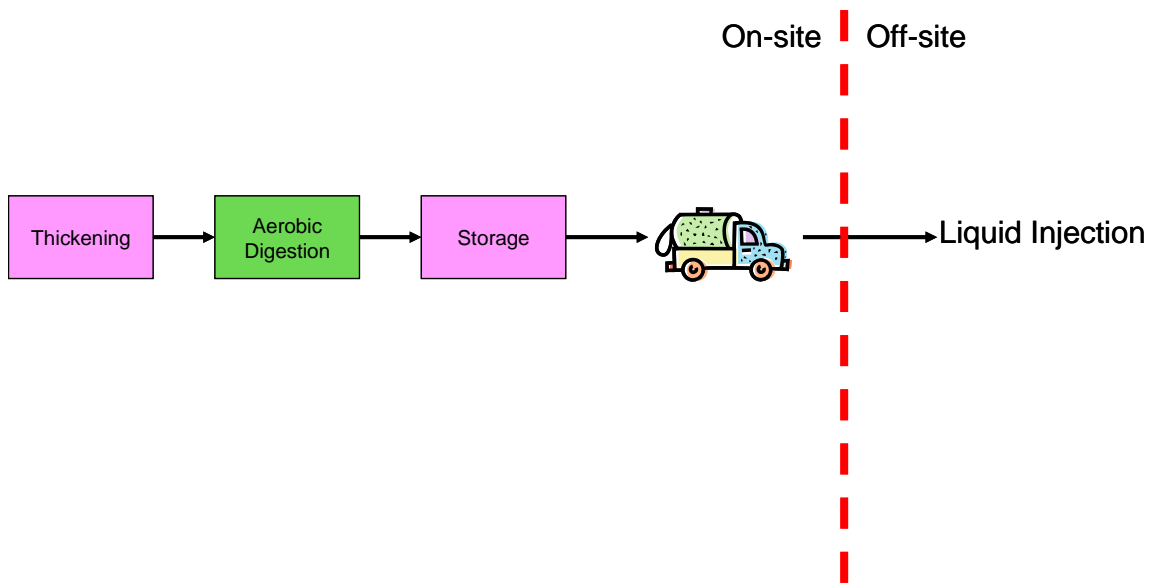
A series of solids stream treatment options have been developed using one or more of the above technologies. These options are appropriate for activated sludge plants without primary clarifiers, and hence do not include anaerobic digesters, which is the stabilisation process currently used at the existing WWTP where primary solids are available. The solids stream options are as follows:



- Option S1 – Aerobic Digestion and Liquid Disposal
- Option S2 – Aerobic Digestion and Cake Disposal
- Option S3 – Lime Stabilization
- Option S4 – Composting
- Option S5 – Solar Drying

#### 4.3.3.1 Option S1 – Aerobic Digestion and Liquid Disposal

Option S1 involves thickening of the waste activated sludge, aerobic digestion, on-site storage and eventual off-site reuse of the liquid biosolids by sub-surface injection on agricultural land. In this option the existing anaerobic digesters are reused as aerobic digesters (or storage tanks). Figure 4-12 summarizes Option S1.



**Figure 4-12 Schematic of Option S1**

The advantages and disadvantages of this option are summarized in Table 4-9.

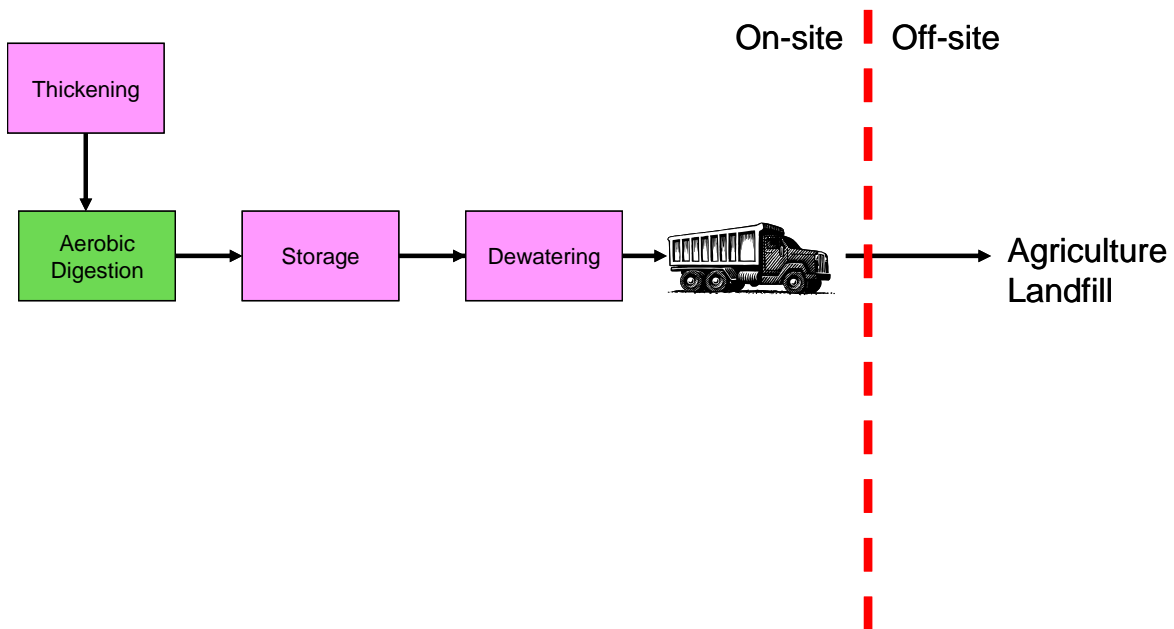


**Table 4-9 Advantages and Disadvantages of Option S1**

Advantages	Disadvantages
<ul style="list-style-type: none"> <li>Minimal number of treatment processes, making for easy operation and maintenance.</li> <li>Uses existing anaerobic digesters as aerobic digesters or storage tanks.</li> <li>Widely used in Trinidad.</li> </ul>	<ul style="list-style-type: none"> <li>Liquid transportation off-site. Means large number of trucks driving through residential areas and high hauling costs.</li> <li>Liquid injection may be an issue during the rainy season.</li> <li>Only one outlet for the product: agriculture.</li> </ul>

*4.3.3.2 Option S2 – Aerobic Digestion and Cake Disposal*

Like Option S1, Option S2 involves thickening of the waste activated sludge and aerobic digestion. However, the digested solids are dewatered to produce a cake before being transported off-site. The cake can be disposed to landfill or beneficially reused in agriculture. Figure 4-13 summarizes Option S2.



**Figure 4-13 Schematic of Option S2**

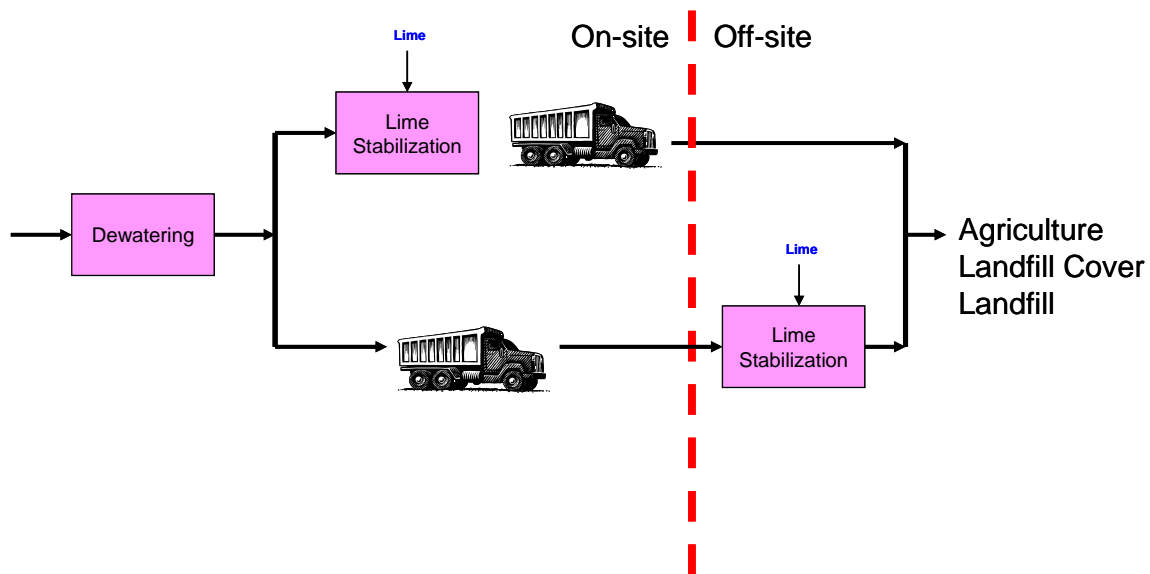
The advantages and disadvantages of this option are summarized in Table 4-10.

**Table 4-10 Advantages and Disadvantages of Option S2**

Advantages	Disadvantages
<ul style="list-style-type: none"> <li>• Uses existing anaerobic digesters as aerobic digesters or storage tanks.</li> <li>• Cake transportation minimizes traffic through residential areas and minimizes hauling costs.</li> <li>• Two outlets: Agriculture and landfill.</li> </ul>	<ul style="list-style-type: none"> <li>• Only one outlet for beneficial reuse: agriculture.</li> </ul>

*4.3.3.3 Option S3 – Lime Stabilization*

In Option S3, the waste activated sludge is dewatered to produce an un-stabilized cake. The cake is then stabilized with lime, at a lime stabilization plant, either on-site or off-site. The product of the stabilization process can be used for agriculture (in areas where low pH soils are an issue), for landfill cover, or simply disposed of at a landfill. Figure 4-14 summarizes Option S3.



**Figure 4-14 Schematic of Option S3**

The advantages and disadvantages of this option are summarized in Table 4-11.

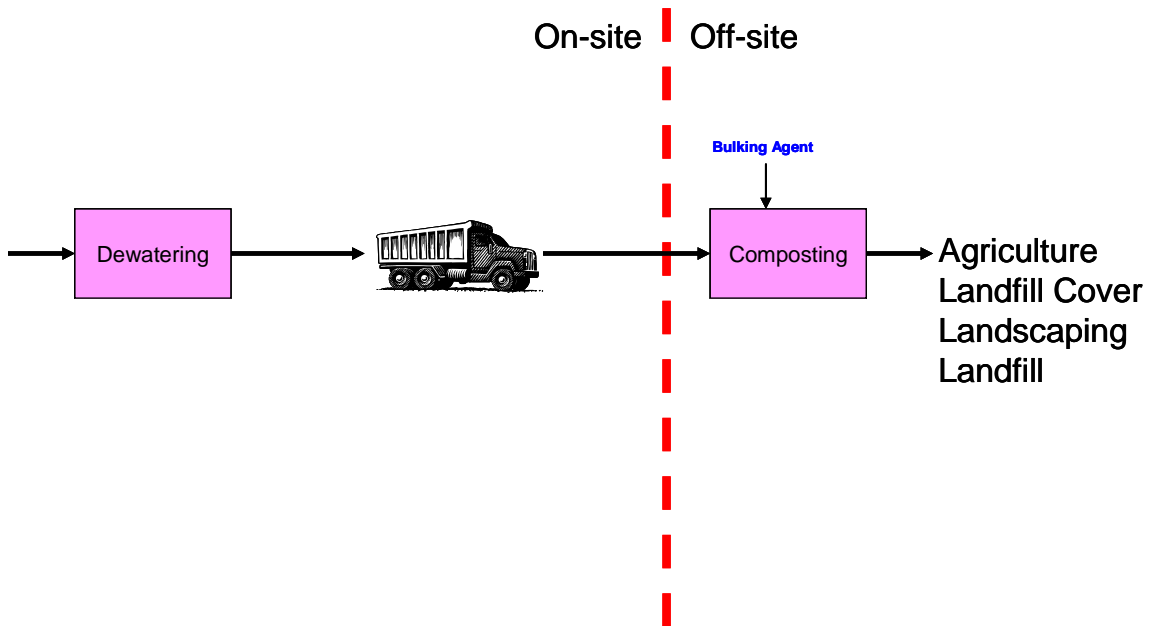


**Table 4-11 Advantages and Disadvantages of Option S3**

Advantages	Disadvantages
<ul style="list-style-type: none"> <li>• Cake transportation minimizes traffic through residential areas and minimizes hauling costs.</li> <li>• Two potential outlets for beneficial reuse: Agriculture and landfill cover.</li> </ul>	<ul style="list-style-type: none"> <li>• Additional site that needs to be operated and maintained, if lime stabilizing is located off-site.</li> <li>• Does not use existing digesters.</li> <li>• Lime handling can be an operational challenge, as well as a safety concern.</li> <li>• Relies on a chemical (lime) to operate.</li> <li>• Cost of lime.</li> </ul>

*4.3.3.4 Option S4 – Composting*

In Option S4, the un-stabilized solids from the WWTP are dewatered to a cake, and then transported off-site for composting. On-site composting is not feasible because of the large area required. A bulking agent, such as wood chips, needs to be added to the cake for composting. The compost can be beneficially reused in agriculture, for landfill cover and landscaping, or can simply be disposed of at a landfill. Figure 4-15 summarizes Option S4.



**Figure 4-15 Schematic of Option S4**

The advantages and disadvantages of this option are summarized in Table 4-12.

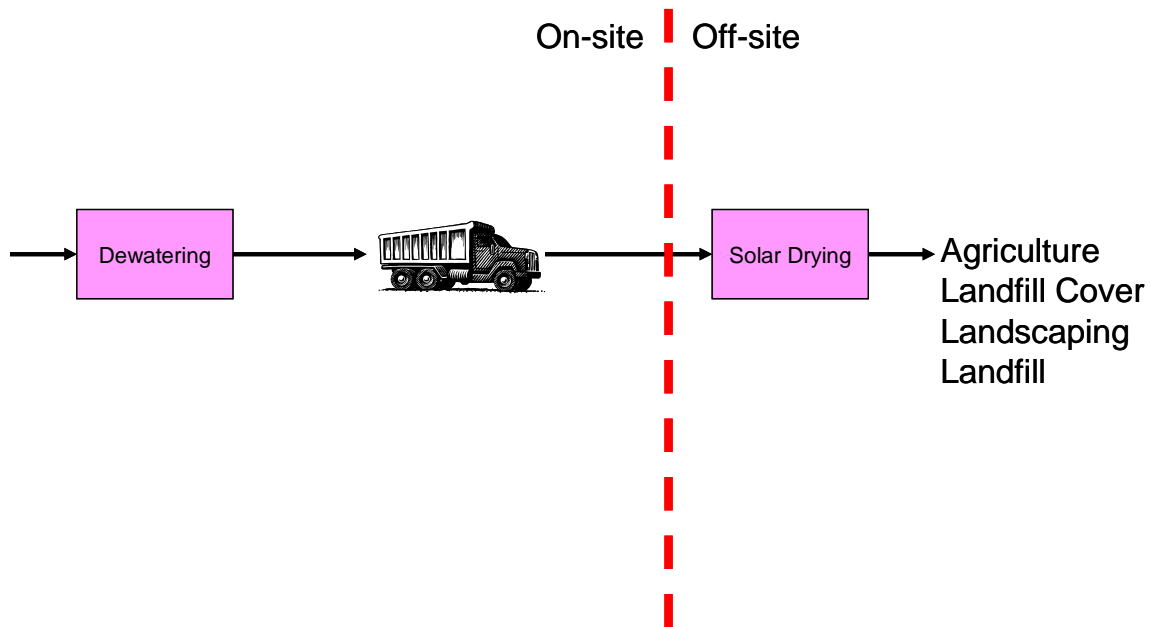


**Table 4-12 Advantages and Disadvantages of Option S4**

Advantages	Disadvantages
<ul style="list-style-type: none"> <li>• Cake transportation minimizes traffic through residential areas and minimizes hauling costs.</li> <li>• Three potential outlets for beneficial reuse: Agriculture, landfill cover, and landscaping.</li> <li>• Potential to run the composting at a SWMCOL landfill site.</li> </ul>	<ul style="list-style-type: none"> <li>• Additional site that needs to be operated and maintained, since composting would be located off-site.</li> <li>• Does not use existing digesters.</li> <li>• Relies on a bulking agent to work.</li> </ul>

*4.3.3.5 Option S5 – Solar Drying*

Like Option S4, the un-stabilized solids from the WWTP are dewatered to a cake, and then transported off-site. However, rather than composting, the cake is stabilized and dried by the sun in greenhouses. On-site solar drying is not feasible because of the large area of greenhouses required. The dried product can be beneficially reused in agriculture, for landfill cover and landscaping, or can simply be disposed of at a landfill. Figure 4-16 summarizes Option S5.



**Figure 4-16 Schematic of Option S5**

The advantages and disadvantages of this option are summarized in Table 4-13.



**Table 4-13 Advantages and Disadvantages of Option S5**

Advantages	Disadvantages
<ul style="list-style-type: none"> <li>• Cake transportation minimizes traffic through residential areas and minimizes hauling costs.</li> <li>• Three potential outlets for beneficial reuse: Agriculture, landfill cover, and landscaping.</li> <li>• Potential to run the drying operation at a Mega Farm site.</li> </ul>	<ul style="list-style-type: none"> <li>• Additional site that needs to be operated and maintained, since drying would be located off-site.</li> <li>• Does not use existing digesters</li> </ul>

**4.3.4 Comparison of the Solids Stream Options**

The five options described above were presented to WASA at a workshop. The same evaluation criteria that were used for the liquids stream options were used for the solids stream options; however, the weighting procedure was different to reflect the different priorities involved in solids management.

As with the liquids stream options, each criterion was given a rating from 1 to 5 (with 5 being the best) and a weighting of 1 to 5 (with 5 being the most important).

Table 4-14 summarizes the evaluation of the five options.

**Table 4-14 Rating Table of Options**

	Weighting (1 to 5)	Option S1 Dig.	Option S2 Dig. Cake	Option S3 Lime	Option S4 Compost	Option S5 Solar Dry
<b>Technical</b>						
Proven Reliability	5	5	5	1	1	3
Robustness	4	4	5	1	1	5
Flexibility	4	1	2	4	3	5
Space Requirements	5	5	4	3	2	1
Expandability	3	1	1	5	4	3
Constructability	3	3	3	5	2	2
<b>Operational</b>						
Ease of Operation	4	4	5	1	3	3
Ease of Maintenance	4	4	3	1	3	3
Operator Safety	4	4	4	1	3	3
Operator Environment	2	5	4	1	3	2
<b>Environmental &amp; Aesthetic</b>						
Visual impact	3	3	3	2	1	3
Noise	4	1	2	3	3	3
Odour/ Dust	0	5	4	1	2	3
<b>Subtotal</b>		<b>153</b>	<b>158</b>	<b>102</b>	<b>106</b>	<b>136</b>

**Table 4-14 Rating Table of Options (continued)**

	Weighting (1 to 5)	Option S1 Dig.	Option S2 Dig. Cake	Option S3 Lime	Option S4 Compost	Option S5 Solar Dry
<b>Economic Criteria</b>						
Relative Construction Cost	5	4	3	5	3	4
Relative O&M Cost	5	3	4	1	2	5
<b>Subtotal</b>						
<b>Subtotal</b>		<b>35</b>	<b>35</b>	<b>30</b>	<b>25</b>	<b>45</b>
<b>Overall Weighted Score as a Percentage of the Maximum Possible</b>		<b>68%</b>	<b>70%</b>	<b>46%</b>	<b>47%</b>	<b>62%</b>

This rating of the options takes into account issues specific to the San Fernando site, and solids reuse and disposal issues specific to Trinidad. The results indicate that aerobic digestion and cake dewatering (Option S2) is the most appropriate for San Fernando. The second highest rated option, S1 (Hauling Liquid Sludge from the digesters) could also be incorporated into the treatment plant simply by providing a tanker truck filling station. A further advantage of Option S2 is that it does not preclude WASA from installing an off-site solar drying plant in the future, say at one of the Mega Farms.

#### 4.4 No Action Alternative

An alternative to the proposed project is ‘No Action’ in which the proposed project is not undertaken. The proposed development is part of a larger WASA Wastewater Master Plan that has identified the need for improved wastewater treatment in Trinidad and Tobago. Implications of the ‘No Action’ alternative are that the problems that have been identified in the catchment area and surrounding area will continue and are acceptable.

The problem of non-functional wastewater treatment plants (WWTPs) servicing private housing developments has been a persistent wastewater and surface water management issue in Trinidad for several decades. The identification of these small private WWTPs and the inefficient treatment of sewage resulting in the pollution of watercourses, have been assessed over the last decade with many of the privately owned WWTPs identified as non-functional (Rodriguez-Atwell 2000).

Without the proposed project, urbanization and population growth will result in increasing volumes of untreated domestic and small quantities of industrial wastewater being discharged into the rivers and drains and a consequent deterioration in surface water quality. The pollution of surface water would continue to affect and threaten drinking water safety and thus the health of urban and rural residents. The area’s ecosystem, and particularly aquatic life, will be significantly degraded. The downstream water quality in the Guaracara, Marabella, Vistabella and Cipro Rivers will be negatively affected. The quality of life and the standard of living of residents of the project area will deteriorate.



Implementation of the proposed project will significantly reduce the direct discharge of untreated wastewater, thereby contributing to the long-term goal of cleaning up the rivers within the catchment area and improving related ecological, physical, and health conditions.



## 5. Biophysical Environment Setting

### 5.1 Introduction

Trinidad is located 11° N and 61° W on the southern end of the Caribbean archipelago. The island is approximately 5,000 km<sup>2</sup> and is surrounded by the Gulf of Paria on the west, Caribbean Sea in the north, Columbus Channel to the south and Atlantic Ocean in the east.

The San Fernando Wastewater Project area is located in south-western Trinidad. The physical area of the catchment is bordered by Guaracara River to the north, M2 Ring Road to the south, Solomon Hochoy Highway to the east, inclusive of Ste. Madeline, and the Gulf of Paria on the west (Figure 3-1).

The TOR set by the EMA declared that a detailed survey of the biophysical environment was required in order to meet the CEC guidelines. This is necessary to determine the baseline conditions within the natural environment so the impact of the project could be determined based on an evaluation of the existing situation and the cumulative impacts of simultaneous projects within the study area.

The baseline conditions that were identified included all aspects of the ecological environment such as:

- Climate
- Natural Hazards
- Geology
- Soils
- Topography
- Hydrology
- Water Quality
- Flora
- Fauna
- Ambient Noise
- Ambient Air

Surveys were conducted throughout the project schedule and secondary research was carried out to supplement the data collected. Each characteristic of the biophysical environment will be discussed in this Section.

### 5.2 Climate

Trinidad has two clearly defined seasons; a dry and wet season on an annual basis. The dry season extends from January to May and is distinguished by little rainfall or drought spells and higher temperatures. The wet season starts in June and ends in December and opposite climatic conditions occur including heavy rainfall and lower temperatures.

The climate of Trinidad does not vary much spatially. Climate would be discussed in the context of wind speed and direction, temperature, humidity and precipitation. These parameters are measured by the Meteorological Services of Trinidad and Tobago under the Ministry of Public Utilities. The





stations managed by this division are located in north-eastern Trinidad at the Piarco International Airport and the information was obtained for the Piarco area from an internet weather service called Weather Underground Incorporated. The monthly average of each parameter was used for this baseline assessment.

### 5.2.1 Wind Speed and Wind Direction

Mean monthly wind speed values for the period January 2005 to April 2010 provide an average indication of the wind speed experience in Trinidad and therefore within the project area. Figure 5-1 presents these values in graph and tabular form. As depicted the highest wind speeds are typically experienced from January to July of each year with the speed decreasing in the last 5 months of the year. Between the periods 2005 to 2010, the year 2010 had the highest recorded wind speeds to date. The highest winds were felt in February and lowest in August. The generally observed trend is that the mean wind speed fluctuates on a monthly basis between 2 km/hr and 8 km/hr.

The wind direction in Trinidad is predominantly north easterly since the island is affected by the North East Trade Winds. The trade winds are created when the winds flow from the subtropical high points to the low pressure zone called the Inter Tropical Convergence Zone (ITCZ). In the Northern Hemisphere these trade winds blow in a north-easterly direction. Northeast Trade Winds are dominant between November and July. When the ITCZ shifts northward the South East Trade Winds dominate from August to October.

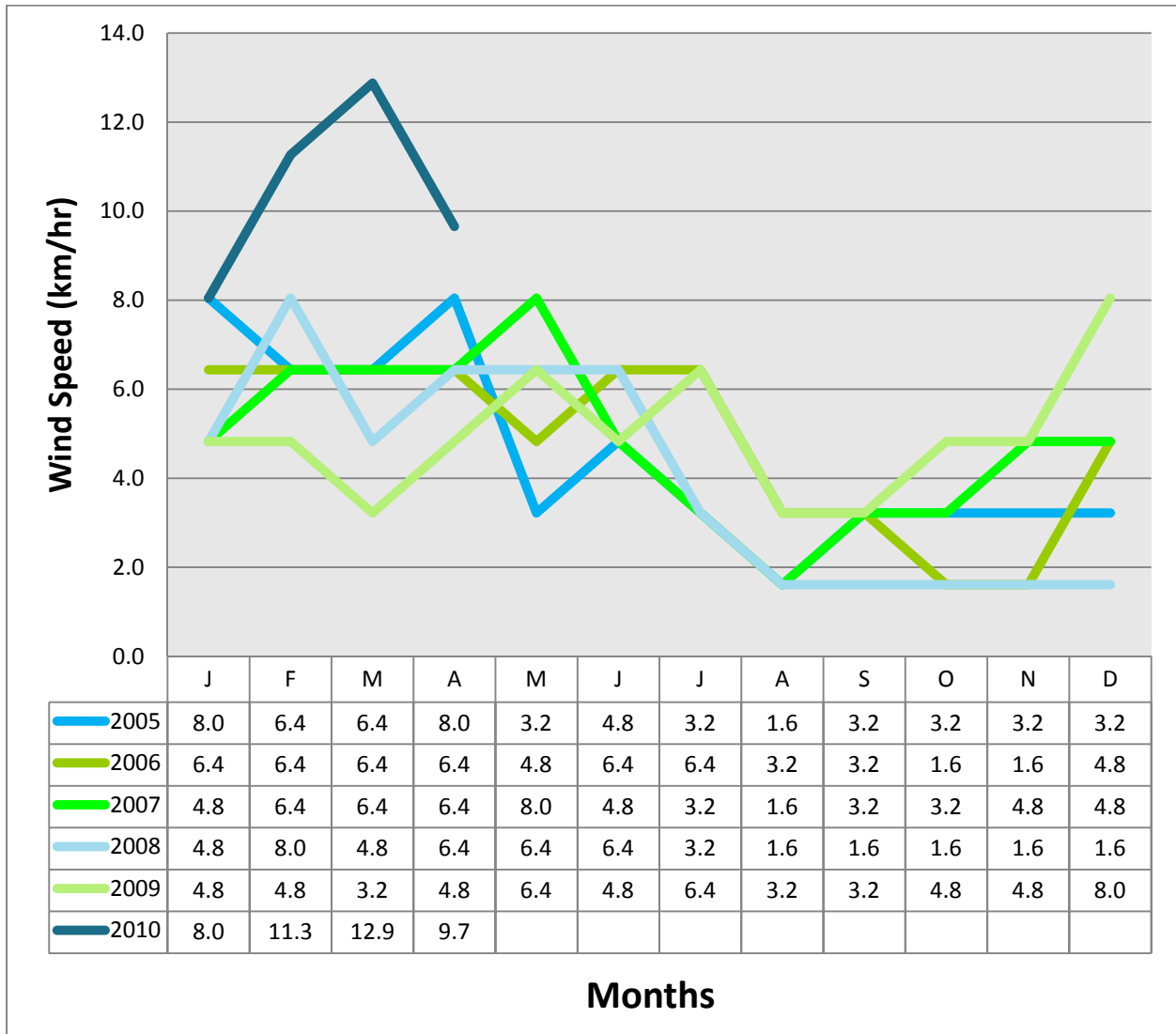


Figure 5-1 Mean Monthly Wind Speeds (Weather Underground Inc.)

### 5.2.2 Temperature

The temperature data for Trinidad recorded at Piarco International Airport was also obtained from Weather Underground Incorporated. The mean monthly temperatures for the period January 2005 to April 2010 are illustrated in Figure 5-2. Similar to the wind speed experienced in Trinidad the temperature records are highest for the period January 2010 to April 2010 inferring that 2010 has seen a drastic change in climate on the island. Generally, lower temperatures are recorded from November to February with January having the lowest temperatures for each of the 6 years. Higher temperatures are felt from March to October peaking in May and September.

Typically, during the month of September and primarily October there is a sudden flux in temperature values that is a result of the climate phenomena called ‘Petit Careme’. This is also known as the second



dry season where similar conditions are experienced in these months as in the established dry season. Proceeding, 'Petit Careme' the temperature declines until January of the following year.



Figure 5-2 Mean Monthly Temperatures (Weather Underground Inc.)

### 5.2.3 Humidity

The humidity levels in Trinidad are fairly high due to its tropical location. In some months, the maximum humidity level is 100% however the average monthly humidity ranges from 70% to 85%. The lowest humidity levels have been recorded from March to May with lowest values in April. The humidity gradually increases from May to July until it remains fairly constant from July to January, peaking in October. Humidity levels slightly increase during September and October as a result of 'Petit Careme' contributing to the dry season conditions felt during this period.

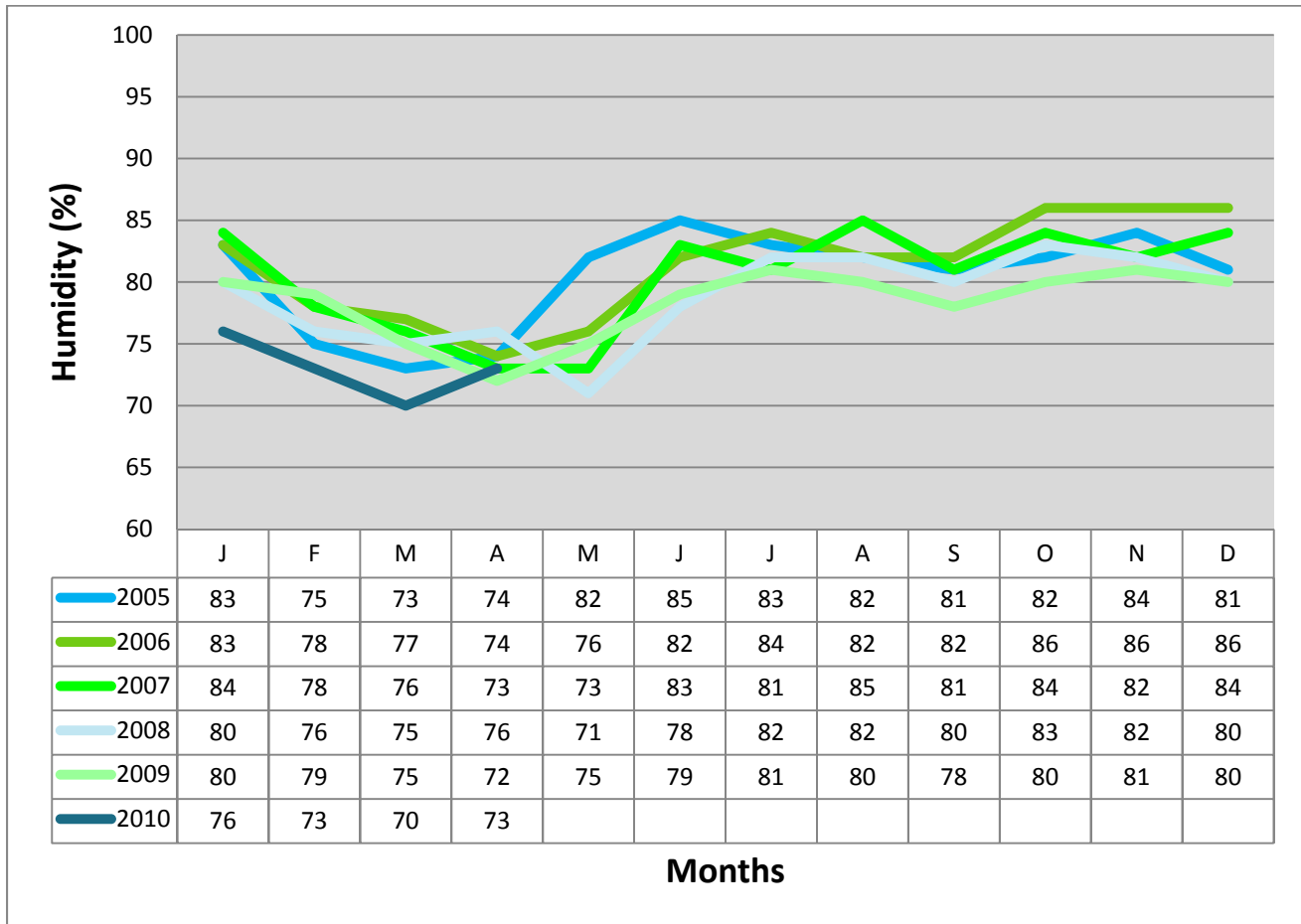


Figure 5-3 Mean Monthly Humidity (Weather Underground Inc.)

### 5.2.4 Precipitation

Precipitation levels are dictated by the wet and dry seasons experienced in Trinidad. During the dry season, commencing in January, rainfall levels are low and continue to decrease until April and sometimes May with the lowest precipitation typically being experienced in February (Figure 5-4). The month of May usually indicates the start of the wet season and rainfall levels increase until August.

In the ‘Petit Careme’ season which occurs from September to October, precipitation decreases but is followed by heavy rainfall events for the rest of the wet season. November typically has the highest rainfall levels based on this historic data. The spatial difference in rainfall is depicted in Figure 5-5. As illustrated, the San Fernando Project area is expected to have a 75 year mean annual rainfall of 1600 mm.

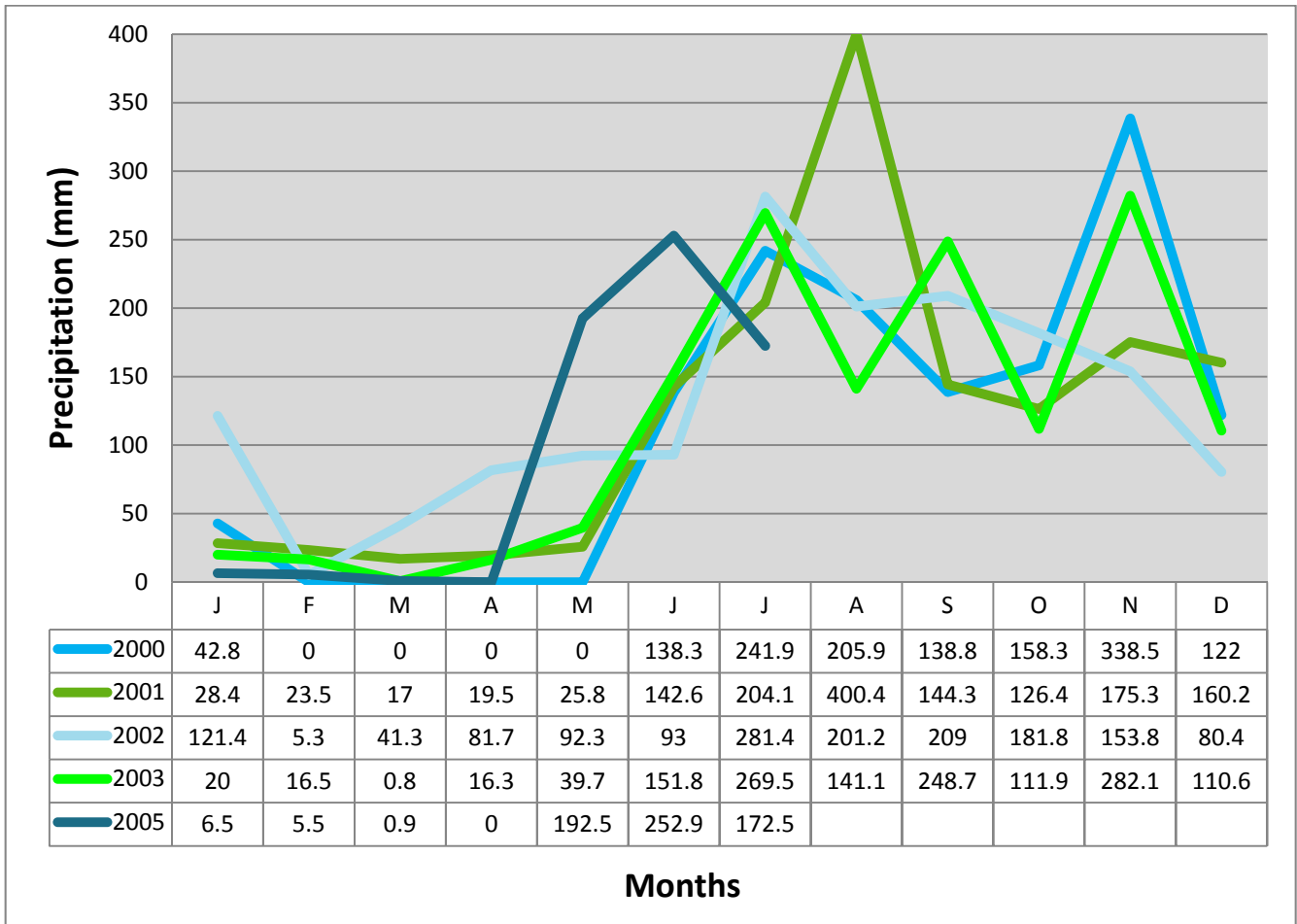


Figure 5-4 Mean Monthly Precipitation (Meteorological Services Division)

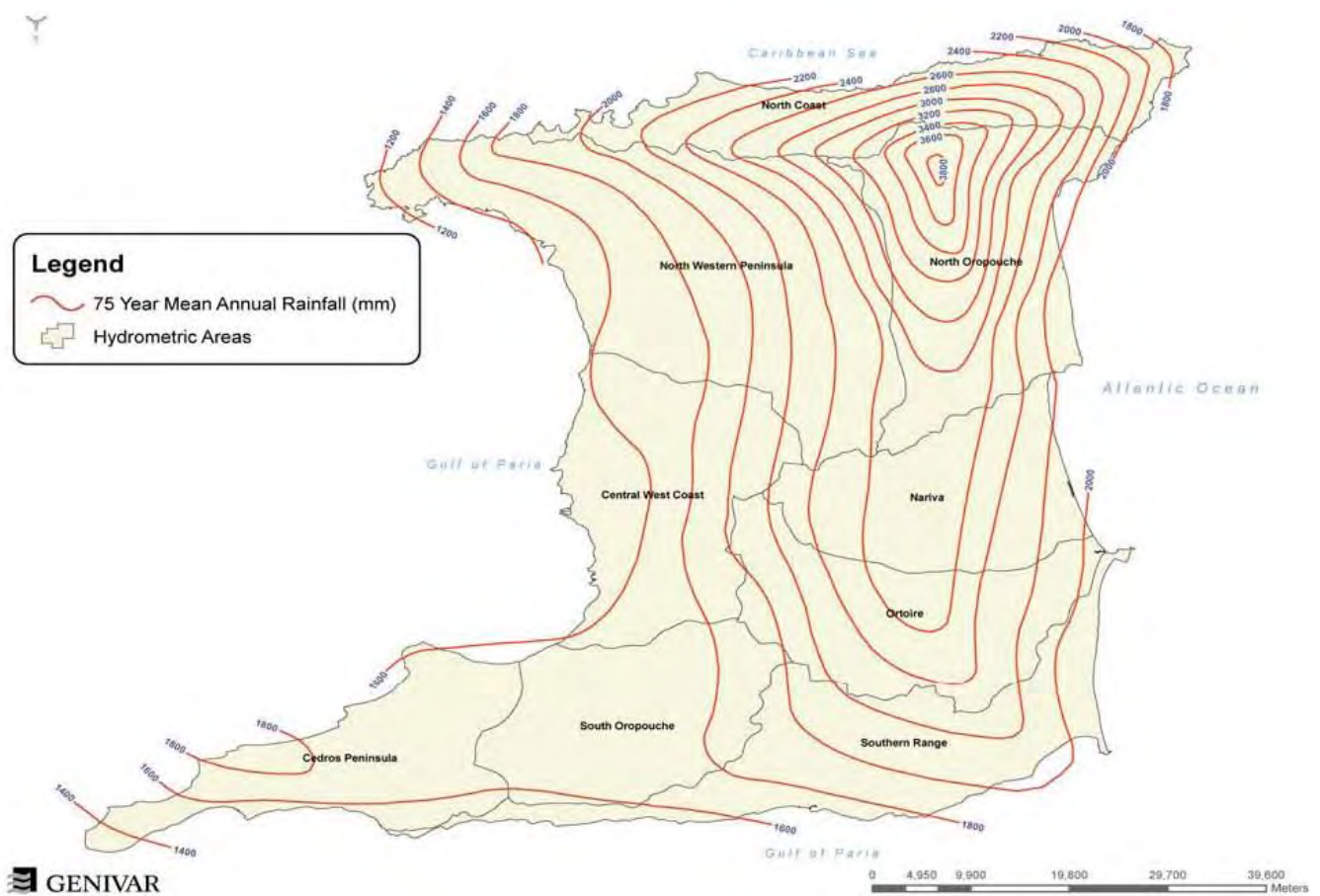


Figure 5-5 Isohyetal Map of Trinidad (Genivar, 2009)

### 5.3 Natural Hazards

Trinidad like any other country is prone to many natural hazards. Whether these hazards result in a disaster depends on the community in which it occurs and therefore the effect the event has on the population. Natural hazards are uncommon but not impossible in the San Fernando Wastewater Catchment area. The different types of events that can potentially occur are discussed in the context of Trinidad drawing specific reference to communities within the project area where these disasters have occurred, or where due to existing conditions, these communities are likely to have a high incident possibility.

#### 5.3.1 Floods

Flooding is a natural hazard that frequently occurs in Trinidad during the wet season, mainly between July and August. Flooding occurs after heavy rainfall events when rivers overflow on to their banks into surrounding agricultural lands, residential areas, business communities and roads. The San Fernando Wastewater Catchment is not largely affected by flooding due to its topography as explained in Section 5.6. The main waterways; Ciperó, Guaracara and Marabella Rivers rarely overflow because



of different hydrological factors that influence the possibility of flooding; mainly the aerial extent of the drainage catchment in comparison to the size of the river. Flood events therefore mainly affect Northern and Central Trinidad as well as communities south and east of the project area. The effects of flooding are usually;

- Loss and damage to property.
- Obstruction to traffic and roadways.
- Loss of vegetation and agricultural produce.

### 5.3.2 Bush Fires

Bush fires may or may not be considered a natural hazard because in some cases the fires are ignited manually. However, this occurrence still affects many residents of Trinidad and Tobago specifically in the dry season when the trees and grass are most susceptible to igniting. The San Fernando Wastewater Catchment area is predominantly developed land therefore bush fires are not as common. The less developed subcatchments such as Ste. Madeline, Palmiste South and Retrench/Golconda were most affected by the bush fires that occurred in the dry season of 2010. The effects of bush fires have to be considered as well for this project and they mainly include:

- Loss of vegetation and agricultural crops.
- Loss of wildlife and habitat.
- Loss and damage to property.

### 5.3.3 Hurricanes

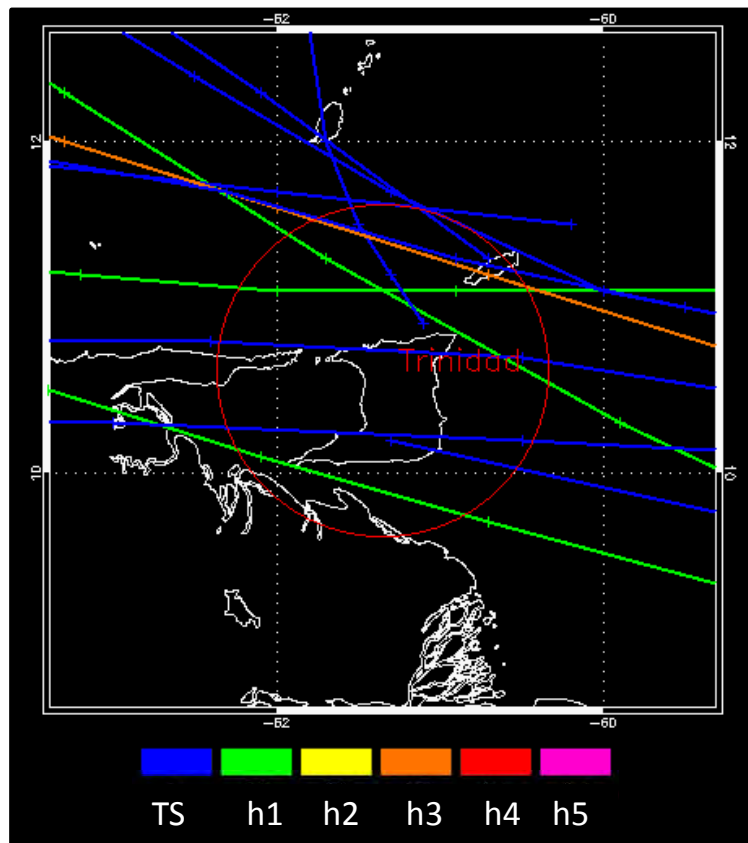
Hurricanes are common to the Caribbean region because it is in the direct path of the Atlantic Hurricane Track. The hurricanes form on the west coast of Africa and eventually move over the Atlantic Ocean increasing in intensity as they approach the Caribbean. Fortunately, Trinidad is located slightly southwest of the track and, as a result, is not in the direct path of these hurricanes. The hurricane season in Trinidad ranges generally from June to November. Figure 5-6 portrays the hurricane routes from 1851 to 2008. As illustrated only tropical storms have directly passed over Trinidad while category 1 hurricanes have mainly passed off the coast in the marine waters. Table 5-1 lists the names and wind speeds of these hurricanes and tropical storms.

A tropical storm is usually categorised by wind speeds of 63 to 118 km/hr and category 1 hurricanes have wind speeds between 119 and 153 km/hr. The last tropical storm that passed over Trinidad was Joyce in October 2000. Despite the historic tracks, hurricanes that pass close to the island still cause heavy rainfall, flooding, rough waters and high winds.



**Table 5-1 List of Hurricanes and Tropical Storms Affecting Trinidad**

Name of Hurricane/Tropical Storm	Date	Category	Wind Speeds (km/hr)
No Name	September 1878	1	148
No Name	October 1892	1	130
No Name	November 1896	Tropical Storm	74
No Name	August 1928	Tropical Storm	64
No Name	June 1933	1	130
Anna	July 1961	Tropical Storm	84
Flora	October 1963	3	204
Alma	August 1974	Tropical Storm	74
Arthur	July 1990	Tropical Storm	84
Fran	August 1990	Tropical Storm	64
Bret	August 1993	Tropical Storm	93
Joyce	October 2000	Tropical Storm	64

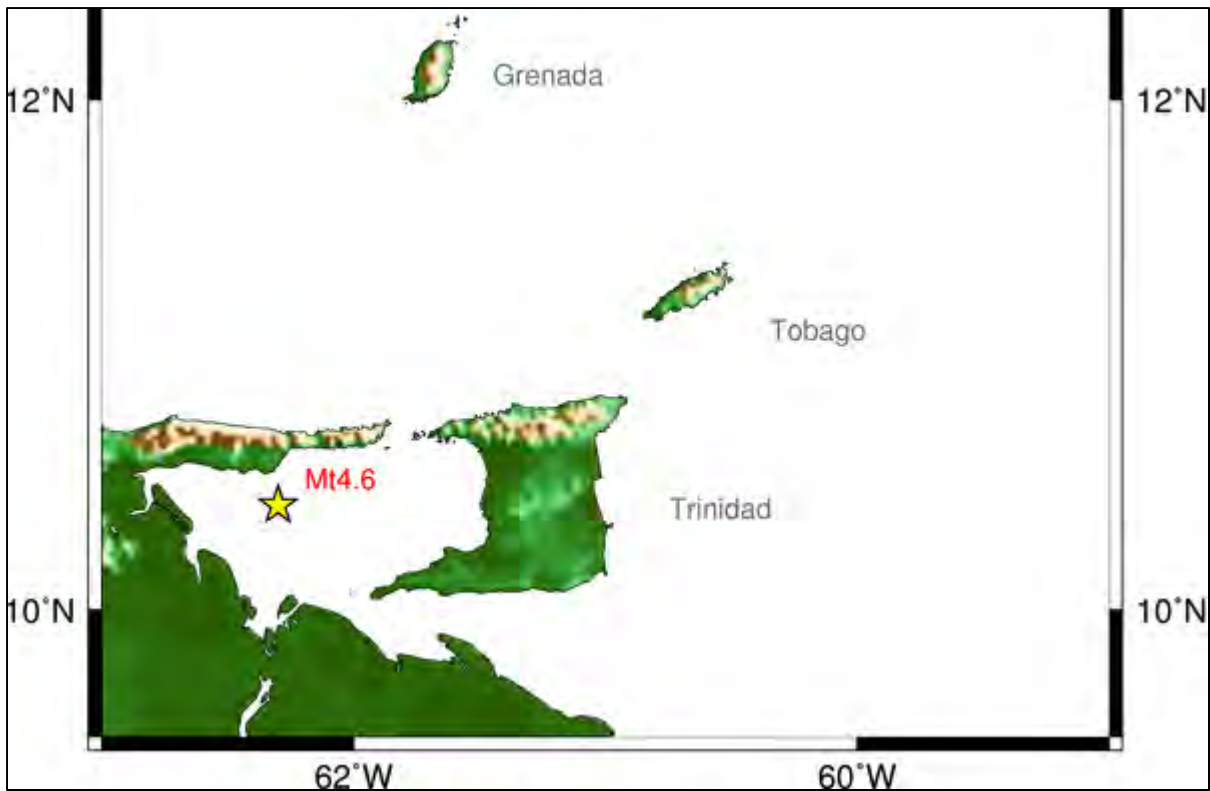


**Figure 5-6 Hurricane Tracks for Trinidad during the period 1851 to 2008 (Storm CARIB Caribbean Hurricane Network)**



### 5.3.4 Earthquakes

Trinidad and Tobago is located at the boundary of the Caribbean and South American Plates therefore placing the islands in an earthquake prone zone. Major earthquakes have been prevalent in recent times within the Lesser Antilles. Most of the earthquakes that occur close to Trinidad are low magnitudes, the last one having occurred on April 21, 2010 in the Gulf of Paria; magnitude 4.6 and depth 4 km (The University of the West Indies Seismic Research Centre). Figure 5-7 depicts the location of the epicentre of this earthquake and despite the distance from Trinidad the activity was still felt in parts of Northern Trinidad.



**Figure 5-7 Recent Seismic Activity in Trinidad on 21 April 2010**

The last two major earthquakes to hit Trinidad occurred on the same day of November 22 2009 with a magnitude of 5.0 and 5.1. Shocks were felt in both northern and southern Trinidad with no major damage recorded. Seismic activity records from 1900 to 2005, indicate the epicentres of these earthquakes mainly in the coastal regions with magnitudes lower than those within the Lesser Antilles (Figure 5-8).

Earthquake prediction has become very popular since the earthquake that occurred in Haiti in February 2010. The Seismic Research Unit at the University of the West Indies has undertaken continuous investigations of plate tectonics and seismicity in the Caribbean. The Unit has formulated a predictive hazard map for earthquakes for the entire region. The hazard map for Trinidad is illustrated in Figure 5-9 and portrays the potential acceleration of particles if an earthquake were to occur.

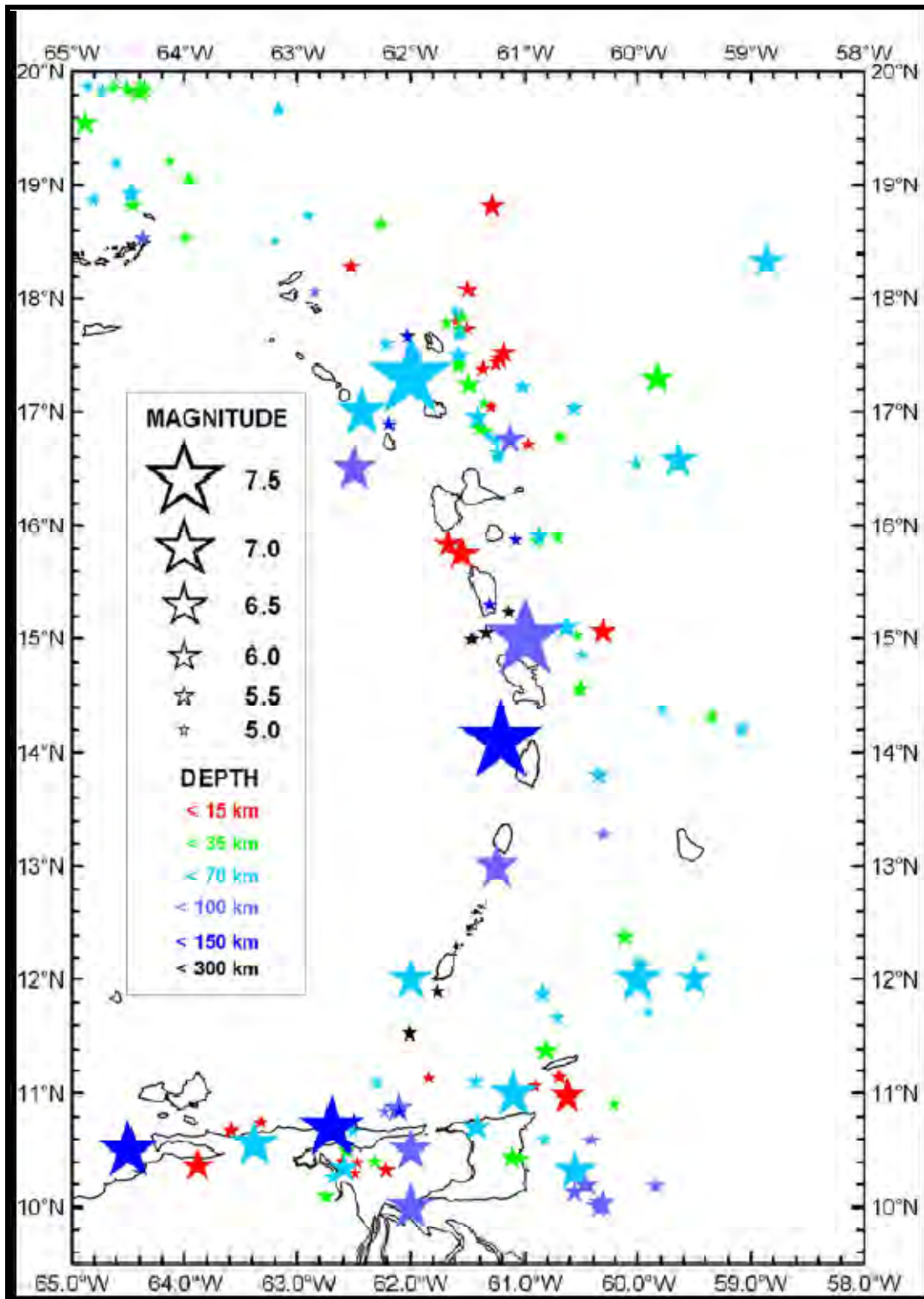
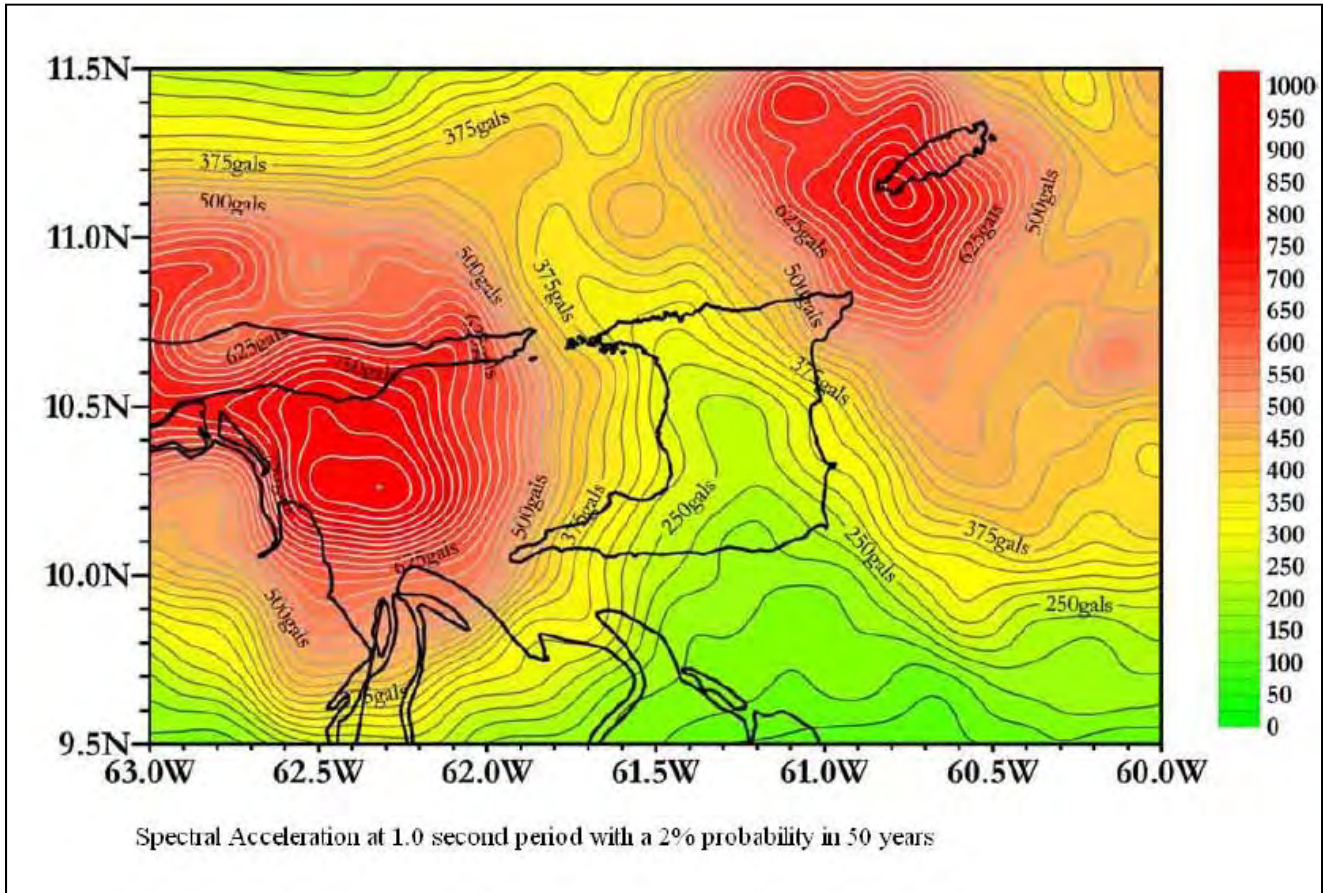


Figure 5-8 Earthquake Epicenters with Magnitudes Greater Than 5 from 1900 to 2005



**Figure 5-9 Seismic Hazard Map of Trinidad**

The possible effects of earthquake activity include:

- Collapsed structures
- Damaged infrastructure
- Slope movement
- Tsunamis
- Liquefaction

### 5.3.5 Tsunami Hazards

Tsunamis in the Caribbean region have not created as much destruction to life and property as the other natural hazards. According to the Seismic Research Unit, a tsunami can form within the Caribbean in three instances, through;

- Local earthquakes occurring at a depth of less than 50 km with a minimal magnitude of 6.5.
- Distant earthquakes occurring outside of the Caribbean but producing ‘tele-tsunamis’.
- Submarine volcanic eruption displacing water to generate a tsunami.



Even though Trinidad has not been affected by a major tsunami event, the possibility exists. A Tsunami and Coastal Hazard Warning System was implemented in March 2010 by the Office of Disaster Preparedness and Management (ODPM), however the Pacific Warning System will also be able to identify a potential tsunami wave.

## 5.4 Soils

Soil investigations were undertaken at the San Fernando WWTP and within the collection system. Geotech Associates Limited was sub-contracted to conduct the geotechnical investigations for this project. Work at the WWTP was completed in December 2009 and for the Collection System in April 2010, both geotechnical reports are attached in **Appendix D.1**.

### 5.4.1 San Fernando WWTP

The soil at the WWTP was classified according to the Soils Map of Trinidad and Tobago produced by the Lands and Survey Division of the Ministry of Planning, Housing and the Environment (Figure 5-10). The soil type is described as Sevilla Clay which is deep alluvial soil with restricted internal drainage. The soil profile at the SFWWTP site comprises mainly cohesive material and can be divided into 3 units based on soil type, standard penetration resistance, and moisture content.

Soil Unit 1 was found in a number of the borehole locations across the site and ranged from approximate depths of 4.6 metres to 6 metres below ground. The soil is very soft to soft and medium stiff silty clays. There are slight traces of sand and occasional traces of organic material, isolated gravel and peaty silty clays. In one borehole Soil Unit 1 consisted of layers of fill and stiff to very stiff silty clays. The natural moisture content of this unit was calculated between 27.1 to 66.2%.

Soil Unit 2 extended below Soil Unit 1 from approximately 6 metres to 9 metres subsurface. The unit is predominantly composed of medium stiff to very stiff silty clays with traces of sand and isolated gravel. The natural moisture content of Soil Unit 2 is between 20.4 to 44.7%.

Soil Unit 3 is found below Soil Unit 2 extending to average depths of 11 metres in some boreholes and 17 metres in others. The unit consists of very stiff to hard silty clays with slight to frequent remnants of sand, occasional gravel and silty sandy clays. The natural moisture content of Soil Unit 3 varies from 21 to 51%.

The grain size composition of each soil unit was analyzed in the geotechnical investigations at the San Fernando WWTP. The data is presented in Table 5-2. In addition, chemical testing of samples from 3% of the total number of borehole sites were done. This was used to give an indication of the chemical range of subsoils; the following parameters were tested and the ranges were:

- pH 6.87 – 7.94
- Sulphate (%) 0.005 – 0.027
- Chloride (%) 0.033 – 0.274

The groundwater conditions at the borehole sites were also measured by Geotech Associates Limited. Generally, in areas where the elevation of the ground surface was between 3 and -1 metres above sea level (masl) the groundwater level ranged from 0.6 to 4 metres below ground. At sites where the



elevation was between 1.9 and -1.4 masl the observed groundwater level ranged from 1 to 3 metres below the ground surface.

**Table 5-2 Grain Composition of Soil Units**

Grain Size	Soil Unit 1 (%)	Soil Unit 2 (%)	Soil Unit 3 (%)
Gravel	0 – 7.8	0 – 12.8	0 – 14
Sand	1.1 – 23.3	0.6 – 13.8	0.6 – 39.2
Silt	20.7 – 37.1	20.6 – 31.5	15.3 – 29.2
Clay	46.6 – 77.2	51.6 – 78.4	37.5 – 81.5

#### 5.4.2 San Fernando Collection System

The soil investigations within the entire project area were undertaken to identify the geotechnical conditions of the collection system for both environmental and design purposes. The soil types, according to the Soils Map of Trinidad, 1971, fall into two different groups;

- Group B - Soils of the Alluvial Plains and Valleys
- Group C - Soils of the Uplands

There are four different soil classes in these two groups, found within the San Fernando Wastewater Catchment. The most dominant are the Princes Town Clay that fall under Group C, the lithological composition of this soil type is marl with imperfect drainage. Talparo Clays, which are part of Group C, are also encountered in parts of the project area; drainage is typically impeded in this soil and the lithology is mainly clay shale. Another soil class in the San Fernando Area under Group C is the Tarouba Clays which has impeded drainage and the lithological composition is primarily calcareous clay shales. These Group C soil types are generally intermediate upland soils with restricted internal drainage.

The only soil class in the project area belonging to Group B is the Sevilla Clays; this class is found predominantly along the course of the Ciperio River. These are imperfectly drained, deep alluvial soils with restricted internal drainage and have a clay alluvium lithological component.

Sixty boreholes were drilled throughout the catchment, shown in Figure 5-11. Table 5-3 lists the location and area in which these boreholes were sited. The results of the investigation are affixed in **Appendix E.1**.

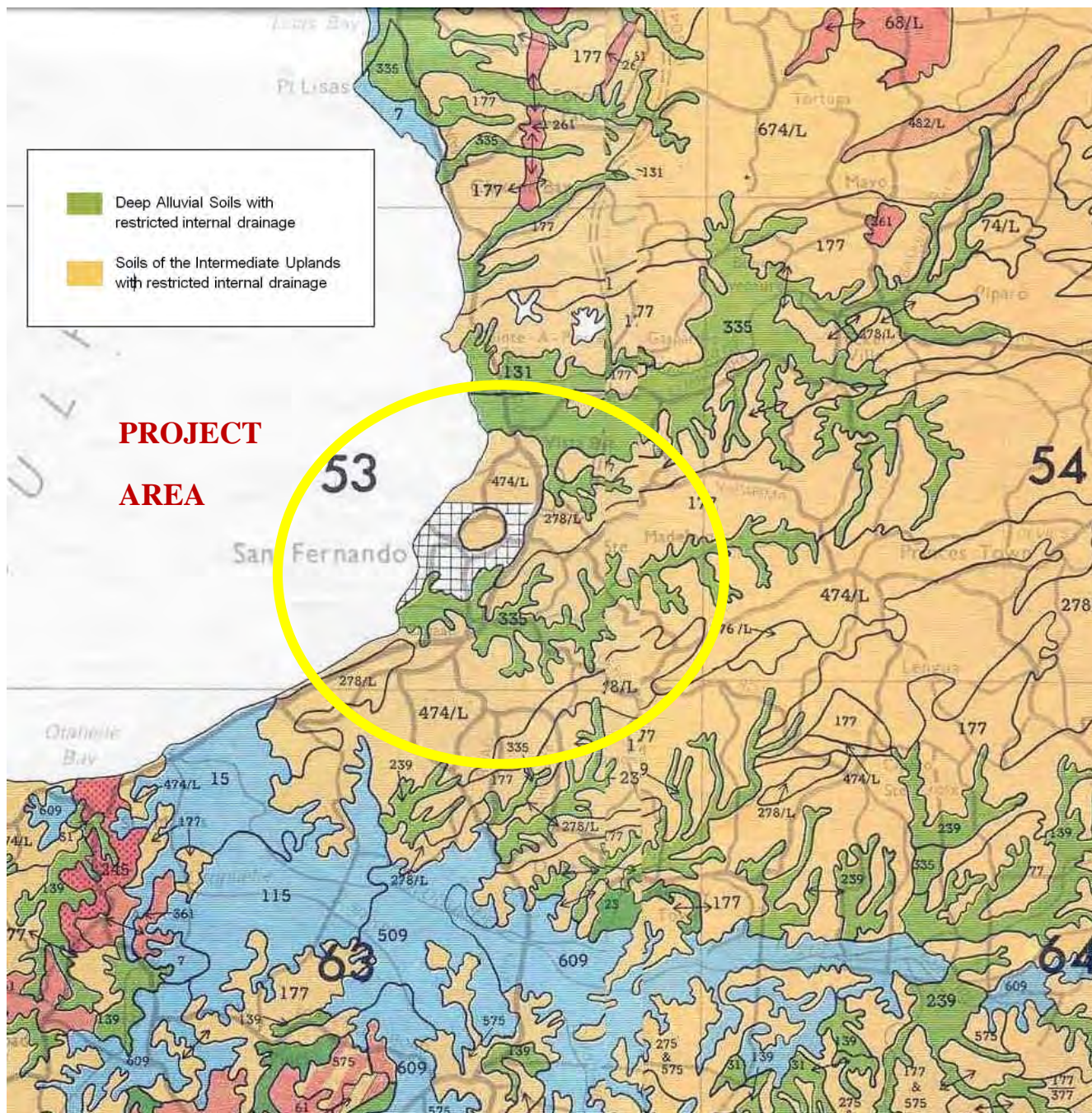


Figure 5-10 Soils Map of Trinidad, 1971 (Lands and Surveys Division)



Figure 5-11 Sites of Soil Investigation within San Fernando Collection System



**Table 5-3 List of Borehole Sites for San Fernando Wastewater Collection System**

Area	Depth	Northing	Easting
WWTP	11.1	1135252	667357
	9.6	1135075	667385
Marabella	5.6	1139058	669717
	5.4	1139041	669584
	5.0	1139098	669486
	4.3	1139169	669279
	5.0	1139169	668997
	6.4	1139210	668897
	3.7	1139155	669078
	6.7	1138958	668925
	9.3	1138628	668860
	11.3	1138409	668768
	8.9	1138196	668623
	Tarouba-Cocoyea	3.6	1137869
6.7		1137577	669975
Pleasantville-Corinth	3.3	1134722	669048
	2.7	1134764	669027
	2.1	1134581	669105
	2.4	1134585	669336
	2.3	1134694	669560
	1.7	1134695	669796
	4.7	1134695	669971
	5.3	1134716	670121
	4.9	1134656	670323
	4.5	1134675	670494
	4.0	1134670	670720
	Green Acres	5.0	1135011
5.0		1134914	668371
San Fernando Central	10.6	1137626	668003
	7.9	1137442	667869
	8.3	1137333	667715
	8.9	1137070	667579
	9.8	1136763	667453
	10.7	1136639	667348
	11.6	1136542	667256
	12.5	1136430	667211
	11.6	1136185	667277
	13.4	1135974	667348
	15.1	1135818	667399



**Table 5-3 List of Borehole Sites for San Fernando Wastewater Collection System (continued)**

Area	Depth	Northing	Easting
San Fernando Central	15.1	1135602	667473
	13.9	1135481	667472
	12.4	1135423	667439
	11.0	1135317	667412
San Fernando South	6.6	1135071	667570
	8.1	1135072	667752
	5.0	1135038	667946
	5.0	1134985	668130
	5.0	1134984	668270
	3.5	1134841	668520
	5.0	1134651	668644
	6.6	1134661	668874
Vistabella	3.787	1138099	669806
	3.395	1138182	669372
	4.227	1137977	669003
	6.277	1137997	668831
	5.973	1138029	668654
	9.533	1137907	668437
	10.312	1137763	668243
	10.312	1137704	668107

Note:\*\*Coordinate datum – Naparima 1955; UTM Zone 20N

## 5.5 Geology

Trinidad is located on the southern end of the Caribbean Plate and is arguably between the Caribbean and South American Plates. The geology of Trinidad is complex and there are many theories behind the intricate details of the faults, formations and their deposition.

Trinidad is divided into five different physiographic regions as depicted in Figure 5-12. The San Fernando Wastewater Catchment is located within the Southern Basin which is a synclinal structure. The geographical expression of this structure is a series of undulating hills and basins.

The geological formations (FM) that comprise the project area are depicted in Figure 5-13 and listed in Table 5-4 in decreasing chronological order. The age of the FMs are based on the stratigraphic chart of Trinidad. J.B. Saunders in 1997 updated the previous geological map of Trinidad which was produced by H.G. Kugler in 1959.

The Naparima Hill Formation according to Saunders, 1997 is what is known as the San Fernando Hill. This FM was deposited in a deep water, low energy environment and is the oldest within the project area but was uplifted due to tectonic activity.

One of the more dominant geological formations in the San Fernando Wastewater Catchment is the Cipero FM. This FM was deposited in a deep water environment after the sedimentation of the San Fernando Formation in the Eocene. An increase in sea level is hypothesized to have caused this shift in depositional environment. The sands of the Upper Cipero Formation are important oil producers.

Another FM covering a large aerial extent is the Nariva Formation. The FM is inferred to have been deposited in a deep water marine environment since the fine-grained sediments are indicative of this setting. The sands of the Nariva FM are one of the oldest oil producers in Trinidad with several petroleum traps both onshore and offshore.

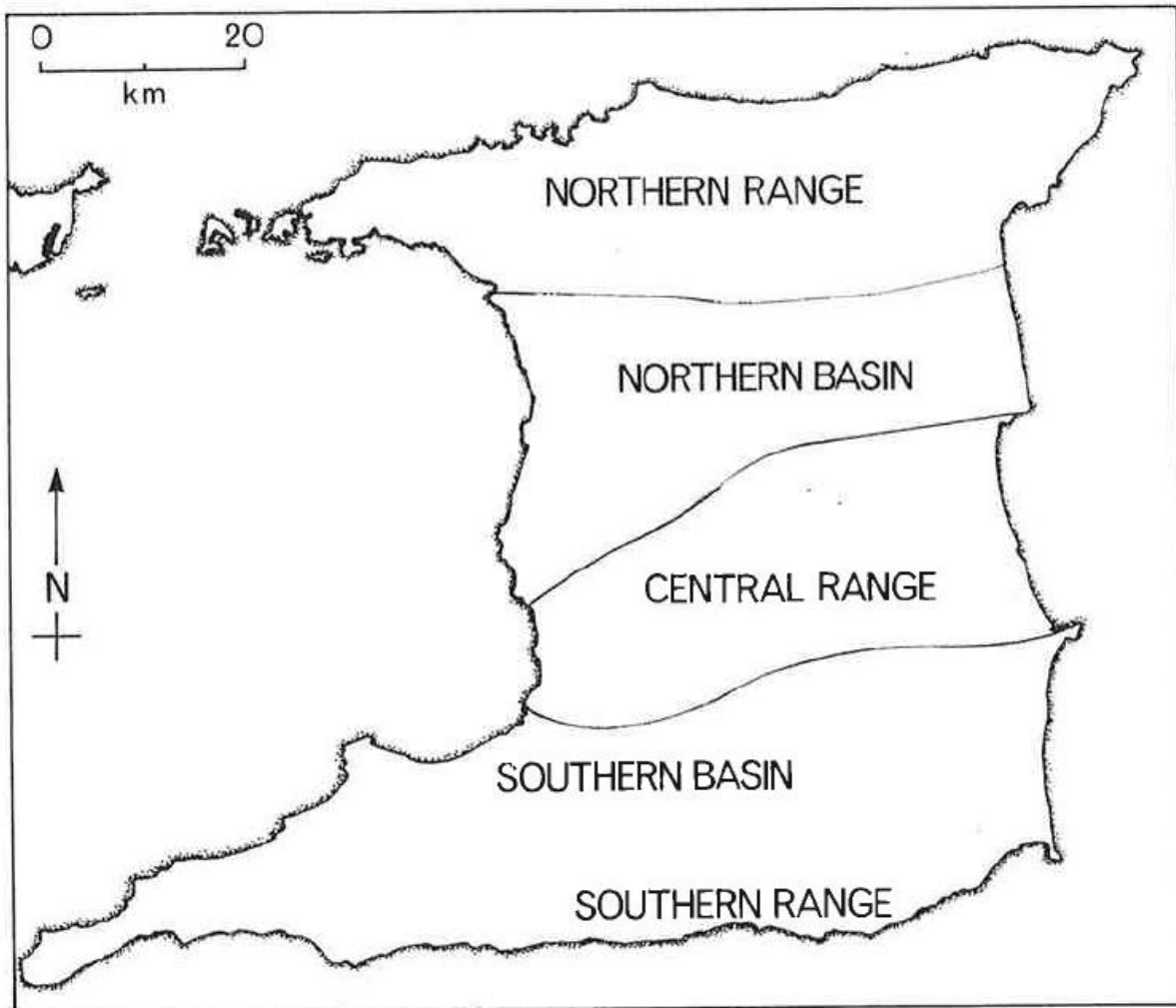


Figure 5-12 Physiographic Regions of Trinidad (Donovan, 1994)

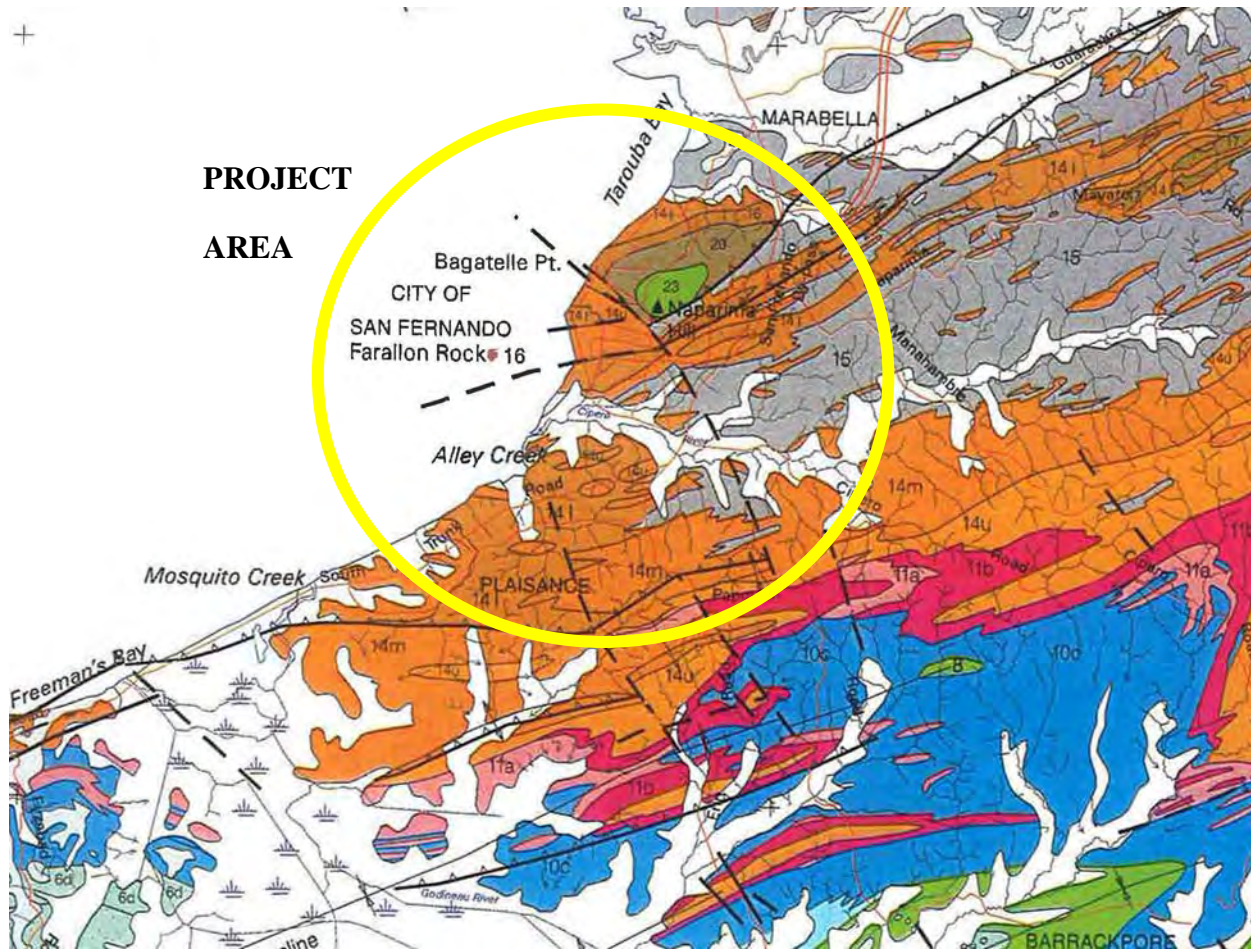


Figure 5-13 Geological Map of Project Area (Saunders, 1997)

Table 5-4 Geological Formation and Sedimentology

Geological Formation	Sedimentology	Age
Naparima Hill FM	Bituminous mudstones and shales, marls, silicified siltstones and mudstones, cherts	Cretaceous
Lizard Springs FM	Stratified marl and calcareous clay	Palaeocene
San Fernando FM	Impure sandstones, silts, glauconitic shales and calcareous foraminiferal clays	Eocene
Cipro FM	Deep water calcareous clays and marls	Miocene
Nariva FM	Mudstones and shales, silts and sands	Miocene
Cedros FM	Blocky clays, fine to coarse-grained sands	Pleistocene



There are many structural features in the Southern Basin which fashioned the nature of the geography of the region. These include the Naparima Fold Belt and the South Trinidad Fault Zone. The structural expression of these faults and folds are clay diaper anticlines, countless petroleum traps and mud volcanism in southern Trinidad. Saunders in his field investigation found two thrust faults within the San Fernando Wastewater Catchment area. One of the faults traverses perpendicular to the San Fernando Bye Pass along the vicinity of Cocoyea into Corinth. Another reverse fault was deduced parallel to the Old Southern Main Road extending perpendicular to Dumfries Road. The topography of the project area is a signature feature of these faults and many others that have not yet been identified.

## 5.6 Topography

The San Fernando Project Area is a series of undulating plains with a series of streams and rivers spread over the landscape. The San Fernando Hill is the highest point within the project area and is approximately 191 masl. The major watercourses in the project area are the Guaracara River, Marabella River, Vistabella River and Cipero River. To some extent these rivers have cut into the plains forming the existing basins and valleys.

The major roadways are aligned to the ridges of the hills in the San Fernando area. Examples of this include; the San Fernando Bye Pass and the Naparima Mayaro Road. Additional major topographical features are the marshlands found at two sites within the project area; at the mouth of the Cipero and Guaracara Rivers. These features represent areas below the mean sea water level. The Oropouche Swamp is located south of the San Fernando Catchment area outside of the project area boundary.

## 5.7 Drainage

The San Fernando project area is located mostly within the Central West Coast Hydrometric Region, with the some of the southern project area within the South Oropouche Hydrometric Region. These hydrometric areas have been divided into watersheds or catchment areas. Within the Central West Coast Hydrometric Region, the Cipero and Guaracara watersheds are within the project area (Genivar, 2009). These watersheds are defined by the major rivers which include the Cipero and Guaracara Rivers. There are also minor rivers within these watersheds including the Marabella, Vistabella, Alley's Creek and some smaller streams, all of which drain west into the Gulf of Paria (Figure 5-14).

The Guaracara Watershed covers a wider extent in comparison to the Cipero Watershed with areas of 121.52 km<sup>2</sup> and 50.68 km<sup>2</sup> respectively (Figure 5-15). The range of the Guaracara Watershed extends over the northern portion of the project area. The Godineau River is located south of the San Fernando Wastewater Catchment area within the South Oropouche Hydrometric Region. Even though this river does not flow through the project area the drains and streams in the southern areas of the wastewater catchment drain into the Godineau River and eventually into the Gulf of Paria (Genivar, 2009).

The new San Fernando WWTP is to be constructed on the site of the existing San Fernando WWTP, north of the Cipero River. River flow and height data of the Cipero River was obtained from WASA's Water Resources Agency (Table 5-5), which was used in the design of the WWTP to avoid flooding.



Figure 5-14 Drainage Features within the San Fernando Wastewater Catchment

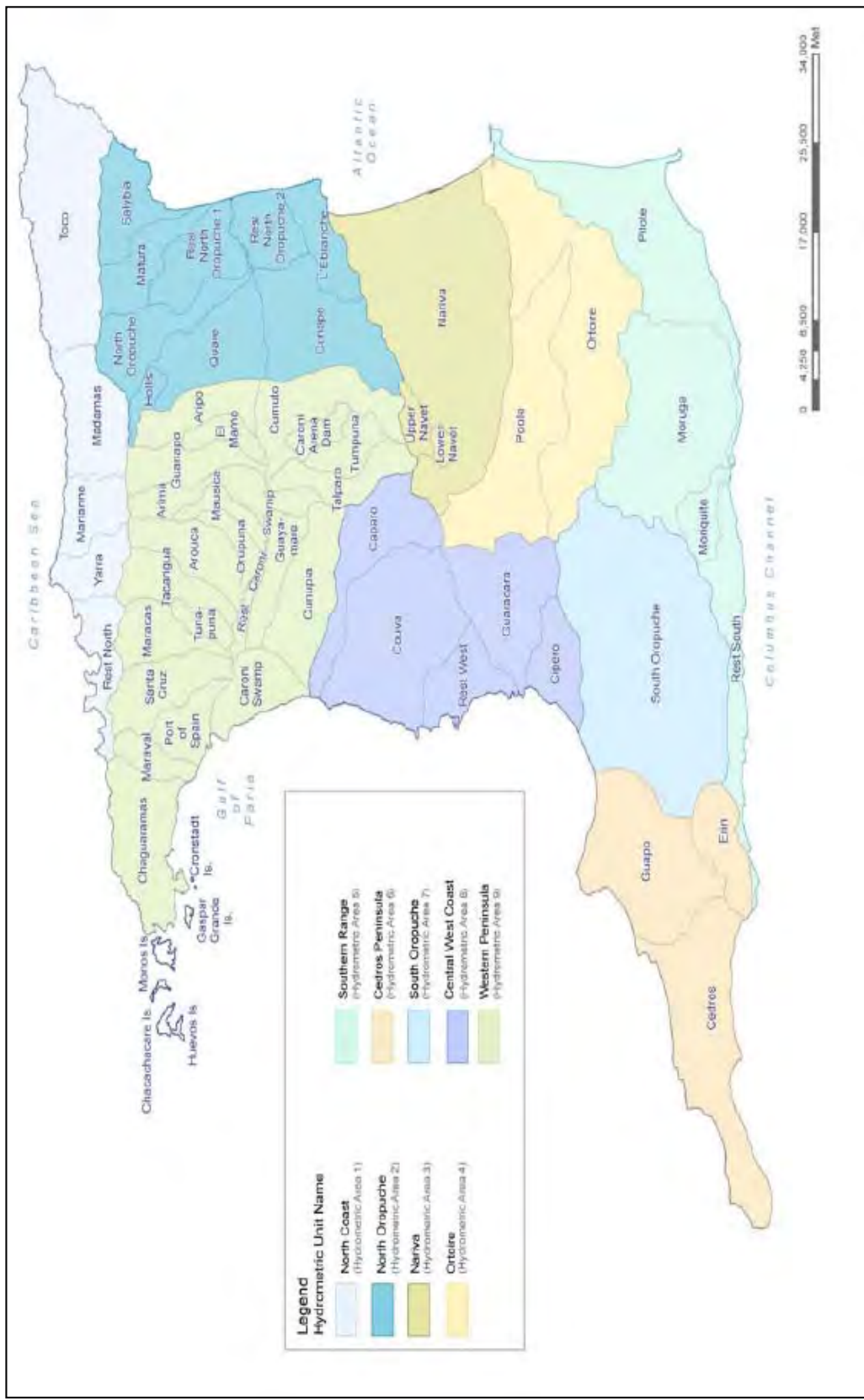


Figure 5-15 Hydrometric Areas and Watersheds of Trinidad (Genivar, 2009)

**Table 5-5 River Flow Data at Cipro River, Station Number 10803 (Water Resources Agency, 2010)**

Year	Annual Minimum Discharge (m <sup>3</sup> /sec)	Annual Maximum Discharge (m <sup>3</sup> /sec)	Instantaneous Peak Discharge (m <sup>3</sup> /sec)	Water Level Maximum (masl)	Water Level Minimum (masl)
1980	0.240	19.911	77.003	-	-
1981	0.000	25.979	-	-	-
1982	0.066	22.800	55.150	-	-
1983	0.002	12.300	48.060	-	-
1984	0.010	26.000	13.6e	-	-
1985	0.008	20.300	96.050	-	-
1986	0.025	20.400	83.240	-	-
1987	0.014	11.700	45.700	-	-
1988	0.035	23.020	88.160	5.140	0.240
1989	0.019	8.396	31.870	3.340	0.200
1990	0.030	26.421	66.590	4.570	0.080
1991	0.025	10.834	36.760	3.550	0.160
1992	0.000	28.048	44.950	5.240	0.240
1993	0.001	31.943	-	5.020	0.380
1994	0.017	8.887	19.260	2.870	0.160
1995	0.000	9.178	44.930	3.960	0.080
1996	0.000	13.582	39.157	-	-
1997	0.008	10.274	27.164	-	-
1998	0.000	18.410	79.440	4.970	-0.050
1999	0.217	12.275	13.667	3.084	0.000
2000	0.174	12.889	26.462	3.872	0.349
2001	0.126	6.647	-	3.779	0.318
2002	0.371	10.066	-	3.751	0.584
2003	0.312	4.994	-	3.369	0.530

Note: e – estimated data

## 5.8 Water Quality

Riverine water sampling was conducted on June 3<sup>rd</sup>, 2009 and October 20<sup>th</sup>, 2009. The rivers sampled included the Guaracara, Marabella, Vistabella, Cipro, and Ally's Creek as depicted in Figure 5-16. Sampling occurred upstream of the project boundary to the east, and downstream close to the Gulf of Paria. Sampling of these downstream points was conducted when the tide was going out in order for the direction of flow in the rivers to be indicative of a downstream sample. The Vistabella and Ally's Creek did not have sufficient quantities of water to allow sampling during the dry season (June 3<sup>rd</sup>,



2009). The downstream sample site for the Ciperó River was located at the eastern end of the existing San Fernando WWTP site, approximately 320 m downstream of the effluent discharge point.

Analysis of temperature, dissolved oxygen (DO) and pH were performed in-situ with calibrated equipment, while laboratory bottles were filled for the remainder of the analysis to be conducted off-site. This laboratory work was conducted by Testmark Laboratories. Calibration certificates and accreditation papers are included in **Appendix D.2**. All laboratory analyses were performed in accordance with the relevant test methods set out in the Standard Methods for the Examination of Water and Wastewater, and the results compared against the permissible limits stipulated for inland watercourses in the Water Pollution Rules, 2001 (as amended).

Results from the sampling are summarized in Table 5-6 to Table 5-10.





Figure 5-16 Sampling Locations for Water Quality Testing



**Table 5-6 Results from Analysis of Water Samples from Guaracara River**

Parameters	EMA Water Pollution Rules 2001 (as amended) 1st Schedule	Inland		Gulf	
		Dry Season	Wet Season	Dry Season	Wet Season
Temperature (°C)*	Max variation of 3°C from ambient	26.74	25.15	31.43	26.79
Dissolved Oxygen (DO) (mg/L)*	<4	3.69	5.44	0.5	3.5
Hydrogen ion (pH)*	Less than 6 or greater than 9	7.91	7.53	8.17	7.49
Five day Biological Oxygen Demand (BOD <sub>5</sub> ) (mg/L)	>10	1.3	4.4	55	3.8
Chemical Oxygen Demand (COD) (mg/L)	>60	8.8	34	380	52
Total Suspended Solids (TSS) (mg/L)	>15	12	402	1,810	38
Ammonia (as N) (mg/L)	>0.01	0.219	0.081	0.907	0.432
Nitrate (as N) (mg/L)	No limit	0.57	0.15	<10	<10
Total Phosphorus (as P) (mg/L)	>0.1	0.383	0.271	4.72	0.162
Total Chromium (Cr) (mg/L)	>0.1	<.001	0.0032	0.0037	0.0056
Dissolved Iron (Fe) (mg/L)	>1.0	0.027	0.509	4.87	0.505
Total Nickel (Ni) (mg/L)	>0.5	0.0043	0.0049	0.016	0.0054
Total Copper (Cu) (mg/L)	>0.01	0.0016	0.0089	0.154	0.038
Total Zinc (Zn) (mg/L)	>0.1	0.0367	0.046	0.0063	0.011
Total Arsenic (As) (mg/L)	>0.01	0.004	0.0015	0.0929	0.0221
Total Cadmium (Cd) (mg/L)	>0.01	<.0001	<.0001	<.0001	<.0001
Total Mercury (Hg) (mg/L)	>0.005	<.0001	<.0001	<.0001	<.0001
Total Lead (Pb) (mg/L)	>0.05	<.001	0.0022	<.001	0.0018
Total Cyanide (as CN-) (mg/L)	>0.01	<0.001	<0.001	<0.001	<0.001
Faecal Coliforms (CFU/100ml)	>100	360	8,000	315	32,000

Note: \* indicates those measurements conducted using in-situ field testing.



**Table 5-7 Results from Analysis of Water Samples from Marabella River**

Parameter	EMA Water Pollution Rules 2001 (as amended) 1st Schedule	Inland		Gulf	
		Dry Season	Wet Season	Dry Season	Wet Season
Temperature (°C)*	Max variation of 3°C from ambient	26.23	24.98	26.01	25.75
Dissolved Oxygen (DO) (mg/L)*	<4	2.98	3.76	0.68	2.07
Hydrogen ion (pH)*	Less than 6 or greater than 9	7.9	7.63	8	7.26
Five day Biological Oxygen Demand (BOD <sub>5</sub> ) (mg/L)	>10	1.3	2.2	110	3.3
Chemical Oxygen Demand (COD) (mg/L)	>60	13	42	65.1	52
Total Suspended Solids (TSS) (mg/L)	>15	15	54	1,020	27
Ammonia (as N) (mg/L)	>0.01	0.54	0.124	7.53	0.747
Nitrate (as N) (mg/L)	No limit	0.27	0.11	<1	<10
Total Phosphorus (as P) (mg/L)	>0.1	0.109	0.219	0.229	0.391
Total Chromium (Cr) (mg/L)	>0.1	<.001	0.0058	0.0043	0.0067
Dissolved Iron (Fe) (mg/L)	>1.0	0.068	0.775	6.2	0.753
Total Nickel (Ni) (mg/L)	>0.5	0.0045	0.0049	0.0104	0.0051
Total Copper (Cu) (mg/L)	>0.01	0.0267	0.0052	0.05	0.0295
Total Zinc (Zn) (mg/L)	>0.1	0.0175	0.0103	0.0211	0.015
Total Arsenic (As) (mg/L)	>0.01	0.0037	0.0025	0.0277	0.0183
Total Cadmium (Cd) (mg/L)	>0.01	<.0001	<.0001	<.0001	<.0001
Total Mercury (Hg) (mg/L)	>0.005	<.0001	<.0001	<.0001	<.0001
Total Lead (Pb) (mg/L)	>0.05	<.001	<.001	0.001	<.001
Total Cyanide (as CN-) (mg/L)	>0.01	<0.001	<0.001	<0.001	<0.001
Faecal Coliforms (CFU/100ml)	>100	8,000	11,000	49,000	46,000

Note: \* indicates those measurements conducted using in-situ field testing.



**Table 5-8 Results from Analysis of Water Samples from Vistabella River**

Parameter	EMA Water Pollution Rules 2001 (as amended) 1st Schedule	Inland	Gulf
		Wet Season	Wet Season
Temperature (°C)*	Max variation of 3°C from ambient	26.38	27.62
Dissolved Oxygen (DO) (mg/L)*	<4	3	0.22
Hydrogen ion (pH)*	Less than 6 or greater than 9	7.43	7.27
Five day Biological Oxygen Demand (BOD <sub>5</sub> ) (mg/L)	>10	5.1	7.7
Chemical Oxygen Demand (COD) (mg/L)	>60	38	79.9
Total Suspended Solids (TSS) (mg/L)	>15	21	20
Ammonia (as N) (mg/L)	>0.01	1.21	2.91
Nitrate (as N) (mg/L)	No limit	0.33	<10
Total Phosphorus (as P) (mg/L)	>0.1	0.489	0.727
Total Residual Chlorine (as Cl <sub>2</sub> ) (mg/L)	0.2		
Total Chromium (Cr) (mg/L)	>0.1	0.005	0.0078
Dissolved Iron (Fe) (mg/L)	>1.0	0.375	0.202
Total Nickel (Ni) (mg/L)	>0.5	0.0039	0.0077
Total Copper (Cu) (mg/L)	>0.01	0.0061	0.056
Total Zinc (Zn) (mg/L)	>0.1	0.0069	0.0094
Total Arsenic (As) (mg/L)	>0.01	0.0028	0.0344
Total Cadmium (Cd) (mg/L)	>0.01	<.0001	<.0001
Total Mercury (Hg) (mg/L)	>0.005	<.0001	0.00013
Total Lead (Pb) (mg/L)	>0.05	<.001	<.001
Total Cyanide (as CN <sup>-</sup> ) (mg/L)	>0.01	<0.001	<0.001
Faecal Coliforms(CFU/100ml)	>100	11,000	>200,000

Note: \* indicates those measurements conducted using in-situ field testing.



**Table 5-9 Results from Analysis of Water Samples from Cipero River**

Parameter	EMA Water Pollution Rules 2001 (as amended) 1st Schedule	Inland		Gulf		Mid-Way
		Dry Season	Wet Season	Dry Season	Wet Season	Wet Season
Temperature (°C)*	Max variation of 3°C from ambient	26.6	26.49	27.58	28.87	27.77
Dissolved Oxygen (DO) (mg/L)*	<4	2.13	4.78	1.08	0.49	0.81
Hydrogen ion (pH)*	Less than 6 or greater than 9	7.46	7.51	7.98	6.78	6.93
Five day Biological Oxygen Demand (BOD <sub>5</sub> ) (mg/L)	>10	170	> 479	43	350	416
Chemical Oxygen Demand (COD) (mg/L)	>60	380	1060	113	799	827
Total Suspended Solids (TSS) (mg/L)	>15	38	69	43	704	67
Ammonia (as N) (mg/L)	>0.01	0.09	0.067	9.01	0.163	0.052
Nitrate (as N) (mg/L)	No limit	<0.1	<0.1	<1	<10	<0.1
Total Phosphorus (as P) (mg/L)	>0.1	0.333	0.137	2.25	1.46	0.148
Total Chromium (Cr) (mg/L)	>0.1	0.0024	0.011	0.0028	0.0112	0.0086
Dissolved Iron (Fe) (mg/L)	>1.0	3.66	1.2	1.6	9.47	1.9
Total Nickel (Ni) (mg/L)	>0.5	0.0037	0.005	0.0078	0.0089	0.0049
Total Copper (Cu) (mg/L)	>0.01	0.0102	0.0088	0.0438	0.0394	0.008
Total Zinc (Zn) (mg/L)	>0.1	0.0148	0.0173	0.0314	0.0206	0.0155
Total Arsenic (As) (mg/L)	>0.01	0.0041	0.003	0.0257	0.0133	0.0029
Total Cadmium (Cd) (mg/L)	>0.01	<.0001	<.0001	<.0001	<.0001	<.0001
Total Mercury (Hg) (mg/L)	>0.005	<.0001	<.0001	<.0001	<.0001	<.0001
Total Lead (Pb) (mg/L)	>0.05	<.001	<.001	<.001	<.001	<.001
Total Cyanide (as CN <sup>-</sup> ) (mg/L)	>0.01	<0.001	<0.001	<0.001	<0.001	<0.001
Faecal Coliforms (CFU/100ml)	>100	179,000	198,000	120,000	>200,000	>200,000

Note: \* indicates those measurements conducted using in-situ field testing.

**Table 5-10 Results from Analysis of Water Samples from Ally's Creek**

Parameter	EMA Water Pollution Rules 2001 (as amended) 1st Schedule	Wet Season
Temperature (°C)*	Max variation of 3°C from ambient	29.6
Dissolved Oxygen (DO) (mg/L)*	<4	4.35
Hydrogen ion (pH)*	Less than 6 or greater than 9	7.72
Five day Biological Oxygen Demand (BOD <sub>5</sub> ) (mg/L)	>10	22
Chemical Oxygen Demand (COD) (mg/L)	>60	38
Total Suspended Solids (TSS) (mg/L)	>15	10
Ammonia (as N) (mg/L)	>0.01	2.34
Nitrate (as N) (mg/L)	No limit	0.22
Total Phosphorus (as P) (mg/L)	>0.1	0.801
Total Chromium (Cr) (mg/L)	>0.1	0.0049
Dissolved Iron (Fe) (mg/L)	>1.0	0.269
Total Nickel (Ni) (mg/L)	>0.5	0.0037
Total Copper (Cu) (mg/L)	>0.01	0.0048
Total Zinc (Zn) (mg/L)	>0.1	0.0297
Total Arsenic (As) (mg/L)	>0.01	0.0028
Total Cadmium (Cd) (mg/L)	>0.01	<.0001
Total Mercury (Hg) (mg/L)	>0.005	<.0001
Total Lead (Pb) (mg/L)	>0.05	<.001
Total Cyanide (as CN <sup>-</sup> ) (mg/L)	>0.01	0.0118
Faecal Coliforms (CFU/ 100ml)	>100	112000

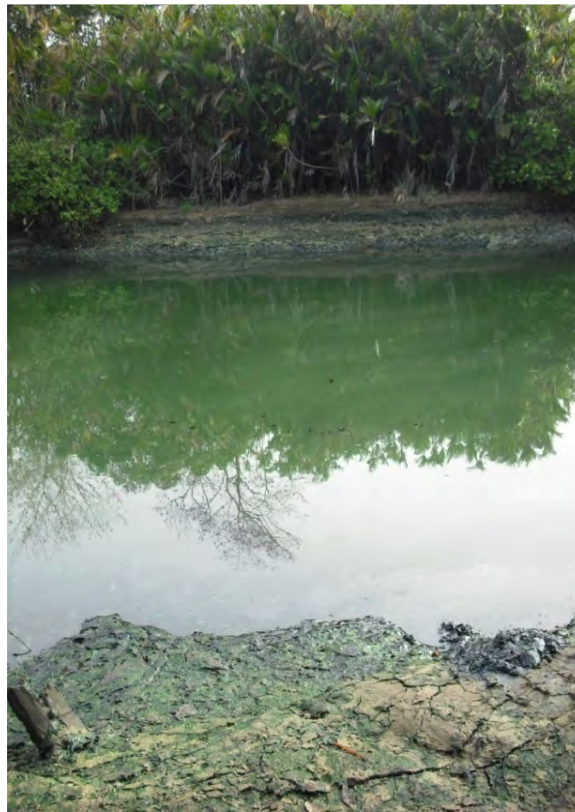
Note: \* indicates those measurements conducted using in-situ field testing.

Photos illustrating the sampling locations accessed included as Figure 5-17 through Figure 5-25.

In order to determine the effect on the river quality as it passes through the San Fernando catchment, the upstream (inland) samples have been compared to the to the downstream (gulf) samples. While the Cipro River BOD<sub>5</sub> and COD values showed an increase in quality (as demonstrated by a decrease in the parameter value) in both the wet and dry season sampling, there were several parameters that decreased in quality, in all rivers sampled. These parameters have been highlighted in Table 5-11.



**Figure 5-17 Guaracara River Upstream Sampling Location**



**Figure 5-18 Guaracara River Downstream Sampling Location**



**Figure 5-19 Marabella River Upstream Sampling Location**



**Figure 5-20 Marabella River Gulf Sampling Location**





**Figure 5-21 Vistabella River Upstream Sampling Location**



**Figure 5-22 Vistabella River Downstream Sample Location**



**Figure 5-23 Ciperu River Upstream Sampling Location**



**Figure 5-24 Ciperu River Downstream Sampling Location**

**Figure 5-25 Ally's Creek Sampling Location****Table 5-11 Water Quality Parameters That Decreased in Quality within the Catchment**

Guaracara River	Marabella River	Vistabella River	Cipero River
Dissolved Oxygen	Dissolved Oxygen	Dissolved Oxygen	Dissolved Oxygen
BOD <sub>5</sub>	BOD <sub>5</sub>	BOD <sub>5</sub>	Ammonia
COD	COD	COD	Total Phosphorus
TSS	TSS	Ammonia	Faecal Coliforms
Ammonia	Ammonia	Faecal Coliforms	
Total Phosphorus	Total Phosphorus		
Dissolved Iron	Dissolved Iron		
Total Copper	Total Copper		
Faecal Coliforms	Total Arsenic		
	Faecal Coliforms		

A description of these parameters and suggestions at how they are appearing in the river systems follows:

### 5.8.1 Faecal Coliforms

Coliform bacteria are a key indicator commonly used to indicate suitability of water for domestic, recreational, or other uses. The presence of these organisms in water is a good indication of pollution arising from wastes of humans, farm animals, and soil erosion. Faecal Coliforms are a subset of the total Coliform group, and refer to the Coliform bacteria that originate from human faeces or other



warm-blooded animals. Typical compositions of untreated domestic wastewater will have between 1,000 and 1,000,000 CFU/100 ml faecal coliforms (Metcalf, 2003).

All water quality results indicate high levels of Faecal Coliforms at all sites, which indicates that raw sewage is entering the river systems, and increasing as it passes through the San Fernando Catchment. As a result of these elevated bacteria levels, these rivers are not fit for recreational purposes, when compared to the:

- First Schedule of the EMA Water Pollution Rules 2001 (as amended) where a pollutant is defined >100 count/100ml;
- Canadian Recreational Water Quality Guidelines (Minister of National Health and Welfare, 1992) where > 2000 E.Coli<sup>1</sup> /L is considered unsafe for recreational use.

### 5.8.2 BOD<sub>5</sub> and COD

Biochemical Oxygen Demand (BOD) and Chemical Oxygen Demand (COD) are parameters used as general indicators of water quality. BOD measures the oxygen demand that biological organisms in the water exert in the biological oxidation of organic matter in a sample. BOD<sub>5</sub> is a standard test conducted over a 5 day incubation period. COD measures the amount of oxygen used in the chemical oxidation of organic matter in a sample.

High BOD and COD values indicate that there are large populations of microorganisms, and organic matter in the water. As the oxygen demand is high, this usually correlates with low dissolved oxygen levels.

Untreated domestic, industrial and sewage effluents will result in high BOD and COD values.

### 5.8.3 Dissolved Oxygen

Dissolved Oxygen (DO) can be used as an indicator of the health of a river system. Adequate dissolved oxygen levels in water can support aerobic life forms, however if the DO levels drop, the aquatic life is put under stress. High BOD and COD may reduce dissolved oxygen levels. As water temperature increases, the saturation point (DO capacity) decreases.

### 5.8.4 Total Suspended Solids

Total suspended solids (TSS) are all materials, both organic and inorganic which are suspended in the water, including particulate matter, such as silt, clay, and microscopic organisms. Suspended solids can result from erosion, algae growth, or discharges of untreated wastewater. Water high in TSS may have increased temperatures and organic matter, and therefore lower DO, which increases aquatic stresses.

### 5.8.5 Ammonia

Ammonia (NH<sub>3</sub>) is the principal form of toxic ammonia. Wilkes University reports that it has been reported toxic to fresh water organisms at concentrations ranging from 0.53 to 22.8 mg/L, affecting

---

<sup>1</sup> When experience has shown that greater than 90 percent of the fecal coliforms are E.Coli, either fecal coliforms or E.Coli may be determined.



hatching and growth rates. In humans, toxic concentrations may cause loss of equilibrium, convulsions, coma, and death. (Wilkes University, Environmental Engineering and Earth Science Department) The quality of water may be affected by Ammonia's presence. Ammonia is used in fertilizers; animal feed production, and may originate from sewage and the degradation of organic nitrogen materials. In the case of fertilizers and wastes containing inorganic and organic nitrogen, decomposition into ammonia usually occurs first. This increase in ammonia in the San Fernando area is expected to occur because of the 'grey water' connections, and other improperly treated sewage entering the river systems.

#### 5.8.6 Total Phosphorus

Phosphorus is an essential element for plant growth and is an abundant mineral found in humans. It is found in fertilizers and some detergents. When erosion occurs, soil particles that contain phosphorus will be eventually released into the water streams. In the environment, phosphorus, in combination with nitrogen, can promote algae blooms.

#### 5.8.7 Metals

Data indicate that dissolved iron, total copper, and total arsenic concentrations increased in the project area. These metals are all naturally occurring in the environment. Low levels of Copper and Iron are usually found in unpolluted surface waters. High levels of copper may be attributed to pesticides, fungicides, feed additives and disinfectants. Iron is used as a construction material, in pipes, in pigments of paints and plastics, and in food colours. Inorganic arsenic occurs naturally in soil and in many kinds of rock, especially in minerals and ore that contains copper or lead.

### 5.9 Biological Environment

The natural ecology of the study area has long ago been altered through a range of anthropogenic activities, primarily sugar cane cultivation, residential development, and quarrying activities at San Fernando Hill. Few natural areas remain. Field studies were conducted on the biological environment in October and November 2009. These studies included flora, aquatic fauna and terrestrial vertebrates. Historical data on the area was also collected to supplement this data.

A land use map for the San Fernando catchment area was established as a means of categorizing natural and artificial habitats.

#### 5.9.1 Land Use of Project Area

A draft land use map was prepared based on satellite images from GoogleEarth™, (© 2007), the 1:25000 topographic map (Lands and Surveys Division, Port of Spain, Trinidad. Sheet No. 53) and a map of proposed developments which was developed by AECOM based on data acquisition from companies, agencies, and field reconnaissance.

The resolution of the satellite image was such that individual houses and trees could be easily recognised as could waterways and ponds. Based on the satellite image the land use was classified into three main categories and an additional six sub-or intermediate categories.



- **Urban Development** – This category includes high density housing, commercial and industrial areas. The image shows almost continuous roofs and buildings
- **Low vegetation with scrub and/or agriculture.** – Such areas are characterised by generally low vegetation with few scattered trees and no structures. **Abandoned sugarcane** fields could be generally identified by their uniform appearance. Some sugarcane may persist in lands not classified as such. Road verges and wasteland also fall into this basic category.
- **Forested areas** - Including mangrove woodland, Riparian forest, silviculture and secondary forest. **Mangrove woodland** was identified by its location on the coast adjacent to river mouths, and narrow strips of trees bordering watercourses were classified as **Riparian vegetation**. Other areas of tree cover were visited to determine their composition.

An intermediate category of **low density housing and agriculture** was assigned to lands where the houses were further apart and small agricultural plots were visible on the image, or seen during field visits.

An overlay of **proposed developments** was applied to the map resulting in an eighth land use category. This included developments at several stages of completion from land clearing to completed structures.

Other features relevant to wildlife include mudflats or sandbars associated with river mouths, the San Fernando Wharf and fishing depot and two National Parks, San Fernando Hill and Palmiste Park.

The initial land use map was verified by two observers, G. White and P. Comeau who conducted field visits over five days at 45 locations within the study area and an additional 10 locations in the wider area. Dates and locations are provided in **Appendix D.3**, G. White's report, Table 1. During these visits the land use was noted, photographed and, when necessary, the land use map was clarified or amended.

The final land use categories (White, 2009) are presented in Figure 5-26 and tabulated in Table 5-13.

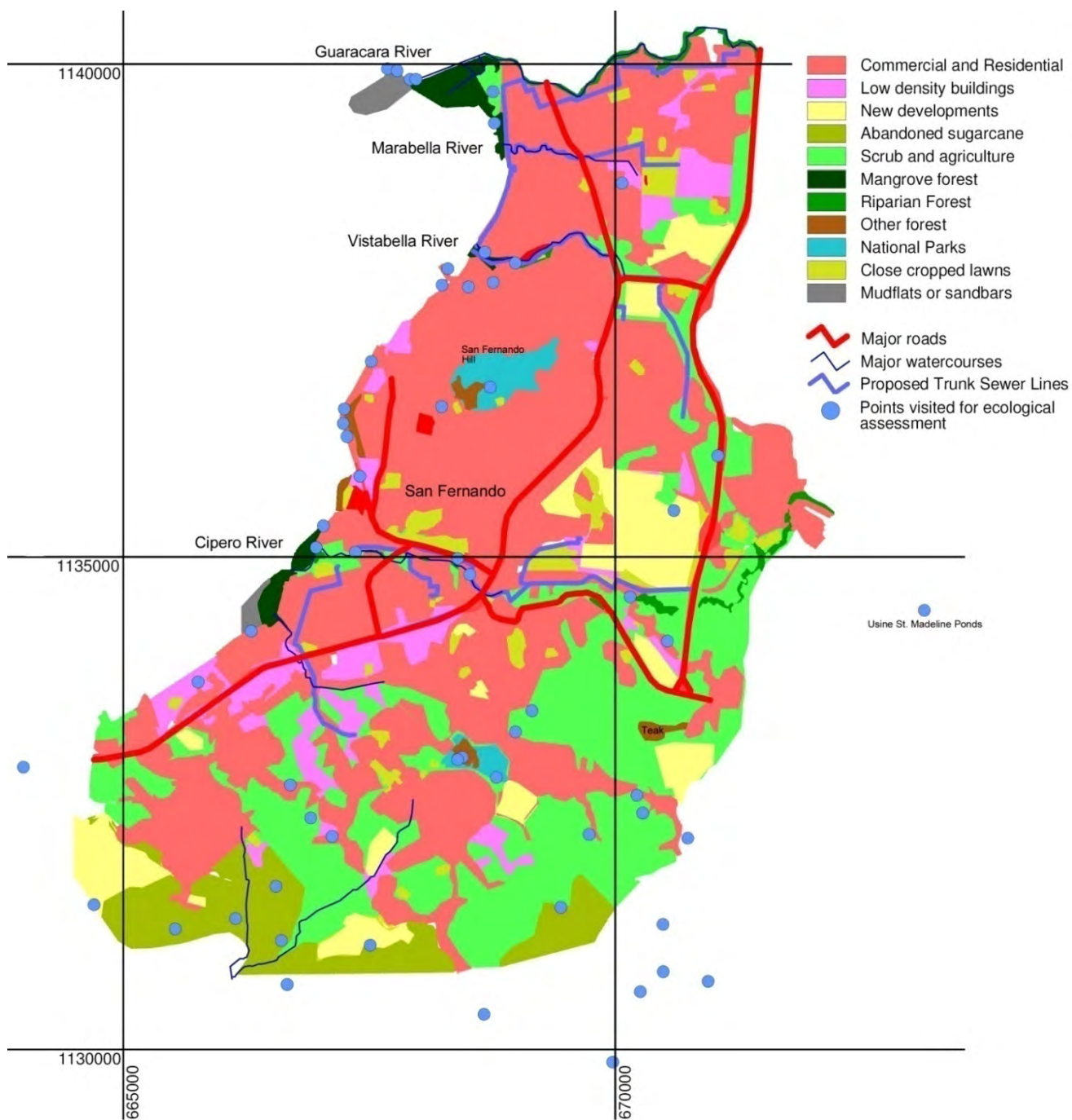


Figure 5-26 Land Use in San Fernando Wastewater Catchment

**Table 5-12 Land Use Categories and Area in San Fernando Wastewater Catchment**

Land Use Category	Area (km <sup>2</sup> )	Percentage of Study Area (%)
Commercial and Residential	8.07	49
Low Density Buildings	0.88	5
New Developments	1.16	7
Abandoned Sugarcane	0.99	6
Scrub and Agriculture	3.63	22
Mangrove Forest	0.21	1
Riparian Forest	0.16	1
National Parks	0.21	1
Close Cropped Lawns	0.49	3
Other	0.8	4
TOTAL	16.6	100

## 5.10 Flora

The field work for this study was carried out at 45 locations within the project area and 10 additional locations in its environs. The report on the flora field work, in its entirety is included in **Appendix D.4**, with the salient points summarized below.

Several centuries ago, the study area was covered by three native forest communities; Crappo-Guatecare-Cocorite, Acurel-Moussara-Carat, and Mora (Marshall, 1934) (Beard, 1946). Today, the only natural remnants are the mangrove trees along the sea shore and the riparian mixed forest further inland both inside and outside of the project boundaries.

The number of observed species has been divided into habitats, as seen in Table 5-13. The recognized habitats observed in this study formed a complex mosaic of plant communities either isolated in small patches, contiguous in others, or as distinctive as the mangrove ecosystem. The flora representation ranged from herbaceous grasses and sedges, common shrubby species such as 'black sage', tree species including palms, exotic fruit trees, introduced timber species for silviculture (teak, cedar, and mahogany), and remnants of native species such as the Silk Cotton tree near the visitor's car park at the San Fernando Boat Club.



**Table 5-13 Observed Habitats and Flora Species Observed**

Habitat	Percentage of Project Area	Species Observed	Comments
Urban Development	49	57	104 species originally recorded by Beard when this project area was originally forest.
Low Vegetation with Scrub and Agriculture	22	57	
Abandoned Sugarcane	6	6	Mainly grasses
Mangrove Woodland	1	17	
Riparian Forest	1	7	Tree species
Silviculture or National Parks	1	5	Dominant tree species included Teak, Samaan, Cedar, Palmist, and Mahogany
Secondary Forest	<3	30	
Road Verges and Wasteland	<3	-	
Low Density Housing and Agriculture	5	6	Dominant species
Proposed Housing Developments	7	-	Mostly barren or sparsely vegetated with several common weeds

As far as possible, the Mangrove Woodland, Riparian Forest and giant Silk Cotton tree should be preserved for future generations to enjoy the diversity offered by these natural habitats or native species. The San Fernando Hill and Palmiste Park were stripped of their natural vegetation but demonstrate good examples of restoration and mitigation of degraded landscapes.

## 5.11 Fauna

### 5.11.1.1 Sites Visited

Terrestrial fauna field visits were conducted over 5 days at 45 locations within the study area, and 10 locations in the wider area. Dates and locations are provided in Figure 5-27.



**Figure 5-27 Dates and Locations of Sites Visited for Terrestrial Fauna Study**

07/10/2009	08/10/2009	13/10/2009	14/10/2009	22/10/2009
670941, 1130692	668729, 1136722	668791, 1132762	668756, 1139721	667685, 1139953
670254, 1130587	667520, 1136983	668445, 1132965	668772, 1139402	667783, 1139934
670485, 1130790	673138, 1134457	668397, 1132942	668675, 1138092	667916, 1139848
670483, 1131270		667122, 1132162	668984, 1137983	667975, 1139848
670734, 1132145		666907, 1132351	668507, 1137739	668235, 1136524
670218, 1132581		666699, 1132684	668298, 1137924	667275, 1136220
670277, 1132400		664705, 1131470	668239, 1137758	667236, 1136354
669972, 1129872		665529, 1131224	668760, 1137785	667246, 1136501
669445, 1131442		666143, 1131330	670068, 1138792	667405, 1135817
669733, 1132183		666552, 1131656		668398, 1134985
669153, 1133438		666607, 1131106		668521, 1134820
668984, 1133224		666666, 1130660		670148, 1134594
666301, 1134246		667510, 1131059		670528, 1134145
663989, 1132866		668665, 1130357		670594, 1135469
665762, 1133731				
667360, 1135047				
666960, 1135095				
667034, 1135315				
671040, 1136026				

Note: Units presented: mE, mN. UTM Zone 20-n. Original coordinates based on Naparima BWI datum and re-registered manually to Naparima 1955.

Specific sites of interest visited for terrestrial fauna observation included:

- Mudflats at Bel Air.
- Boatyard just south of the Vistabella River.
- Mangrove forest around the Guaracara River.
- Freshwater ponds at Usine St. Madeline.
- Ciperó River.
- Forested areas at San Fernando Hill.
- Forested areas at Palmiste Park.

Figures of the some of these sites visited are observed in Figure 5-28 and Figure 5-29.



**Figure 5-28 Cipero River in Concrete Channel at Grid Reference 668521mE, 1134820mN**



**Figure 5-29 Cipero River at Grid Reference 670148mE, 1134594mN**



**Figure 5-30 Mangrove Woodland North of the Guaracara River Accessed via Point-a-Pierre**



**Figure 5-31 Mangrove Woodland South of Guaracara River Mouth**



**Figure 5-32 Mudflats at the Mouth of the Cipro River. Viewed from Bel-Air 666301mE, 1134246mN**



**Figure 5-33 Mudflats at the Mouth of the Vistabella River. Viewed from Boatyard at 668298mE, 1137924mN**

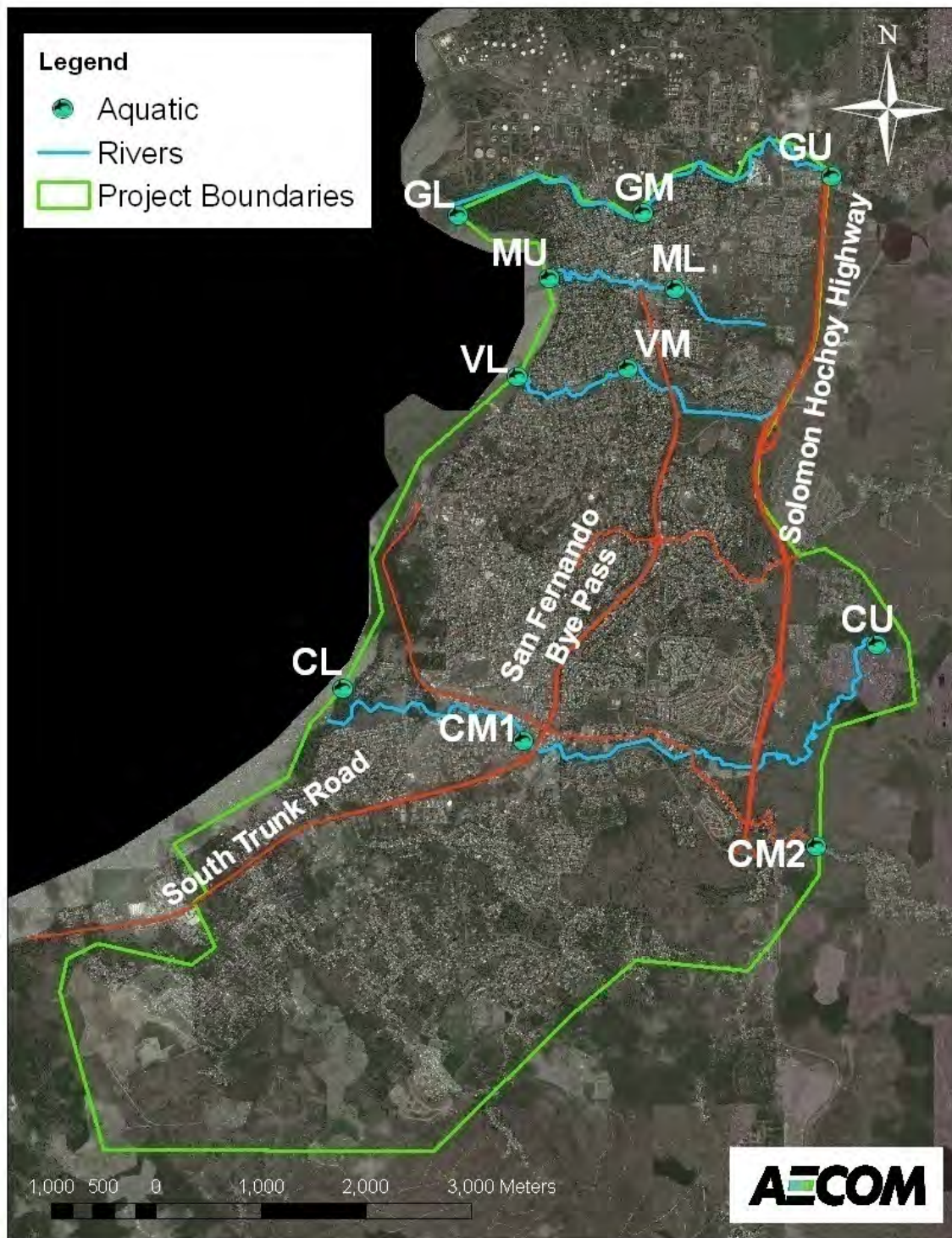


Aquatic fauna field visits were conducted at 13 sample sites in October and November 2009. Two sampling stations were established along the Marabella and Vistabella Rivers, three along Guaracara River and, four along the Ciperó River. Each station represented appropriate segments of the lower, middle and upper courses of the respective river. GPS coordinates of the sites are listed in Table 5-14, and visually displayed in Figure 5-34.

**Table 5-14 Locations Sampled for Aquatic Fauna Study**

Sample Station Name	Sample Station Code	GPS Coordinates	
		Easting	Northing
Cipero Upper	CU	0672327	1135600
Cipero Middle 1	CM1	0668560	1134710
Cipero Middle 2	CM2	0671586	1135040
Cipero Lower	CL	0666834	1135199
Marabella Upper	MU	0670008	1139012
Marabella Lower	ML	0668804	1139119
Vistabella Middle	VM	0669559	1138262
Vistabella Lower	VL	0668506	1138181
Guaracara Upper	GU	0671499	1140088
Guaracara Middle	GM	0669699	1139736
Guaracara Lower	GL	0667941	1139715
Godineau Middle	GoM	0661903	1131179
Godineau Lower	GoL	0661449	1131676

Note: Coordinates based on UTM Zone 20N, WGS 1984



\*\*Note: C- Ciperó River, G – Guaracará River, M- Marabellá River, V- Vistabellá River U – Upper, M – Middle, L – Lower

**Figure 5-34 Sampling Locations for Aquatic Survey**



### 5.11.1.2 Historical Likely Species

The expected fauna (based upon literature review) of the study area is presented in this section. In the case of the birds the land use categories in which they are expected has been identified. For the other classes a general list is provided.

The list of Amphibians and Reptiles potentially in the study area (Table 5-15) includes 64 species. This list is somewhat speculative given the uncertain abundance and distribution of many of these species in Trinidad.

The list of bird species potentially in the study area (Table 5-16) includes 174 of the 444 species recorded from Trinidad. The highest number of species (120) is likely to occur in the coastal environments. 101 species are listed for the Scrub and Agriculture of which 41 species may be found in the urban areas. Of the 174 species 115 are resident in Trinidad and a further 7 regularly breed. Regular seasonal migration from the north or south is exhibited by 51 species. The migrating species mainly comprise seabirds and shorebirds that utilize the coastal environment.

Within the study area there are potentially 29 mammals (Table 5-17), inclusive of 19 Bat species. This is a low proportion of the mammals of Trinidad as is expected for such an area with little natural habitat. The Silky or Two-toed Anteater, *Cyclopes didactylus* may be present as well since there is a likely population in the Godineau Swamp to the south. The Agouti, *Dasyprocta agouti* is also included on the list as there is a remote possibility of a small population in the forest or residential areas around San Fernando Hill.

The larger rivers within the study area have been well surveyed over the years and are known to support a great diversity of aquatic fauna. Table 5-18 provides aquatic fauna species identified within the study area during historical surveys.

For all taxa, additional species are possible since rare species have not been included unless they have been recorded from the area. A list of butterflies likely to occur in the study area (Table 5-19) includes 12 families, with 62 total species. This list excludes the Family HesperIIDae and those species which tend to be restricted to the north or south of Trinidad.





**Table 5-15 Amphibians and Reptiles Which May be Expected Within San Fernando and Environs**

Family	Order	Habitat & Abundance		Residential	Scrub &* Agriculture	Mangrove
	<b>Order Anura</b>					
Brachycephalidae	<i>Eleutherodactylus urichi</i>	RE	C		X	
Bufonidae	<i>Rhinella beebei</i>	S	C	X	X	
	<i>Rhinella marinus</i>	RES	C	X	X	X
Hylidae	<i>Dendropsophus microcephala misera</i>	S	FC	X	X	
	<i>Dendropsophus minutes</i>	RES	FC		X	
	<i>Hypsiboas crepitans</i>	ES	C	X	X	
	<i>Hypsiboas geographicus</i>	RE	FC		X	
	<i>Hypsiboas punctata</i>	RES	FC		X	
	<i>Phyllomedusa trinitatis</i>	RES	FC		X	
	<i>Pseudis paradoxa caribensis</i>	S-Aq			X	
	<i>Scinax rubra</i>	S	FC	X	X	
	<i>Sphaenorhynchus lacteus</i>	ES	FC		X	
	<i>Trachycephalus venulosus</i>	ES	FC		X	
Leptodactylidae	<i>Leptodactylus bolivianus</i>	S	FC		X	
	<i>Loptodactylus fuscus</i>	S	C	X	X	
	<i>Leptodactylus hylaedactyla</i>	RE			Possible	
	<i>Loptodactylus validus</i>	RES	R	X	X	
Leiuperidae	<i>Engystomops pustulosus</i>	S	C	X	X	
Microhylidae	<i>Elachistocleis ovalis</i>	S	FC		Possible	
	<b>Order Chelonia</b>					
Geoemyidae	<i>Rhinoclemmys punctularia punctularia</i>	RES Aq	C		X	
Kinosternidae	<i>Kinosternon scorpioides scorpioides</i>	RES Aq	C		X	
	<b>Order Crocodylia</b>					
Alligatoridae	<i>Caiman crocodilus crocodiles</i>	RES Aq	C		X	X
	<b>Order Squamata: Suborder Sauria</b>					
Amphisbaenidae	<i>Amphisbaena alba</i>	RE	UC			
	<i>Amphisbaena fuliginosa fuliginosa</i>	RES	UC		X	
Gekkonidae	<i>Gonatodes vittatus vittatus</i>	ES	C	X	X	
	<i>Hemidactylus mabouia</i>	U	C	X	X	
	<i>Hemidactylus palaichthus</i>	ES		X	X	



**Table 5-15 Amphibians and Reptiles Which May be Expected Within San Fernando and Environs (continued)**

Family	Order	Habitat & Abundance		Residential	Scrub &* Agriculture	Mangrove
	<i>Sphaerodactylus molei</i>	E	UC	X	X	
	<i>Thecadactylus rapicauda</i>	RES	UC	X	X	
Gymnophthalmidae	<i>Bachia heteropa trinitatis</i>	RE	UC	X	X	
	<i>Gymnophthalmus underwoodi</i>	ES	C			
Iguanidae	<i>Iguana iguana</i>	RES	C	X	X	
Polycrotidae	<i>Anolis aeneus</i>	I,U	C			
	<i>Anolis trinitatis</i>	I,U	R	X		
	<i>Polychrus marmoratus</i>	E	C	X	X	
Scincisae	<i>Mabuya nigropunctata</i>	RE	UC	X	X	
Teiidae	<i>Ameiva ameiva</i>	RES	C	X	X	
	<i>Kentropyx striatus</i>	ES	UC		X	X
	<i>Tupinambis teguixin</i>	RES	C		X	
	<b>Order Squamata: Suborder Serpentes</b>					
Boidae	<i>Boa constrictor constrictor</i>	RES	C		X	
	<i>Corallus ruschbergerii</i>	ES	FC	X	X	X
	<i>Epicrates cenchria maurus</i>	ES	FC		X	
	<i>Eunectes murinus</i>	RES-Aq	FC		X	
Colubridae	<i>Chironius carinatus</i>	RE	FC		X	
	<i>Leptophis ahaetulla coeruleodorsus</i>	RE	C	X	X	
	<i>Mastigodryas boddaerti dunni</i>	ES	C		X	
	<i>Oxybelis aeneus</i>	RES	C	X	X	
Dipsadidae	<i>Attractus trilineatus</i>	RES	C	X	X	
	<i>Dipsas variegata trinitatis</i>	RE	UC		X	
	<i>Leptodeira annulata ashmeadi</i>	RES	C	X	X	
	<i>Ninia atrata</i>	RES	C		X	
	<i>Sibon nebulata nebulata</i>	RES	C	X	X	
Xenodontinae	<i>Clelia clelia clelia</i>	RES	UC			
	<i>Helicops angulatus</i>	RE	FC		X	
	<i>Hydrops triangularis neglectus</i>	RES-Aq	FC		X	X
	<i>Liophis cobella cobella</i>	RES-Aq	C		X	X



**Table 5-15 Amphibians and Reptiles Which May be Expected Within San Fernando and Environs (continued)**

Family	Order	Habitat & Abundance		Residential	Scrub &* Agriculture	Mangrove
	<i>Liophis melanotus nesos</i>	ES	C	X	X	
	<i>Liophis reginae zweifeli</i>	RE	UC	X	X	
	<i>Oxyrhopus petola petola</i>	RES	UC	X	X	
	<i>Pseudoboa newiedii</i>	RES	FC	X	X	
	<i>Spilotes pullatus pullatus</i>	RE	C		X	
	<i>Tantilla melanocephala</i>	RE	FC		X	
Elapidae	<i>Micrurus cercinalis</i>	RES	C		X	
Loptotyphlopidae	<i>Leptotyphlops albifrons</i>	RE	C	X	X	

Note: \* The category Scrub and Agriculture includes wet grasslands and earth-lined canals

Taxonomy based on Murphy (2008)

Habitat and distribution based on Murphy (1997) R- Rainforest E- Forest Edge S- Savannah Aq – Aquatic

Abundance based on Boos 1984 C- Common, FC- Fairly Common, UC - Uncommon R – Rare

**Table 5-16 Birds of Trinidad Likely to be Found Within San Fernando and Environs and the Habitats in Which They are Likely to be Found**

Species	Status & Abundance		Residential	Coastal	Scrub and agriculture	Other
Pelicanidae						
Brown Pelican, <i>Pelicanus occidentalis</i>	BR	A		X		
Phalacrocoracidae						
Neotropic Cormorant, <i>Phalacrocorax brasilianus</i>	MS	C		X		
Anhingidae						
Anhinga, <i>Anhinga anhinga</i>	MS	U		X		
Fregatidae						
Magnificent Frigatebird, <i>Fregata magnificens</i>	BR	C		X		
Ardeidae						
Boat-billed Heron, <i>Cochlearius cochlearius</i>	BR	R		X		
Black-crowned Night-heron, <i>Nycticorax nycticorax</i>	BR	C		X	X	
Yellow-crowned Night-heron, <i>Nyctanassa violacea</i>	BR	C		X		
Striated Heron, <i>Butorides striatus</i>	BR	C		X	X	
Cattle Egret, <i>Bubulcus ibis</i>	BR	A		X	X	



**Table 5-16 Birds of Trinidad Likely to be Found Within San Fernando and Environs and the Habitats in Which They are Likely to be Found (continued)**

Species	Status & Abundance		Residential	Coastal	Scrub and agriculture	Other
Great Blue Heron, <i>Ardea herodias</i>	MN	U		X		
Cocoi Heron, <i>Ardea cocoi</i>	MS	Sc		X		
Great Egret, <i>Ardea alba</i>	BV	C		X		
Tricolored Heron, <i>Egretta tricolor</i>	BV	C		X		
Snowy Egret, <i>Egretta thula</i>	BV	A		X	X	
Little Blue Heron, <i>Egretta caerulea</i>	BV	A		X		
Threskiornithidae						
Scarlet Ibis, <i>Eudocimus ruber</i>	BV	L		X		
Cathartidae						
Turkey Vulture, <i>Cathartes aura</i>	BR	A			X	
Black Vulture, <i>Coragyps atratus</i>	BR	A		X	X	
Phoenicopteridae						
Greater Flamingo, <i>Phoenicopterus ruber</i>	MS	R		X		
Accipitridae						
Osprey, <i>Pandion haliaetus</i>	MN	C		X		
Pearl Kite, <i>Gampsonyx swainsonii</i>	BR	U			X	
Long-winged Harrier, <i>Circus buffoni</i>	BR	U			X	
Grey Hawk, <i>Asturina nitida</i>	BR	C	X		X	
Common Black-hawk, <i>Buteogallus anthracinus</i>	BR	C		X	X	
Rufous Crab-hawk, <i>Buteogallus aequinoctialis</i>	BR	R		X		
Savannah Hawk, <i>Buteogallus meridionalis</i>	BR	C			X	
Short-tailed Hawk, <i>Buteo brachyurus</i>	BR	C			X	
Zone-tailed Hawk, <i>Buteo albonotatus</i>	BR	C			X	
Falconidae			X			
Yellow-headed Caracara, <i>Milvago chimachima</i>	BR	C	X	X	X	
Merlin, <i>Falco columbarius</i>	MN	U	X	X	X	
Aplomado Falcon, <i>Falco femoralis</i>	MS	R		X		
Bat Falcon, <i>Falco rufifigularis</i>	BR	Sc			X	
Peregrine Falcon, <i>Falco peregrinus</i>	MN	U	X	X	X	
Aramidae						
Limpkin, <i>Aramus guarauna</i>	BR	U			X	
Rallidae						



**Table 5-16 Birds of Trinidad Likely to be Found Within San Fernando and Environs and the Habitats in Which They are Likely to be Found (continued)**

Species	Status & Abundance		Residential	Coastal	Scrub and agriculture	Other
Clapper Rail, <i>Rallus longirostris</i>	BR	L		X		
Grey-necked Wood-rail, <i>Aramides cajanea</i>	BR	-			X	
Common Moorhen, <i>Gallinula chloropus</i>	BR	C				Marsh
Purple Gallinule, <i>Porphyrio martinica</i>	BR	C				Marsh
Charadriidae						
Southern Lapwing, <i>Vanellus chilensis</i>	BR	A		X	X	
American Golden-Plover, <i>Pluvialis dominica</i>	MN	U				Lawns
Black-bellied Plover, <i>Pluvialis squatarola</i>	MN	C		X		
Semipalmated Plover, <i>Charadrius semipalmatus</i>	MN	C		X		
Wilson's Plover, <i>Charadrius wilsonia</i>	MS	U		X		
Collared Plover, <i>Charadrius collaris</i>	BD	C		X		
Recurvirostridae						
Black-necked Stilt, <i>Himantopus mexicanus</i>	BD	C		X		
Scolopacidae						
Short-billed Dowitcher, <i>Limnodromus griseus</i>	MN	C		X		
Hudsonian Godwit, <i>Limosa haemastica</i>	MN	Sc		X		
Marbled Godwit, <i>Limosa fedoa</i>	MN	R		X		
Whimbrel, <i>Numenius phaeopus</i>	MN	C		X		
Greater Yellowlegs, <i>Tringa melanoleuca</i>	MN	C		X		
Lesser Yellowlegs, <i>Tringa flavipes</i>	MN	A		X		
Solitary Sandpiper, <i>Tringa solitaria</i>	MN	C		X		
Willet, <i>Catoptrophorus semipalmatus</i>	MN	C		X		
Spotted Sandpiper, <i>Actitis macularia</i>	MN	C		X		
Ruddy Turnstone, <i>Arenaria interpres</i>	MN	C		X		
Red Knot, <i>Calidris canutus</i>	MN	U		X		
Sanderling, <i>Calidris alba</i>	MN	U		X		



**Table 5-16 Birds of Trinidad Likely to be Found Within San Fernando and Environs and the Habitats in Which They are Likely to be Found (continued)**

Species	Status & Abundance		Residential	Coastal	Scrub and agriculture	Other
Semipalmated Sandpiper, <i>Calidris pusilla</i>	MN	A		X		
Western Sandpiper, <i>Calidris mauri</i>	MN	A		X		
Least Sandpiper, <i>Calidris minutilla</i>	MN	A		X		
White-rumped Sandpiper, <i>Calidris fuscicollis</i>	MN	U		X		
Pectoral Sandpiper, <i>Calidris melanotos</i>	MN	U				Lawns
Stilt Sandpiper, <i>Calidris himantopus</i>	MN	C		X		
Jacanidae						
Wattled Jacana, <i>Jacana jacana</i>	BR	A				Marsh
Stercorariidae						
Parasitic Jaeger, <i>Stercorarius parasiticus</i>	O	Sc		X		
Laridae						
Ring-billed Gull, <i>Larus delawarensis</i>	MN	R		X		
Lesser Black-backed Gull, <i>Larus fuscus</i>	MN	U		X		
Kelp Gull, <i>Larus dominicanus</i>	MN	VR				
Herring Gull, <i>Larus argentatus</i>	V	VR				
Laughing Gull, <i>Larus atricilla</i>	BV	A		X		
Franklin's Gull, <i>Larus pipixcan</i>	MN	VR				
Sabine's Gull, <i>Xema sabini</i>	W	VR				
Gull-billed Tern, <i>Sterna nilotica</i>	MN	U		X		
Sandwich Tern, <i>Sterna sandvicensis</i>	MN/S	U		X		
Royal Tern, <i>Sterna maxima</i>	MN(B)	C		X		
Common Tern, <i>Sterna hirundo</i>	MN	C		X		
Yellow-billed Tern, <i>Sterna superciliaris</i>	MS	C		X		
Black Tern, <i>Chlidonias niger</i>	MN	Sc		X		
Large-billed Tern, <i>Phaetusa simplex</i>	MS	C		X		
Black Skimmer, <i>Rynchops niger</i>	MS	C		X		
Columbidae						
Common Ground-dove, <i>Columbina passerina</i>	BR	C			X	
Plain-breasted Ground-dove, <i>Columbina minuta</i>	BR	U			X	



**Table 5-16 Birds of Trinidad Likely to be Found Within San Fernando and Environs and the Habitats in Which They are Likely to be Found (continued)**

Species	Status & Abundance		Residential	Coastal	Scrub and agriculture	Other
Ruddy Ground-dove, <i>Columbina talpacoti</i>	BR	A	X		X	
Rock Dove, <i>Columba livia</i>	Feral	A	X		X	
Eared Dove, <i>Zenaida auriculata</i>	BD	C		X	X	
White-tipped Dove, <i>Leptotila verreauxi</i>	BR	C	X		X	
Psittacidae						
Green-rumped Parrotlet, <i>Forpus passerinus</i>	BR	U	X	X	X	
Yellow-crowned Parrot, <i>Amazona ochrocephala</i>	BR	C	X		X	
Orange-winged Parrot, <i>Amazona amazonica</i>	BR	A		X	X	
Cuculidae						
Mangrove Cuckoo, <i>Coccyzus minor</i>	BR	Sc		X		
Greater Ani, <i>Crotophaga major</i>	BR	U		X	X	
Smooth-billed Ani, <i>Crotophaga ani</i>	BR	A	X	X	X	
Striped Cuckoo, <i>Tapera naevia</i>	BR	C		X	X	
Tytonidae						
Barn Owl, <i>Tyto alba</i>	BR	U	X	X	X	
Strigidae						
Tropical Screech-owl, <i>Megascops choliba</i>	BR	U	X		X	
Ferruginous Pygmy-owl, <i>Glaucidium brasilianum</i>	BR	C	X		X	
Nyctibiidae						
Common Potoo, <i>Nyctibius griseus</i>	BR	U		X		
Caprimulgidae						
Lesser Nighthawk, <i>Chordeiles acutipennis</i>	MN	C		X	X	
Nacunda Nighthawk, <i>Podager nacunda</i>	MS	Sc			X	
Common Pauraque, <i>Nyctidromus albicollis</i>	BR	C			X	
White-tailed Nightjar, <i>Caprimulgus cayennensis</i>	BR	C			X	
Apodidae						



**Table 5-16 Birds of Trinidad Likely to be Found Within San Fernando and Environs and the Habitats in Which They are Likely to be Found (continued)**

Species	Status & Abundance		Residential	Coastal	Scrub and agriculture	Other
Short-tailed Swift, <i>Chaetura brachyura</i>	BR	A	X		X	
Fork-tailed Palm-swift, <i>Tachornis squamata</i>	BR	C			X	
Trochilidae						
Rufous-breasted Hermit, <i>Glaucis hirsutus</i>	BR	C				Forest
Little Hermit, <i>Phaethornis longuemareus</i>	BR	C				Forest
Green-throated Mango, <i>Anthracothorax viridigula</i>	BR	L		X		
Ruby-topaz Hummingbird, <i>Chrysolampis mosquitus</i>	BD	C	X	X	X	
Tufted Coquette, <i>Lophornis ornat</i>	BR	U			X	
White-chested Emerald, <i>Amazilia brevirostris</i>	BR	C		X	X	
Copper-rumped Hummingbird, <i>Amazilia tobaci</i>	BR	A	X	X	X	
Long-billed Starthroat, <i>Heliomaster longirostris</i>	BR	Sc		X		
Alcedinidae						
Ringed Kingfisher, <i>Ceryle torquata</i>	BR	U		X		
Green Kingfisher, <i>Chloroceryle Americana</i>	BR	C		X		
Pygmy Kingfisher, <i>Chloroceryle aenea</i>	BR	U		X		
Picidae						
Lineated Woodpecker, <i>Dryocopus lineatus</i>	BR	C	X		X	
Furnariidae						
Pale-breasted Spinetail, <i>Synallaxis albescens</i>	BR	U			X	
Yellow-chinned Spinetail, <i>Certhiaxis cinnamomea</i>	BR	C			X	
Dendrocolaptidae						
Straight-billed Woodcreeper, <i>Xiphorhynchus picus</i>	BR	L		X		
Thamnophilidae						





**Table 5-16 Birds of Trinidad Likely to be Found Within San Fernando and Environs and the Habitats in Which They are Likely to be Found (continued)**

Species	Status & Abundance		Residential	Coastal	Scrub and agriculture	Other
Black-crested Antshrike, <i>Sakesphorus Canadensis</i>	BR	C		X		
Barred Antshrike, <i>Thamnophilus doliatus</i>	BR	C	X		X	
Tyrannidae						
Yellow-bellied Elaenia, <i>Elaenia flavogaster</i>	BR	C	X	X	X	
Southern Beardless Tyrannulet, <i>Camptostoma obsoletum</i>	BR	C			X	
Northern scrub Flycatcher, <i>Sublegatus arenarum</i>	BR	U		X		
Yellow-breasted Flycatcher, <i>Tolmomyias flavivrentris</i>	BR	C		X		
Bran-colored Flycatcher, <i>Myiophobus fasciatus</i>	BR	U		X	X	
Pied Water-tyrant, <i>Fluvicola pica</i>	BR	C		X	X	
White-headed Marsh-tyrant, <i>Arundinicola leucocephala</i>	BR	C		X	X	
Piratic Flycatcher, <i>Legatus leucophaius</i>	BD	C			X	
Great Kiskadee, <i>Pitangus sulphuratus</i>	BR	A	X	X	X	
Streaked Flycatcher, <i>Myiodynastes maculates</i>	BR	C			X	
Boat-billed Flycatcher, <i>Megarynchus pitangua</i>	BR	C		X	X	
Tropical Kingbird, <i>Tyrannus melancholicus</i>	BR	A	X	X	X	
Fork-tailed Flycatcher, <i>Tyrannus savanna</i>	MS	A		X	X	
Grey Kingbird, <i>Tyrannus dominicensis</i>	BV	U		X	X	
Brown-crested Flycatcher, <i>Myiarchus tyrannulus</i>	BR	U		X		
White-winged Becard, <i>Pachyramphus polychopterus</i>	BR	U		X		
Vireonidae						
Rufous-browed Peppershrike, <i>Cyclarhis gujanensis</i>	BR	C	X	X	X	



**Table 5-16 Birds of Trinidad Likely to be Found Within San Fernando and Environs and the Habitats in Which They are Likely to be Found (continued)**

Species	Status & Abundance		Residential	Coastal	Scrub and agriculture	Other
Red-eyed Vireo, <i>Vireo olivaceus</i>	BV	C		X	X	
Golden-fronted Greenlet, <i>Hylophilus aurantiifrons</i>	BR	C		X	X	
Hirundinidae						
White-winged Swallow, <i>Tachycineta albiventer</i>	BR	C	X	X	X	
Grey-breasted Martin, <i>Progne chalybea</i>	BR	A	X	X	X	
Blue and White Swallow, <i>Pygochelidon cyanoleuca</i>	MS	U		X	X	
Southern Rough-winged Swallow, <i>Stelgidopteryx ruficollis</i>	BR	C			X	
Barn Swallow, <i>Hirundo rustica</i>	MN	C		X	X	
Bank Swallow, <i>Riparia riparia</i>	MN	Sc			X	
Troglodytidae						
House Wren, <i>Troglodytes aedon</i>	BR	C	X	X	X	
Rufous-breasted Wren, <i>Thryothorus rutilus</i>	BR	C			X	
Sylviidae						
Long-billed Gnat-wren, <i>Ramphocaenus melanurus</i>	BR	C		X	X	
Turdidae						
Bare-eyed Robin, <i>Turdus nudigenis</i>	BR	C	X	X	X	
Cocoa Thrush, <i>Turdus fumigatus</i>	BR	C				Forest
Mimidae						
Tropical Mockingbird, <i>Mimus gilvus</i>	BR	C	X	X	X	
Coerebidae						
A Bananaquit, <i>Coereba flaveola</i>	BR	A	X	X	X	
Thraupidae						
White-shouldered Tanager, <i>Tachyphonus luctuosus</i>	BR	U			X	
White-lined Tanager, <i>Tachyphonus rufus</i>	BR	C	X		X	
Silver-beaked Tanager, <i>Ramphocelus carbo</i>	BR	C	X		X	
Blue-grey Tanager, <i>Thraupis episcopus</i>	BR	C	X	X	X	
Palm Tanager, <i>Thraupis palmarum</i>	BR	A	X	X	X	



**Table 5-16 Birds of Trinidad Likely to be Found Within San Fernando and Environs and the Habitats in Which They are Likely to be Found (continued)**

Species	Status & Abundance		Residential	Coastal	Scrub and agriculture	Other
Turquoise Tanager, <i>Tangara mexicana</i>	BR	C			X	
Bicolored Conebill, <i>Conirostrum bicolor</i>	BR	C		X		
Emberizidae						
Saffron Finch, <i>Sicalis flaveola</i>	BR	U	X		X	
Blue-black Grassquit, <i>Volatinia jacarina</i>	BR	A	X		X	
Red-capped Cardinal, <i>Paroaria gularis</i>	BR	U		X	X	
Cardinalidae			X			
Greyish Saltator, <i>Saltator coerulescens</i>	BR	C	X	X	X	
Dickcissel, <i>Spiza americana</i>	MN	C			X	
Parulidae						
Yellow Warbler, <i>Dendroica petechia</i>	MN	C	X	X	X	
American Redstart, <i>Setophaga ruticilla</i>	MN	C		X	X	
Prothonotary Warbler, <i>Protonotaria citrea</i>	MN	Sc		X		
Northern Waterthrush, <i>Seiurus noveboracensis</i>	MN	C		X	X	
Masked Yellowthroat, <i>Geothlypis aequinoctialis</i>	BR	U			X	
Icteridae						
Crested Oropendola, <i>Psarocolius decumanus</i>	BR	A			X	
Yellow Oriole, <i>Icterus nigrogularis</i>	BR	C	X	X	X	
Giant Cowbird, <i>Molothrus oryzivora</i>	BR	U			X	
Shiny Cowbird, <i>Molothrus bonariensis</i>	BR	A	X	X	X	
Carib Grackle, <i>Quiscalus lugubris</i>	BR	A	X	X	X	
Red-breasted Blackbird, <i>Sturnella militaris</i>	BR	C			X	
Yellow-hooded Blackbird, <i>Chrysomus icterocephalus</i>	BR	A		X	X	Marsh
Euphonidae						



**Table 5-16 Birds of Trinidad Likely to be Found Within San Fernando and Environs and the Habitats in Which They are Likely to be Found (continued)**

Species	Status & Abundance		Residential	Coastal	Scrub and agriculture	Other
	BR	U				
Trinidad Euphonia, <i>Euphonia trinitatis</i>	BR	U		X	X	
Violaceous Euphonia, <i>Euphonia violacea</i>	BR	C			X	
Estrildidae						
Common Waxbill, <i>Estrilda astrild</i>	BR	L			X	

Note: The Coastal habitat includes Mangrove, Mudflats and seabird roosts

Nomenclature (Remsen et al 2007). Status and abundance categories (White et al 2007)

BR Resident species without significant movement out of Trinidad and Tobago. Breeding is assumed even if no nest has been documented.

BD Species that breed locally and migrate or disperse to the mainland (sometimes only partially) in the non-breeding period.

BV Resident, regularly breeding species whose numbers are augmented by visitors from continental N & S America

MN Non-breeding migrants from continental North America. Predominantly over-wintering.

MS Migrants from South America. These species may be avoiding the Austral winter, dispersing from breeding grounds but generally show regular seasonal movements. May occasionally breed.

O Oceanic, may be observed from shore.

W Generally sedentary or wandering species at the edge of their range. Reported less than once per decade.

A Abundant; widespread and usually in some numbers in suitable habitat.

C Common, usually found in suitable habitat.

U Uncommon; occasionally seen in suitable habitat in small numbers or singly.

Sc Scarce, very few (less than 5) records in a year.

R Rare- not recorded annually.

VR Very Rare Less than one record per decade.

L Locally distributed in restricted habitat; but may be not uncommon there



**Table 5-17 Mammals of Trinidad Which May be Expected Within San Fernando and Environs**

Order	Family	Sp Alkins	Common Name
Marsupialia	Didelphidae	<i>Didelphis marsupialis insularis</i>	Black-eared Opossum
Edentata	Myrmecophagidae	<i>Cyclopes didactylus didactylus</i>	Two-toed Anteater
Chiroptera	Emballonuridae	<i>Rhynchiscus naso</i>	Jacob's Ladder Bat
	Emballonuridae	<i>Saccopteryx bilineata perspicillifer</i>	Greater Trinidadian two-lined Bat
	Emballonuridae	<i>Saccopteryx leptura</i>	Lesser two-lined Bat
	Noctilionidae	<i>Noctilio leporinus leporinus</i>	Fish-eating Bat
	Mormoopidae	<i>Chilonycteris rubiginosa fusca</i>	Greater Mustache Bat
	Mormoopidae	<i>Pteronotus davyi davyi</i>	Naked-backed Bat
	Mormoopidae	<i>Mormoops megalophylla tumidiceps</i>	Trinidadian Leaf-chinned Bat
	Phyllostomidae	<i>Micronycteris sp.</i>	Bat
	Phyllostomidae	<i>Phyllostomus hastatus hastatus</i>	Greater Spear-nosed Bat
	Phyllostomidae	<i>Glossophaga soricina soricina</i>	Bat
	Phyllostomidae	<i>Anoura geoffroyi geoffroyi</i>	Tailless Long-tongued Bat
	Phyllostomidae	<i>Carollia perspicillata perspicillata</i>	Short-tailed Fruit Bat
	Phyllostomidae	<i>Sturnira lilium lilium</i>	South American Yellow-shouldered Bat
	Phyllostomidae	<i>Uroderma bilobatum bilobatum</i>	Yellow-eared or Tent Making Bat
	Phyllostomidae	<i>Artibeus jamaicensis trinitatis</i>	Lesser Trinidadian Fruit Bat
	Phyllostomidae	<i>Artibeus lituratus palmarum</i>	Greater Trinidadian Fruit Bat
	Vespertilionidae	<i>Myotis nigricans nigricans</i>	Little Balck Bat
	Molossidae	<i>Molossus ater ater</i>	Large Free-tailed Bat
	Molossidae	<i>Molossus major major</i>	Small Free-tailed Bat
Rodentia	Sciuridae	<i>Sciurus granatensis chapmani</i>	Trinidadian Squirrel
	Muridae	<i>Oryzomys concolor speciosus</i>	Arboreal Rice Rat
	Muridae	<i>Zygodontomys brevicauda brevicauda</i>	Trinidadian Cane Rat
	Muridae	<i>Rattus rattus rattus</i>	Black Rat
	Muridae	<i>Rattus norvegicus</i>	Wharf Rat
	Muridae	<i>Mus musculus brevirostris</i>	House mouse
	Dasyproctidae	<i>Dasyprocta agouti</i>	Agouti
Carnivora	Viverridae	<i>Herpestes auropunctatus</i>	Small Indian Mongoose

Note: \* Taxonomy follows Alkins (1979). Likely list of bats conservative with assistance from Geoffrey Gomes.



**Table 5-18 Historical Records of Aquatic Species Found Within San Fernando and Environs**

Family	Species	Common Name	epas 2005	IMA 2003	Kenny 1995
<i>Fishes</i>					
Achiridae	<i>Trinectes sp</i>	Flat Fish	X		
Anablepidae	<i>Anableps anableps</i>	Four-eyed Fish	X		
Ariidae	<i>Ariopsis bonillai</i> ( <i>Hexanemataichthys spp.</i> )	Catfish	X	X	
	<i>Arius sp.</i>	Catfish	X		
	<i>Cathorops spixii</i>	Catfish	X		
	<i>Rhamdia. quelen</i>	Barbe	X		X
	<i>Pseudochanna obscura</i>	Cocosoda Catfish		X	
Batrachoididae	<i>Batrachoides surinamensis</i>	Crapaud Fish	X	X	
Callichthyidae	<i>Callichthys callichthys</i>	Chato			X
	<i>Corydoras aeneus</i>	Pui-Pui			X
	<i>Hoplosternum littorale</i>	Cascadu		X	X
Carangidae	<i>Caranx hippos</i>	Cavalli		X	
	<i>Chloroscombrus chrysurus</i>	Plateau	X		
	<i>Oligoplites palometa</i>	Zapate	X		
Centropomidae	<i>Centropomus undecimalis</i>	Brochet	X	X	
Cichlidae	<i>Aequidens pulcher</i>	Green Coscorob		X	X
	<i>Cichlasoma taenia</i>	Coscorob			X
	<i>Crenicichia alta</i>	Millet			X
	<i>Oreochromis mossambicus</i>	Tilapia			X
Characidae	<i>Astyanax bimaculats</i>	Sardine Doree		X	X
	<i>Corynopoma riisei</i>	Swordtail Sardine			X
	<i>Hemibrycon</i>			X	
	<i>Hemigrammus unilineatus</i>	Feather Sardine			X
	<i>Megalampodus axelrodi</i>	Riddlei			X
	<i>Roeboides dayi</i>	Glass Sardine		X	
Clupeidae	<i>Harengula jaguna</i>	Hardback Herring	X		
	<i>Odontognathus compressus</i>	Sardine	X		
Cyprinodontidae	<i>Rivulus hartii</i>	Jumping guabine			X
Epinephelinae	<i>Epinephelus itajara</i>	Jewfish		X	
Eleotridae	<i>Dormitator maculatus</i>				X
	<i>Eleptris pisonis</i>	Guabine			X
Ephippidae	<i>Chaetodipterus faber</i>	Paoua	X		
Engraulidae	<i>Anchovia sp.</i>	Jashua	X		
	<i>A. trinitatis</i>	Sardine	X		
	<i>Cetengraulis edentulus</i>	Sardine	X		
Erythrinidae	<i>Hoplias malabaricus</i>	Guabine		X	X
Gerreidae	<i>Diapterus rhombeus</i>	Blinch	X	X	



**Table 5-18 Historical Records of Aquatic Species Found Within San Fernando and Environs (continued)**

Family	Species	Common Name	epas 2005	IMA 2003	Kenny 1995
Gymnotidae	<i>Gymnotus carapo</i>	Cutlass knife			X
Haemulidae	<i>Genyatremus luteus</i>	Trawat		X	
Loricariidae	<i>Hypostomus robinii</i>	Teta		X	X
Lutjanidae	<i>Lutjanus cyanopterus</i>	Grey Snapper		X	
Megalopidae	<i>Megalops atlanticus</i>	Tarpon		X	
Mugilidae	<i>Mugil curema</i>	Mullet	X	X	
	<i>Mugil cephalus</i>			X	
Nandidae	<i>Polycentrus schomburgkii</i>	King Coscarob		X	X
Poeciliidae	<i>Poecilia reticulata</i>	Guppy 7 Colours		X	X
	<i>Poecilia picta</i>	Millions			X
	<i>Poecilia vivipara</i>	Millions			X
Pomadasyidae	<i>Haemulon bonariense</i>	Grunt		X	
Rivulidae	<i>Rivulus hartii</i>	Jumping Guabine			X
Sciaenidae	<i>Cynoscion acoupa</i>	Acoupa Weakfish		X	
	<i>Larimus breviceps</i>	Weiwei	X		
	<i>Macrodon ancyclodon</i>	King Weakfish		X	
	<i>Micropogon furnieri</i>	Racando (Cro cro)	X		
	<i>Ophioscion punctatissimus</i>	Spotted Croaker		X	
	<i>Stellifer</i>			X	
Soleidae	<i>Achirus sp.</i>	Flounder		X	
symbranchidae	<i>Symbranchus marmoratus</i>	Zange			X
<i>Shrimp</i>					
Penaeidae	<i>Penaeus notialis</i>	Red Shrimp	X		
	<i>Penaeus schmitti</i>	White Shrimp (Cork)	X		
	<i>Xiphopenaeus kroyeri</i>	Seabob	X		
<i>Crabs</i>					
Ocypodidae	<i>Uca sp.</i>	Fiddler Crab	X		
Portunidae	<i>Callinectes danae</i>	Blue (Marine) Crab	X		
	<i>Callinectes sapidus</i>	Blue (Marine) Crab	X		



**Table 5-19 Butterfly Species Common or Abundant and Widespread in Trinidad and are Likely to Occur in the Greater San Fernando Area.**

Family	Species
Satyridae	Night, <i>Taygetis virgilia</i>
	Night, <i>Taygetis echo</i>
	Night, <i>Taygetis cleopatra</i>
	Night, <i>Taygetis andromeda</i>
	Night, <i>Taygetis penelea</i>
	Ringlet, <i>Euptychia hesione</i>
	Ringlet, <i>Euptychia terrestris</i>
	Ringlet, <i>Euptychia palladia</i>
	Ringlet, <i>Euptychia penelope</i>
	Ringlet, <i>Euptychia hermes</i>
	Ringlet, <i>Euptychia libye</i>
	Ringlet, <i>Euptychia arnaea</i>
Danaiidae	Monarch, <i>Danaus plexippus megalippe</i>
	Small Lace-Wing, <i>Actinote pellenia trinitatis</i>
Ithomiidae	Tiger, <i>Tithorea harmonia megara</i>
	Sweet oil, <i>Mechanitis isthmia kayei</i>
	Sweet oil, <i>Mechanitis polymnia solaris</i>
	Brown Transparent, <i>Hypoleria ocalea</i>
	Blue Transparent, <i>Ithomia pellucida pellucida</i>
Heliconiade	Blue Grecian, <i>Heliconius wallacei</i>
	Small Blue Grecian, <i>Heliconius sara</i>
	Postman, <i>Heliconius melpomene</i>
	Small Postman, <i>Heliconius erato</i>
	Isabella tiger, <i>Heliconius isabella</i>
	Small Flambeau, <i>Heliconius alipha</i>
	Flambeau, <i>Colaenis iulia</i>
	Scarce Silver-spotted Flambeau, <i>Dione juno</i>
	Silver spotted flambeau, <i>Agraulis vanillae</i>
Nymphalidae	Bamboo Page, <i>Metamorpha stelenes</i>
	Biscuit, <i>Anartia jatrophe</i>
	Coolie, <i>Anartia amathea</i>





**Table 5-19 Butterfly Species Common or Abundant and Widespread in Trinidad and are Likely to Occur in the Greater San Fernando Area.** (continued)

Family	Species
Nymphalidae	Little Soldier, <i>Chlosyne saundersii</i>
	Donkey's Eye, <i>Precis lavinia zonatis</i>
	Handkerchief, <i>Phycoides leucodesma</i>
	Blue-Tinted Handkerchief, <i>Dynamine theseus</i>
	Small Dynamine, <i>Dynamine artemesia</i>
	Grey Handkerchief, <i>Mestra hypermestra cana</i>
	Grey Cracker, <i>Hamadryas ferentina</i>
	Cracker, <i>Hamadryas feronia</i>
	89, <i>Callicore aurelia</i>
	Four-continent, <i>Adelpha iphicla</i>
	Five Continent, <i>Adelpha cytherea</i>
	Zebra, <i>Colobura dirce</i>
Morphidae	Morpho, <i>Morpho peleides insularis</i>
Brassolidae	Cattle Heart, <i>Parides anchises cymocles</i>
Papilionidae	Spear-Winged Cattle Heart, <i>Parides neophilus parianus</i>
	King Page, <i>Papilio thoas nealces</i>
	Small King Page, <i>Papilio homothoas</i>
Peridae	Common Yellow, <i>Phoebis sennae</i>
	Apricot, <i>Phoebis argante</i>
	Gonatryx, <i>Anteos maerula</i>
	Small White, <i>Eurema albula</i>
	Little Yellowie, <i>Eurema venusta</i>
	Small yellow, <i>Eurema leuce</i>
	Small Banded Yellow, <i>Eurema elathea</i>
Cabbage white, <i>Ascia monuste</i>	
Riodinidae	Brown and Cream, <i>Nymula Nymula calyce</i>
Lycaenidae	Common Blue, <i>Hemiargus hanno</i>
	Meadow blue, <i>Leptotes cassius</i>
	Dusty Blue Hairstreak, <i>Calycopis beon</i>
	Large Brilliant, <i>Oenomaus ortygnus</i>
	Black-Backed Blue, <i>Mithras hemon</i>



### 5.11.1.3 Field Studies

Field studies were conducted in terrestrial and aquatic habitats within the project area, at locations mentioned in Section 5.11.1.1 in order to authenticate the historical background data of species. The result of these studies displayed that with the exception of birds; comparatively few vertebrate species were observed, when compared to historical possible species.

Evidence of amphibians was limited to one chorus of *Leptodactylus validus* and one foam nest of *Engystomops pustulosus*. Reptiles actually observed during the site visits were limited to one Spectacled Caiman, *Caiman crocodilus* a few *Ameiva ameiva* and one *Gonatodes vittatus*. Residents also advised of the presence of Iguanas, *Iguana iguana*. There was conflicting opinion on the presence of a Matte, *Tupinambis teguixin*.

The only mammals observed were the Trinidad Squirrel, *Sciurus granatensis*. Residents advised of the occurrence of Black-eared Opossum, *Didelphis marsupialis* and workers at San Fernando Hill thought that there may be a few surviving Agouti, *Dasyprocta agouti*.

Very few butterflies were seen during the field visits. This is likely, in part, due to the timing of the field visits. The latter half of the wet season is generally not the best time for collecting butterflies and years with a comparatively wet dry-season are not as good for butterfly collection as years with a harsh dry season (Barcant (1970)). Those butterflies which were observed are listed in Table 5-20.

**Table 5-20 Butterflies Observed Within San Fernando and Environs, October 2009**

Family	Species*
Satyridae	<i>Euptychia</i> sp., Ringlet
Danaidae	<i>Danaus plexippus</i> , Monarch
Ithomiidae	<i>Mechanitis polymnia</i> , Sweetoil
Heliconidae	<i>Heliconius</i> sp. Postman
Heliconidae	<i>Calaenis iulia</i> , Flambeau
Heliconidae	<i>Dione juno</i> , Scarce Silver-spotted Flambeau
Nymphalidae	<i>Metamorpha stelenes</i> , Bamboo Page
Nymphalidae	<i>Anartia jatrophe</i> , Biscuit
Nymphalidae	<i>Anartia amathea</i> , Coolie
Nymphalidae	<i>Precis lavinia zonatis</i> , Donkey's Eye
Brassolidae	<i>Caligo teucer insulanus</i> , Cocoa Mort Bleu
Papilionidae	<i>Papilio homothoas</i> , Small King Page

Note: \* Names follow Barcant (1970) except for *Mechanitis polymnia*.

Aquatic Field Studies

Within the catchment areas surveyed a total of sixty-six (66) finfish and shrimp specimens were collected during the sampling period. Five of the thirteen locations had no fish presence. These were the Ciperu Upper, Ciperu Middle 1, Ciperu Middle 2, Guaracara Upper and Guaracara Middle locations. These specimens belonged to ten (10) species representing ten (10) different families. A list of all the species caught within the rivers surveyed is provided in Table 5-21.

The predominant species observed in upstream riverine locations (MU and VM) was the Guppy (*Poecilia reticulata*). These fish are tolerant of polluted, turbid waters with low levels of dissolved oxygen. There were also two main species collected in the middle course of the Vistabella River; Black Tilapia (*Oreochromis mossambicus*) and Mullet (*Mugil* sp.). Both these species are generally found in brackish to freshwater environments with “sluggish” slow moving waters. Their presence suggests that the station along the middle course of the Vistabella River can be subjected to tidal influences.

Within the lower courses of the rivers surveyed, Catfish (*Arius* sp.) appeared to be the most predominant species. However, this species is benthopelagic and, as such, their prevalence in the sample population may have been as a result of the gear type (fish pots) used for fishing and not a true reflection of the aquatic community structure.

**Table 5-21 Description of Fish Species Captured per Sample Station**

Family	Species	Common Name	GL	ML	MU	VL	VM	CL	GoL	GoM
Achiridae	<i>Achirus lineatus</i>	Lined Sole/ Flounder								X
Anablepidae	<i>Anableps anableps</i>	Four-eyed Fish								X
Ariidae	<i>Arius</i> sp.	Catfish	X	X		X		X		X
Centropomidae	<i>Centropomus undecimalis</i>	Brochet								X
Cichlidae	<i>Oreochromis mossambicus</i>	Tilapia					X			
Gerreidae	<i>Diapterus rhombeus</i>	Blinch	X	X						
Mugilidae	<i>Mugil</i> sp.	Mullet					X			
Penaeidae	<i>Xiphopenaeus kroyeri</i>	Honey Shrimp							X	
Poeciliidae	<i>Poecilia reticulata</i>	Guppy			X		X			
Sciaenidae	<i>Micropogon furnieri</i>	Racando	X						X	

Note: No samples were collected at Stations CU, CM1, CM2, GU and GM. As a result these locations are not cited in the table above.



### Bird Field Studies

Birds constituted the majority of vertebrate species observed during the field visits. Overall 84 species were observed, Table 5-22. The species observed were generally consistent with expectations for the different habitats with greatest numbers from the coastal habitats. Three species observed in Palmiste Park were unexpected, Rufous-breasted Hermit, *Glaucis hirsutus*, Little Hermit, *Phaethornis longuemareus*, and Cocoa Thrush, *Turdus fumigatus*. These species are usually associated with a forest environment, and while they are normally observed on the edges of forest they are seldom seen far from a forest environment.

The small patch of mangrove at the mouth of the Guaracara River housed several bird species characteristic of mangrove. These species included Common Black Hawk, *Buteogallus anthracinus*, Straight-billed Woodcreeper, *Xiphorhynchus picus*, Brown-crested Flycatcher, *Myiarchus tyrannulus*, and Bicoloured Conebill, *Conirostrum bicolor*. This mangrove also supported populations of Blue Crabs *Cardisoma guanhumi*, Hairy Crabs *Ucides cordatus* and Fiddler Crabs *Uca* spp. No mangrove Tree Crabs, *Aratus pisonii* were observed.



Table 5-22 Bird Species Observed Within San Fernando and Environs, October 2009

Species	Scrub and agriculture	San Fernando Hill	Palmiste Park	Usine St. Madeline	Bellair Mudflats	Guaracara Mangrove	San Fernando Wharf	Boatyard	Cipero River
Pelicanidae									
Brown Pelican, <i>Pelicanus occidentalis</i>					36	10	261	20	
Fregatidae									
Magnificent Frigatebird, <i>Fregata magnificens</i>					X				
Ardeidae									
Black-crowned Night-heron, <i>Nycticorax nycticorax</i>					X				
Striated Heron, <i>Butorides striatus</i>				X					
Cattle Egret, <i>Bubulcus ibis</i>	X		X	X					
Tricolored Heron, <i>Egretta tricolor</i>								X	
Snowy Egret, <i>Egretta thula</i>				X	X		X	X	X
Little Blue Heron, <i>Egretta caerulea</i>					X				
Cathartidae									
Turkey Vulture, <i>Cathartes aura</i>	X								
Black Vulture, <i>Coragyps atratus</i>	X	X	X	X		X			
Accipitridae									
Osprey, <i>Pandion haliaetus</i>		X			X	20		X	
Common Black-hawk, <i>Buteogallus anthracinus</i>						X			
Zone-tailed Hawk, <i>Buteo albonotatus</i>	X								
Rallidae									
Common Moorhen, <i>Gallinula chloropus</i>				X					
Purple Gallinule, <i>Porphyrio martinica</i>			X	X					



Table 5-22 Bird Species Observed Within San Fernando and Environs, October 2009 (continued)

Species	Scrub and agriculture	San Fernando Hill	Palmiste Park	Usine St. Madeline	Bellair Mudflats	Guaracara Mangrove	San Fernando Wharf	Boatyard	Cipero River
Charadriidae									
Southern Lapwing, <i>Vanellus chilensis</i>				X					
Black-bellied Plover, <i>Pluvialis squatarola</i>					X			X	
Semipalmated Plover, <i>Charadrius semipalmatus</i>					X	X		X	
Scolopacidae									
Whimbrel, <i>Numenius phaeopus</i>					X			X	
Lesser Yellowlegs, <i>Tringa flavipes</i>	X				X				X
Willet, <i>Catoptrophorus semipalmatus</i>					X				
Spotted Sandpiper, <i>Actitis macularia</i>	X					X		X	X
Ruddy Turnstone, <i>Arenaria interpres</i>					X			X	
Semipalmated Sandpiper, <i>Calidris pusilla</i>	X			X	100+	X		X	X
Western Sandpiper, <i>Calidris mauri</i>					200+	X		X	
Least Sandpiper, <i>Calidris minutilla</i>						X			
White-rumped Sandpiper, <i>Calidris fuscicollis</i>						X			
Pectoral Sandpiper, <i>Calidris melanotos</i>									X
Jacanicidae									
Wattled Jacana, <i>Jacana jacana</i>				X					
Laridae									
Laughing Gull, <i>Larus atricilla</i>					200	X	16	X	
Gull-billed Tern, <i>Sterna nilotica</i>							X		
Common Tern, <i>Sterna hirundo</i>					39	X	X		



Table 5-22 Bird Species Observed Within San Fernando and Environs, October 2009 (continued)

Species	Scrub and agriculture	San Fernando Hill	Palmiste Park	Usine St. Madeline	Bellair Mudflats	Guaracara Mangrove	San Fernando Wharf	Boatyard	Cipero River
Large-billed Tern, <i>Phaetusa simplex</i>					55		X	X	
Columbidae									
Ruddy Ground-dove, <i>Columbina talpacoti</i>	X	X	X	X		X		X	
Rock Dove, <i>Columba livia</i>	X	X							
Eared Dove, <i>Zenaida auriculata</i>	X	X		X					
Psittacidae									
Green-rumped Parrotlet, <i>Forpus passerinus</i>	X	X	X			X			
Cuculidae									
Smooth-billed Ani, <i>Crotophaga ani</i>	X								
Striped Cuckoo, <i>Tapera naevia</i>	X								
Strigidae									
Ferruginous Pygmy-owl, <i>Glaucidium brasilianum</i>			X			X			
Apodidae									
Short-tailed Swift, <i>Chaetura brachyuran</i>		X							
Trochilidae									
Rufous-breasted Hermit, <i>Glaucis hirsutus</i>			X						
Little Hermit, <i>Phaethornis longuemareus</i>			X						
Copper-rumped Hummingbird, <i>Amazilia tobaci</i>		X	X			X			
Alcedinidae									



Table 5-22 Bird Species Observed Within San Fernando and Environs, October 2009 (continued)

Species	Scrub and agriculture	San Fernando Hill	Palmiste Park	Usine St. Madeline	Bellair Mudflats	Guaracara Mangrove	San Fernando Wharf	Boatyard	Cipero River
Pygmy Kingfisher, <i>Chloroceryle aenea</i>						X			
Furnariidae									
Pale-breasted Spinetail, <i>Synallaxis albens</i>						X			
Yellow-chinned Spinetail, <i>Certhiaxis cinnamomea</i>				X					
Dendrocolaptidae									
Straight-billed Woodcreeper, <i>Xiphorhynchus picus</i>						X			
Thamnophilidae									
Barred Antshrike, <i>Thamnophilus doliatus</i>			X			X			
Tyrannidae									
Yellow-bellied Elaenia, <i>Elaenia flavogaster</i>	X	X		X					
Southern Beardless Tyrannulet, <i>Camptostoma obsoletum</i>	X		X						
Pied Water-tyrant, <i>Fluvicola pica</i>				X					X
White-headed Marsh-tyrant, <i>Arundinicola leucocephala</i>				X					
Great Kiskadee, <i>Pitangus sulphuratus</i>	X	X	X	X		X			
Boat-billed Flycatcher, <i>Megarynchus pitangua</i>		X							
Tropical Kingbird, <i>Tyrannus melancholicus</i>	X	X		X		X			





**Table 5-22 Bird Species Observed Within San Fernando and Environs, October 2009 (continued)**

Species	Scrub and agriculture	San Fernando Hill	Palmiste Park	Usine St. Madeline	Bellair Mudflats	Guaracara Mangrove	San Fernando Wharf	Boatyard	Cipero River
Fork-tailed Flycatcher, <i>Tyrannus savanna</i>	X								
Brown-crested Flycatcher, <i>Myiarchus tyrannulus</i>						X			
Vireonidae									
Rufous-browed Peppershrike, <i>Cyclarhis gujanensis</i>			X						
Red-eyed Vireo, <i>Vireo olivaceus</i>		X							
Hirundinidae									
White-winged Swallow, <i>Tachycineta albiventer</i>					X	X	X		
Grey-breasted Martin, <i>Progne chalybea</i>		X	X						
Southern Rough-winged Swallow, <i>Stelgidopteryx ruficollis</i>			X			X			
Barn Swallow, <i>Hirundo rustica</i>	X								
Troglodytidae									
House Wren, <i>Troglodytes aedon</i>	X	X	X					X	
Sylviidae									
Long-billed Gnat-wren, <i>Ramphocaelus melanurus</i>		X	X						
Turdidae									
Bare-eyed Robin, <i>Turdus nudigenis</i>	X	X	X	X		X			
Cocoa Thrush, <i>Turdus fumigatus</i>			X						



Table 5-22 Bird Species Observed Within San Fernando and Environs, October 2009 (continued)

Species	Scrub and agriculture	San Fernando Hill	Palmiste Park	Usine St. Madeline	Bellaire Mudflats	Guaracara Mangrove	San Fernando Wharf	Boatyard	Cipero River
Mimidae									
Tropical Mockingbird, <i>Mimus gilvus</i>		X	X	X		X			
Coerebidae									
A Bananaquit, <i>Coereba flaveola</i>		X	X			X			
Thraupidae									
White-lined Tanager, <i>Tachyphonus rufus</i>		X	X			X			
Blue-grey Tanager, <i>Thraupis episcopus</i>	X	X	X	X		X			X
Bicolored Conebill, <i>Conirostrum bicolor</i>						X			
Emberizidae									
Saffron Finch, <i>Sicalis flaveola</i>		X				X		X	
Blue-black Grassquit, <i>Volatinia jacarina</i>		X		X		X			
Cardinalidae									
Greyish Saltator, <i>Saltator coeruleus</i>	X	X		X					
Parulidae									
Yellow Warbler, <i>Dendroica petechia</i>	X	X	X	X		X			
Northern Waterthrush, <i>Seiurus noveboracensis</i>						X			
Icteridae									
Crested Oropendola, <i>Psarocolius decumanus</i>	X		X						
Yellow Oriole, <i>Icterus nigrogularis</i>	X	X	X			X			



**Table 5-22 Bird Species Observed Within San Fernando and Environs, October 2009 (continued)**

Species	Scrub and agriculture	San Fernando Hill	Palmiste Park	Usine St. Madeline	Bellair Mudflats	Guaracara Mangrove	San Fernando Wharf	Boatyard	Cipero River
Shiny Cowbird, <i>Molothrus bonariensis</i>	X								
Carib Grackle, <i>Quiscalus lugubris</i>			X			X			
Yellow-hooded Blackbird, <i>Chrysomus icterocephalus</i>			X	X					
Euphonidae									
Trinidad Euphonia, <i>Euphonia trinitatis</i>		X							



#### 5.11.1.4 Species of Local or Regional Significance

Species of local significance include those of economic importance, those that are under a level of threat and receiving some form of protection under the law (or should be) and those which are covered by international treaties.

#### 5.11.1.5 Species of Commercial Importance

Among the finfish captured Tilapia, Mullet, Catfish, Racando (*Micropogon furnieri*), Blinch (*Diapterus rhombeus*) and Brochet (*Centropomus undecimalis*) are game fish and are usually caught on light tackle. Racando, Brochet, Tilapia and Mullet were the most commercially important species of fish noted. Honey shrimp (*Xiphopenaeus kroyeri*) was also caught within the study area. This species is listed as a popular marine species in fisheries of Trinidad and Tobago (United Nations Food and Agriculture Organization, 2010). There is some legal hunting of Iguanas and Manicou wherever they occur. There was also evidence of collection of Blue Crabs *Cardisoma guanhumi*, and Hairy Crabs *Ucides cordatus* in the mangrove around Guaracara River.

#### 5.11.1.6 Protected Species

The Conservation of Wildlife Act identifies three categories of protected species - *Endangered*, *Vulnerable* and *Rare*. No *Endangered* species were encountered during the surveys. The Scarlet Ibis, Yellow-crowned Parrot and Silky Anteater have been listed as *Vulnerable* under Schedule 4 part B. The Yellow-crowned Parrot *Amazona ocreocephala* is also listed as *Vulnerable* and is likely to be found in the study area as it is usually associated with urban areas of Trinidad. Of the species listed as *Rare* in the Act, only one species Red-capped Cardinal is expected to be present although Rufous-necked Wood-Rail may occur.

None of the species observed are listed as Environmentally Sensitive Species, under the Environmental Management Act of 2000.

None of the species observed or expected have been listed in the 2003 International Union for Conservation of Nature (IUCN) Red List of Threatened Species.

Bird species deemed to be vulnerable in Trinidad according to (Temple, 2002) include Yellow Crowned Parrot, Boat-billed Heron, Rufous Crab-Hawk, Red-capped Cardinal, Pearl Kite, Mangrove Cuckoo, Anhinga, Zone-tailed Hawk and several seedeaters (not saffron finch). The Rufous Crab Hawk is a rare resident, highly dependent on mangrove woodland. It has not however been listed as protected by the Conservation of Wildlife Act 1999. Boat-billed Heron is another rare resident which depends on secluded mangrove for breeding and has been observed breeding further south in the Roussillac Swamp.

The Peregrine Falcon is listed in Appendix 1 of the Convention on International Trade in Endangered Species of Wild Flora and Fauna (CITES). Several of the species expected and observed are listed in Appendix II of the convention including; Scarlet Ibis, Caribbean Flamingo, all birds of prey, parrots and hummingbirds, Spectacled Caiman, large lizards and snakes like the Iguana, Matte, Boa Constrictor and Anaconda. These species are listed under Appendix II of CITES because they can be confused with species genuinely threatened by international trade.



With respect to the Specially Protected Areas and Wildlife (SPAW) Protocol, the Peregrine Falcon is listed in Annex II which requires signatories to prohibit the disturbance of such species, particularly during periods of biological stress. A number of other species recommended for inclusion include the Magnificent Frigate bird, Osprey, Merlin, Scarlet Ibis and several of the herons likely to inhabit the mangrove and coastal zone.

In comparing the protected species discussed above to the field studies conducted:

- The Zone-tailed Hawk was observed, which is listed as a vulnerable species (Temple, 2002).
- Spectacled Caiman, Iguana, Matte, birds of prey including Osprey, Common Black-Hawk, and Zone-tailed Hawk, and hummingbirds including Copper-Rumped Hummingbird were observed, which are listed under CITES as predicted endangered species in the future, or look-alike species to endangered species.
- The Magnificent Frigate Bird and Osprey were observed, which are listed as recommended for inclusion under SPAW protocol to prohibit disturbance.

The National Environmental Policy requires developmental projects to result in no net loss of wetland (including mangrove). The revised policy (Environmental Management Authority, 2009) includes mangrove with 'keystone species'. The most significant freshwater wetland identified in this report is the ponds at Usine St. Madeline which are well outside of the impact zone. The trunk lines running from the Guaracara River south to the Marabella and Vistabella Rivers may impact the mangrove woodland at the mouths of these rivers. If so this mangrove must be restored to be in compliance with the National Environmental Policy.

## 5.12 Noise Quality

The TOR for the CEC application also required the monitoring of sound pressure levels and vibrations within the San Fernando Wastewater Catchment, in order to assess the baseline conditions of the environment. The environmental noise measured in the project area would also be used according to the TOR to assess the impact of the vibration and sound on the flora and fauna in the area.

Environmental noise is defined as noise emitted from anthropogenic activities such as, transport and other routine human activities which emit unwanted sound. The NPCR of Trinidad and Tobago refers to noise as sound pressure level which can be measured on an instantaneous scale and expressed as decibels (dB). Sound pressure level can also be "A-weighted" which gives a better indication of noise that would be sensitive to the human ear, it is expressed as dBA.

Noise monitoring stations were located at five sensitive receptor sites within the project area; two residential areas and, adjacent to a lift station, a health centre, and an existing wastewater treatment plant (Figure 5-35). The sound level was monitored for a 24 hour period at each site using a Quest® 2900 Sound Level Meter and a Quest® Outdoor Measurement System Kit. The equivalent ( $L_{eq}$ ) and peak ( $L_{peak}$ ) sound pressure levels were recorded at 30 minute intervals over the 24 hour period; the results are attached in **Appendix D.6**. Table 5-23 summarizes the  $L_{eq}$  at these five stations.



Figure 5-35 Air and Noise Monitoring Stations in San Fernando Wastewater Catchment Area



**Table 5-23 Sound Level Monitoring Results**

Interval	Marabella Residential Area (dBA)	La Romain Residential Area (dBA)	Harmony Hall Lift Station (dBA)	Pleasantville Health Centre (dBA)	San Fernando WWTP (dBA)
8 am	55	66	54	63	65
	55	66	54	69	64
9 am	55	71	58	61	64
	56	68	64	62	59
10 am	55	65	69	61	62
	55	67	62	61	61
11 am	54	65	65	62	66
	55	66	67	62	66
12 am	57	67	63	62	65
	54	65	66	62	64
1 pm	55	66	75	62	65
	54	64	61	61	64
2 pm	54	65	62	62	64
	54	68	55	61	64
3 pm	55	65	65	60	64
	55	66	57	62	63
4 pm	56	66	57	61	63
	57	83	55	62	63
5 pm	56	72	56	64	63
	55	67	54	63	63
6 pm	58	67	56	68	63
	56	65	55	63	63
7 pm	55	65	55	63	62
	53	65	55	62	63
8 pm	56	67	53	62	63
	53	67	55	62	62
9 pm	53	63	57	62	62
	52	64	59	60	63
10 pm	54	62	52	60	63
	54	62	51	61	63
11 pm	53	60	50	61	63
	54	59	48	64	62
12 am	54	60	49	57	62
	54	61	52	55	62
1 am	54	56	50	56	63
	53	56	48	54	63
2 am	55	55	52	55	63
	57	54	51	53	63



**Table 5-23 Sound Level Monitoring Results (continued)**

Interval	Marabella Residential Area (dBA)	La Romain Residential Area (dBA)	Harmony Hall Lift Station (dBA)	Pleasantville Health Centre (dBA)	San Fernando WWTP (dBA)
3 am	55	51	54	53	63
	54	51	55	60	62
4 am	55	54	57	55	62
	54	58	73	55	63
5 am	54	57	70	54	64
	55	62	71	55	64
6 am	56	62	68	57	64
	56	65	71	59	65
7 am	58	65	66	59	64
	56	65	57	60	64

The average  $L_{eq}$  was highest in La Romain Residential area at 67 dBA in the day period as defined in the First Schedule of the NPCR. The San Fernando WWTP however had the highest  $L_{eq}$ , recorded at 63 dBA in the night period. The average readings are presented in Table 5-24. As illustrated, the  $L_{peak}$  attained a level of 123 dB at the Pleasantville Health Centre. This site would fall under Zone III or General Area according to the NPCR where the  $L_{peak}$  should not exceed 120 dB during the day-time; this was the only survey station that exceeded this limit. The  $L_{peak}$  limit for the night-time is 115 dB; the environmental noise recorded at all five receptor stations was below this limit.

The San Fernando WWTP is considered an industrial site according to the EMA and the TCPD. As a result the limits defined for Zone I or Industrial Areas in the First Schedule of the NPCR would apply. The  $L_{eq}$  should not exceed 75 dBA at anytime; the environmental noise at the San Fernando WWTP stayed within this limit. The  $L_{peak}$  according to the regulations must not surpass 130 dB and based on the sampling at the plant this limit was not exceeded.

**Table 5-24 Average  $L_{eq}$  and  $L_{peak}$  Measurements for Noise Sampling**

Sound Pressure Level	Period	Marabella Residential Area (dB)	La Romain Residential Area (dB)	Harmony Hall Lift Station (dB)	Pleasantville Health Centre (dB)	San Fernando WWTP (dB)
$L_{eq}$	8 am to 8 pm	55	67	60	62	63
$L_{peak}$	8 am to 8 pm	103	115	113	123	119
$L_{eq}$	8 pm to 8 am	55	60	57	58	63
$L_{peak}$	8 pm to 8 am	102	115	113	111	117





The instantaneous increase in sound pressure levels at and around the sample sites may be attributed to:

- Sound from vehicles passing along roadways.
- Recreational and social activities including bars.
- Construction activities.

### 5.13 Ambient Air Quality

Air pollution is described as the emission of any substance categorised as an air pollutant according to the draft APR of Trinidad and Tobago. For this project only the particulate matter was recorded, this included particles with diameters measuring 10 micrometres or less (PM<sub>10</sub>), particles with diameters less than or equal to 2.5 micrometres (PM<sub>2.5</sub>) and the total suspended particles (TSP) which are less than 100 micrometres in diameter. The TOR required that monitoring of air quality be done in the area around the proposed WWTP site.

The survey equipment was set up at the same sites as the noise monitoring stations. The Airmetrics Minivol® was used to measure the TSP and PM<sub>2.5</sub> and the TSI Dust Trak® was used to measure PM<sub>10</sub> concentrations. The Minivol was set to collect samples over a 24 hour period; the air streamed through the equipment and a filter collected the particles with diameters less than 100 µm (micrometers) for TSP and less than 2.5 µm (micrometres) for PM<sub>2.5</sub>. These were then weighed by ROSE Environmental Limited to determine the amount of particles in the atmosphere. Table 5-25 represents the results of this sampling event in comparison to the maximum permissible levels defined in the Second Schedule of the draft APR.

**Table 5-25 TSP and PM<sub>2.5</sub> Air Quality Results in San Fernando Wastewater Catchment**

Site	Weight of TSP (µg/m <sup>3</sup> )	Draft APR TSP Limit (µg/m <sup>3</sup> )	Weight of PM <sub>2.5</sub> (µg/m <sup>3</sup> )	Draft APR PM <sub>2.5</sub> Limit (µg/m <sup>3</sup> )
Marabella Residential Area	89.7	150	64.2	65
La Romain Residential Area	55		19.4	
Harmony Hall Lift Station	36		48.6	
Pleasantville Health Centre	54.5		13.1	
San Fernando WWTP	66.4		22.1	

PM<sub>10</sub> concentrations were measured at one minute intervals over a 24 hour period. The data report sheets are appended in **Appendix D.7**. The average PM<sub>10</sub> values for each sample site are as follows:

- Marabella Residential Area – 168 µg/m<sup>3</sup>
- La Romain Residential Area – 35 µg/m<sup>3</sup>
- Harmony Hall Lift Station - 33 µg/m<sup>3</sup>
- Pleasantville Health Centre - 25 µg/m<sup>3</sup>
- San Fernando WWTP - 56 µg/m<sup>3</sup>



The maximum permissible limit for  $PM_{10}$  is  $75 \mu\text{g}/\text{m}^3$  for a 24 hour period according to the Second Schedule of the draft APR. All the sample sites were within these limits, except the  $PM_{2.5}$  level almost surpassed the regulation.

Analysis of the data proved that the Marabella Residential Area has a high level of pollutants in the atmosphere and this can result in detrimental effects to human health. Research done at the United States of America Environmental Protection Agency (USEPA) concludes that humans exposed to high levels of  $PM_{10}$  and  $PM_{2.5}$  can suffer from breathing and respiratory illnesses, damage to lung tissue, cancer and premature death (U.S. Environmental Protection Agency). The high concentration of particles in the air is presumed to be a product of petroleum production in the nearby Petrotrin refinery.

The  $PM_{2.5}$  values at the San Fernando WWTP even though within the standards are still relatively high. This may be attributed to the fact that a large portion of the WWTP is unpaved and drought conditions were experienced at the time of sampling. These factors would have exacerbated the dust and increased air particles. The values recorded for TSP and  $PM_{2.5}$  within the La Romain Residential Area may have been affected by nearby roadwork. Investigation of the baseline conditions at this locality showed that it is a very active area with a lot of businesses making it a common and populated area.

Overall, some of the causes of elevated air particulate concentrations in the San Fernando Wastewater Catchment Area likely include:

- Vehicular emission.
- Construction activities.
- Refinery operations.
- Bush fires, which were widespread around the sampling time.



## 6. Social Environmental Conditions

### 6.1 Introduction

The social or human environment is defined as any physical space in which humans occupy whether for living, working, recreation or business purposes. The baseline assessment of the social environment will be discussed in this report under the following headings:

- History
- Land Use
- Archaeology
- Employment
- Recreation
- Public Institutions
- Population Demographics
- Socio-Economic
- Traffic

These themes will be discussed and used in conjunction with the findings of the biophysical survey to determine the potential impact the San Fernando Wastewater Project will have on the biological and human environment.

### 6.2 Study Area

The size of the study area is approximately 42 km<sup>2</sup> and this was divided into several subcatchments (Figure 3-24) by AECOM based on natural topography, drainage and physical boundaries. The demarcation of subcatchments is mainly for construction purposes where the work can be phased to ensure maximum cost-to-construction benefits.

The San Fernando Wastewater Catchment Area illustrated in (Figure 3-1) is divided into three administrative areas; San Fernando City Corporation, Penal/Debe Regional Corporation and Princes Town Regional Corporation. These administrative areas are broken up into communities and then subdivided into enumeration districts (ED) by the Central Statistical Office (CSO) of the Government of Trinidad and Tobago. An enumeration district is described as “a geographical area comprising approximately one hundred and fifty to two hundred (150 to 200) households” (Central Statistical Office, 2002). The classification of each enumeration district within the administrative areas is described in Section 6.7, while specific EDs are given a description based on the community it is sited in. All the EDs of the San Fernando City Corporation are within the project boundaries of the San Fernando Wastewater Catchment area. However, not all of the EDs within the Penal/Debe and Princes Town Regional Corporations lie within the study area.

The current population of the San Fernando Area is estimated at 90,200 based on housing counts conducted by AECOM. The total population recorded in the 2000 Census was 89,200 (Central Statistical Office, 2002). The San Fernando WWTP and Collection System have to be designed until the year 2035; the population is projected to increase to 111,600 by this time.



### 6.3 Methodology

The TOR of the CEC application outlines specific factors that must be included in the social impact assessment (SIA) of this project. Broadly, the objectives are to: describe the human and socio-economic environment of the San Fernando Wastewater Catchment and to assess the potential impacts of construction, operation and decommissioning of the facility and associated infrastructure on the human and socio-economic environment.

The specific purpose of this part of the study as stated in the TOR is to:

- Describe socio-demographic characteristics of the population including; population size and socio-economic indicators.

A social survey was conducted by sub-consultant Market Facts and Opinions (2000) Limited (MFO) specifically targeting residents in areas that would be most affected by the San Fernando Wastewater Project as discussed in Section 6.13. Investigations into the historical and present-day characteristics of the human environment were done by AECOM from inception of the project until the completion of this report.

The Census statistics were also used for the social study. Interpretation of the defined boundaries of the CSO administrative areas were compared to that of the subcatchments of the proposed wastewater collection system design. Table 6-1 demonstrates the project subcatchments contained within each municipality in the project area. **Appendix E.1** contains a list of the communities for each municipality and subcatchment pertinent to the San Fernando Wastewater Project.

**Table 6-1 Subcatchments within Administrative Areas**

Administrative Area/Municipality	Subcatchment
San Fernando City Corporation	San Fernando South
	Green Acres
	Bel Air-Gulf View
	Vistabella
	Marabella
	Tarouba-Cocoyea
	Cocoyea South
	Pleasantville-Corinth
Penal/Debe Regional Corporation	La Romain South
	La Romain North
	La Romain Central
	Palmiste South

**Table 6-1 Subcatchments within Administrative Areas (continued)**

Administrative Area/Municipality	Subcatchment
Penal/Debe Regional Corporation	Picton
	Duncan Village
	Union Hall
Princes Town Regional Corporation	Retrench-Golconda
	Ste. Madeline

Secondary data was obtained from CSO and other external sources to support the findings of MFO and AECOM's study to further accomplish the objectives of the assessment.

## 6.4 Historical Development of Study Area

The history of the San Fernando Wastewater Catchment is important in explaining the existing infrastructure and services offered to the residents and businesses of the area. The area was named 'Anaparima' by the first settlers of the town; the native Amerindians. This term translated means single hill and was designated after what is now the San Fernando Hill. In the 1700s San Fernando was a fishing village and was only developed by the Spanish Governor in 1792.

In the 1800s, agriculture was the main industry in San Fernando where sugar cane, cotton and coffee were cultivated (Trinidad Guardian, 1998). The slaves, indentured labourers and Europeans settled in the area and as a result formed an ethnically diverse population. The first railway in Trinidad was constructed in San Fernando by a Scottish planter to transport produce from his sugar plantation to the wharf at San Fernando, named Kings Wharf (Ottley, 1971). The line was known as the Ciperio Tramway and ran along the western coast of San Fernando. The Ciperio Tramway was eventually absorbed by the Trinidad Government Railway (TGR) System and is now the proposed route of the Gulf Sewer Trunk expected to run from Guaracara River southward to the San Fernando WWTP.

The twentieth century brought the oil industry to the San Fernando Area, despite the first oil wells being drilled within the project area in 1866. These wells were not productive and oil exploration moved further south of Trinidad. Consequently San Fernando became the transport hub and expanded as companies servicing the oil industry set up in the area.

The villagers of San Fernando were of the opinion at this time that the Colonial Government abandoned the town since electricity was only installed in 1923, 28 years after Port-of-Spain (The Energy Chamber of T&T). The existing wastewater collection, treatment and disposal system was built in the 1960s and is owned and operated by WASA. The system was never upgraded since and this project seeks to accomplish this.



## 6.5 Land Use

The land use of the study area is described in Section 5.9.1 in terms of the biological environment. The land use will be discussed in this section according to human activity, categorised as follows:

- Residential
- Agriculture
- Light Industry
- Commercial

The residential land use includes all space where buildings are erected for persons to live; comprising vacant, closed, private and non-private dwellings as defined in the 2000 Census (**Appendix E.2**). Agriculture land spaces are all areas where land is cultivated with any crop or where animals are reared both on a small and large scale. Light industry is where the property is used for manufacturing of goods that are consumer-oriented and raw materials used are lightly processed; examples include clothing manufacture and drilling companies. Commercial land spaces are all the areas occupied by buildings designated for offices, shopping centres and restaurants.

The subcatchments within the San Fernando Wastewater Catchment were subdivided according to the type of activity that predominantly occurs in the area. Figure 6-1 depicts the land use per subcatchment and the main human activity within the area. In some cases the area was classified based on the activity the community is popular for. An example is the Bel Air-Gulf View subcatchment which is well known for Gulf City Mall and other commercial activities taking place within the vicinity. A more detailed land use map is presented in Section 5 as Figure 5-26.

Based on this land classification, the San Fernando Wastewater Catchment area is occupied predominantly by residential communities that have been developed both by private entities and the government sector. The proposed San Fernando Wastewater Collection System will service all the buildings within the wastewater catchment including future developments. Table 6-2 presents a list, prepared by AECOM of these new and proposed residential developments that would be serviced. In the case of sites where sewer design is incorporated, the San Fernando Wastewater Collection System design would make provisions for integrating this in the sewer design.

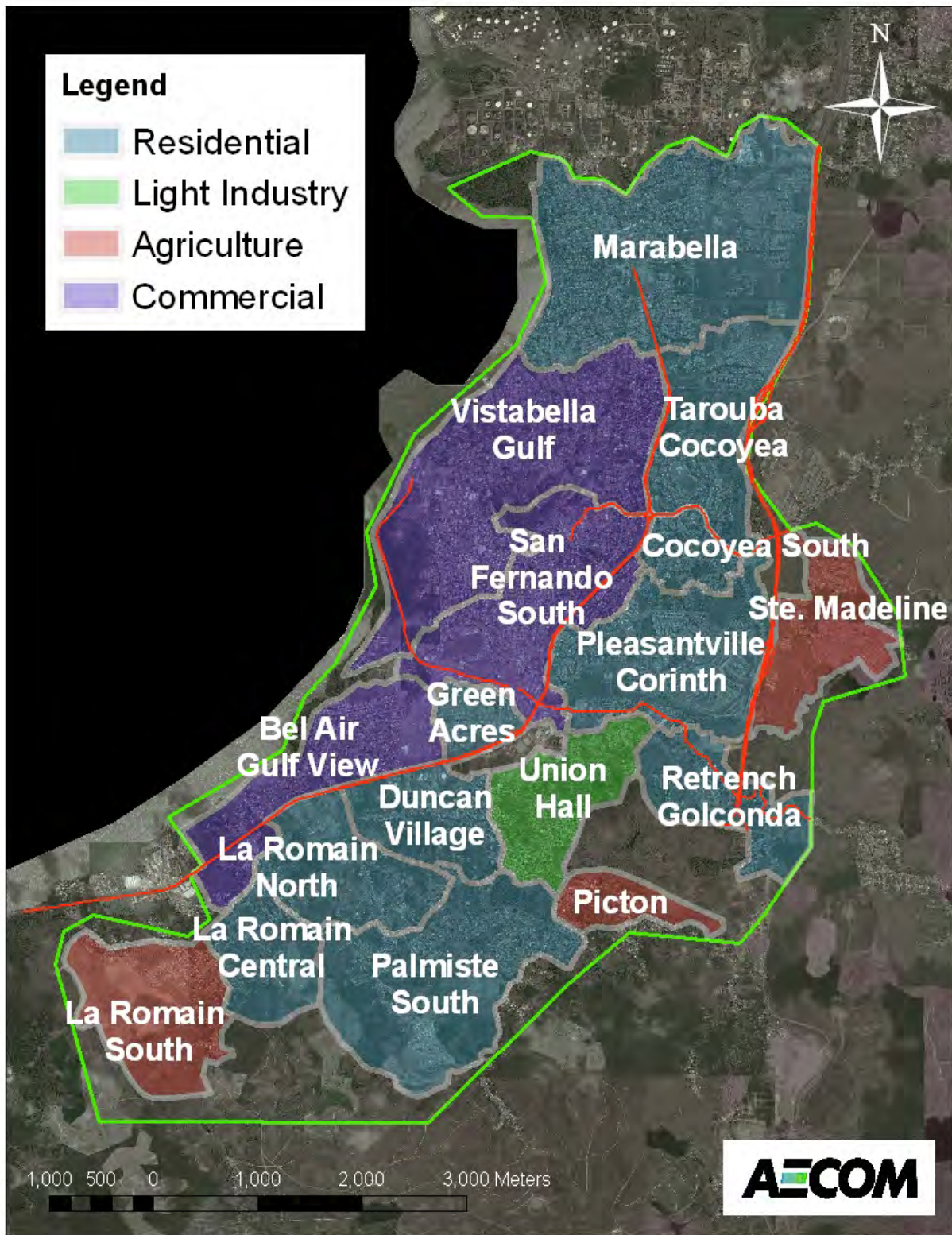


Figure 6-1 Land Use in San Fernando Wastewater Catchment based on Human Activity

**Table 6-2 New and Proposed Housing Developments in the San Fernando Wastewater Catchment**

Name of Development	No. of Lots	Construction Status
Boyack Development	42	Presently under construction
Corinth Housing Development	283	Construction nearly complete
Golconda Residential Development	270	Presently under construction
Hermitage Development	340	Presently under construction
Hosein Development	8	Presently under construction
La Fortune Housing Development	22	Presently under construction
La Romain Residential Development	915	Presently under construction
Lunarstar Development	21	No construction underway
Palmiste Development Phase I	144	Presently under construction
Rahaman's Development Phase III	18	No construction underway
Retrench (Hill Crest) Housing Development (Housing Development Corporation)	360	Construction nearly complete
Retrench Development	10	No construction underway
Rostam and Tahiroon Doman Development	7	No construction underway
St. Joseph Gardens	162	No construction underway
Tarouba South Phase IV	141	Presently under construction
Tarouba South Phase V	51	Presently under construction
UDECOTT Garden Apartments	unknown	No construction underway
Z.R. Meah John Development	unknown	No construction underway





## 6.6 Archaeology Sites

There are over 300 archaeological sites in Trinidad designated by the Archaeological Committee of Trinidad and Tobago. This society has now been absorbed by the National Trust under the Ministry of Community Development, Culture and Gender Affairs. The policy of the organisation is to conceal the exact location of the sites for preservation purposes. The Committee classify the sites according to the level of protection stipulated; this classification is illustrated in Table 6-3. The development plans for the project, in this case the sewer layout, must be examined by the appropriate body in order to ensure conservation of the archaeological sites.

In the first public consultation discussed in Section 7, a member of the Archaeological Committee of Trinidad and Tobago was present to observe the proposed plans for the wastewater catchment area. Concurrent to this, discussions with the past chairman of the Committee distinguished some of the archaeological sites within the study area. The sites identified by the Archaeology personnel are portrayed in Figure 6-2. All of these spots are within the San Fernando City area and presumably enfold indicators of Amerindian culture and the colonial history of the City. The impact of the San Fernando Wastewater Project to these sites will be discussed in Section 8.

**Table 6-3 Classification of Archaeological Sites**

Site Class	Definition	Notes
Class A	Protected Site. Should remain undisturbed	No Class A sites are known to exist within project area.
Class B	Important Site. Demolition can start only after an excavation has been done to retrieve any archaeological remains.	<ul style="list-style-type: none"><li>- Harris Promenade Site</li><li>- Carib Street Site</li><li>- Golconda (Teak Plantation) Site</li></ul>
Class C	On commencement of construction someone must be employed to collect samples of earth from excavated / disturbed areas or that which will be occupied by a permanent works.	<ul style="list-style-type: none"><li>- Tarouba Sites</li><li>- Spring Vale Site</li><li>- Golconda 2 Site</li><li>- Gulf City Mall Site</li><li>- Victoria Village Site*</li></ul>
Class D	Possible Site. Anecdotal Evidence. Location no longer known due to loss of records etc.	<ul style="list-style-type: none"><li>- San Fernando Hospital ( west side)</li><li>- Ciperio River Mouth</li><li>- Mount Moriah Road</li></ul>

Note: \*Victoria Village Site may be in close proximity to Ciperio Trunk Main



Figure 6-2 Archaeological Sites in San Fernando Wastewater Catchment



## 6.7 Employment

Employment in the San Fernando Wastewater Project Area is generally available in all sectors but is most prevalent in the service division. The main industry within the study area is petroleum; Petrotrin Oil Refinery and many other oil drilling and exploration companies are established in the area. The exact percentage of San Fernando residents employed in this sector is uncertain.

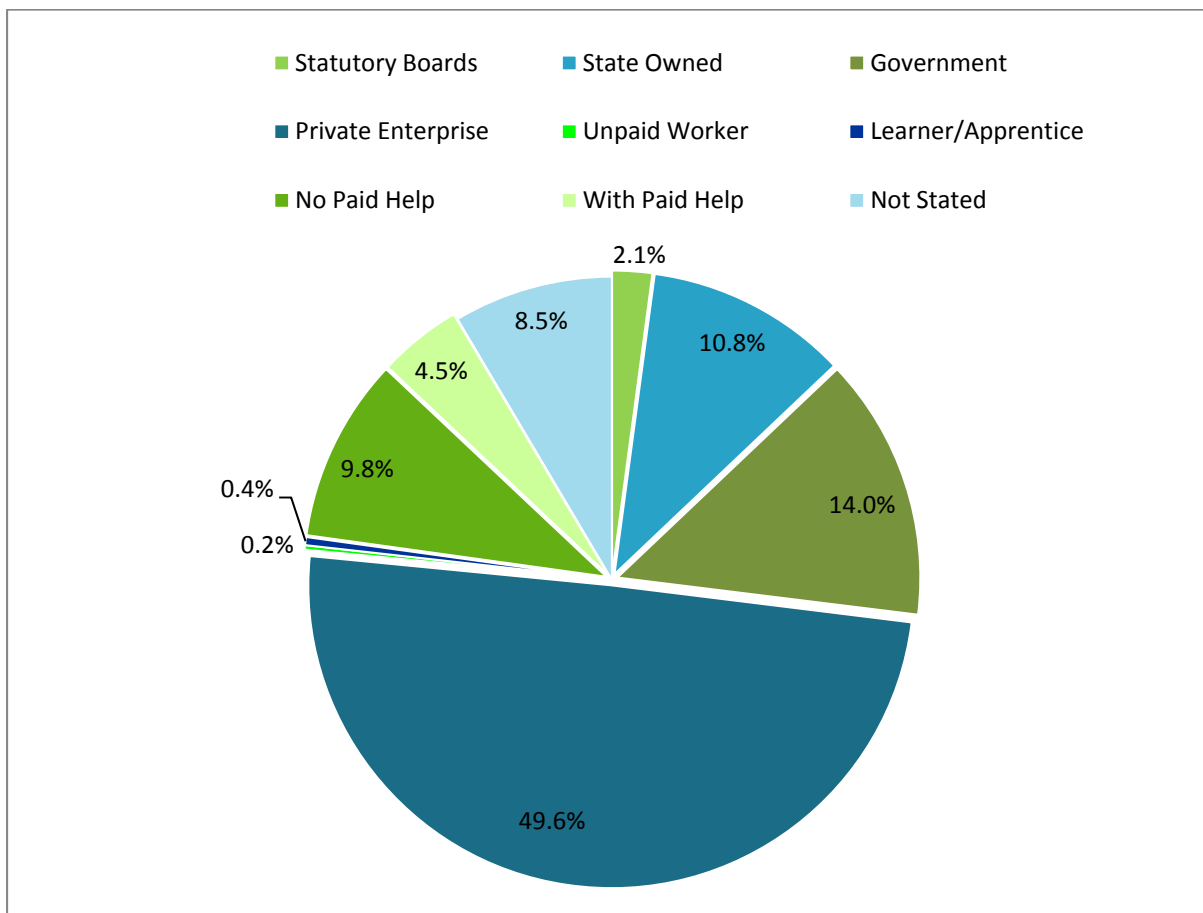
The CSO 2000 Census investigated the number of businesses existing in each administrative district and is provided in Table 6-4.

**Table 6-4 Businesses in San Fernando Wastewater Catchment (Central Statistical Office, 2002)**

Administrative Area	Enumeration District/Community Description	Number of Business Places
San Fernando City Corporation		3,102
Penal/Debe Regional Corporation	La Romain	216
	Duncan Village	204
	Golconda	35
	Rambert Village	29
	Palmiste	6
	Canaan Village/Palmiste	15
	Esperance Village	17
	Picton	35
	Hermitage Village	62
	Phillipine	30
Princes Town Regional Corporation	Diamond	30
	Golconda	18
	Corinth	45
	Ste. Madeline	48
<b>TOTAL</b>		<b>3,892</b>



In 2000, there were 3892 businesses recorded in the San Fernando Wastewater Catchment. Extensive commercial expansion has occurred in the study area between 2000 and 2010 specifically in the Duncan Village, Gulf View, La Romain, Vistabella and Marabella subcatchments. This has therefore provided ample job opportunities in the area. The 2000 Census also documented the worker status of the residents in the San Fernando City Corporation as depicted in Figure 6-3.



**Figure 6-3 Status of Employment in San Fernando City Corporation (Central Statistical Office, 2002)**

The majority of the San Fernando City Population which comprises the subcatchments listed in Table 6-1 is employed in private enterprises. The 2000 Census also subdivided the employment records into groups of general occupations and industry. The ratio of the population in each group is presented in Figure 6-4 and Figure 6-5. Additional updated statistics for the project area are reviewed in Section 6.13.

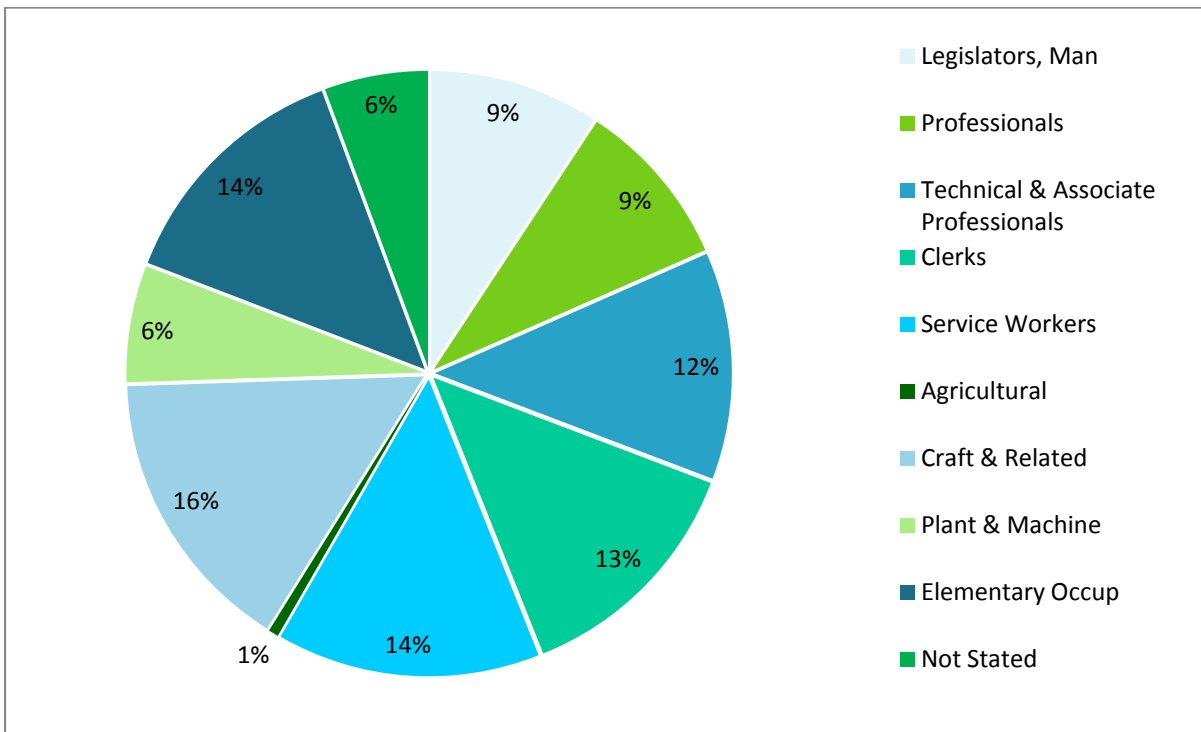


Figure 6-4 General Occupational Groups (Central Statistical Office, 2002)

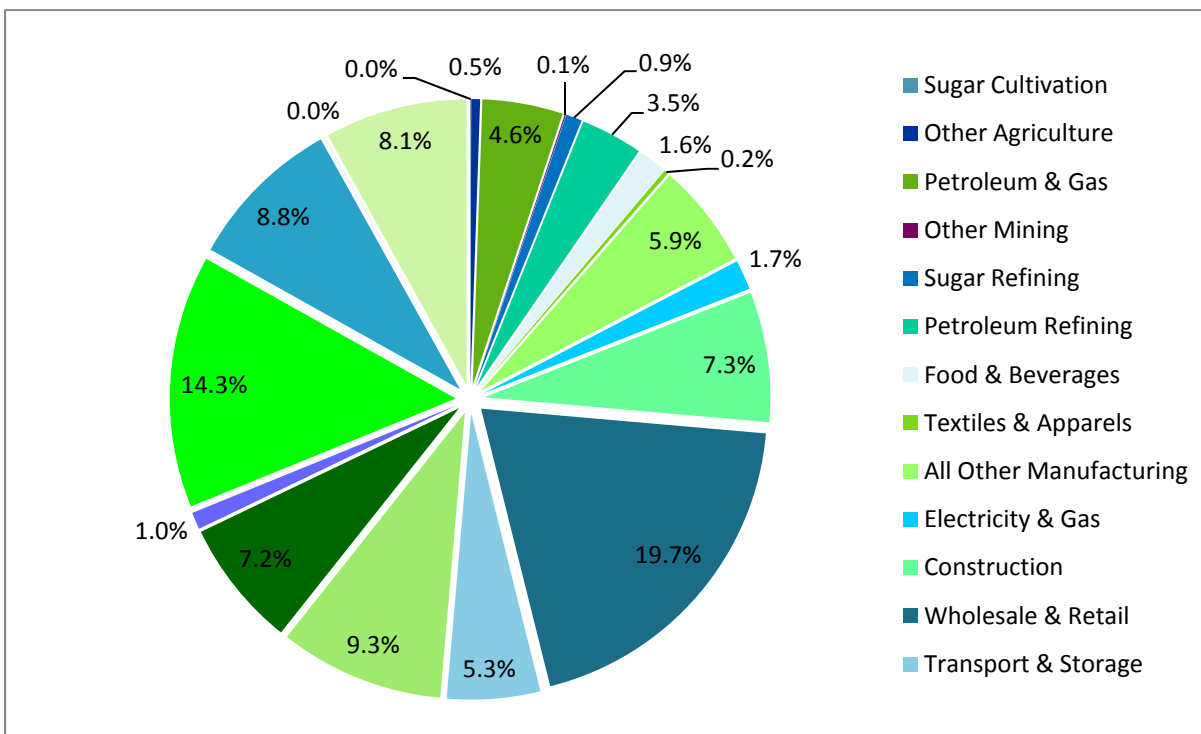


Figure 6-5 Residents Employed within Industry Sector (Central Statistical Office, 2002)



## 6.8 Recreational Activities

Recreational activities for the purpose of this study were defined as any hobby that the residents enjoyed for leisure or play. This included: parks, football grounds and clubs. Figure 6-6 illustrates the recreational facilities in the study area. The San Fernando Wastewater Collection System is not expected to affect any of these structures. Further information on recreational activities obtained through the social survey is discussed in Section 6.13.

## 6.9 Public Buildings and Institutions

The San Fernando Wastewater Project Area has a significant number of public buildings and institutions due to the history of the city and the expansive development that has occurred in recent times. Facilities of the protective services in Trinidad and Tobago and health centres can be considered public institutions; however, these will be discussed in further detail in Section 6.12.1 and 6.12.4. In this segment of the report, the following services will be discussed:

- Schools
- Community Centres
- Courts
- Libraries

### 6.9.1 Schools

There are a considerable number of schools in the San Fernando Wastewater Project area. They range from primary and secondary schools funded by the Trinidad and Tobago Government to those funded by church bodies and other private entities. There are also many tertiary institutions instructing on different subjects and trades. A list of all the primary, secondary and tertiary establishments in the San Fernando Wastewater Catchment is appended in **Appendix E.3**. These schools accommodate students within the project area and other communities outside of the San Fernando Wastewater Catchment boundaries. The student populations were used to give an estimate of the design flows for schools in the area.

### 6.9.2 Community Centres

The Ministry of Community Development, Culture and Gender Affairs has established two community centres within the project boundaries, these are the Vistabella Regional Complex and Ste. Madeline Regional Complex. Apart from these, there are also community centres that were established by the respective community council and leaders, examples of these are:

- Pleasantville Community Centre
- Cocoyea Community Centre
- Mon Repos Community Centre

The purpose of these centres is broadly to facilitate the members of the particular communities. The trend is that any person or organisation can rent the centre at a cost. Conversely, there are normally events and activities undertaken by the Ministry of Community Development, Culture and Gender Affairs and Corporation hosted at the buildings. These include; trade classes, homework supervision and other activities initiated by the relevant agency. These buildings would be serviced in the proposed San Fernando Wastewater Collection System Design.



### 6.9.3 Courts

The San Fernando area only has one supreme and magistrate court which services the population of the Wastewater Catchment. The San Fernando Supreme Court and the San Fernando Magistrate Court are both located between Knox and Harris Street on Harris Promenade. The law of Trinidad and Tobago requires that all criminal matters occurring in a certain area must be heard in the judicial court closest to the site in which it occurred. Therefore only offenses that have taken place within or around San Fernando will be tried in this courtroom.

### 6.9.4 Libraries

A library is considered a public building since it is available for use by all members of the public. There are two libraries that would service the San Fernando Wastewater population; Carnegie Free Library located on Harris Promenade and Debe Public Library. The Debe Public Library is not located within the San Fernando Wastewater Project boundaries, but would be accessed by residents living within the catchment area.



Figure 6-6 Recreational Places in San Fernando Wastewater Catchment





## 6.10 Population Demographics

Population demographics are usually described as the classification of statistics of a populace based on certain characteristics. The demographics are discussed in this report based on the categories of age, religion and ethnicity. The data is based on the Census 2000 data, which encompassed all communities within the San Fernando Wastewater Project area.

The 2000 Census, as described in Section 6.2 was conducted for the whole of Trinidad and Tobago. Each municipality was divided into communities and then these were further separated into EDs based on the classification described in Section 6.2. The 2000 Census data used for this project was taken per community that fell within the catchment boundaries.

### 6.10.1 General

The 2000 Census Data for the project area documented a total population count of 89,199 for the San Fernando Wastewater Catchment. Table 6-5 lists the population count and the breakdown by municipality for the project area; this includes both sexes and all age groups.

**Table 6-5 Population Count by Regional Corporation**

Municipality	Communities	2000 Population
San Fernando City Corporation	21	55,419
Princes Town Regional Corporation	3	4,280
Penal/Debe Regional Corporation	11	29,316
<b>TOTAL</b>		<b>89,015</b>

The annual growth rate of the population was suggested in WASA's Water and Wastewater Master Plan; which is attached in **Appendix E.4**. The projected population based on these growth rates for 2009 and 2010 was estimated at 93,873 and 94,418, respectively (**Appendix E.4**).

Satellite imagery from 2009 was used to manually count buildings in the project area. This was used to calculate the population for the project area where the average occupancy was assumed to be 3.5 persons per dwelling. This figure was proved to be accurate based on findings from the social survey (Figure 6-7). The manual housing count method averaged the population of 2009 to be 90,200 for the project area. This value was used to determine the estimated design population for the year 2035 using the Master Plan growth rates; this value was computed to 101,195 persons in the study area. These calculations are appended in **Appendix E.4**.

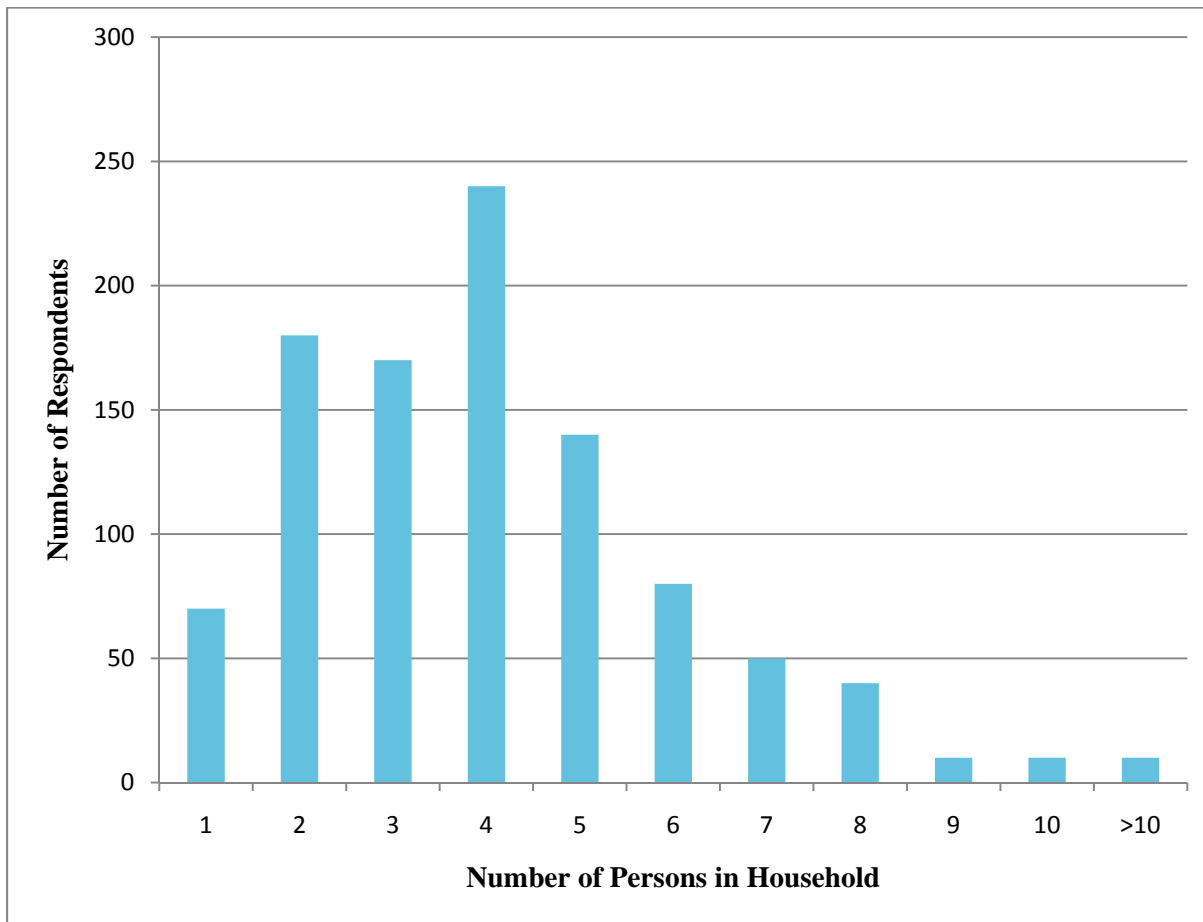


Figure 6-7 Number of Persons in Household, Social Survey 2010

### 6.10.2 Age

The age distribution of the San Fernando Wastewater Catchment was obtained from the 2000 Census and the social survey conducted. As illustrated in Figure 6-8, the highest age group in both sexes is the 20 to 35 year bracket. The age structure of the San Fernando Municipality is typical of slow growth where the younger and older age groups comprise a smaller percentage of the population. In comparison, a higher percentage of the population is within the 20 to 65 year age range. This configuration was possibly due to a ‘baby boom’ that has since subsided.

The social survey done for this project depicts similar results where the majority of the population was between the ages of 20 to 65, with the 20 to 44 age bracket having a higher percentage. The age distribution of the social survey is slightly different and has more characteristics of a negative growth since the younger and older age groups comprise a considerably lower percentage of the population.

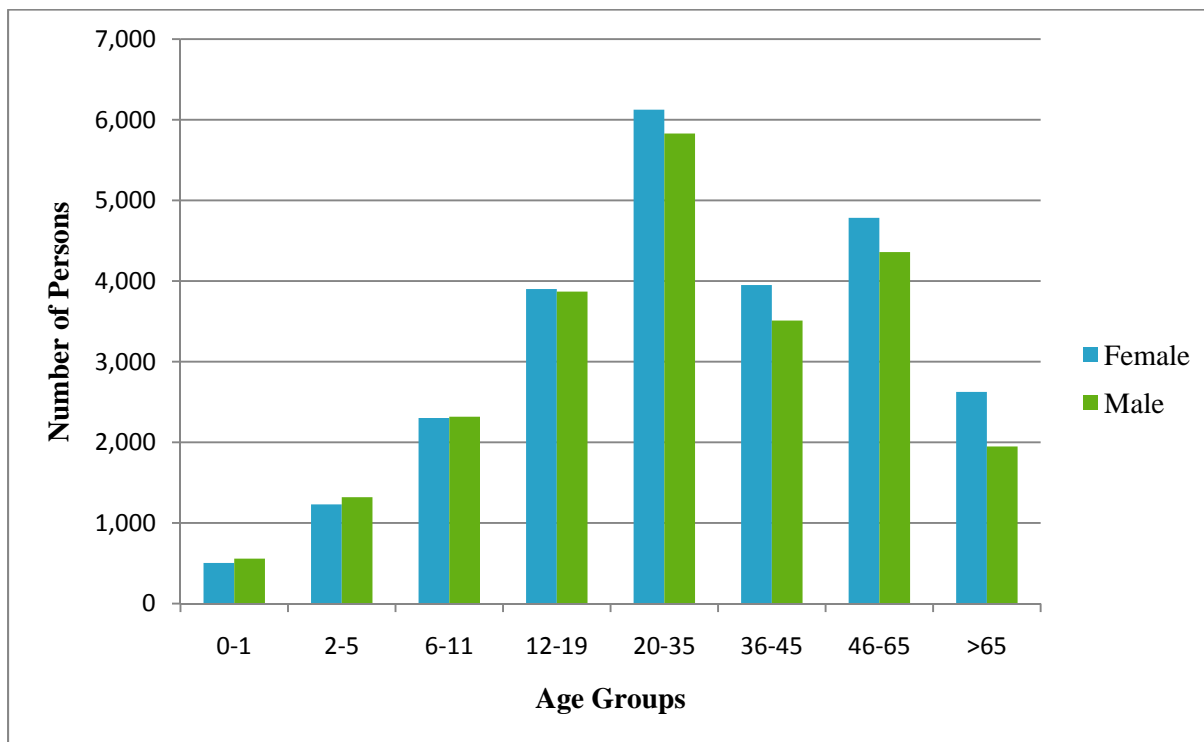


Figure 6-8 Age-Sex Distribution in San Fernando City Corporation (Central Statistical Office, 2002)

### 6.10.3 Religion

The religious composition of San Fernando City Corporation is composed chiefly of the religions listed in Figure 6-9. The most popular religious group are Roman Catholics, followed by members of 'Other' religions not listed in the Census. Anglicans comprise the third largest religious sector with approximately 11% of the surveyed population. Most of the churches are located within the boundaries of the City of San Fernando therefore residents of surrounding communities that are expected to be serviced through the San Fernando Wastewater Collection System would partake in the religious activities in the City centre.

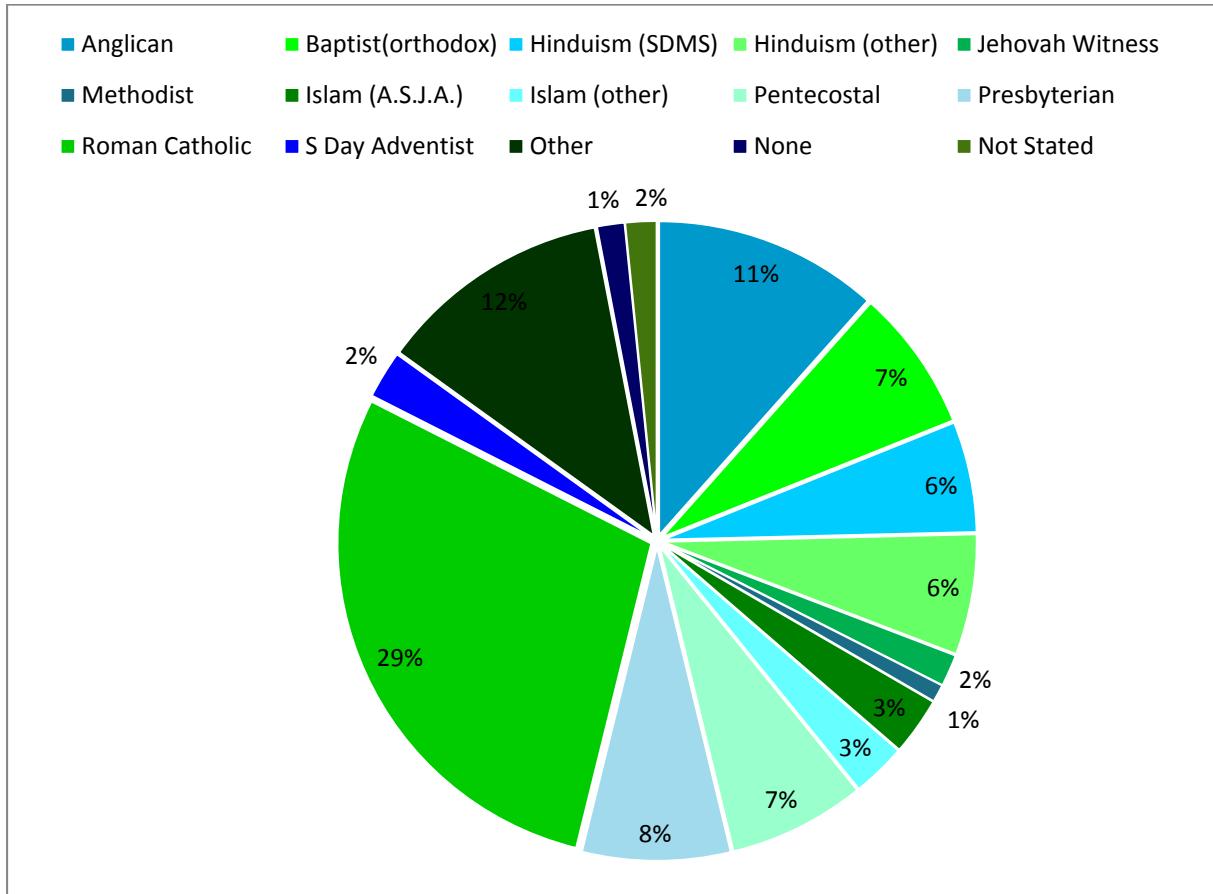
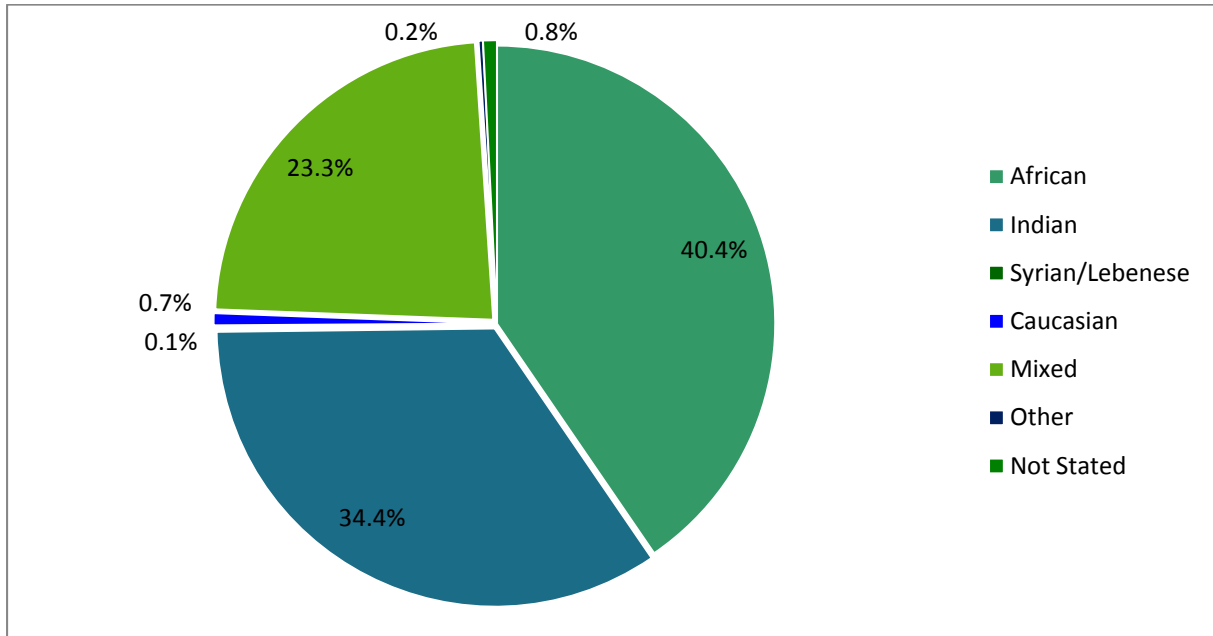


Figure 6-9 Religious Composition of San Fernando Municipality (Central Statistical Office, 2002)

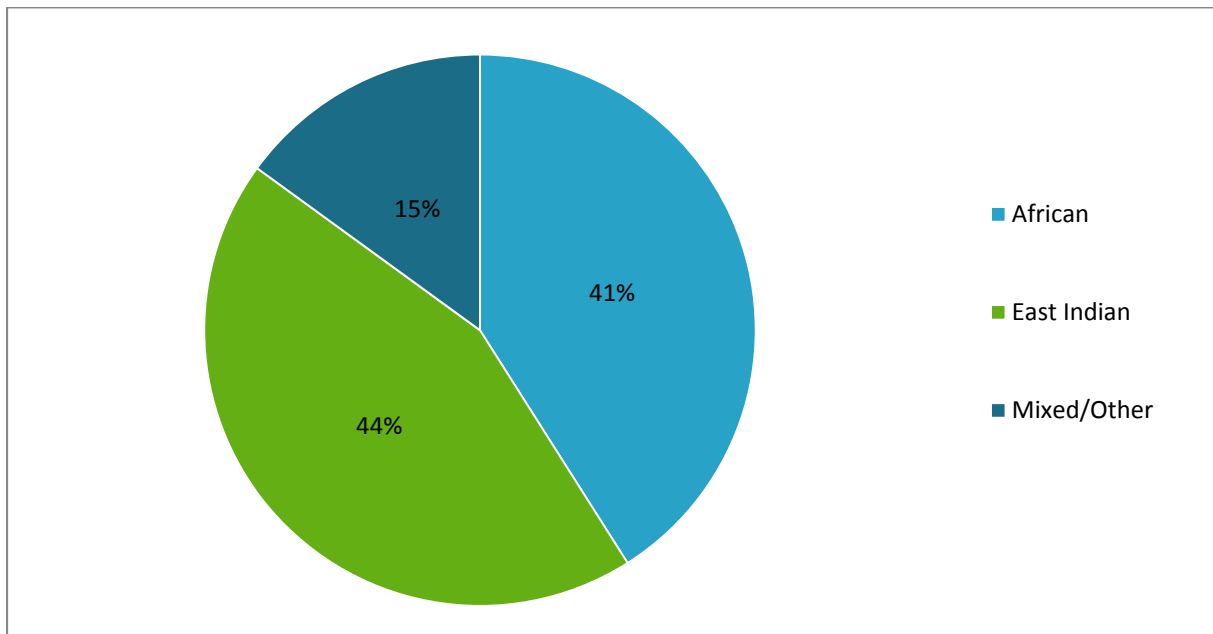
#### 6.10.4 Ethnicity

The ethnic structure of the San Fernando Wastewater Catchment comprises of 40% Africans, 34% Indian and 23% Mixed (Figure 6-10). The other residents are Caucasian, Syrian/Lebanese and of ‘Other’ ethnic groups.



**Figure 6-10 Ethnic Composition of San Fernando City (Central Statistical Office, 2002)**

The social survey 2010 also explored ethnic statistics within the communities that would be sewered. These however were limited to the racial classification of the respondent and not necessarily all the residents, Figure 6-11 describes the ethnicity of the respondents of the social survey.



**Figure 6-11 Ethnicity of Respondents of Social Survey 2010**



## 6.11 Quality of Life

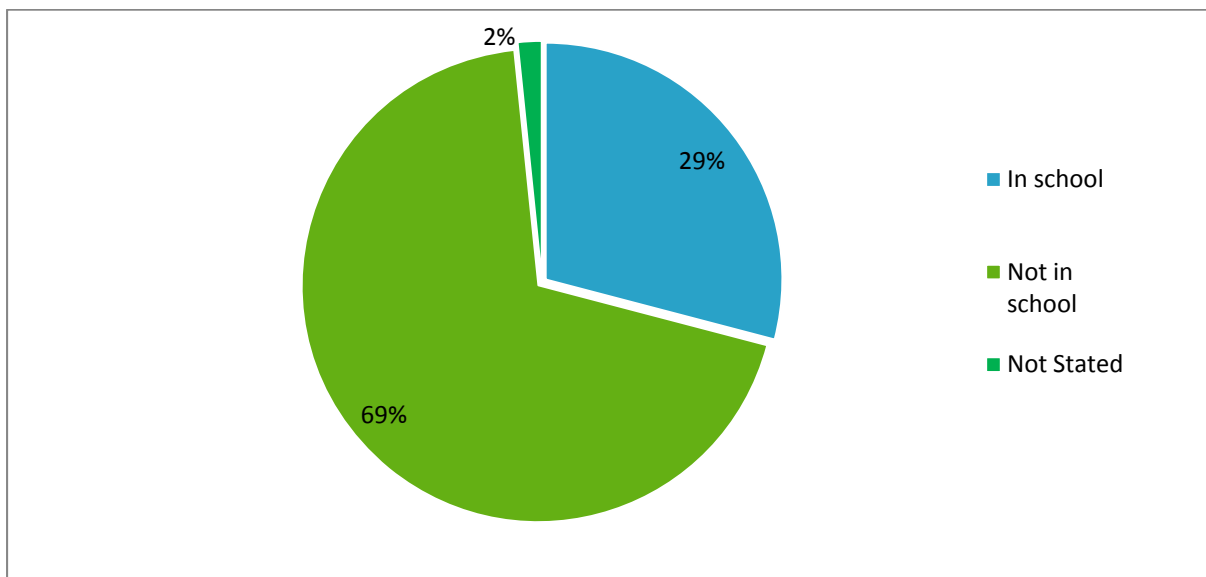
The quality of life is defined by the United Nations as a “notion of human welfare (well being) measured by social indicators rather than by “quantitative” measures of income and production” (UN Statistics Division). The quality of life is a direct representation of the socio-economic status of the population. The 2000 Census explored the statistics for socio-economic characteristics such as education and housing.

The social survey executed for the San Fernando Wastewater Project used a point system to identify the socio-economic status. The different occupations, levels of education and household items were ranked and calculated to place a numerical value to the quality of life of the dwelling and respective individuals. The rank and calculations are attached in **Appendix E.5**.

This section will discuss the socio-economic characteristics as a means of classifying the quality of life of the population. These indicators include; employment (Section 6.7), education, housing, water, sewer, electricity, telecommunications and transport. The availability of social services is also an indicator of the quality of life of a society; however, this will be discussed in Section 6.12.

### 6.11.1 Education

The level of education of a population is a critical indicator of the quality of life because it clearly depicts the production of a society and the economic vitality of the populace. The schools in the project area are discussed in Section 6.9.1. The 2000 Census data revealed approximately 69% of the surveyed area were not attending school during that period (Figure 6-12). The social survey of 2010 found that this figure decreased to 51% for this year.



**Figure 6-12 Status of Schooling for the period 2000 (Central Statistical Office, 2002)**



The 2000 Census also explored the level of education attained by the population, as well as the highest exam passed by the residents. This data is presented in Figure 6-13 and Figure 6-14.

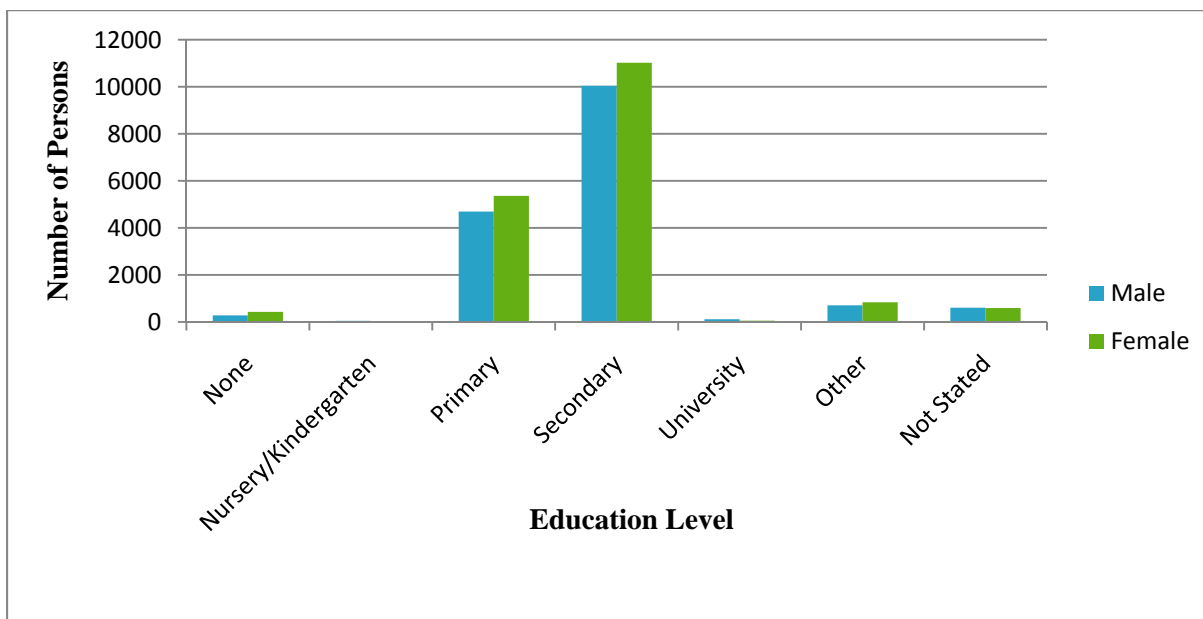


Figure 6-13 Highest Educational Attainment (Central Statistical Office, 2002)

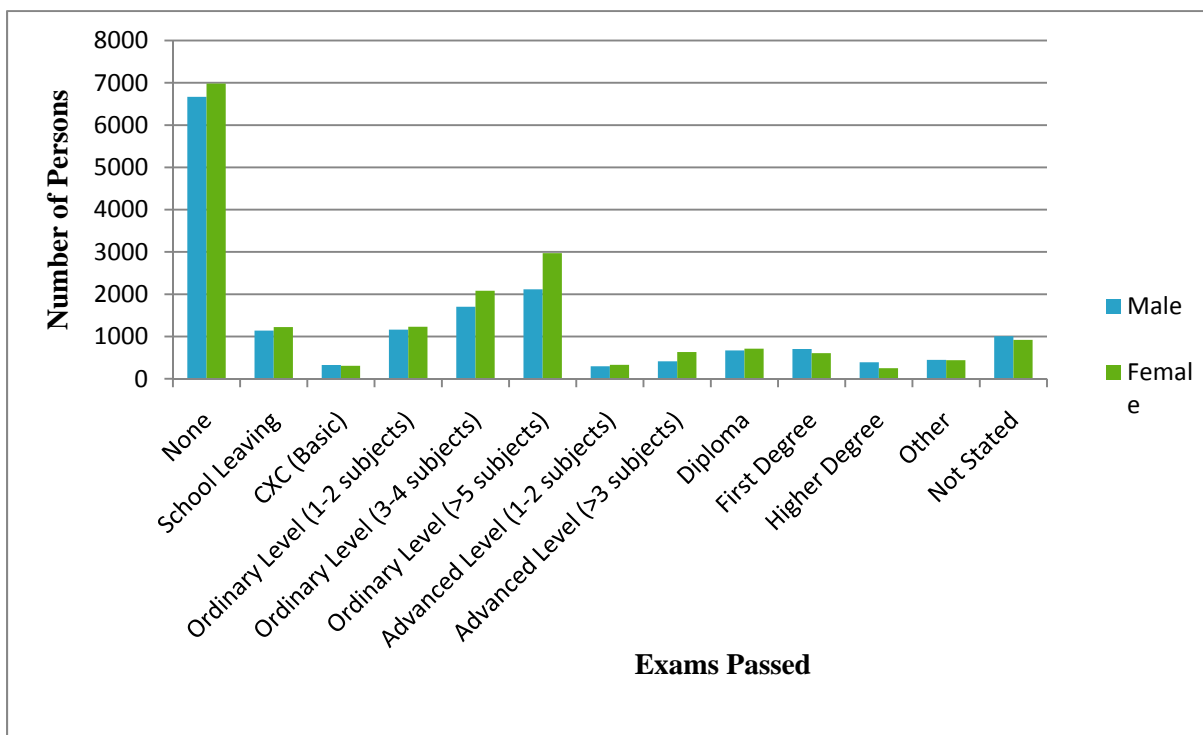


Figure 6-14 Highest Exam Level Passed (Central Statistical Office, 2002)



As depicted in these charts the majority of the population in the San Fernando City during the 2000 period only attained up to secondary level education and had achieved no academic certificates. In the 2010 social survey the majority of the persons attending school were at primary level and those that were enrolled in tertiary level institutions were primarily registered at the University of the West Indies (U.W.I.). This was still a major improvement compared to the 2000 Census results.

The 2000 Census, and social survey done by MFO in 2010 illustrates that the quality of life with respect to education was debatably low. A society with a high quality of life would have a greater number of persons attaining tertiary level education and achieving certificates for higher skills.

### 6.11.2 Housing

The tenancy arrangement and material used to build houses can be used to identify the quality of life of the residents. The social survey conducted in the project area investigated the type of housing material used in the areas assessed, Figure 6-15 represents these results. The majority of the residents built houses with both concrete and brick. This is a lower cost alternative in comparison to wood where only 3% of the residents constructed their houses with this material.

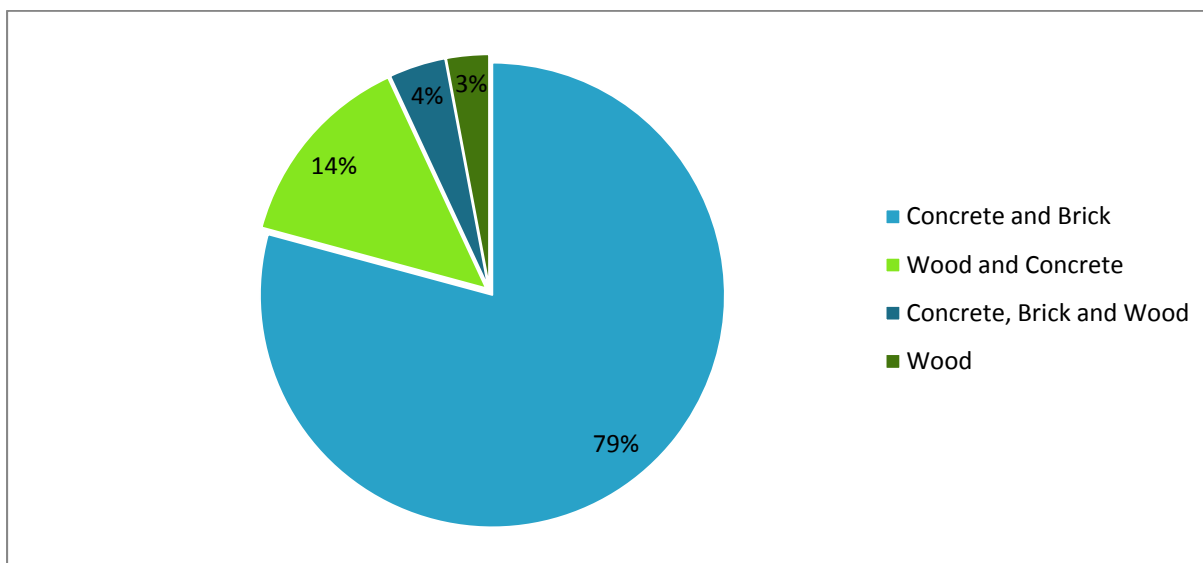
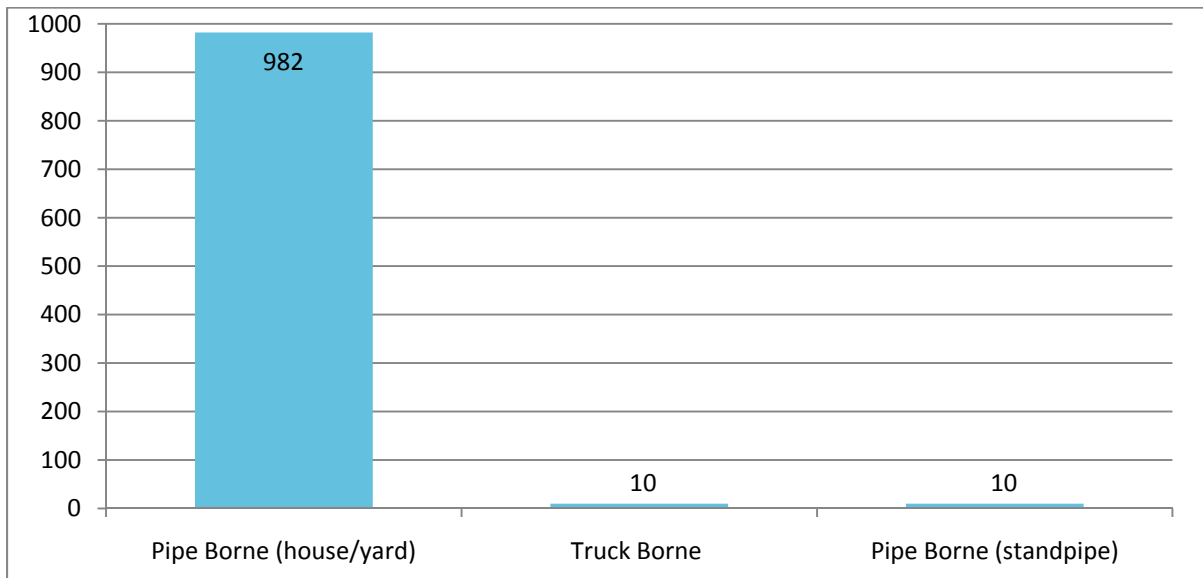


Figure 6-15 Housing Material in Surveyed Areas

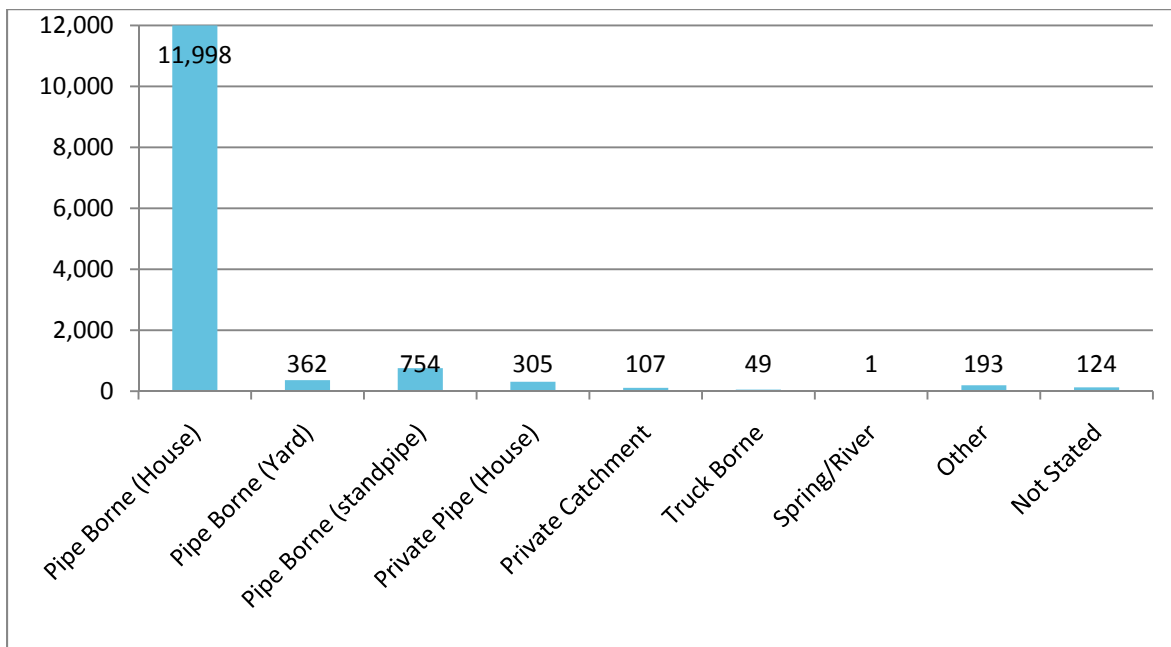
### 6.11.3 Water Supply

The ability to supply a population with domestic water is not only an indicator of a good quality of life but it is also an obligation of the governing body of the society. The social survey conducted in partial fulfillment of the TOR for this EIA investigated the domestic source of water for the residents of the San Fernando Wastewater Catchment. Figure 6-16 shows the findings of these investigations and Figure 6-17 shows the findings in the year 2000. 86% of the residents in San Fernando had domestic water in 2000 and 98% of residents in the wastewater subcatchment areas were supplied with pipe borne water directly to their houses or yard. This is a positive indicator of a good quality life, in comparison to some communities having to obtain domestic water from untreated sources such as rivers, rainfall and lakes. The supply of treated water to 98% of the surveyed area therefore displays a high standard of life.





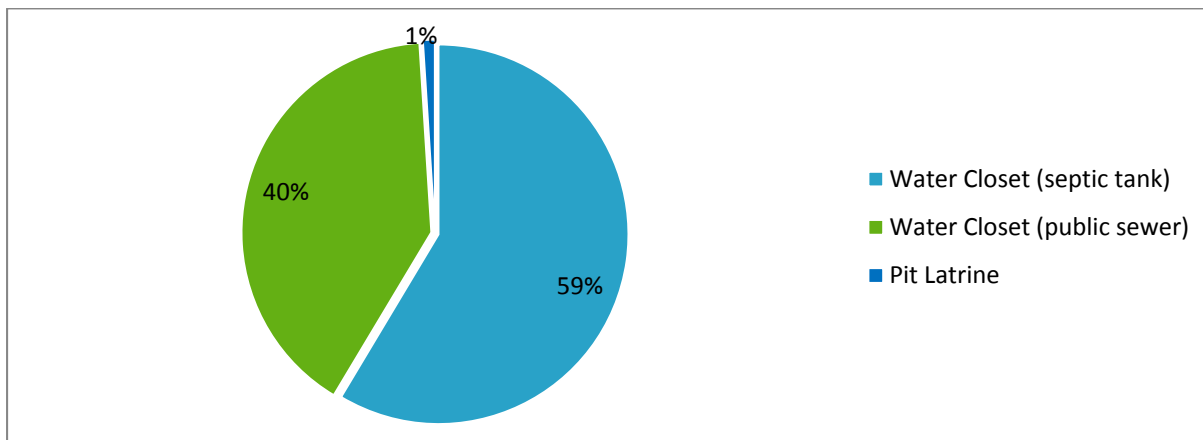
**Figure 6-16 Domestic Water Supply in San Fernando Wastewater Catchment**



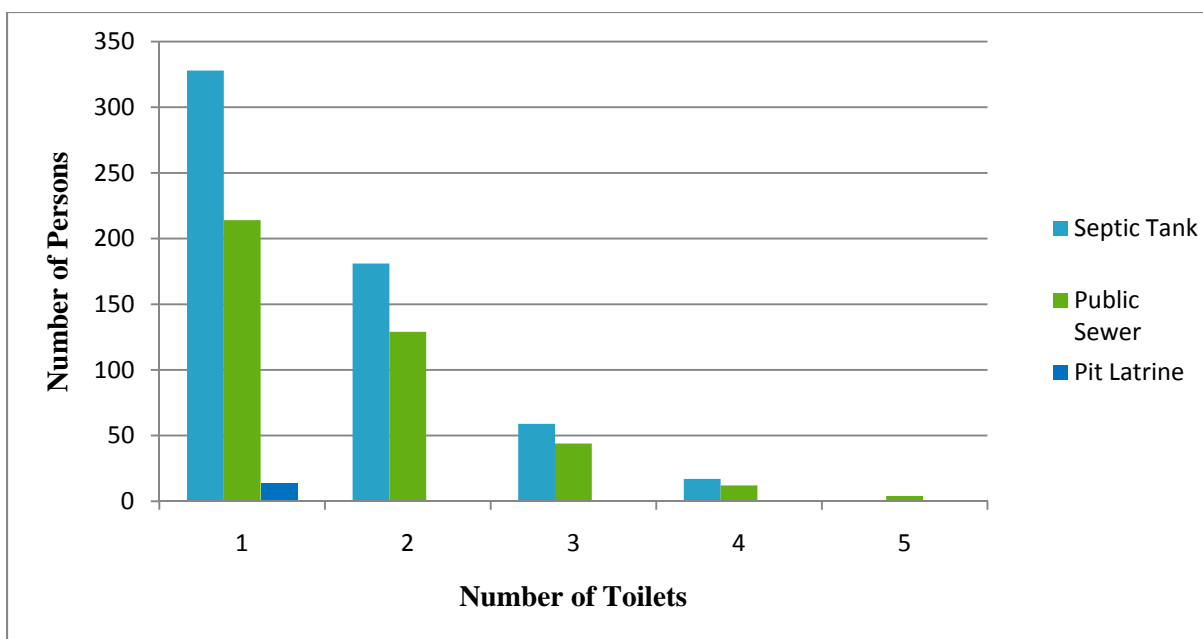
**Figure 6-17 Domestic Water Supply in the City of San Fernando (Central Statistical Office, 2002)**

#### 6.11.4 Sewer Collection

The toilet facilities and method by which the wastewater is disposed can be used to gauge the quality of life within a community. The social survey explored the type of toilet facilities in a household (Figure 6-18), the number of water closets in one dwelling and the type of disposal systems for the wastewater (Figure 6-19).

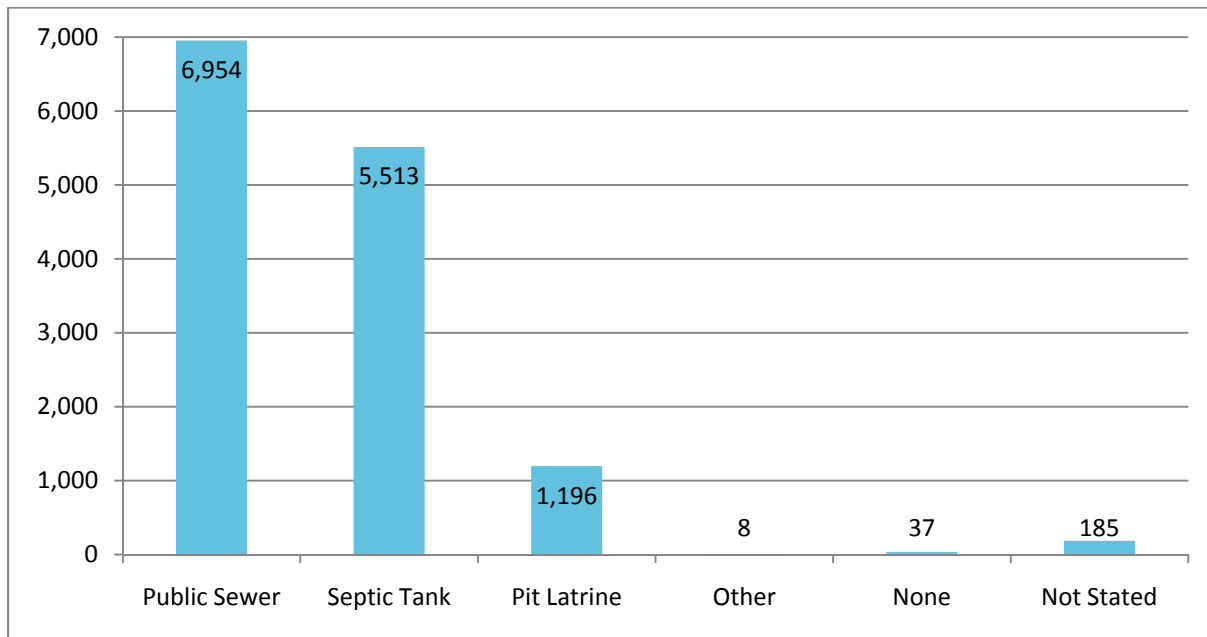


**Figure 6-18 Type of Facilities for Wastewater Disposal among Residents of the San Fernando Wastewater Catchment**



**Figure 6-19 Number of Toilets in Household and Type of Disposal Systems for Wastewater in Dwellings within the San Fernando Wastewater Catchment**

Figure 6-18 and Figure 6-19 depicts the outcomes of the social survey investigations into toilet facilities in the household. The 2000 Census also looked at toilet facilities in the San Fernando City, see Figure 6-20.



**Figure 6-20 Type of Toilet Facilities in the City of San Fernando (Central Statistical Office, 2002)**

The difference in survey results may be attributed to more residents interviewed for the 2000 Census in areas that are connected to the existing San Fernando wastewater collection system. The goal of the San Fernando Wastewater Project is to service all the residents so that wastewater can be disposed of efficiently and in an environmentally-friendly manner, thus improving the quality of life of the residents. This would eliminate septic tanks and pit latrines therefore eliminating major sources of pollution and enhancing the quality of human life from an environmental perspective.

### 6.11.5 Electricity Supply

Access to an efficient electricity supply demonstrates a high quality of life in a society. The social survey looked at electricity connection in the project area and the 2000 Census identified the different sources of electricity in the San Fernando City. The government is responsible for providing electricity for the population of Trinidad and Tobago; all households are supplied with electricity from T&TEC. Most of the residents acquire the power supply from this unit (Figure 6-21); all other sources are from an informal connection to a T&TEC electricity line. Figure 6-22 illustrates the results of the 2000 Census where most of the residents use electricity as their energy source. This has improved over the past ten years with the bulk of the populace currently utilizing electricity as the main power source.

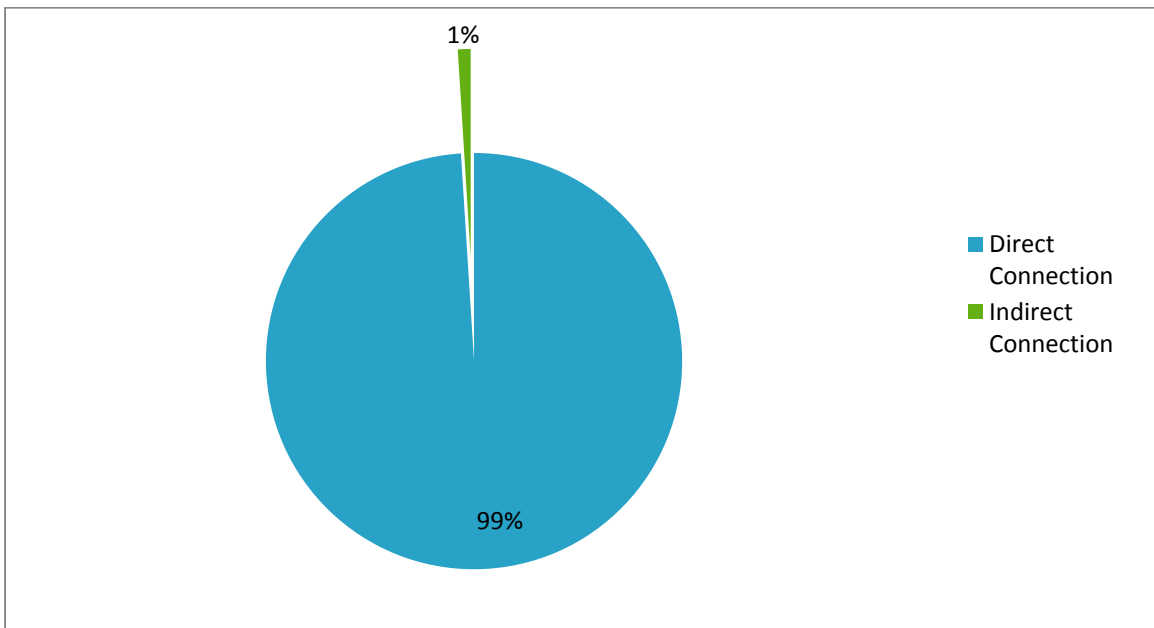


Figure 6-21 Type of Energy Source Connection in Project Area

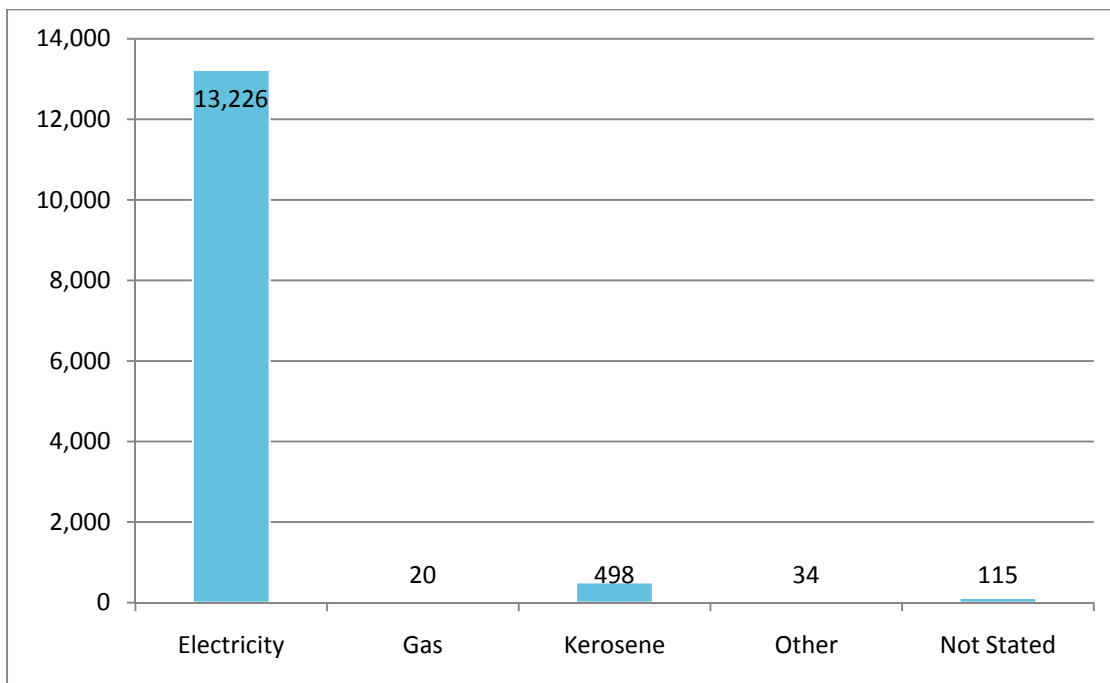


Figure 6-22 Household Energy Sources in San Fernando City (Central Statistical Office, 2002)

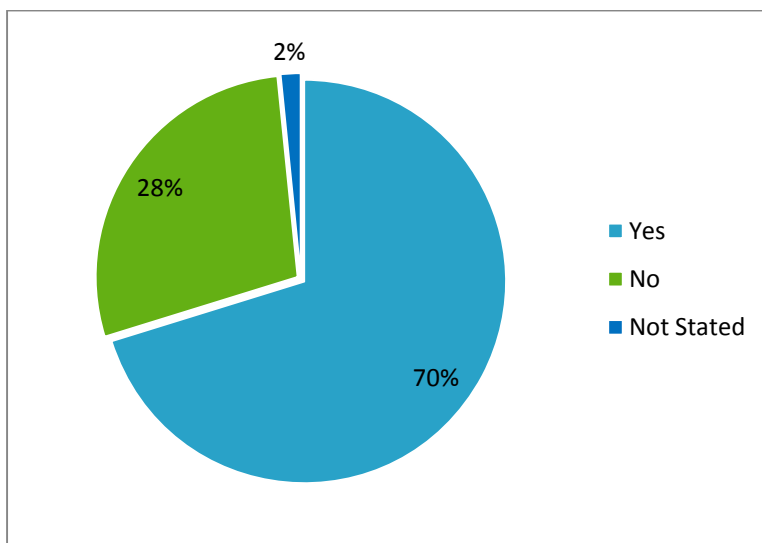


### 6.11.6 Telecommunications

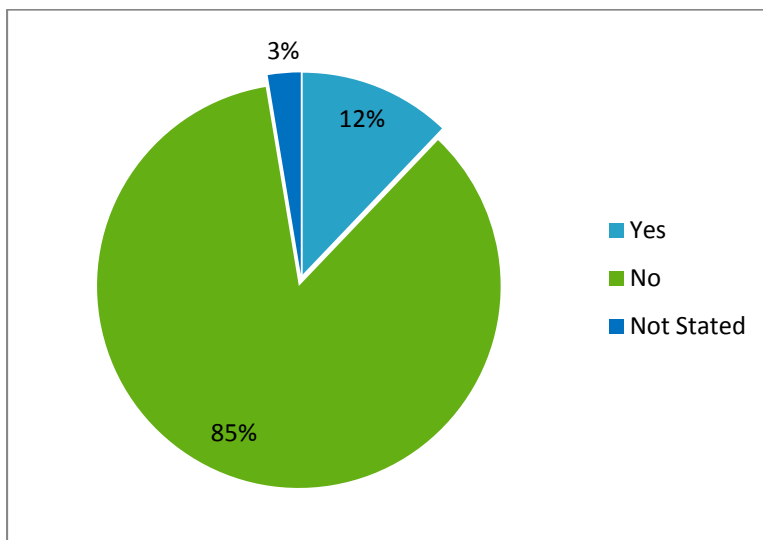
Telecommunications proves progression of technology in a society and is consequently a truthful indicator of the quality of life. In the San Fernando Wastewater Catchment area, there are two types of telecommunication services; telephones and the internet. The two main providers are:

- Telecommunication Services of Trinidad and Tobago (TSTT).
- Columbus Communications Trinidad Limited (FLOW).

These providers service most of the project area with TSTT being more established than FLOW because of its longer duration in Trinidad. FLOW has only been in existence for the past five years therefore infrastructure is still being installed to facilitate the access of services to the population of Trinidad and Tobago. The availability of telecommunication technology service to the residents of the San Fernando Wastewater Catchment denotes a high standard of living.



**Figure 6-23 Residents in the City of San Fernando with Telephones (Central Statistical Office, 2002)**



**Figure 6-24 Residents in the City of San Fernando with Internet (Central Statistical Office, 2002)**

Figure 6-23 and Figure 6-24 shows the results of the 2000 Census. Considerable improvement has been made over the last ten years in terms of population use of telecommunications; mainly the number of households with internet has increased.

### 6.11.7 Summary

In the 2009 door-to-door survey conducted by MFO, the socio-economic status was ranked as:

**Table 6-6 2009 Socio-Economic Status for San Fernando Project Area**

Socio-Economic Status Ranking	Percentile
Low	35
Middle	57
High	8

These results are based on the previously discussed socio-economic characteristics. As seen in Table 6-6, approximately 60% of the population ranks within the middle socio-economic group.

## 6.12 Social Services

Social services can be described as any institution that the Government of Trinidad and Tobago provides for the population. Social services may be free for citizens of the country or the cost may be partially subsidised by the Government. This section will be discussed based on the following themes:

- Health Care
- Transportation
- Education
- Protective Services



### 6.12.1 Health

The health care available to residents in the San Fernando Wastewater Project area includes clinics, health centres and a general hospital. Within the project area, there is one hospital, the San Fernando General Hospital, which services the residents of the entire portion of south Trinidad. This institution carries out a range of primary and secondary health care functions. The San Fernando Chest Clinic is another specialised health facility in the study area. There are a number of health centres in the San Fernando Wastewater Catchment (Table 6-7) which provide health care services to the surrounding communities.

**Table 6-7 Health Centers in Project Area**

Health Centre	Address
Debe	Wellington Road, Debe
Gasparillo	Church Street, Gasparillo
Pleasantville	Chaconia Avenue and Prince Albert Street, Pleasantville
La Romain	Zaida Lane, La Romain
Marabella	Market Street, Marabella
Ste. Madeline	Manahambre Road, Ste. Madeline

All the health institutions in the project area are managed by the South-West Regional Health Authority. Even though some of the organisations may not be located within the boundaries of the project area, such as the Debe Health Centre, the persons living in the study area are still serviced by these institutions.

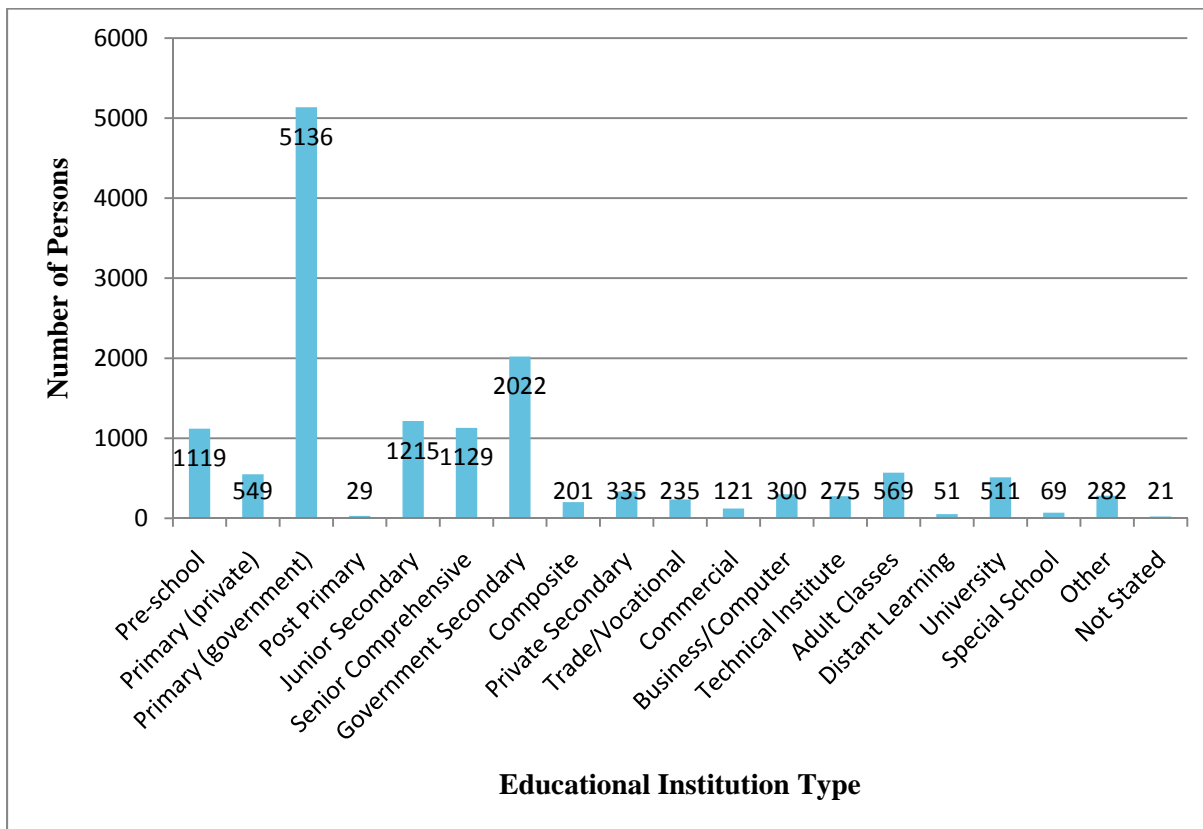
### 6.12.2 Transport

Transport in Trinidad and Tobago is considered a social service since the Government subsidises the cost of public transport throughout the country. The service is subsidised by the Government and is afforded to the public at an inexpensive cost. In the San Fernando Wastewater Project area, there are two main sources of public transport; buses and a water taxi service. The bus service is managed by the Public Transport Service Corporation (PTSC) and the main hub is located on the King's Wharf in the City of San Fernando. All the buses drop off and collect passengers at this point and transport to all areas in the country can be accessed from this hub.

The water taxi service is administered by the National Infrastructure Development Company (NIDCO) and comprises of boats that transport passengers from San Fernando to Port-of-Spain and return on a daily basis. The water taxi terminal is also located on the King's Wharf in San Fernando and operates only on working days.

### 6.12.3 Education

Education in the project area can be either government funded, government assisted or privately funded. The list of all the primary, secondary and tertiary level schools in the area is attached in **Appendix E.3**. The 2000 Census assessed the type of schools the residents were enrolled in; the findings are presented in Figure 6-25.



**Figure 6-25 Type of School Persons Enrolled in the City of San Fernando (Central Statistical Office, 2002)**

In the communities observed in the social survey undertaken for this project, the largest percentage of students attending primary school was enrolled in the San Fernando Boys R.C. Primary School located on Harris Promenade. The largest percentage of secondary students within the project area attended the Pleasantville Senior Comprehensive School on Collector Road, despite a fairly even distribution among the other secondary institutions. Among the tertiary level students, most of them were registered at U.W.I.

The Government also funds a number of social programmes to teach citizens different trade and vocational skills. This is organised by the Ministry of Community Development, Culture and Gender Affairs and are usually hosted in the community centres. Another educational institution under the Government within the project area is the Multi Sector Skills Training Programme (MUST) which seeks to equip interested nationals with different construction skills. This programme is useful to the construction phase of this project as graduates residing in the wastewater catchment could be targeted as potential employees for the San Fernando Wastewater Project.





#### 6.12.4 Police

The Police Force in the San Fernando Wastewater Catchment Area has branches throughout the project area. They are as follows:

- San Fernando Police Station
- Marabella Police Station
- Mon Repos Police Station
- Ste. Madeline Police Station
- Gasparillo Police Station
- Debe Police Station

The sphere of influence of each police station is usually determined by the location which an incident has taken place, similar to the operation of the municipal and supreme courts. Therefore persons residing in all different communities may be serviced by different police stations based on the location of the event. In the social survey done for this project, approximately 70% of residents were satisfied with the police service, in comparison to 29% who were not.

#### 6.12.5 Fire

There is only one fire station in the entire study area; the San Fernando Fire Station located on the San Fernando By-Pass. 90% of the population surveyed in 2010 were satisfied with the fire service available in the area while 8% were not. This institution is administered by the Ministry of National Security and emergency response is only given to areas within close proximity to the station. With respect to the study area, any emergency in the subcatchments will be addressed by the San Fernando Fire Station.

### 6.13 Social Survey

The social survey was conducted over a two week period in December 2009 by sub-consultant MFO, and a report of the findings was prepared and is attached in **Appendix E.6**. The objectives of the social survey were to:

- Describe the population demographics in the study area.
- Explain the socio-economic characteristics of the population.
- Identify the popularity of the project.
- Identify perceived attitudes and concerns associated with the project.

The following sections seek to explain the methodology used to undertake the social survey and the perceptions of the percentage of the population interviewed.

#### 6.13.1 Methodology

The sub-consultant MFO employed approximately twenty individuals to conduct field surveys within the subcatchments of the San Fernando Wastewater Project. The areas specifically targeted were analogous to the communities in which wastewater infrastructure was proposed under this project. The field investigators conducted exclusive interviews with the household head of the respective home. Queries were made on the following themes:



- Project awareness
- Perceived impact of the project
- Community structure
- Household characteristics
- Demographics of the household
- Socio-economic characteristics

The findings of this survey are discussed in the following sections and the population demographic conclusions were examined in previous sections.

### 6.13.2 Socio-Economics

The survey investigated the socio-economic characteristics of the household by inquiring about specific items and belongings of the household. This variable along with the occupation and level of education was identified in the field investigation. These variables were ranked by MFO and the values are placed in **Appendix E.5**. A calculation was formulated to determine the socio-economic status of the project population. Typically, a household with a low economic status only had between 3 and 7 points. A middle economic standing would have been calculated between 8 and 17 points and a high economic status measured between 18 to 25 points. The majority of the persons, approximately 57% within the study area were within the middle socio-economic bracket while 35% of the respondents were of a low economic standing. The community with the highest percentage of a high economic population was Gulf View, where 32% of the residents had a high socio-economic status and 55% with a middle socio-economic rank.

### 6.13.3 Project Awareness

The social survey identified that only 22% of the assessed population were informed about the project. In this bracket, 74% of these individuals were made aware six months prior to the interview (Figure 6-26). The media was identified as the main informant of the project to the citizens. The first public consultation was held on January 26, 2010 therefore advertisement for this session would have increased the awareness of the proposed project in the study area.

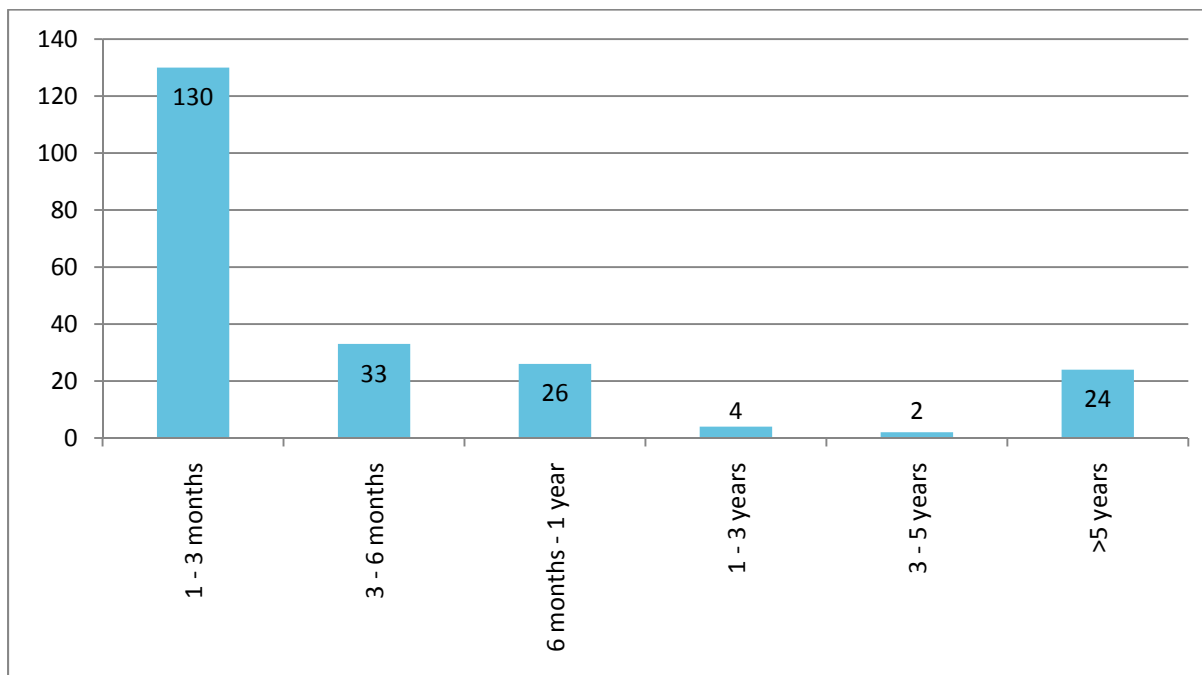


Figure 6-26 Length of Awareness of San Fernando Wastewater Project

#### 6.13.4 Perceived Impacts and Concerns

The MFO researcher specifically enquired as to the perceived impact of the project on different characteristics of the individual's life, which incorporated personal impact, community impact and the impact of the project to various aspects of the environment. Generally 78% of the respondent perceived a positive impact of the San Fernando Wastewater Project. The majority of the residents (38%) identified the improvement of the environment, specifically health and cleanliness, as the major positive consequence of this plan. Whereas 51% of the respondents who perceived a negative impact indicated that the main basis of their perceived negative impact was the costs or that their WASA bill would increase.

The survey also assessed the benefit to the community of the San Fernando Wastewater Project and 85% of the population sensed a positive benefit where a cleaner and healthier environment would be produced as a result.

The respondents were asked to identify whether there would be a positive or negative impact on:

- Human Beings
- Ocean/Rivers/Drains
- Lands
- Animals/Plants
- Roads
- Air

Approximately 94% of the persons interviewed perceived a positive impact to human beings and the project was recognised as a benefit to the aquatic environment and air quality in the area. The main



justification of the positive impact to human beings is via cleanliness and health of the environment, while the negative impact to human beings was because of the economic aspects of the project.

The proportion of the population who were of the opinion that the San Fernando Wastewater Project would have a negative effect (22%) on the aquatic environment rationalised that it would be as a result of dumping and spillage of waste and chemicals that would pollute these habitats. A positive impact to air quality was recognised by 40% of the surveyed residents where a healthier, unpolluted atmosphere would be created as a result of this project. The respondents who sensed a negative effect on air quality attributed it to chemical use.

Half of the residents believed that there would be no impact to animals/plants in the area while the percentage that were of the opinion that there would be a positive effect accredited it to the animals and plants having access to a cleaner water supply. In comparison, the residents who believed the consequence would be harmful assumed this would be due to pollution of the water supply.

Similarly, approximately half of the respondents perceived no influence of the San Fernando Wastewater project to the land. The positive impact would be less erosion since drainage would be channelled while the negative impact identified would be land erosion according to the residents.

The environmental aspect which received the most negative ratings was the impact of the project to roads in the area where 45% of the respondents were of this opinion, their main reasoning being this was the destruction of the road network. In contrast those who envisioned a positive effect recognised that it would be as a result of a reduction of flooding on the road ways.

The developments that have occurred in the San Fernando Wastewater Project area were examined and the residents were questioned on whether the impact has been negative or positive, with the majority (76%) conveying a negative outcome of these developments. The major constructive consequence was more shopping and commercial activity while the chief negative impact was that the developments resulted in increase traffic in the areas.

Community nuisances were studied, with the three highest ranking being traffic (30%), odour (28%), and crime (26%). Untreated wastewater was a nuisance to 11% of those surveyed. Those communities that ranked 5% higher than the average were:

- La Romain
- Picton
- Duncan Village
- Green Acres
- Hermitage

All of these areas are presently not connected to the existing San Fernando Wastewater Collection System but are incorporated in the new wastewater design. It is suspected that those affected by odour are also being affected by untreated wastewater, and this is the source of some of the odours.

The assessment sought to identify an average range at which a resident will pay for a sewer service on a household basis. A significant fraction of the population indicated that they were willing to pay between TT\$1 to TT\$45 for the service. While one quarter of the residents felt that no increase should be charged for the service, Table 6-8 conveys a summary of the preferred price for sewer service.

**Table 6-8 Preferred Price for Sewer Service (Quarterly Rate)**

Price (TT\$)	Response (%)
\$1 - \$45	49
\$46 - \$65	8
\$66 - \$85	5
\$86 - \$104	9
\$105 or more	3
Nothing/Unwilling for Increase	25
Unsure	1

Interestingly, 40% of the respondents indicated that an irregular water supply was their main concern with bad roads (23%) and crime (18%) proceeding. Marabella and Picton were most affected by the irregular water supply with Picton being concerned most with bad roads. The area with the highest concern for crime in the community was San Fernando.

## 6.14 Road Traffic Survey

Construction of the collection system will occur on road right-of-ways, so determination of the impact to traffic will be important for the overall project impacts and mitigation. Understanding the existing traffic situation in the San Fernando area will provide baseline data in order to determine these impacts.

The principal routes for movement into the central parts of San Fernando from the northern and southern districts of the city are:

- Southern Main
- South Trunk Road
- San Fernando By-Pass

Traffic from central and northern Trinidad uses mainly the Solomon Hochoy Highway or the Old Southern Main Road to get to San Fernando. Surrounding communities located on the outskirts of San Fernando Wastewater Catchment area can be accessed via the Guaracara- Tabaquite Road, Naparima-Mayaro Road, Manahambre Road, and the M1 Tasker Road.

In San Fernando the main arterial routes are the San Fernando By-Pass, Connector Road, Lady Hailes Road, Tarouba Link Road, Naparima Mayaro Road, and Guaracara Tabaquite Road.

Construction of the collection system will occur along, or cross under all of these roads mentioned above.



Traffic counting was conducted March 23-25, 2010 at the locations noted in Figure 6-27. Monitoring consisted of three periods of 3-hour intervals during morning, noon and afternoon. These times were:

- 6am-9am
- 11am-2pm
- 3pm-6pm

Counting was conducted by one individual for each lane of traffic. The traffic count numbers were divided into vehicle types.

Roads that were selected for traffic counting were roads that are functioning as arterial, and where there is proposed collection system construction. The results from the counting are displayed in Table 6-9.

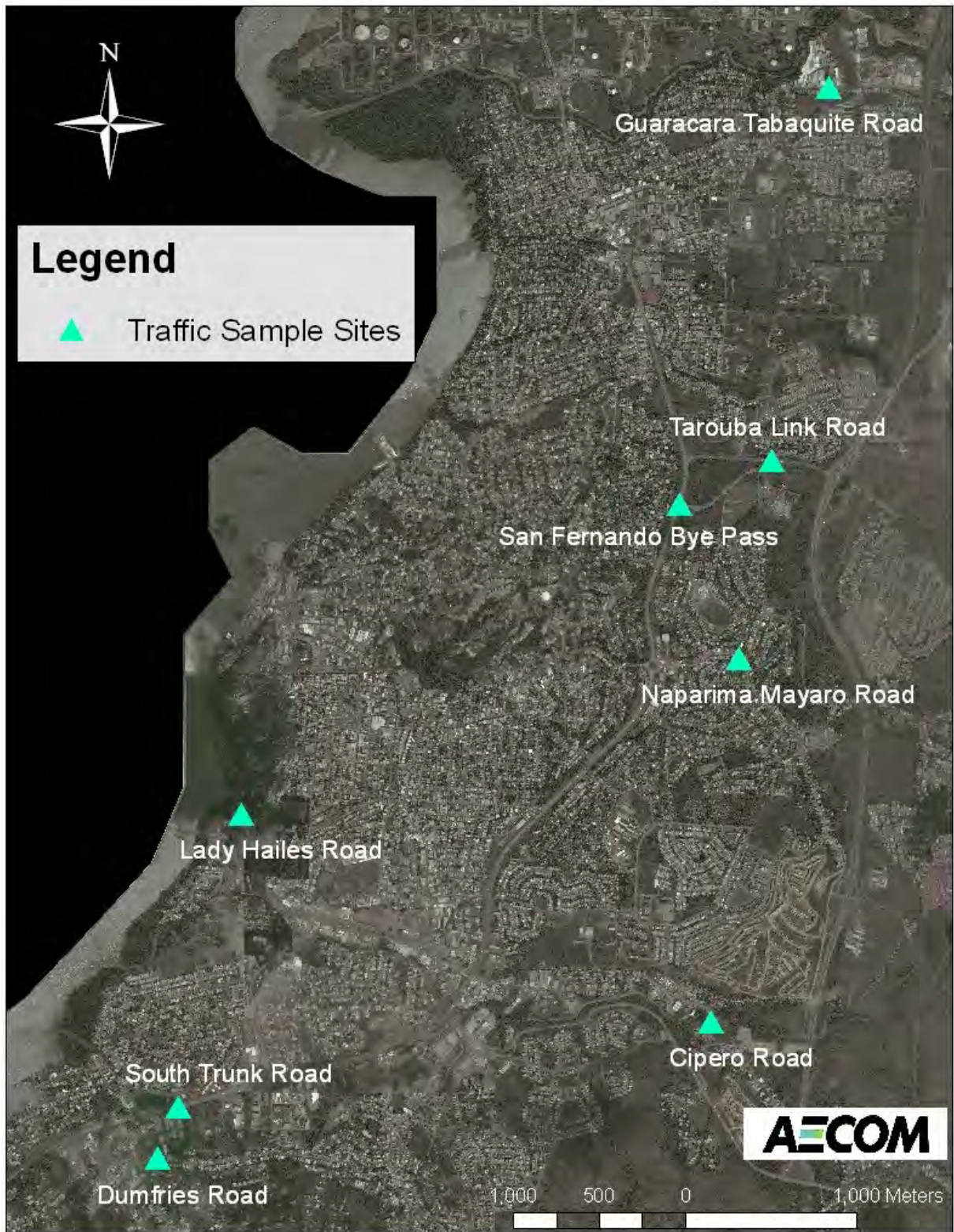


Figure 6-27 Traffic Sampling Locations



**Table 6-9 Traffic Counting Results, March 23-25, 2010**

Location		Time Period		Direction of Traffic	Vehicle Type						Count Summary		
Street Name	Total No. Lanes	Start	End		Motorcycle	Passenger Vehicle (Car, SUV, Recreational Truck)	Light Service Truck	Heavy Truck/Construction Equipment	Bus/Maxi Taxi	Total Count	Total Count Overall	Vehicles Per Minute	
San Fernando By-Pass	4	6am	9am	N	4	4,279	200	70	92	4,645	25,121	47	
				S	6	3,379	406	141	76	4,008			
		11am	2pm	N	7	3,938	289	54	34	4,322			
				S	8	2,948	333	175	53	3,517			
		3pm	6pm	N	10	4,341	196	59	63	4,669			
				S	8	3,537	220	115	80	3,960			
Guaracara Tabaquite Rd	2	6am	9am	E	1	1,139	24	72	10	1,246	9,420	17	
				W	4	1,730	69	57	14	1,874			
		11am	2pm	E	3	1,374	92	58	10	1,537			
				W	2	1,241	102	67	7	1,419			
		3pm	6pm	E	1	1,691	65	23	10	1,790			
				W	-	1,456	64	20	14	1,554			
Naparima-Mayaro Rd	2	6am	9am	E	2	1,377	28	10	111	1,528	10,839	20	
				W	-	1,531	53	16	80	1,680			
		11am	2pm	E	3	1,664	49	9	69	1,794			
				W	1	1,513	80	19	62	1,675			
		3pm	6pm	E	3	2,229	49	18	93	2,392			





**Table 6-9 Traffic Counting Results, March 23-25, 2010 (continued)**

Location		Time Period		Direction of Traffic	Vehicle Type						Count Summary		
Street Name	Total No. Lanes	Start	End		Motorcycle	Passenger Vehicle (Car, SUV, Recreational Truck)	Light Service Truck	Heavy Truck/Construction Equipment	Bus/Maxi Taxi	Total Count	Total Count Overall	Vehicles Per Minute	
Naparima-Mayaro Road	2	3pm	6pm	W	3	1,634	58	13	62	1,770			
				N	-	2,166	700	73	1,140	4,079			
Lady Hailes Rd	2	6am	9am	S	-	1,685	42	15	235	1,977			
				N	4	1,510	219	36	188	1,957		26	
		11am	2pm	S	2	950	73	13	91	1,129			
				N	4	2,365	707	69	935	4,080			
		3pm	6pm	S	3	706	66	8	110	893			
				N	1	762	34	11	4	812			
Dumfries Rd	2	6am	9am	S	-	617	34	10	5	666			
				N	-	621	34	23	4	682		10	
		11am	2pm	S	-	869	29	23	6	927			
				N	-	594	29	15	2	640			
		3pm	6pm	S	2	1,354	38	32	17	1,443			
				E	1	906	50	51	42	1,050			
Cipero Rd	2	6am	9am	W	3	1,781	37	17	67	1,905			
				E	1	1,208	58	50	16	1,333		17	
		11am	2pm	W	3	887	45	26	46	1,007			
				E	-	2,228	73	46	33	2,380			



**Table 6-9 Traffic Counting Results, March 23-25, 2010 (continued)**

Location	Time Period		Direction of Traffic	Vehicle Type					Count Summary			
	Total No. Lanes	Start		End	Motorcycle	Passenger Vehicle (Car, SUV, Recreational Truck)	Light Service Truck	Heavy Truck/Construction Equipment	Bus/Maxi Taxi	Total Count	Total Count Overall	Vehicles Per Minute
Cipero Road	2	3pm	6pm	W	2	1,178	64	22	29	1,295		
				NE	1	3,205	136	86	65	3,493		
South Trunk Road				SW	1	2,147	123	145	110	2,526		
	4	11am 2pm		NE	-	2,226	180	159	46	2,611	16,528	31
			SW	2	2,183	165	174	104	2,628			
		3pm	6pm	NE	1	2,075	169	156	44	2,445		
			SW	-	2,332	202	174	117	2,825			
Tarouba Link Rd	2	6am	9am	E	1	4,430	875	177	170	5,653	24,033	45
				W	1	3,370	78	42	47	3,538		
		11am	2pm	E	2	3,810	465	103	49	4,429		
	W			3	2,688	173	71	54	2,989			
		3pm	6pm	E	3	3,325	1,080	62	65	4,535		
	W			4	2,554	221	53	57	2,889			



Overall, the results of the traffic count study show high volumes of traffic on these roads within the project area, confirming that these roads are arterial for the San Fernando area.

The San Fernando By-Pass had the highest reported traffic volumes. When looking at the patterns throughout the day, there was more traffic during the morning and afternoon than the noon period. During the noon and afternoon periods, the traffic load in the north bound lanes was slightly higher than the south bound lanes.

On several roads, traffic patterns indicated that the highest volumes of traffic encountered are entering the core of the project area during the morning, and leaving in the afternoon. On the Naparima-Mayaro Road, and Ciperio Road, traffic driving west, entering the project area in the morning was slightly higher than the eastbound traffic. During the noon and afternoon periods, there was a higher volume of traffic leaving the project area. On Dumfries Road, in the morning there was more traffic driving north, towards the South Trunk Road, while the noon and afternoon sampling had higher traffic volumes entering the residential area. The South Trunk Road had higher numbers travelling northeast in the morning into San Fernando, and heading southwest, leaving San Fernando in the afternoon. The highest traffic volumes encountered were during the afternoon.

On the Guaracara-Tabaquite Road during the morning period, 60% of the traffic volumes were in the westbound lanes, entering Marabella and San Fernando. In the afternoon, the highest traffic volumes were encountered, with traffic volumes in the eastbound lanes accounting for 54% of the traffic volume. These results indicate that this road is used for commuters entering or leaving the project area for typical daytime jobs, or schooling. The higher difference in the morning may be attributed to the road network entering the project area. Another nearby entrance to the area is the Tarouba Link Road, however when entering from the Tarouba Link Road, the driver is unable to drive north into Marabella. This would increase the amount of traffic entering the project area by the Guaracara-Tabaquite Road.

The Tarouba Link Road had the second highest traffic volumes recorded, however this traffic is unbalanced, with 61% of the total volumes travelling east towards the Solomon Hochoy Highway. This unbalance may be due to the design of the road networks. Westbound traffic must turn south at the San Fernando By-Pass, making it difficult to enter Marabella. At the time of the road count, the westbound lane of the Tarouba Link road was also in a state of disrepair, and had been for awhile, so it may have been avoided by commuters. The San Fernando By-Pass is well designed to divert traffic east onto the Tarouba Link Road, making this an attractive option for drivers travelling towards the Solomon Hochoy Highway.

On Lady-Hailes Road, the highest numbers of maxi-taxis and buses were counted. This is expected as the San Fernando Bus Terminal is located beside the wharf area at the north end of Lady Hailes; the designated stand for these maxis is located adjacent to the Bus Terminal.



## 7. Key Stakeholder and Public Consultations

Public consultation is an integral part of the environmental assessment process. It provides the opportunity for interested stakeholders to receive information from the project design team and, in turn, allows the proponents to gain input about public concerns. Public consultation can also provide an opportunity to actively involve stakeholders in the early stages of a project which, in turn, delivers a sense of transparency in the assessment and planning process. Cooperation between the public, corporate and government sectors helps to determine and quantify the project impacts (both positive and negative), and to co-ordinate mitigation responses if needed.

For the San Fernando Wastewater project, liaison was made between AECOM, WASA and project key stakeholders in the form of a consultation meeting and separate introductory meetings for each agency. For this project, key stakeholders included utility agencies, government ministries, developers, and private businesses. Opportunities for public participation with residents of the San Fernando Wastewater Catchment Area were provided in the form of two open-house public consultations meetings as stipulated in the TOR of the CEC application. Door-to-door surveys were also conducted to provide feedback on the popularity of the project and to identify perceived attitudes and concerns associated with the project.

### 7.1 Requirements of CEC TOR

The TOR for obtaining a CEC for the San Fernando Wastewater Project was produced by the EMA for WASA to guide the development of an EIA and consequently this report. The TOR is attached in **Appendix A.1** and it gives details on the scope of the EIA.

The TOR identifies the need for key stakeholder and the public to “assist in the identification and mitigation of impacts while preventing environmentally unacceptable development, controversy, confrontation and delay.” It requires that the agencies most relevant to the project be identified and contacted to make their input to the project.

With respect to liaison with members of the public the TOR states that the consultation sessions should introduce and explain the project adequately as well as address all issues raised. Guidelines for conducting the consultations are also included; generally they should be held at a date, time and venue most convenient to the participants and should be advertised according to the standards given in the TOR. Any consultations held subsequent to the first session must address alternatives to the project and impacts that may have been identified.

For the San Fernando Wastewater project the following activities assisted in communication with the public and stakeholders:

- One meeting and presentation where all stakeholders were invited.
- Meetings with individual stakeholder groups.
- Two open house public consultation meetings.
- Door-to-door surveys.

This communication not only provided venues for AECOM and WASA to explain the project, it allowed for feedback from all persons on how the project will affect themselves and the organizations they are



representing. From these meetings, information was gathered that supplemented the design phase of the project. Negative impacts were attempted to be minimized to the extent possible. Door-to-door surveys are discussed in Section 6, and the meetings are listed in Table 7-1 below.

**Table 7-1 Schedule for Public Consultations and Stakeholder Meeting**

Meeting	Invitees	Venue	Date
Various Introductory Meetings with Key Stakeholders	Utilities, Ministers, Developers, Private Companies, Corporations	Various	Various
Key Stakeholder Meeting and Presentation	Industrial and Municipal Stakeholders; Utility Companies	WASA South Regional Office, St. James Street, San Fernando	September 30, 2009
Open House Public Consultation # 1	Public Citizens, Industrial and Municipal Stakeholders	San Fernando Central Secondary School (Modsec); Todd Street, Les Efforts West, San Fernando	January 26, 2010
Open House Public Consultation # 2	Public Citizens, Industrial and Municipal Stakeholders	Pleasantville Community Centre, Prince Albert Street, Pleasantville, San Fernando	April 13, 2010

The following sections are a description of the events listed above.

## 7.2 Introductory Meetings with Key Stakeholders

The San Fernando Wastewater Project was introduced to relevant stakeholders for the purpose of obtaining data pertinent to the treatment plant and collection system design. These agencies were also introduced to the project for the purpose of fulfilling the CEC TOR and facilitating coordination where proposed developments have the potential to conflict with the San Fernando Wastewater Project. These meetings were with individual groups and occurred mainly in the preliminary design stages of the project.

Table 7-2 lists the agencies that were contacted and the representatives present at the meetings with AECOM and in some cases WASA staff.

**Table 7-2 Introductory Meetings held with Relevant Agencies**

Agency	Representative(s)
Ministry of Works and Transport (MOWT)	Mr. Derek Bosland – Transport Division, Bridges Department
Gulf City Mall	Mr. Sanmook - Director
Petroleum Company of Trinidad and Tobago (Petrotrin)	Mr. Premchan Rambahrose – Penal Operations
Trinidad and Tobago Electricity Commission (T&TEC)	Mr. Farzard Nobbee – Utilization Department
Telecommunication Services of Trinidad and Tobago (TSTT)	Mr. Paul Gajar – Engineering Department
San Fernando City Corporation	Mr. Ramesh Sookdeo – City Engineer
Ministry of Planning, Housing and the Environment	Ms. Dixie Joseph – Land Settlement Agency (LSA) Ms. Sheryl-Anne Haynes – Director, TCPD Mrs. Shelley Sultanti-Maharaj – Assistant Co-ordinator, TCPD
Ministry of Local Government	Mr. Rodney Ramlogan – Regional Planning Unit Mr. Ewoud Heesterman – Interplan Consulting Group
PACE Construction Services Ltd	Mr. Francis- Site Engineer

### 7.3 Key Stakeholder Meeting

The Key Stakeholder meeting was held on September 30, 2009 to inform groups of the project, in order that cooperation could be obtained in gathering information relevant to the planning and design. The list of invitees was selected to include those groups who could be directly impacted by the proposed project. This list included utilities, developers, regional corporations, and government ministries. The full list of invitees and attendees is located in **Appendix F.1**. Information including utility as-built locations, future developments, and projects are critical to a successful wastewater project. This meeting also sought to determine the attitudes and expectations of stakeholders with respect to the project.

The presentation gave an overview of the project, and highlighted the importance of cooperation with stakeholders. A copy of this presentation is provided in **Appendix F.1**. A question and answer period followed as summarized in Table 7-3.

**Table 7-3 Questions and Answers from September 30, 2009 Meeting**

Concern Raised by Key Stakeholder	Answer by WASA and/or AECOM
Mr. Roger Parris (UDECOTT) - Concerns about individuals paying for connections to the new system. Most individuals will not pay to connect so the system will have low flow and the environmental problems will continue.	Ms. Denise Lee Sing Pereira (WASA) responded – WASA is planning to include service connections as a project cost.
Mr. Roger Parris (UDECOTT) - Concerns about as-built utility drawings and disrupting existing utilities with construction.	Mr. Jim Marx, and Mr. Matt McTaggart (AECOM) responded – AECOM has been trying for 6 months to obtain this information. It is disappointing that there are no utility representatives here today. AECOM continues to follow up.
Mr. Nigel Gopaul (CSO) - Curious about who was conducting social surveys.	Mr. Jim Marx (AECOM) responded – We have not finalized our sub-consultant yet. Ms. Kimlin Austin (WASA) responded – The social surveys are just a representative sample of the project area, it is not everyone that is being questioned.
Chris Mayhew (TriniTrain) – Rapid Rail needs to be aware of future developments so that all projects will be catered for, and there is no overlap.	Further discussion between AECOM and Mr. Mayhew after the meeting to exchange contact information.
(Ministry of Agriculture) – Project will have positive impact on fishing, and groundwater. Interested in uses of treated solid waste for agricultural application.	Sludge generated will be USEPA Regulation Class B solids, so there are options for agricultural application.

## 7.4 Public Consultations

These meetings were conducted to provide an opportunity for members of the public to learn more about the proposed project and to provide an opportunity for them to express their comments. In keeping with the TOR, two public consultations were held within the study area. From the interest of the public, comments received, and attendance numbers, it was determined that additional public consultations would not be necessary.

### 7.4.1 Public Consultation # 1

The first public consultation was held on Tuesday January 26<sup>th</sup> 2010 at San Fernando Central Secondary School (MODSEC) at 5:30 pm. Advertising was conducted through flyer distribution to businesses and the public in the project area, and advertising in the Daily Express® Newspaper on January 19<sup>th</sup>, 2010. Letter invitations were delivered to key stakeholders, members of government, utilities, and non-governmental organizations.



A formal PowerPoint presentation included:

- Introduction and purpose of the meeting.
- Project background.
- Overview of the design of Collection System and WWTP.
- EIA baseline sampling data conducted to date.
- Plan for completion of the EIA.

Time was allocated for answering questions, and receiving comments on the proposed project. Key questions and comments raised, and responses have been included in Table 7-4. Information on the public consultation including meeting notes, a copy of the presentation, flyer, a list of invitations, the PowerPoint presentation, and meeting notes are all located in **Appendix F.2**.

Thirty-four people attended the consultation, not including WASA staff, presenters or organizers.

**Table 7-4 Key Questions and Answers from January 26, 2010 Meeting**

Concern or Question Raised by Key Stakeholder	Answer by WASA and/or AECOM
Where does the water go after it is treated?	At the beginning of the project this was not in the scope of works, and discharge was to the Ciperio River. Once the project got underway, WASA asked that the possibility of treating the wastewater to reuse standards be examined as well. The design of the WWTP will now treat the wastewater to reuse standards through UV and filtration, in case WASA would like to use it for alternate uses.
As an officer of Public Health, we have issues all of the time with lift stations. They smell and it is a health hazard, especially the one at Pleasantville. When will these lift stations, especially this one, be phased out?	We know which lift station you are talking about. It is loud and it smells because it is so open. In the design, this lift station will be eliminated. Our design will be completed in July 2010, and from there WASA will need to secure funds for construction. We are unsure of how long this may take.
We have developments within your catchment area, Pleasantville, Retrench, Tarodale, etc. that all have their own wastewater treatment facilities. How will our HDC facilities be engineered into this new collection system?	AECOM has had meetings with ministers responsible for future development in the area, as well as determining the new housing developments which are sewered and have wastewater treatment plants. The HDC developments in the project area will be tied into the new collection system.
What provisions are there for Earthquakes?	All of the designs are conducted in accordance with the appropriate earthquake codes for Trinidad and Tobago.
Has the cost been considered? Or the least cost situation?	We are designing with cost in mind. The wastewater treatment plant is being built with high efficiency blowers and the plant hydraulics will be designed to minimize pumping, which will decrease the operation costs. Minimizing lift stations will decrease the operation costs because pumps will not be required and overall maintenance to the lift stations.



**Table 7-4 Key Questions and Answers from January 26, 2010 Meeting (continued)**

Concern or Question Raised by Key Stakeholder	Answer by WASA and/or AECOM
What tertiary treatment of effluent is occurring?	The tertiary treatment that will occur at the WWTP includes UV disinfection, and cloth filters.
Will collection system construction take into account material construction that will not break?	Yes, especially the areas where trenchless technology will be used. When the trenchless technology is used, the material required to withstand the jacking forces during installation means that the pipes have to be very strong. The likelihood of these pipes leaking is minimal.
Will more land space be required?	The wastewater treatment plant will be constructed at the existing San Fernando wastewater treatment plant, so additional land will not be required. A staging area during construction may be required, but land across the Ciperro River, where the Gulf View wastewater treatment plant is located could be used. This land is also owned by WASA, so no additional land would be required. During construction of the collection system, land easements will be required, but these are construction easements only.
Will soak-aways be tied into this new collection system?	Yes the houses with soak-aways will be connected to the new collection system. This will need to be studied on a case-by-case basis.
Will this project consider connections to existing systems in the project area, and repairs to existing systems?	Yes, all existing sewers within the project area will be integrated into the collection system. A CCTV program is currently underway to look for existing damaged pipes, and to replace those pipes under this project.

#### 7.4.2 Public Consultation # 2

The second public consultation was held on Tuesday April 13<sup>th</sup> 2010 at the Pleasantville Community Centre at 5:30 pm. Advertising was conducted through flyer distribution to businesses and the public in the project area, and advertising in the Daily Express Newspaper on April 7<sup>th</sup>, 2010. Letter invitations were delivered to key stakeholders, members of government, utilities, and non-governmental organizations. Anyone who attended Public Consultation #1 and left an email address was personally contacted through email.

A formal PowerPoint® presentation included:

- Detailed design of the collection system and WWTP.
- Updates in the design from Consultation #1.
- Results from the EIA baseline sampling.
- Impacts of the project.
- Mitigation measures during construction and operation phase.

Time was allocated for answering questions, and receiving comments on the proposed project. Key questions and comments raised, and responses have been included in Table 7-5. Information on the



public consultation including meeting notes, a copy of the presentation, flyer, a list of invitations, the PowerPoint presentation, and meeting notes are all located in **Appendix F.3**.

**Table 7-5 Key Questions and Answers from April 13, 2010 Meeting**

Concern or Question Raised by Key Stakeholder	Answer by WASA and/or AECOM
<p>What about the systems that do not function properly? Will these systems be fixed? Example; the Pleasantville Lift Station which emits bad odour and Orchid Garden Lift Station that discharges wastewater into the surrounding drainage system</p>	<p>The Pleasantville Lift Station would be eliminated and all existing infrastructure would be incorporated into the new San Fernando Wastewater Collection System Design.</p>
<p>How soon will the existing wastewater infrastructure be eliminated?</p>	<p>There is no quick fix for wastewater systems since it must be sustainable and therefore a long-term solution has to be employed. If a short-term resolution is used then the problem would recur. WASA acknowledges that their infrastructure has not kept pace with housing development in San Fernando. The SFWWTP would be functioning throughout construction of the Collection System. The San Fernando Catchment Area would be divided into phases for sewer installation so that priority areas would be serviced first.</p>
<p>Would co-ordination between water and sewer installation take place?</p>	<p>Co-ordination between agencies would take place before construction commences so that sewer and water pipes would be laid simultaneously.</p>
<p>The roadways are constantly disrupted and all utilities fall under the same Government Ministry so co-ordination should be better.</p>	<p>Concern will be taken into consideration.</p>
<p>Road repair is only done on the side of the road where the trench is located and the other side of the road becomes dilapidated because of heavy traffic flow. This needs to be taken into account during tender document preparation.</p>	<p>Traffic management plan would be included in tender documents to ensure this concern is addressed. Personnel from AECOM and WASA would supervise the work and ensure Contractor carries out according to the tender documents.</p>
<p>The detour roads that are utilised when traffic is diverted are not capable of traffic loads. The detour roads are damaged in the process and are never repaired.</p>	<p>This would be considered when formulating the traffic management plan for the tender documents.</p>

**Table 7-5 Key Questions and Answers from April 13, 2010 Meeting (continued)**

Concern or Question Raised by Key Stakeholder	Answer by WASA and/or AECOM
Are the sewers routed according to low points?	Yes, some of the sewer routes are proposed along the rivers and in certain areas trenchless technology would be used.
Resident lives alongside a major drain in Phillipine/Duncan Village which is need of repair and inquired if this drain would be fixed when sewers are layed.	The project does not entail repairing all drains in the project area but if the sewer is proposed in the area when it is installed the drain would be fixed in the process.
Who will give final approval when determining priority of subcatchments to be sewerred? Would it be Consultant or Ministerial Committee?	AECOM is recommending which areas would benefit most from sewer installation. The Client, WASA would make the final decision.
Will the new San Fernando WWTP be operational before the Collection System?	AECOM plans to tender the new WWTP and Collection System simultaneously. Therefore a trunk sewer can be layed to connect areas that are already sewerred to the new WWTP. These areas would have the most beneficial cost for construction.
Is the new WWTP designed to accommodate existing development or proposed development?	The new San Fernando WWTP will encompass new development and projected population. Satellite photos were used to determine and project the increase in population. Flows projected to 2035 and based on a population growth where all unused land in the San Fernando area would be developed.

The questions and concerns raised in the second public consultation were addressed during the meeting, however, any further clarification needed should be provided in this report. After the second public consultation one of the residents emailed further questions about the San Fernando Wastewater Project. These questions and responses are included in **Appendix F.3**.

## 7.5 Conclusion

The perceived notions and attitudes of the public towards the project are generally positive. The residents and stakeholders realise that the project would be beneficial to the environment and their main concerns were about:

- Effluent and treatment
- Malfunctioning systems
- Areas to be sewerred
- Project cost
- Project schedule
- Roads



The questions of the persons attending the liaison meetings were addressed in the sessions; however, the report seeks to address any issues that may not have been clarified. The social survey conducted to fulfil the TOR for the CEC application of the San Fernando Wastewater Project also sought to identify the perceptions and attitudes of the residents. The findings of this evaluation were discussed in Section 6 and are used in addition to the public consultations to determine the impact of this project on the lives of the residents and business population within the project area.



## 8. Impact Analysis and Mitigation Measures

The EIA process provides a formalized procedure for obtaining project specific, local environment, and social information to evaluate the anticipated or probable environmental consequences of conducting a specific project activity.

This Section presents the methodology for the identification of project-environment interactions, a review of predicted project impacts, and an evaluation of these impacts. The objective of this analysis is the identification of significant aspects and impacts which will require appropriate mitigation and/or future monitoring.

### 8.1 Methodology

#### 8.1.1 Impacts Assessment

An impact is any change in an environmental parameter both social and physical due to a particular activity or event. Evaluation of environmental and social impacts involves the following steps:

- Description of project activities
- Description of environmental attributes
- Identification of project-environment interactions
- Prediction of environmental effects
- Description of environmental effects

The project activities were described in Section 3 of this EIA Report including decommissioning activities of the existing wastewater infrastructure. The environmental and social attributes that may be affected as a result of this project were discussed in Sections 5 and 6 respectively. Potential environmental impacts were identified by superimposing project elements onto existing natural conditions. An underlying assumption is that the San Fernando Wastewater Project will be constructed with due care for safety and environmental matters, using current and reasonable engineering practices.

The impacts were assessed based on the nature of the effect, magnitude, spatial extent, duration, project phase and the degree of reversibility. Various terms have been used to identify and describe the potential impacts assessed. Table 8-1 provides an explanation of these terms.



**Table 8-1 Explanation of Terms Used in Impact Assessment**

<b>Project Phase:</b>	Refers to the phase of the project as construction, operation or decommissioning of the existing wastewater facilities.				
<b>Potential Impact:</b>	Classification of the type of impacts anticipated during a specific project phase. This includes: soil quality, air quality, water quality, flora and fauna populations, transport and social environment.				
<b>Magnitude of Impact:</b>	<p>Refers to the estimated percentage of population or resource that may be affected by activities associated with the construction, operation and decommissioning of the proposed WWTP and collection system. Where possible and practical, the population or resource base has been defined in quantitative or ordinal terms (e.g., hectares of soil types, units of habitat). Impact magnitude has been classified as less than (&lt;) 1%, 1 to 10%, or greater than (&gt;) 10% of the population, or resource base.</p> <p>Where the magnitude of an impact has been defined as virtually immeasurable and represents a non-significant change from background in the population or resource, the impact is considered negligible. An exception to this is in terms of potential human health impacts where for example, deaths due to waterborne disease amounting to 1% of the population would still be considered major.</p>				
<b>Direction of Impact:</b>	Refers to whether an impact to a population or a resource is considered to have a positive, negative or neutral effect.				
<b>Duration of Impact:</b>	Refers to the time it takes a population or resource to recover from the impact. If quantitative information was lacking, duration was identified as short-term (<1 year), medium term (1 to 10 years) and long term (>10 years).				
<b>Frequency of Impact:</b>	Refers to the number of times an activity occurs over the project phase, and is identified as once, rare, intermittent, or continuous.				
<b>Scope of Impact:</b>	Refers to the geographical area potentially affected by the impact and was rated as local, regional, or national. Where possible, quantitative estimates of the resource affected by the impact were provided.				
<b>Degree of Reversibility:</b>	Refers to the extent an adverse impact is reversible or irreversible over a 10-year period.				
<b>Residual Impact:</b>	A subjective estimate of the residual impact remaining after employing mitigation measures in reducing the magnitude and/or the duration of the identified impacts on the environment.				
<b>Magnitude of Impact</b>	<b>Direction of Impact</b>	<b>Duration of Impact</b>	<b>Frequency of Impact</b>	<b>Scope of Impact</b>	<b>Degree of Reversibility of Impact</b>
Negligible (immeasurable)	Positive	Short term (< 1 year)	Once	Local	Reversible
Minor (<1%)	Negative	Medium (1 to 10 years)	Rare	Regional	Irreversible
Moderate (1 to 10%)	Neutral	Long term (>10 years)	Intermittent	National	
Major (>10%)			Continuous		



The evaluation of impacts should address, at a minimum, the following components which are anticipated to be affected by the proposed construction and operating activities:

- Air quality
- Water quality
- Soil quality
- Flora and Fauna
- Human Environment (social, health and economic impacts)

The potential impacts on specific environmental parameters should be described in terms of relative or absolute significance, where possible. Impacts are defined as negligible, minor, moderate or major according to the terms in Table 8-1.

### 8.1.2 Mitigation Measures

Mitigation measures are used to avoid, limit and control the impacts to the biophysical and social environment. Mitigation measures not already included in the design of the San Fernando Wastewater project will be provided to contractors and operations personnel for implementation during the construction and operational phases of the project. The mitigation measures proposed will be used as an alternative to enhance the biophysical and social benefits of the project. The residual impact remaining after implementation of mitigation measures will also be determined as part of the EIA. Where impacts are determined to be negligible, no mitigation is required.

All project impacts and mitigations are discussed in Sections 8.3 through 8.10 with a summary in Section 8.11. Table 8-4 displays all project impacts and mitigation measures.

## 8.2 Project- Environment Interactions

Identifying the interactions between the project and the environment leads to the determination of the potential environmental effects on the project. Section 3 presents a description of the project, and from this description the interactions with the environment can be determined.

An environmental interaction is any element of a facility's activities, products, operations or services which can or will interact with the environment. These interactions and their effects may be continuous in nature, occur periodically, or may be associated with specific events, such as emergencies. Some interactions may be beneficial, such as a reduction in odours; however the primary objective of this EIA study is to identify and minimize the negative impacts.

Based on an understanding of the proposed project and the sequence of project activities, the following project-environment interactions were determined (Table 8-2). This list is not comprehensive but presents the key likely impacts occurring in the construction, operation, and decommissioning stages of the project.



**Table 8-2 Project-Environment Interaction with Affected Environment**

Project-Environment Interaction	Affected Environment						
	Water	Air	Soil	Biological	Traffic	Other Social	
Storage/staging and stockpiling of materials, and chemicals C,O	x	x	x		x	x	
Obtain easements <sup>C</sup>						x	
Use of labour <sup>C,O</sup>						x	
Transportation to and from site (personnel, equipment, machinery) <sup>C,O</sup>		x			x		
Use of construction equipment and machinery <sup>C</sup>		x	x	x		x	
Use of lighting <sup>C,O</sup>				x		x	
Storage and disposal of construction debris and waste <sup>C</sup>	x				x	x	
Use of chemicals, coatings and paint <sup>C,O</sup>		x					
Ground excavation, vegetation clearing, ground compaction, trenching, piling <sup>C</sup>	x	x	x	x	x		
Alteration of grade and drainage patterns <sup>C</sup>	x		x				
Construction of WWTP <sup>C</sup>	x	x	x				
Construction Collection System Sewer <sup>C</sup>	x	x	x		x		
Water supply management <sup>O</sup>	x						
Effluent release to catchments <sup>C,O</sup>	x			x		x	
WWTP Equipment operation <sup>O</sup>		x					
Sludge Management <sup>C,O</sup>		x	x		x		
Odour Management <sup>C,O</sup>		x					

Note: C = construction phase; O = operation phase





## 8.3 Air Quality Impacts and Mitigation

### 8.3.1 Construction Phase

During the construction phase of the project, as described in Section 3, a new WWTP and eight lift stations would be constructed, the existing facilities would be decommissioned and the sewer pipes would be installed. The impact to air quality is addressed in terms of exhaust emissions, generation of airborne particles and dust and release of odours. The mitigation measures intended are also identified in this section based on the characteristics of the impacts.

#### 8.3.1.1 Exhaust Emissions

There exists potential for negative air quality impacts due to emissions from construction equipment operating on-site during construction and decommissioning activities, as well as vehicle transportation to the site. It is estimated there will be 50 vehicles or less at any one time at the WWTP site during the construction process, including worker vehicles and heavy equipment. As shown in Section 5.2.1, the wind is generally north easterly, which will likely provide some mitigation of exhaust emission effects as exhaust will be dispersed into undeveloped areas, and over the Gulf of Paria.

Unmitigated vehicle and equipment exhaust emissions are anticipated to result in a minor decrease in air quality on the site and a negligible decrease in air quality off the site.

Mitigation measures could include:

- Encouraging all workers not to idle vehicles.
- Carpool to site.
- Perform vehicle inspections regularly and maintain equipment.

Post mitigation, the residual impact will be minor on site, and negligible off site. These negative impacts will be of medium term duration, potentially occurring on a continuous basis during working hours of the construction period on a local scale and are considered reversible.

#### 8.3.1.2 Airborne Particles and Dust

Potential impacts to air quality may be caused due to generation of airborne particles and dust during construction and decommissioning activities of the WWTP and lift stations from:

- Vehicle movement along site roads.
- Earthworks.
- Storage and stockpiling of materials.
- Demolition activities, inclusive of de-sludging the existing drying beds.

Dust and airborne particles will increase when vehicles move along the unpaved site roads, especially during the dry seasons. During construction of the collection system, the earthworks undertaken would generate airborne particles and dust especially from excavation and the demolition of decommissioned facilities. Dust has the potential to negatively impact air quality with subsequent potential impacts to human health and flora (dust deposition).



Unmitigated impacts to air quality due to airborne particulates and dust will be negative and minor in magnitude.

Mitigation measures could include:

- Dust suppression activities such as watering roadways and exposed ground.
- Minimizing the amount of disturbed area.
- Backfill exposed construction site as soon as possible.
- Limit height of stockpiles on topsoil and to 2m height.

Post Mitigation, the residual impact will be minor on site and negligible off site. These negative impacts will be of medium term duration occurring intermittently during the construction period on a local scale. Impacts due to airborne dust and particles are considered reversible.

### 8.3.1.3 Odours

During the construction period, there will be potential for odour generation due to:

- Use of chemicals such as paint, asphalt, adhesives and solvents.
- Removal of sludge from existing drying beds and the area west of the drying beds.
- Use of a new septage receiving station during construction.

Chemicals used during construction may emit odours especially in areas that are sheltered or not well-ventilated. The odour emanated can have a direct impact to human health if used in enclosed spaces.

At the existing San Fernando WWTP, the closest residents to site to the sludge drying beds, and the area west of the sludge drying beds are located approximately 55 m north-west of the site to be excavated. As shown in Section 5.2.1, the wind direction is generally north easterly, causing the exhaust to disperse into undeveloped areas south west of the Site, and over the Gulf of Paria. There is also an existing drain with trees and underbrush on either side of the drain between the drying beds and these residences. The trees and underbrush may provide some dispersion or masking of odours. Although some odour impacts to the nearest residences may occur during the de-sludging process, the excavation activity will be limited to approximately 2 weeks or less during the construction phase, therefore limiting the extent of potential impacts.

The new septage receiving station will be built on the south-eastern end of the WWTP site, close to the Riverside Drive entrance, to maintain accessibility for septage trucks to continue to dispose of the septage throughout the construction phase. The closest residents to the proposed WWTP are located directly east of the WWTP site, approximately 25 m away from the new septage receiving station location.

The unmitigated impacts from these activities will be minor to moderate in magnitude, on a local scale.

Mitigation measures proposed include:

- Use of chemicals
  - Limit use to a well-ventilated area.



- Ensure OSHA rules are followed.
- Provide masks for staff working with chemicals that release a strong odour.
- Sludge Drying Bed excavation:
  - Conduct excavation when wind is directed predominantly to the southwest.
  - Utilize dust suppression activities.
- Septage Receiving Station:
  - Activated carbon filter odour suppression equipment, (Section 3.9.2).
  - Physical barrier wall to be built between septage receiving facility and residents directly east.
  - Complete decommissioning activities promptly to limit the odour generated that can affect employees and residents.

Post-mitigation, the impact will be negligible, during the construction period, on a local scale. Frequency will range from intermittent for the chemicals and sludge excavation to continuous for the septage receiving station.

### 8.3.2 Operation Phase

The operation phase of the San Fernando Wastewater Project as addressed in this section deals with mainly the proposed WWTP, proposed lift stations and new sewer pipes installed as part of the project. The effects of these activities on air quality are described below.

#### 8.3.2.1 Exhaust Emissions

During the operational phase, there will be traffic accessing the WWTP site for delivery of materials and chemicals, biosolids removal, septage receiving, and worker vehicle traffic. These proposed traffic volumes represent an overall reduction compared to the current operation of the WWTP as seen in Table 8-3.

**Table 8-3 Weekly Anticipated Traffic at San Fernando WWTP Site During Operation**

Site Traffic	Current WWTP	New WWTP
Material delivery	1	1
Biosolids removal	0	25
Septage Receiving	68	54
Worker traffic	137	70
<b>Total</b>	<b>206</b>	<b>150</b>

This decrease to traffic results in a relative positive impact to the exhaust emission generated. No mitigation measures are required.



### 8.3.2.2 Airborne Particles and Dust

The current operation of the WWTP uses sludge drying beds that generate airborne particles and dust on an intermittent basis during clean-out activities. With the proposed design, there is potential for the generation of airborne particulates and dust during the operational phase of the project due to:

- Traffic movement on the WWTP site.
- Water aerosol generation from the bioreactors.

This would result in a negative minor impact.

Mitigation measures proposed include:

- Replacing the sludge drying beds with DAF thickening, aerobic digestion, and a belt filter press to dewater the sludge (See Section 3 for a complete description). DAF thickening and aerobic digestion may produce water aerosol, however, tank freeboard will contain these aerosols.
- Paving the roads of the WWTP site.
- The design of the bioreactor was chosen as fine bubble aeration which produces fewer aerosols and is quieter than mechanical surface aeration. The design has also incorporated additional tank freeboards to contain the aerosols.

With the incorporation of these mitigation measures in the design the post-mitigation impact is expected to be negligible and local in scale over the long term (for the life of the WWTP facility).

### 8.3.2.3 Odours

Treatment at the existing WWTP generates odours, mainly due to:

- Septage Receiving Station – This is an open-air process that uses aeration. Significant odours are generated at this step. Screenings are piled beside the station and intermittently buried or trucked off-site.
- Grit Removal Chambers – The screenings and grit from this process are piled beside the chambers on the ground, and intermittently buried or trucked off site.
- Trickling filter ponding – Due to the maintenance issues and age of this process step, the two trickling filters, located on the south side of the site, 40m away from the closest resident, generate odours.
- Anaerobic digesters – Anaerobic digestion causes the release of hydrogen sulphide, a gas associated with a “rotten egg” smell. These two digesters, located 15 m away from the property line of residents, are not fully operational, so additional odours are being generated.

When the above factors combine, there are reportedly significant odours that are generated at the current WWTP.

The proposed WWTP design could have the potential for operational odour generation due to:

- Storage of screenings, grit and biosolids prior to disposal.
- Collection of septage on the site.



During the screening and grit removal stages of the proposed wastewater treatment process, compacted screenings, and dewatered grit will be discharged to a dumpster for storage before being hauled off-site for disposal. This has the potential to result in the release of odours in the dumpster area. The odours would be expected to exist on a local scale in the area immediately surrounding the dumpster area.

The new septage receiving station will be built on the south-eastern end of the WWTP site, close to the Riverside Drive entrance, to maintain accessibility for septage trucks to continue to dispose of the septage throughout the construction phase. The closest residents are located directly east of the WWTP site, approximately 25 m away from the proposed septage receiving station. This could result in a negative odour which, if un-mitigated, could extend to the residents' home.

Mitigation measures to address odour control have been incorporated into the design of the proposed WWTP to address these impacts, as well as the current issues at the existing San Fernando WWTP. These include:

- Storage of screenings and grit in closed containers (dumpsters) instead of on the ground.
- Ensuring all waste is hauled off-site on a scheduled and timely basis.
- Construction of a contained septage receiving station, with odour control.
- Maintaining odour suppression equipment, through regular carbon filter replacement.
- Decommissioning the existing trickling filters.
- Conversion of anaerobic digesters to aerobic digesters. Hydrogen sulphide is not generated as a by-product gas of this process.

Post-mitigation, there are still opportunities for odours to be generated at the proposed WWTP site; however the mitigation measures proposed are anticipated to result in a relative positive impact compared to the current WWTP operation. Odours generated at the proposed WWTP site are expected to disperse sufficiently on site so as not to cause noticeable effects on nearby residents. Odour generation will be negligible, and should not be noticed by residents.

## 8.4 Noise Impacts and Mitigation

### 8.4.1 Construction Phase

Noise and vibration will be generated to varying degrees during construction activities and have the potential to influence people in the surrounding area and local fauna. Construction noises may be expected to arise from the use and arrival of heavy equipment at the site, increased traffic, and associated construction noise. The construction phase noise is expected to be typical of heavy equipment such as trucks and backhoes, which will occur at both the existing WWTP site, as well as the locations of the collection system construction. Noise from tools, such as hammers, is expected throughout the construction phase At the WWTP site; piles will be driven intermittently throughout the first 8 months of construction.

Impacts due to construction noise will be negative and minor to moderate in magnitude.

Mitigation measures proposed include:

- Maintain vehicles and equipment.



- Keep idling of vehicles to a minimum.
- Construction activities limited to daytime hours when possible.

Residential homes neighbour the WWTP site to the north and east, and will be beside most of the collection system construction. Typically residents are not home during the weekdays. Attempting to have construction activities during daytime hours will greatly mitigate impacts due to noise in the local area. Post-mitigation, the impacts will be minor to moderate and intermittent over the short term during construction on a local scale.

#### 8.4.2 Operational Phase

During operation, noise will be generated from wastewater processes and equipment including pumps and blowers. This equipment is proposed to run continually 24/7, and has the potential to generate considerable noise. Unmitigated, this noise would affect the surrounding residents, and workers at the site. The impact would affect a minor portion of the project area population, however due to the impact that this noise would have on this population, the impact is classified as moderate.

The measures proposed in the design mitigate against the potential operational impacts of noise generation from the WWTP and lift station operations by:

- Placing pumps in enclosed buildings to minimize the amount of noise generated.
- Proposing a fine bubble aeration system that would be quieter than a surface aeration system for the bioreactor.
- Including acoustic enclosures to minimize blower noise.
- Properly maintaining and servicing equipment so that it runs properly and keeps noise to a minimum.

With these mitigation measures incorporated into the proposed design, the residual impacts are expected to be negligible off-site. This would be continuous for the long term.

### 8.5 Water Impacts and Mitigation

#### 8.5.1 Construction Phase

During the construction phase the potential exists for water quality in the project area to be affected. Runoff from construction sites, altered drainage patterns, spilled fuels and paints, or untreated wastewater or sludge entering watercourses have the potential to occur. The project design has included measures to reduce these occurrences.

##### 8.5.1.1 Land Clearing, Excavation and Storage Along Watercourses

During construction land will be cleared and excavated, which increases the potential for sedimentation as a result of:

- Soil erosion
- Possible changes to grade and drainage
- Storage of materials from stockpiles being washed into waterways



Silt runoff and sedimentation impacts resulting from construction activities associated with the collection system, lift stations and WWTP are expected to last until reforestation of the site or at exposed areas is completed or until the stream beds and banks are stabilised after construction. A possible impact is the transport of sediment away from the construction site. Depending on the original clarity of the watercourse, the flow velocity, and the column of silt that is entrained, this impact may be noticeable more than 100 m downstream of the construction site.

To mitigate this impact the following measures are proposed:

- The design of the WWTP and collection system requires that all water entering waterways from the site must have a TSS of less than 30 mg/L. An erosion control plan (**Appendix G.1**) has been developed which includes erosion control measures and bank stabilization that will assist with meeting this requirement.
- Dumping of excavated fill, waste material or debris into waterways will not be permitted.
- Stockpiles will not be located next to waterways.
- Drainage works will be constructed in accordance with the requirements of the Ministry of Works and Transport – Drainage Division.
- The contractor must submit a construction plan to WASA for approval before work in and around watercourses can occur.
- Changes from existing grading of the WWTP site will be minimized to the extent practical to minimize soil disturbance.

Post mitigation, sedimentation will be negligible.

#### *8.5.1.2 Release of Untreated Wastewater from San Fernando WWTP*

During construction of the new WWTP, the potential for release of untreated wastewater from the San Fernando WWTP and temporary sanitation facilities into the environment is a possibility, as the current equipment at the WWTP site will need to be demolished for the new equipment to be constructed. Total system bypass of the WWTP into the Ciperó River would negatively affect the Ciperó River quality over the 2 year WWTP construction period, resulting in a continuous negative impact on a local to regional scale. Although the Ciperó River water quality results already show results indicative of raw wastewater being discharged to the river, this impact would be major due to the flows to WWTP.

This would also negatively affect the existing catfish population in the area, potentially disrupting fishing activities in the Gulf of Paria close to the Ciperó River.

Accordingly, the proposed design includes construction sequencing to ensure that the WWTP remains operational throughout the entire construction period. This sequencing will allow the contents of temporary sanitation facilities to be disposed of at the septage receiving station at the WWTP site in a largely uninterrupted manner.

As the construction progresses and the new WWTP are brought online to treat wastewater an improvement in the treated effluent quality released to the Ciperó River will occur. Post-mitigation, the impact of release of untreated wastewater from the San Fernando WWTP entering the environment is negligible. This impact would occur over the construction period on a continuous scale on a local to regional scale.



## 8.5.2 Operation Phase

### 8.5.2.1 Release of Untreated Wastewater from San Fernando WWTP

Once fully constructed, all wastewater will be directed to the San Fernando WWTP. If untreated wastewater is discharged to the Ciperó River, the impact of discharging untreated wastewater to the Ciperó River would be major in magnitude.

In order to mitigate against the discharge of untreated wastewater, the design includes redundancy in a number of the WWTP processes in the event of mechanical failure. Section 3 details the redundancies, which include additional pumps and blowers, filters and UV equipment, and one additional fine screen station. With these redundancies in place, the likelihood of the WWTP having to be bypassed would be rare.

During extreme wet weather events, the impact of plant bypass has been mitigated through the design of storm water storage tanks. The tanks can hold up to 50 minutes of storage during the peak instantaneous flow to the WWTP of 158 ML/d. This storage volume is expected to contain all storms considering that the majority of the collection system will be new and I&I should be minimized. Once the storm event has subsided, the contents of the storage tanks would be gradually returned to the headworks by gravity.

With these mitigation measures incorporated, the residual impact of the proposed WWTP releasing untreated wastewater becomes negligible.

### 8.5.2.2 Water Quality Improvement

The operation of the proposed WWTP, when fully constructed, is expected to have a major positive effect on the San Fernando Project regional area water quality. This will be a long term, continuous impact. As indicated in Section 5, the water quality data from the monitored rivers within the project area indicate that untreated wastewater is currently entering the watercourses. The project, when fully constructed, will divert all untreated wastewater within the project boundaries to the new WWTP for treatment and disposal to meet the EMA Water Pollution Rules 2001 (as amended). Although some water samples upstream of the catchment did not meet the EMA Water Pollution Rules 2001 (as amended) First Schedule guidelines, there will be a major improvement to water quality when the untreated wastewater is diverted to the new WWTP for treatment and discharge.

### 8.5.2.3 Potable Water Use

During the operational phase of the WWTP, approximately 1.5m<sup>3</sup>/day of WASA supplied water will be required for domestic consumption, lab work, sinks and service water. Treated effluent, with sodium hypochlorite added, will be used for landscape watering, tank washing and line purging, which is expected to be approximately 2.0m<sup>3</sup>/day (Section 3.9).

The current San Fernando WWTP does not reuse treated effluent, and uses potable WASA supplied water for all applications. The current WWTP is on an unmetered service, so it is unknown the exact amount of water that is used at the site; however the use of WASA supplied potable water is expected to decrease at the new WWTP due to the treated effluent reuse. This results in a positive impact to potable water use.





## 8.6 Soil and Land Impacts and Mitigation

### 8.6.1 Construction Phase

#### 8.6.1.1 Erosion

During the construction period, one of the impacts that will occur is the disruption to the surface area and roads due to excavation of the roads and other surface areas. These activities are essential for installation of the collection system pipes, all underground utilities and below grade structures that are necessary for the operations of the WWTP and collection system. In open trench collection system construction, the minimum width of trenches will be:

- Pipe diameter + 3.0m for major thoroughfares and paved collector roads.
- Pipe diameter + 1.5m for secondary paved or surface treated roads and gravel roads.

Backfill material and salvaged topsoil will be temporarily stockpiled for use in the construction and re-vegetation process. Erosive action on these stockpiles and disturbed areas due to heavy precipitation and winds can result in the loss of soil resource, runoff to surface watercourses, and potential impacts to aquatic resources.

If there were open excavation during a heavy rainfall, the unmitigated negative impact could be moderate in magnitude, occurring intermittently on a regional scale.

Proposed mitigation measures include:

- Development of an erosion control specification, to be implemented by the Contractor and enforced by WASA (**Appendix G.1**).
- Construction sequencing of work, to minimize the amount of exposed sites, as detailed in Section 3.12.
- Cover or backfill trenches as soon as possible.
- Locate stockpiles away from watercourses, and minimize the amount of material stockpiled on site.

With mitigation, erosion impacts to soils during the construction phase are anticipated to be negative, negligible to minor in magnitude and to occur intermittently over the short term on a local scale.

#### 8.6.1.2 Compaction

During the construction phase, construction at the WWTP site, and collection system construction may result in soil compaction from:

- Construction equipment and machinery.
- Storage and stockpiling of materials.

This would result in a minor negative impact at the construction site and stockpile area.

Mitigation measures will include:

- Level sites and fill (if required) to restore to pre-construction grades.



Post-mitigation, this will result in a negligible impact. This will occur on a local scope intermittently throughout construction.

### 8.6.1.3 Sludge Management

Current operations of the WWTP include burying screenings, grit and sludge in localized areas on-site. This resulted in a negative impact to the soil at the WWTP site, as this solid waste should have been properly disposed of in a landfill.

To mitigate this, during construction, the existing sludge, grit and screenings at the WWTP will be removed from the sludge drying beds, and excavated from other areas at the site where these materials were previously buried. This sludge will be transported off-site to a landfill. The closest landfill is the Forres Park Landfill in Claxton Bay which is operated by the Solid Waste Management Company Limited (SWMCOL). Clean fill will replace these excavated sites. This will be a positive impact to the soil on a local scale.

### 8.6.2 Operation Phase Erosion

During the operational phase, there is potential for erosive action on soils at the effluent discharge location. Erosive action can result in soil loss and potential subsequent impacts to surface water and aquatic resources. If not properly designed this could be a moderate negative impact.

Mitigation will include designing the outfall with erosion protection. This includes the use of riprap or concrete to line the outfall channel.

Post-mitigation, the impact will be considered negligible, on a local scale, and continuous over the life of the WWTP.

## 8.7 Biological Impacts and Mitigation

### 8.7.1 Construction Phase: Flora

#### 8.7.1.1 Species Loss

During the construction phase of the proposed project, there is potential for flora species loss due to:

- Ground disturbance.
- Soil compaction from heavy equipment use.
- Clearing activities at the WWTP.
- Off-road collection system installation.

Soil compaction from construction machinery, clearing and grubbing and the general disturbance of the site will potentially negatively impact vegetation in the immediate area of the construction activities.

Approximately 350 m<sup>2</sup> of land located west of the existing WWTP fence line will be utilized for the proposed WWTP. This site is currently used to bury septage that will have to be removed and is overgrown with grasses and small bushes that will need to be removed up to the edge of the new fence line. Additional lands will also be disturbed during the collection system construction in off-road areas. Lift stations will need to be constructed, on existing WWTP and lift station sites, or new areas. Some



flora species will also be lost due to the placement of riprap or concrete at the effluent outfall location. Preservation of mangrove woodland, riparian forest and silk cotton trees is highly recommended (Comeau, 2010).

The magnitude of the negative impact could range from minor to major, and duration could be short or long term dependant on the type of vegetation that is removed.

Mitigation measures proposed include avoiding the mangrove woodland, silk cotton trees, and riparian forest to all extent possible, and containing fuel and chemical spills (Section 8.12). As indicated in Section 5, the flora observed in the project area includes low vegetation with scrub and agriculture.

- Silk cotton trees and mangrove woodland are not located on the WWTP site, although there are a few trees and bush on the northwest portion of the site that may classify as riparian. These trees will be preserved to all extent possible.
- Design of the collection system in off-road locations and lift station sites will avoid the silk cotton trees and mangrove woodland, but may disturb some riparian forest. Trenchless technology will be utilized to minimize the amount of disturbed riparian forest. Any disturbed forest will be re-established once construction is complete.

With mitigation measures, the impact due to flora species loss from construction activities is considered negligible to minor. This negative impact is on a local scale and will occur once per site on a short term basis. The predicted residual impact is reversible.

#### 8.7.1.2 *Dust Deposition*

During construction there is potential for impacts to flora due to dust deposition. Construction and decommissioning activities have the potential to generate fugitive dust emissions. Unmitigated impacts to flora due to airborne dust and particulates will be minor to negligible in magnitude.

Mitigation measures include:

- Dust suppression activities such as watering roadways and exposed ground.
- Minimizing the amount of disturbed area.
- Backfill exposed construction site as soon as possible.

Post-mitigation, the residual impacts will be negligible in magnitude.

### 8.7.2 **Construction Phase: Fauna**

#### 8.7.2.1 *Habitat Loss*

During the construction phase of the proposed project, there is potential for fauna habitat loss due to ground disturbance, soil compaction from heavy equipment use and clearing activities at the WWTP and from off-road collection system installation. As indicated previously, it is estimated that approximately 350 m<sup>2</sup> of low-value habitat typical of an overgrown empty lot will be lost due to the construction of WWTP site. For the collection system construction, areas of off-road construction may disturb habitats. Habitat loss is considered moderate.



As indicated in Section 5, there are several places in the general vicinity of the proposed WWTP site which have a far greater value for local wildlife than the proposed site. The small mangrove woodland at the mouth of Ciperó, located west of the site, is one of these locations. To mitigate the off-road collection system construction, sites will be restored as soon as possible, and trenchless technology will be used along the Marabella and Ciperó Rivers to minimize the amount of disruption.

Post-mitigation, the residual impact will be negligible to minor. The WWTP site habitat loss will be permanent (lasting the life of the facility). The habitat loss resulting from the collection system construction will occur once for short term duration but will be reversible. The impacts are considered local at the construction site.

#### 8.7.2.2 *Habitat Modification*

Habitats may be affected due to siltation from erosion activities. This could have a moderate impact on an intermittent basis.

Mitigation measures proposed include:

- Construction sequencing of work, to minimize the amount of exposed sites, as detailed in Section 3.12.
- Cover or backfill trenches as soon as possible.
- Locate stockpiles away from watercourses, and minimize the amount of material stockpiled on site.

With mitigation, impacts of habitat modifications during the construction phase are anticipated to be negative, negligible to minor in magnitude and anticipated to occur intermittently over the short term on a local scale.

#### 8.7.3 **Operation Phase: Flora**

During the operation phase of the San Fernando wastewater project, interaction with flora will include maintaining the WWTP and lift station sites to keep the grass cut and landscaping under control. This will present a negligible impact to the flora within the project area.

#### 8.7.4 **Operation Phase: Fauna**

##### 8.7.4.1 *Aquatic Fauna Species Growth*

As seen in Section 8.5.2 once the project is fully constructed, the positive impact to the water quality is expected to generate a positive impact to the aquatic fauna species through improvements to water quality. As indicated in Section 5, aquatic fauna studies returned a small sample size and low diversity of species, with one of the factors attributed to the polluted nature of the sample stations. Once fully constructed, the amount of pollution entering the waterways will be decreased, creating a more hospitable environment and result in an increase of aquatic fauna species. This results in a major regional long term positive impact.

##### 8.7.4.2 *Avifauna Habitat Modifications*

Avifauna appear to tolerate and possibly benefit from the very high nutrient content currently in the river water, and dried sludge at the existing SFWWTP. They often congregate around areas such as the



Cipero River mouth, and WWTP sludge drying beds. These birds feed on high populations of invertebrates supported by the high nutrient load but the exposure to pollutants may impact the birds' longevity and reproduction (White, 2009). With the decrease of pollutants to the waterways, and removal of sludge drying beds, fewer birds may be apparent, and may need to relocate their feeding grounds. While the distance that the avifauna may need to travel to feed could increase, resulting in a minor negative impact, the positive impact to the health of the population provides an overall positive impact to the avifauna community.

#### 8.7.4.3 Lighting

Lighting at the WWTP site will be used for security and night time maintenance, as is the current situation at the existing WWTP. This could result in a minor negative impact to the fauna around the Site.

Mitigation measures include directing the lights inside of the site, and will be as unobtrusive as possible.

Post-mitigation, the residual impact to fauna will be negligible and on a local scale.

## 8.8 Traffic Impacts and Mitigation

### 8.8.1 Construction Phase

During the construction phase of the project, there will be an increase in traffic to the WWTP site, as well as traffic disruptions when the collection system is installed in road right-of-ways.

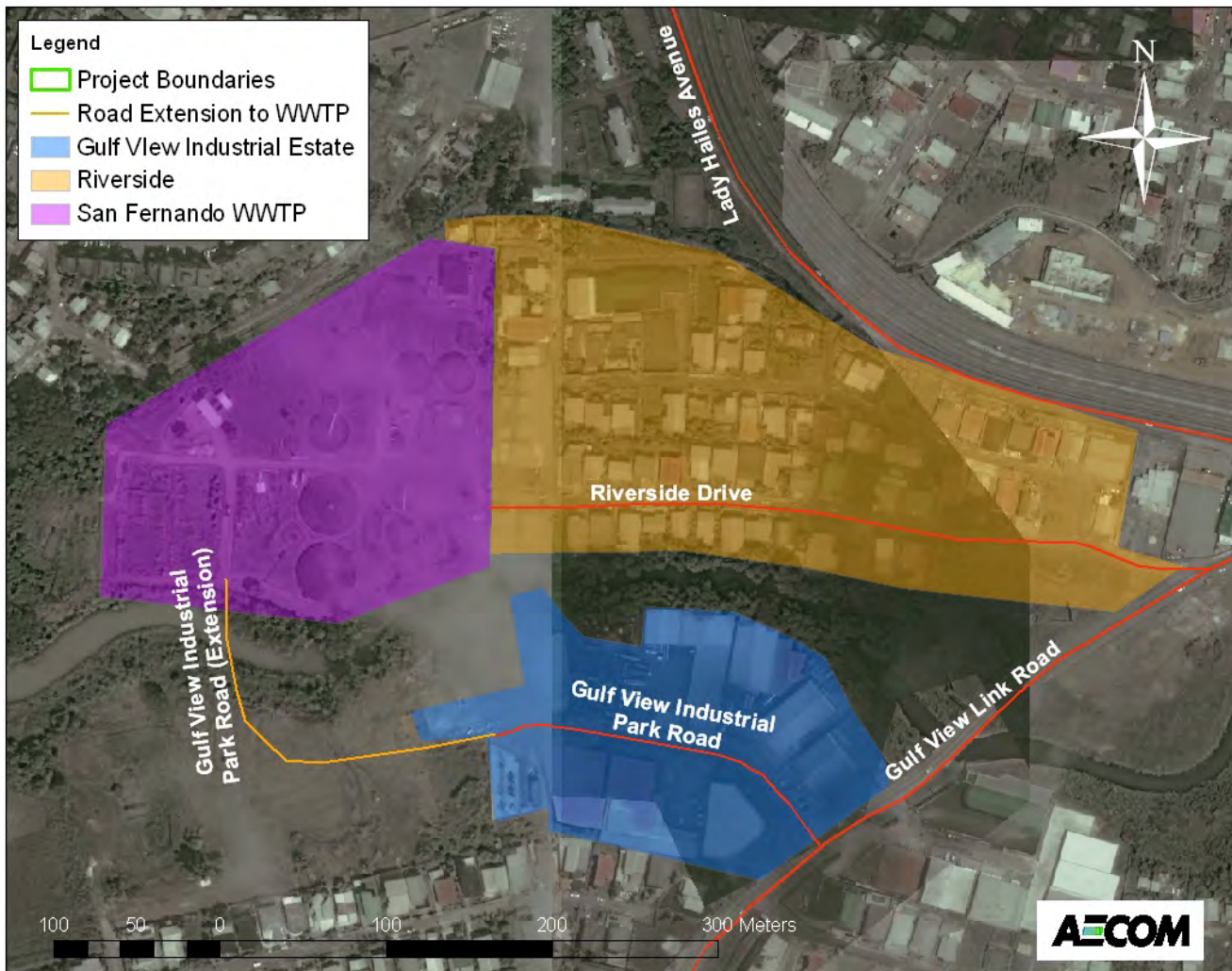
#### 8.8.1.1 WWTP Traffic

Traffic to and from the WWTP site is discussed in Section 3.12.8, and could be up to 50 vehicle trips per day. The impact and associated mitigation measures of vehicle emissions and dust to air quality are discussed in Section 8.3.1. The existing access to the WWTP is through Riverside Drive, a residential area. The increase of traffic to the site would have a medium duration impact over the 2 year construction.

This would affect a minor percentage of the project population, mainly the residents and business owners who use Riverside Drive. This impact would be continuous throughout the construction day.

To mitigate this impact, an alternate entrance to the WWTP is planned through the Gulf View Industrial Park, located south of the Cipero River. This entrance would be less disruptive to homeowners who use Riverside Drive. Carpooling to the site for workers, and regular vehicle maintenance will also be encouraged to reduce potential impacts due to the increase in traffic.

The areas impacted, pre and post-mitigation are shown in Figure 8-1. By relocating the entrance of the WWTP site, 8 businesses in the Gulf View Industrial Park will be impacted by traffic to the site, instead of 86 residential and business dwellings who utilize Riverside Drive. This traffic will still impact a minor percentage of the project population; however the affected population is lower than pre-mitigation. The construction traffic will be continuous throughout the construction day for the 2 year construction. Effects are anticipated to be local occurring throughout the construction day with effects being of short term duration and are considered reversible.



**Figure 8-1 Area of Traffic Influence of Entrance to San Fernando WWTP**

*8.8.1.2 Collection System Traffic*

Open trench collection system construction in road right-of-ways (ROW) involves closing either one lane of traffic or the entire road for construction to occur. Areas will be required for construction staging and storage of material, which may be in road ROW.

High traffic volumes on some roads in the San Fernando area mean that traffic disruptions caused by collection system construction in roadways will have a major impact to the population of the San Fernando region. The impact duration would be short term on a local scale. This short term duration construction will occur throughout the project area for the duration of the construction phase.

It was recognized early in the design process that mitigation measures for traffic would be required. Contractors will be required to submit a detailed traffic management plan and have it approved before any roadway construction commences. The traffic management plan will need to be in accordance with the traffic control specification.



### Traffic Control Specification

The traffic control specification is located in the contractor tender documents, and **Appendix G.2**. A summary of the specification follows.

### Vehicular Traffic Control

Traffic control is required for work in any ROW, including in or adjacent to streets, back lanes and highways. All road closures will need to be in accordance with the Traffic Management Plan. Provide and maintain reasonable road access and egress to properties fronting along or in vicinity of Work unless other reasonable means of road access exist.

The specific traffic control measures are dependant on the size of the road that is affected by construction. All main roads should have plans for well graded, gravelled detours or temporary roads for that are suitable for service vehicles. The main roads include:

- Solomon Hochoy Highway
- San Fernando By Pass
- South Trunk Road
- Southern Main Road
- Lady Hailes
- Naparima-Mayaro
- Tarouba Link Road
- Guaracara-Tabaquite Road
- Union Hall Road
- Ciperio Road
- Manahambre Road
- Dumfries Road
- Palmiste Blvd
- San Fernando Siparia Erin Road

On other roads where there is access from both ends, maintain local access from both ends at all times during construction. In areas where only single access exists, maintain this access to the degree possible during construction. If road closure is unavoidable, restrict to between the hours of 8:00 a.m. and 5:00 p.m. On residential streets and cul-de-sacs maintain access and/or parking between the hours of 5:00 p.m. and 8:00 a.m.

### Flag persons

Provide properly equipped flag persons, in the following situations:

- When public traffic is required to pass working vehicles or equipment which may block all or part of travelled roadway.
- When it is necessary to institute one-way traffic system through construction area or other blockage where traffic volumes are heavy, approach speeds are high and traffic signal system is not in use.
- When workers or equipment are employed on travelled way at other locations where oncoming traffic would not otherwise have adequate warning.



- Where temporary protection is required while other traffic control devices are being erected or taken down.
- For emergency protection when other traffic control devices are not readily available.
- In situations where complete protection for workers, working equipment and public traffic is not provided by other traffic control devices.

### Signage

Signs and other devices that indicate construction activities or other temporary and unusual conditions will be provided and maintained by the Contractor. This includes:

- For streets or back lanes along or in which construction is occurring, and for areas where construction vehicles are entering or leaving streets or back lanes warning signs informing traffic of construction activities ahead and restricting roadway to local traffic only.
- For roadway restricted to one way travel traffic control signs at cross streets, back lanes, and 31 m intervals between.
- For unpaved trenches and other disturbed areas in pavement flashing light barricades, to channelize traffic into undisturbed pavement.
- At cross streets and back lanes flashing light barricades, to screen off disturbed areas in trenches.
- Where permanent traffic signals disturbed by construction operation temporary traffic signals. These signals shall have same general signalling sequence and indicator arrangement as permanent signals removed except as necessary to be compatible with construction operations.
- Installation of temporary signals in other areas as necessary to protect public and aid travel of construction vehicles. Such installation shall be approved by Employers Personnel and appropriate maintaining agency.
- Provide temporary type pavement markings on replacement pavement surfaces. Markings shall match existing marking patterns. Place markings on temporary bituminous pavements, base courses of bituminous final pavements to be left more than 3 days without applying final courses, and final bituminous and concrete pavement surfaces.
- Protect drop off greater than 8 cm, but less than 16 cm within 2.5 m of pavement edge by barricades equipped with mono directional steady burn lights at 15.5 m centre to centre spacing. If drop off within 2.5m of pavement edge exceeds 8 cm. but less than .6 m, barricades shall be placed at 7.6 m centre to centre spacing. Barricades placed in excavated areas shall have leg extensions installed such that top of barricade is in compliance with height requirements of Traffic Branch.
- Placement of signs and barricades shall proceed in direction of flow of traffic. Remove signs and barricades at end of construction area and proceed toward oncoming traffic unless otherwise approved by Employers Personnel.

### Traffic Management Plan

The traffic control specification requires the contractor to prepare a detailed Traffic Management Plan including:

- A schedule of street and walkway closing, partial closings and detours.
  - Dates and duration of stages and closures.
  - Contractor's contact person(s) with 24 hour telephone number.





- Contact agencies with telephone numbers as applicable: Employer, Regional Corporation, Fire Department, Ministry of Works and Transport, Public Works Department, Police (Traffic Branch), Public Transport Service Corporation (PTSC), Trinidad and Tobago Unified Maxi Taxi Association, Schools, Hospitals, and other effected agencies.
- This schedule must remain current and be updated throughout the project.
- Procedures for pedestrian and vehicular traffic routing and protection in immediate construction area and surrounding area during working and nonworking hours.
- Plans to minimize potential traffic disruptions resulting from construction of the sewers in the roadways.
- Plans to minimize delays of public transit vehicles.
- Plans to minimize dust and mud.
- Plans to reduce the length of detours to the degree possible.

### Traffic Control Committee

A traffic control committee is required to be set up to expedite traffic control planning strategies and the necessary approval process. The committee will consist of the following parties:

- Contractor's Representative (Traffic Manager).
- Engineer.
- Employer's Representative.
- Representative from each of responsible regulatory authorities including, but not limited to the Employer, Regional Corporation, Fire Department, Ministry of Works and Transport Highways Division, Ministry of Local Government, Police (Traffic Branch), Public Transport Service Corporation (PTSC), Trinidad and Tobago Unified Maxi Taxi Association, Schools, Hospitals, and other effected agencies.
- Representatives from commercial businesses, hotels, restaurants, etc. which are affected during construction.

### Construction Phasing

The collection system will be constructed in phases based on subcatchments. A description of this activity is located in Section 3.12. By constructing in phases, the traffic impacts would be minimized to a local, short term scale.

### Trenchless Technology

To minimize the impact that open trench construction will cause in high-traffic areas, trenchless technology construction will be utilized along the following roads.

- Solomon Hochoy Highway trenchless technology used to cross the highway.
- San Fernando Bye Pass has construction off-road, and trenchless technology to cross the road.
- Tarouba Link Road has construction off-road, and trenchless technology to cross the road.
- Lady Hailes has trenchless technology construction.
- Cipero Road has trenchless technology construction.



These roads displayed high traffic counts in Section 5. By employing trenchless technology in these areas, the impact of construction would be minimized from a regional to a local scope.

#### Collection System Construction Phase Post-Mitigation

With the traffic control specification, traffic management plan, and trenchless technology construction, the post-mitigation impacts are minor to moderate in magnitude and short-term on a local scale. The frequency of impact will be continuous during construction with impacts considered reversible.

### 8.8.2 Operation Phase

As shown in Table 8-3, the anticipated traffic to the WWTP site during operation will be 56 vehicles less than the current operation of the WWTP. An alternate entrance to the WWTP to be provided through the Gulf View Industrial Park, located south of the Ciperro River. This entrance would be less disruptive to homeowners who use Riverside Drive. While this results in a positive impact to the residents and business owners who utilize Riverside Drive, businesses in the Gulf View Industrial Park will be impacted by this entrance modification.

The businesses in the Gulf View Industrial Park will experience 150 vehicles per week to the WWTP site. On a weekday, this will be approximately 28 vehicles per day. These vehicles will be staggered throughout the day, with peaks of 10-12 vehicles during the morning and afternoon, when the majority of staff will be coming and going from the site.

This will result in a negligible to minor increase in traffic in the area of Gulf View Industrial Park.

To mitigate potential effects on local business, the following measures will be encouraged:

- Staggered shifts for workers.
- Encouraging carpooling to site.

Post-mitigation, the impact on local businesses due to increased traffic in the Gulf View Industrial Park would be negligible. This impact will occur intermittently over the life of the WWTP with impacts considered reversible.

## 8.9 Social Impacts and Mitigation

### 8.9.1 Construction

#### 8.9.1.1 Use of Labour

With construction phasing, there will be employment opportunities throughout the construction period for skilled and general labour. Although employment might be temporary, it is essential that persons from the local communities with the requisite skills be given preference in terms of employment. The use of transparent and non-discriminatory hiring practices should be utilized. The increased use of local labour is considered a positive impact that will affect a minor portion of the population on a regional or island scale (if required). The employment would last for a medium duration, over the construction phase.



### 8.9.1.2 Land Acquisition

The location of the proposed San Fernando WWTP is on the site of the existing WWTP. Expansion to the west of the site is onto land also owned by WASA. Land south of the Cipero is also owned by WASA and will be used for the new access road and for construction lay down and staging.

Land will need to be acquired for the eight lift stations to be constructed. Section 3.11.1 has a description of this project activity.

While the majority of the new sewers will be constructed in public roadways, several sewer alignments will be located off-road. For these alignments it will be necessary for the construction contractor to obtain construction easements, and for WASA to obtain permanent easements for maintenance purposes.

Obtaining permanent land easements is considered a minor negative social impact as land will have development constraints associated with it for the land owner. However, as the easement process will likely involve negotiations with land owners for appropriate compensation, impacts are considered mitigated. Once the land is acquired it will be for the life of the project, on a local scale.

To mitigate the impact of acquiring land for lift stations and sewer alignments, all areas chosen are on undeveloped land or existing WWTP sites. By acquiring the existing Sunkist and Palmiste WWTP sites, these lots will be improved as they are currently abandoned and overgrown. This will result in a positive impact to these sites.

Post-mitigation, the impact of land acquisition will be negligible. This will be on a long-term duration, on a local scale.

### 8.9.1.3 Health and Injuries

Use of construction equipment and machinery on site, has the potential to impact workers or residents by generating dust and noise as well as by generating safety concerns. Dust and noise concerns will be mitigated as presented in Section 8.3.1.

Accidents are discussed in Section 8.12.

The impact of having untrained workers on a construction site (unmitigated impact), around equipment and machinery could potentially be considered a major negative impact as it could result in death or serious injury.

To prevent human health impacts, mitigation measures include:

- Hire experienced workers trained in worker health and safety.
- Educate and train workers on health and safety concerns arising from construction.
- WASA and Contractor to enforce health and safety program
- Only allowing qualified staff to operate machinery and equipment.

Post-mitigation, the impact will be minor to negligible on a local scale. Post mitigation impacts are considered reversible as it is assumed that the mitigation measures will prevent and minimize the potential for severe human health impacts during the construction phase.



#### 8.9.1.4 *Storage and Staging of Stockpiles of Materials, and Chemicals*

During construction, materials and chemicals as well as construction debris and waste may need to be stored on site. Discussions into the impacts of airborne dust and particles, and fuel and chemical spills on air, soil, and water have been discussed in previous sections. Human impacts due to accidents and malfunctions (including health hazards due to spills, trip hazards, and crush hazards) are discussed in Section 8.12.

Residents or business owners could be prevented from accessing their properties due to storing or staging of materials. Temporary visual intrusion of landscape features may also occur. This would result in a negative impact to a minor portion of the project population for a short duration.

Mitigation measures include:

- Construction site organization so as not to block any residential or businesses entry points due to storage and staging of materials. If unavoidable, provisions for alternate access must be provided.
- Keep work areas, including storage and stockpile areas tidy and limited to reasonable heights. Topsoil stockpiles not to exceed 2 m.

Post mitigation, the impact will be negligible. This would occur over a short duration on a local scale.

#### 8.9.1.5 *Use of Lighting*

During construction, some work may occur during times when lighting is required. This lighting may impact the residents located around the construction site due to daily activity disruption. The impact would be negative to a minor percentage of the project population.

To mitigate this impact, restrictions will be placed on working outside of normal daytime working hours. Where night work is necessary, construction workers will direct lights to the construction site area, and not towards resident's homes. Further, if complaints are received by local residents, WASA will work with the affected residents towards a mutually agreeable solution.

Post mitigation, the impact will be negligible. This would occur over a short duration on a local scale.

### 8.9.2 **Operation**

#### 8.9.2.1 *Use of Labour*

During the operation and maintenance of the WWTP and lift stations, the system will be operated by the contractor on a short term basis until the issuance of the Taking Over Certificate and after this time plant operations personnel will be provided by WASA.



The anticipated on-site staff needed to operate and maintain the new WWTP is as follows:

Managerial	3
Administrative support	2
Operations	6
Laboratory	2
Maintenance	5
<hr/>	<hr/>
Total	18

Additional staff will be required for maintenance of the collection system and lift stations. The anticipated field staff will include two crews each comprising a crew chief and two labourers. Their office base will be near the WWTP, possibly in a future facility located on the WASA land south of the Ciperó River. This results in a total of 24 staff.

Currently, there is 28 staff employed at the WWTP, including collection system maintenance.

This decrease to the amount of staff will have a negative impact to the four employees who will not be required anymore.

To mitigate this job loss, the four employees will be transferred to other wastewater sites or collections systems within Trinidad. WASA could also choose to operate the plant and collection system with additional staff.

This residual impact would be negligible. Workers could have a different length of time to travel to work; however it is uncertain at this time if it would be greater or less than their current situation. This would occur over the long term.

#### 8.9.2.2 Economics

With the implementation of the San Fernando Wastewater Project, water and sewer rates could have been increased in order to fund the project. This would result in a negative impact to all residents of Trinidad and Tobago who pay WASA fees. This would impact a major portion of the country.

To mitigate this impact, WASA will not be increasing their water and sewer rates due to the construction of the San Fernando Wastewater Project. Only when water rates are increased for the country as a whole then there will be an increase in sewage rates. If a resident is currently connected to WASA's sewer system, there will be no additional increase to their fees. However, some residents may experience additional costs to connect to the sewer system.

For residents who are not currently connected to WASA's sewer service, this will be an additional user fee once the project is fully constructed. Depending on how often the homeowner has their septic tank or soak-away cleaned, and considering the cost to maintain this system, the overall cost may be a neutral change, or negative change due to an increase in fees.

This post mitigation, impact may be neutral or negative for the population currently not sewered within the project boundaries. This would affect a major portion of the population within the project boundaries. The exact impact to residents would need to be studied on a per-person basis, considering the current costs of maintaining alternate wastewater containment systems.



### 8.9.2.3 Use of Lighting

The WWTP site will be a lighted site, which could negatively impact a minor portion of the project population who reside beside the site.

Mitigation measures include:

- Directing the lights inside the site.
- Installation of WireWall® fencing which will assist in blocking the light.
- If complaints are received by local residents, WASA will work with the affected residents towards a mutually agreeable solution.

Post mitigation, the impact to the local population will be negligible.

### 8.9.2.4 Water Quality Improvement

The operation phase of the project, when fully constructed, will have a major positive impact on the San Fernando Project regional area. This will be a long term, continuous impact. From a social perspective this should assist in decreasing community concerns over the environment and pollution, as seen in Section 6. With the improvement to water quality, further fishing activities may also occur, which could be an economic benefit.

## 8.10 Cumulative Impacts and Mitigation

### 8.10.1 Existing and Proposed Construction Projects

San Fernando has existing construction projects that may generate cumulative impacts to traffic and air quality, however these will need to be addressed on a case by case basis when this project begins the construction work. All new building construction within the project boundaries will be connected to the proposed wastewater collection system.

At the time of conducting the EIA Study, the National Academy of Performing Arts (NAPA) – South Centre was being constructed on Todd Street at Rienzi Kirton Highway. Construction of the collection system will occur on the north side of the Ciperio River, using trenchless technology. This is approximately 130 m from the NAPA site. Traffic and air quality impacts of the collection system construction have the potential to be cumulative with the impacts generated by the Centre construction.

In all cases where there is ongoing construction from other projects that will be in the vicinity of collection system construction, mitigation measures should include:

- Construction phasing of the collection system could be modified to bypass the area until the other project(s) are complete.
- Communication between the collection system and other project(s) contractors to determine how the projects will impact each other. All actions to be approved by WASA.
- Traffic management that considers construction traffic from the other project(s).
- Dust and noise mitigation measures shown in Section 8.3.1, will need to be closely monitored and enforced.



With the implementation of these mitigation measures, the magnitude of impact should be decreased. This will be studied individually on a case-by-case basis.

### 8.10.2 Utility Installation or Upgrade

The San Fernando wastewater project will involve excavation of roadways in order for the new collection system to be installed, which may expose other existing utilities including water, electricity, and telecommunications, and require rebuilding of drains. Working closely with these utilities and ministries could allow for upgrades of these services at the same time. This would result in a positive impact to the community, as disruptions, and construction work would only occur once for all projects.

### 8.10.3 Untreated Wastewater Discharges

As indicated from the water quality baseline sampling results, the rivers upstream of the catchment area also displayed high Faecal Coliform counts, indicative of untreated wastewater (Section 5.8). The cumulative effect of the additional wastewater entering the rivers within the San Fernando catchment area decreased the water quality further. This resulted in a major negative impact to the river water quality.

By directing all untreated wastewater within the San Fernando Project area boundaries to the proposed WWTP for proper treatment, this cumulative impact is mitigated, resulting in a major positive impact to the river water quality.

## 8.11 Summary of Impacts and Mitigation

A major positive impact from the San Fernando Wastewater Project is the improvement in surface water quality in the region, as a result of the untreated wastewater being properly collected and treated at the new WWTP. Cleaning up the waterways in the catchment area will result in a habitat improvement for aquatic species, improved public health and decrease in waterborne illnesses for humans, and overall improvement in the quality of life.

The most significant negative impact is disruption of traffic flow during construction. Traffic disruption has potential to affect over 10% of the San Fernando and environs population and will impact localized areas throughout the construction process. A significant portion of the construction will be within road right-of-ways. Mitigation of traffic impacts will be accomplished by utilizing trenchless technology in high traffic roadways, and a comprehensive traffic management plan that includes provisions for proper detours and signage, provision of access to all businesses and properties, restrictions on construction hours, and limits on the amount of construction that can occur at any one location. Once these mitigation measures are utilized in the construction, the unmitigated major negative impact becomes a mitigated minor to moderate negative impact.

A summary of the San Fernando Wastewater Project's Impacts and Mitigation measures is contained in Table 8-4.

**Table 8-4 Summary of Project Impacts and Mitigation Measures**

Classification of Potential Impact	Project Phase	Potential Impact	Unmitigated Magnitude of Impact	Mitigation Measures	Post-Mitigation					
					Residual Impact	Direction of Impact	Duration of Impact	Frequency of Impact	Scope of Impact	Degree of Reversibility
Air Quality	Construction	Exhaust Emissions	Minor on site, negligible off site Negative	<ul style="list-style-type: none"> <li>• Carpool to site</li> <li>• Keep vehicle idling to a minimum</li> <li>• Perform vehicle inspections and maintain equipment</li> </ul>	Minor on site, Negligible off site	Negative	Medium	Continuous during working hours	Local	Reversible
		Airborne dust and particles	Minor Negative	<ul style="list-style-type: none"> <li>• Dust suppression activities (water roads and exposed ground)</li> <li>• Minimize disturbed areas</li> <li>• Backfill exposed construction site as soon as possible - Stockpile height of topsoil maximum 2m</li> </ul>	Minor on site, Negligible off-site	Negative	Medium	Intermittent	Local	Reversible
		Odours	Minor to Moderate Negative	<ul style="list-style-type: none"> <li>• Conduct sludge drying bed excavation when wind is directed to SW</li> <li>• Odour suppression equipment at new septage receiving station</li> <li>• Use chemicals ensuring OSHA rules are followed</li> </ul>	Negligible	Negative	Short	Intermittent to Continuous	Local	Reversible
	Operation	Exhaust Emissions	Minor Positive	-	-	-	Long	Continuous	Local	-
		Airborne dust and particles	Minor Negative	<ul style="list-style-type: none"> <li>• Replacing sludge drying beds with contained processes</li> <li>• Paving WWTP Site Roads</li> <li>• Bioreactor design produces less aerosols and has additional tank freeboard</li> </ul>	Negligible	Negative	Long	Continuous	Local	Reversible
		Odours	Minor to Moderate Negative	<ul style="list-style-type: none"> <li>• Storing screenings and grit in dumpsters instead of on the ground.</li> <li>• Covering the dumpsters used to store the screenings, grit and biosolids.</li> <li>• Ensuring all waste is hauled off-site on a scheduled and timely basis</li> <li>• Construction of a contained septage receiving station, with odour control.</li> <li>• Maintaining odour suppression equipment.</li> <li>• Decommissioning of existing trickling filters.</li> <li>• Conversion of anaerobic digesters to aerobic digesters. Hydrogen sulphide is not generated as a by-product gas of this process.</li> </ul>	Negligible	Negative	Long	Intermittent	Local	Reversible
Noise	Construction	Noise from vehicles, equipment, and construction	Minor to Moderate Negative	<ul style="list-style-type: none"> <li>• Construction during daytime hours</li> <li>• Keep vehicle idling to a minimum</li> <li>• Design considerations including acoustic enclosures</li> <li>• Maintain vehicles and equipment</li> </ul>	Minor to Moderate	Negative	Medium	Continuous during working hours	Local	Reversible
	Operation	Operational Noise	Moderate	<ul style="list-style-type: none"> <li>• Acoustic suppression enclosures</li> <li>• Service equipment</li> </ul>	Negligible	Negative	Long	Continuous	Local	Reversible



**Table 8-4 Summary of Project Impacts and Mitigation Measures (continued)**

Classification of Potential Impact	Project Phase	Potential Impact	Unmitigated Magnitude of Impact	Mitigation Measures	Post-Mitigation					
					Residual Impact	Direction of Impact	Duration of Impact	Frequency of Impact	Scope of Impact	Degree of Reversibility
Water	Construction	Land Clearing and excavation along watercourses	Minor Negative	<ul style="list-style-type: none"> <li>Water from site must have TSS &lt;30 mg/L</li> <li>Erosion control blankets</li> <li>Bank stabilization</li> <li>Not allow dumping of excavated fill, waste material or debris into watercourses</li> <li>Drainage works with approval of Ministry of Works</li> </ul>	Negligible	Negative	Short	Intermittent	Local	Reversible
		Release of untreated wastewater from San Fernando WWTP	Major Negative	<ul style="list-style-type: none"> <li>Construction sequencing ensures wastewater is treated throughout construction process</li> </ul>	Negligible	Negative	Medium	Continuous	Local	Reversible
	Operation	Release of untreated wastewater from San Fernando WWTP	Major Negative	<ul style="list-style-type: none"> <li>Redundancy in WWTP design</li> <li>Storm water storage to treat through plant once storm subsides</li> </ul>	Negligible	Negative	Short	Rare	Local	Reversible
		Water Quality Improvement	Major Positive	-	-	Positive	Long	Continuous	Regional	-
		Potable Water Use	Minor Positive	-	-	Positive	Long	Continuous	Local to Regional	-
Soil	Construction	Erosion	Moderate Negative	<ul style="list-style-type: none"> <li>Construction sequencing</li> <li>Locate stockpiles away from watercourses Minimize amount of stockpiles</li> <li>Cover or backfill trenches as soon as possible</li> </ul>	Negligible to Minor	Negative	Short	Intermittent	Local	Reversible
		Soil Compaction	Minor Negative	<ul style="list-style-type: none"> <li>Level sites and fill (if required) to restore to pre-construction grades</li> </ul>	Negligible	Negative	Short	Intermittent	Local	Reversible
		Sludge Management	Minor Negative	<ul style="list-style-type: none"> <li>Excavate previously buried sludge, grit and screenings and dispose of at a landfill</li> </ul>	Negligible	Positive	Long	Once	Local	-

**Table 8-4 Summary of Project Impacts and Mitigation Measures (continued)**

Classification of Potential Impact	Project Phase	Potential Impact	Unmitigated Magnitude of Impact	Mitigation Measures	Post-Mitigation					
					Residual Impact	Direction of Impact	Duration of Impact	Frequency of Impact	Scope of Impact	Degree of Reversibility
Soil	Operation	Erosion from Outfall	Moderate Negative	<ul style="list-style-type: none"> <li>Design outfall to prevent erosion</li> <li>Maintain outfall channel construction</li> </ul>	Negligible	Negative	Long	Continuous	Local	Reversible
Flora	Construction	Species Loss	Minor to Major Negative	<ul style="list-style-type: none"> <li>Design to avoid key species</li> <li>Re-establish any riparian forest</li> </ul>	Negligible to Minor	Negative	Short to Long	Once	Local	Reversible
		Dust Deposition	Minor to Negligible Negative	<ul style="list-style-type: none"> <li>Dust suppression activities</li> <li>Minimize the amount of disturbed area</li> <li>Backfill exposed sites as soon as possible</li> </ul>	Negligible	Negative	Short	Intermittent	Local	Reversible
	Operation	Landscaping	Negligible	-	-	Neutral	Long	Intermittent	Local	-
Fauna	Construction	Habitat Loss	Moderate Negative	<ul style="list-style-type: none"> <li>Restore off road collection system construction quickly</li> <li>Use trenchless technology on some sewer construction</li> </ul>	Negligible to Minor	Negative	Short to Long	Once for collection system construction, continuous or WWTP construction	Local	Reversible
		Habitat Modification	Moderate Negative	<ul style="list-style-type: none"> <li>Restore off road collection system construction quickly</li> <li>Locate stockpiles away from watercourses</li> <li>Cover or backfill trenches as soon as possible</li> </ul>	Negligible to Minor	Negative	Short	Intermittent	Local	Reversible
	Operation	Habitat Modifications	Moderate Positive	-	-	Positive	Long	Continuous	Regional	-
		Aquatic Fauna Species Growth	Major Positive	-	-	Positive	Long	Continuous	Regional	-
		Lighting	Minor Negative	<ul style="list-style-type: none"> <li>Focus lighting within Site.</li> </ul>	Negligible	Negative	Long	Continuous during evening	Local	Reversible
Traffic	Construction	Traffic increase to site	Minor Negative	<ul style="list-style-type: none"> <li>Construct new entrance to site through Gulf View Industrial Park</li> <li>Encourage carpooling</li> </ul>	Minor	Negative	Medium	Continuous over construction day	Local	Reversible
		Traffic disruptions from collection system road right of way construction	Major Negative	<ul style="list-style-type: none"> <li>Traffic control specification.</li> <li>Traffic management plan</li> <li>Trenchless technology on high traffic roads</li> </ul>	Minor to Moderate	Negative	Short	Continuous	Local	Reversible

**Table 8-4 Summary of Project Impacts and Mitigation Measures (continued)**

Classification of Potential Impact	Project Phase	Potential Impact	Unmitigated Magnitude of Impact	Mitigation Measures	Post-Mitigation					
					Residual Impact	Direction of Impact	Duration of Impact	Frequency of Impact	Scope of Impact	Degree of Reversibility
Traffic	Operation	Traffic increase to site	Negligible to Minor Negative	<ul style="list-style-type: none"> <li>Construct new entrance to site through Gulf View Industrial Park</li> <li>Staggered shifts for workers</li> <li>Encourage carpooling</li> </ul>	Negligible	Negative	Long	Continuous	Local	Reversible
Social	Construction	Labour Requirement	Minor Positive	-	-	Positive	Medium	Continuous	Regional to National	-
		Land Acquisition	Minor Negative to Positive (site dependant)	<ul style="list-style-type: none"> <li>Acquire existing WWTP and lift station sites, and empty land</li> <li>Compensate landowners</li> </ul>	Negligible	Negative to Positive	Long	Continuous	Local	Reversible
		Health and Injuries	Minor to Major Negative	<ul style="list-style-type: none"> <li>Health and safety policy</li> <li>Only allow qualified staff to operate machinery and equipment</li> </ul>	Minor to Negligible	Negative	Short	Once to Intermittent	Local	Reversible to irreversible
		Blocked properties and visual intrusion from construction material	Minor Negative	<ul style="list-style-type: none"> <li>Construction site organization to not block access to buildings, or provide alternate access</li> <li>Keep work areas tidy and stockpiles at reasonable heights</li> </ul>	Negligible	Negative	Short	Intermittent to Continuous	Local	Reversible
	Use of lighting	Minor Negative	<ul style="list-style-type: none"> <li>Direct lights to construction site area and not towards resident's homes</li> <li>Receive and respond to resident complaints</li> </ul>	Negligible	Negative	Short	Intermittent	Local	Reversible	
	Operation	Labour Requirement	Minor Negative	<ul style="list-style-type: none"> <li>Relocate workers within WASA to other projects, or operate the plant with additional workers</li> </ul>	Negligible	Negative	Long	Continuous	Local to Regional	Reversible

**Table 8-4 Summary of Project Impacts and Mitigation Measures (continued)**

Classification of Potential Impact	Project Phase	Potential Impact	Unmitigated Magnitude of Impact	Mitigation Measures	Post-Mitigation					
					Residual Impact	Direction of Impact	Duration of Impact	Frequency of Impact	Scope of Impact	Degree of Reversibility
Social	Operation	Economics – Change to Wastewater Fees	Major for Country Negative	<ul style="list-style-type: none"> <li>No change to water rates due to project.</li> <li>Additional fee may be neutral when cost of septic tank or soakaway cleaning and maintenance is considered.</li> </ul>	Major	Neutral to Negative	Long	Continuous	Regional	Reversible
		Use of lighting	Minor	<ul style="list-style-type: none"> <li>Directing lighting inside the Site.</li> <li>Installation of WireWall® fencing to decrease light penetration</li> <li>Receive and respond to resident complaints</li> </ul>	Negligible	Negative	Long	Continuous during evenings	Local	Reversible
		Water Quality Improvement	Major Positive	-	-	Positive	Long	Continuous	Regional	-
Cumulative	Construction	Other construction projects within San Fernando Area	To be studied on a case-by-case basis throughout construction	<ul style="list-style-type: none"> <li>Construction phasing to bypass area until other project is complete</li> <li>Communication between contractors</li> <li>Traffic management plan to consider all construction</li> <li>Dust and Noise mitigation measures to be closely monitored and enforced</li> </ul>	To be studied on a case-by-case basis throughout construction	Negative	Short	To be studied on a case-by-case basis throughout construction	Local to Regional	Reversible
		Utility upgrade or installation at same time as collection system work	Minor to Major Positive	-	-	Positive	Short	Continuous	Local to Regional	-
	Operation	Water Quality Improvement	Major Positive	-	-	Positive	Long	Continuous	Regional	-



## 8.12 Accidents and Malfunctions

Accidents and malfunctions are considered any event that can occur which could potentially lead to impacts to the biophysical and social environment around and within the project area. This may be as a result of an action from the project but not necessarily a project component. The accidents and malfunctions that can occur will be discussed for all phases of the project, specifically construction, operation and decommissioning of existing facilities. The probable accidents and malfunction impacts and mitigation measures of the San Fernando Wastewater Project will be discussed according to the following themes (Table 8-5).

- Spills
- Process disruptions
- Natural disasters
- Power failures
- Fires
- Injury/death/accidents

### 8.12.1 Spills

#### 8.12.1.1 Impacts

The potential of a spill occurring is likely in all stages of the project. The spilled substance may be hazardous or non-hazardous which will include for the San Fernando Project:

- Untreated wastewater (hazardous)
- Sodium hypochlorite (hazardous)
- Polymer (non-hazardous)
- Dewatered sludge (non-hazardous)
- Fuels (hazardous)

#### Untreated Wastewater

The impact of a spillage will vary based on the characteristic of the material and the environment in which it was discharged into. Wastewater spills may occur at the WWTP and lift station sites or through a sewer main. If a wastewater spill were to occur at the WWTP, the magnitude of the impact will be negligible on-site since it would be easier to contain. However, if the wastewater spill at the WWTP flows down to the Ciperio River the impact would be moderate and may occur on a regional scale affecting all communities downstream of the River, including; Broadway and Gulf View. The effects if this were to occur are:

- Decreased river water quality
- Foul odour
- Potential human health effects

Where a wastewater spill occurs at the lift stations, the impact magnitude will vary based on location. The La Romain Central Lift Station is located near to a school and therefore the magnitude of an untreated sewage spill may be moderate but on a local scale. The effect may be the generation of a fetid odour potential for subsequent effects on the health of the students. If wastewater leaks from the



Palmiste Lift Station, because it is located within a residential area, a foul scent will be generated in conjunction with potential indirect human health impacts, for example, presence of vermin attracted to the wastewater which may also transmit diseases. The unmitigated impact is considered minor on a local scale.

If a wastewater spill occurs in any of the lift stations in Bel Air, the impact will be of the same scale typically minor with possibly a regional scale because of the close proximity to the sea, however, a spill large enough to flow into the sea is not expected. The Retrench-Golconda lift station is located near a stream but fairly distant from human civilisation, therefore if a leak occurred the effects may be experienced on a local scale if it does not seep into the river in which case the scope would be regional and a moderate magnitude.

A wastewater leak within the San Fernando Collection System is not expected to occur because the pipes would be of a good quality and installed according to best engineering practices. Nevertheless, if a pipe is fractured and wastewater leaks, the impact magnitude and scale would vary from negligible to minor on a local or regional scale because of the sewer main routes which are mainly located on roadways.

#### Sodium Hypochlorite

Sodium hypochlorite would only be stored and utilized at the WWTP. If a spill were to occur at the site, the impact would be a minor impact on a local scale. The effects of a spill would possibly only be felt by employees that would have been working close to the chemical.

#### Polymers

A polymer spillage can only potentially occur at the WWTP since during the operation phase of the project this substance will be stored and transported there. The polymer used for the process is dry polymer therefore any real impact would occur when this has been mixed and converted to a liquid form. Workers around the site of leakage may be slightly affected but the impact is expected to be negligible on a local scale.

#### Dewatered Sludge

A potential mishap can occur if the dewatered sludge falls out of the transport trucks during transit to the landfill.

The magnitude of this impact would be determined based on the area in which the sludge would have escaped however, the trucks are not expected to pass through any environmentally sensitive locations, and therefore the magnitude of impact may range from negligible to minor on a local scale.

#### Fuels

The fuels that are used for operating the construction equipment will be filled on-site via a fuel truck. There is potential for a fuel spill to occur while the equipment is being re-fuelled. The impact of this would be minor on a local scale affecting only the workers present at the re-fuelling site and the soil where the spill occurred. During a rainfall event, runoff at the site may cause the fuel to spread to nearby drains and streams. The impact of fuel runoff would then be minor in magnitude but on a regional scale.



### 8.12.1.2 Mitigation

The main measures to be implemented to prevent and reduce the effects of these potential impacts include:

- Provisions in the design for spill containment of chemicals in the storage areas.
- Design includes level meters with alarms in the wet wells, shutoff valves and backflow prevention valves to prevent overflows.
- An enforced health and safety plan that details prevention for spills including, spill kits, personal protective equipment, site maintenance and tidiness.
- Availability of Material Safety Data Sheets (MSDS) which list the characteristic of the substance and cleansing methods in the event of a spill.

In the event of wastewater and septage spillage the health and safety plan will contain emergency response procedures in case the leak does occur. The emptying and loading of trucked septage, fuel, and sludge will be done in accordance to best safety practices and will be limited to specific paved areas on the site, thus minimising the area in which a spillage might occur and the extent of damage that may be caused as a result.

Spills will be immediately cleaned using the appropriate procedure based on the substance. The flow of these chemicals into the nearby drainage will not likely occur, and will be contained through proper construction of chemical containment areas. When these mitigation measures are established and practiced the magnitude of a chemical spillage would decrease to negligible on a local scale.

## 8.12.2 Process Disruption

### 8.12.2.1 Impacts

A process disruption will be considered the malfunction of any equipment in the WWTP and lift stations apart from power failure. The impact of a process disruption is specific to the actual process breakdown and the equipment. The magnitude of the impact is indirectly affected by the piece of equipment which would have failed and the extent of damage in order for repair to occur. The impact is expected to be between a negligible and moderate impact on a local or regional scale.

### 8.12.2.2 Mitigation

The mitigation measures that will be employed in the event of a process disruption are incorporated in the WWTP and lift stations design. The design has included for redundancy in all process equipment, including extra pumps, screens, blowers, vortex grit removal chambers and additional features including dual wet wells and storage tanks. Spare parts will be stored on site. Process malfunctions will be treated with extreme attention and mitigation will be employed promptly. Operators will be on-site 24/7 to inspect the equipment and alert relevant person in these cases. Scheduled maintenance of the equipment will occur to prevent breakdown of any process equipment.

Post-mitigation, the impact is expected to be negligible to the WWTP process, and will occur for short-term durations.



### 8.12.3 Natural Hazards

#### 8.12.3.1 Impact

The possibility of a natural hazard affecting the project area is described in Section 5. The likelihood of an earthquake is moderately high with the San Fernando area being affected in the same magnitude as the rest of Trinidad with a major magnitude on a regional scale. Flooding from heavy rainfall, while a low possibility of occurrence in most of the project area (Section 5.3), the WWTP site has a high possibility of occurrence due to its location close to the mouth of the Ciperó River. If a natural hazard were to occur, this would affect the WWTP, lift stations and collection system indirectly creating a hazard to human health in the instance of spillage to wastewater or breakdown of the WWTP resulting in raw sewage discharged into the river.

#### 8.12.3.2 Mitigation

The natural hazard mitigation is instilled in the design of the San Fernando Wastewater Project. The WWTP and lift stations have been designed within the “Zone 3” Uniform Building Code based on expected seismic activity. These structures are also designed for a basic wind speed of 45 metres per second (m/s) which, according to historical storm tracks is not expected in Trinidad. The collection system is also designed with a similar approach.

Flooding of the WWTP site was also mitigated in the design phase of the project. Historical maximum river levels of the Ciperó River were obtained, as well as site visits with operators who have been employed at the current WWTP site confirmed this data. The WWTP is constructed to continue treatment throughout the high water levels of a flood.

Post-mitigation, the impact is expected to be negligible in the event of hurricane and minor the event of earthquake, or flood.

### 8.12.4 Power Failure

#### 8.12.4.1 Impacts

The potential for a power failure to occur is fairly probable and will be determined by the supplier, T&TEC. A power failure event would result in the breakdown of the WWTP and lift stations resulting in raw wastewater back up throughout the collection system with possible overflow to the Ciperó River. This could impact human health and social environment since toilets and drains could back up into homes. The impact could be major on a regional scale therefore affecting the entire project area.

#### 8.12.4.2 Mitigation

The chief mitigation measure for a power failure event is the installation of emergency standby generators which would power the total facility. There would be two generators on-site which would automatically start when the power outage occurs. These generators will be diesel driven and cooled with water and they are equipped to function for a 48 hour period. Backup power will supply 100% of the WWTP site.

Post-mitigation, the impact will be negligible on a local scale.





## 8.12.5 Fire

### 8.12.5.1 Impacts

The possibility of a fire is likely within the project area. The fire may be as a result of a process malfunction or from the spread of a nearby bush fire. The impact of a fire on the WWTP and lift stations will be based on the extent of damage. If the fire is on a small scale and only effects part of the WWTP or lift station structure, then the impact will be minor. Conversely, if the entire structure is engulfed in the fire, then the impact could be of a moderate or major magnitude on a local scale affecting the treatment process and associated works.

The impact of a fire on the sewer pipes is negligible since these structures would be underground. During construction if there is a bush fire nearby then work will have to be postponed. The impact of this would also be negligible.

### 8.12.5.2 Mitigation

The impact of a fire on the WWTP and lift stations can be mitigated by notifying employees of the contact information for the relevant fire services. An emergency response plan will also be completed where an evacuation procedure will be established for all on-duty employees. Fire drills will be carried out to ensure that the emergency response is well-known among staff.

The design of the WWTP also includes fire suppression devices in the administration and utility building. There will be a piped fire water system installed in each building where a hose will be mounted on the wall for complete coverage of the area. Portable chemical fire extinguishers will also be placed at strategic locations including:

- Points of egress
- Laboratory areas
- Kitchens
- Shop areas
- Mechanical rooms
- Electrical rooms
- Storage areas

Post-mitigation the impact of fire is expected to have a minor impact on a rare occurrence.

## 8.12.6 Injury/Death

### 8.12.6.1 Impacts

The impact of an injury will depend on the type of injury and the number of workers affected by the cause of the bodily damage. If the injury is irreversible then the magnitude may be moderate to major for one employee and major if several workers are injured permanently.

In the event of death, the impact will be major if one or more employee dies. The impact of injury or death of by-passers or ordinary persons not involved in the project must also be considered. The expectancy of an event to occur which will endanger the lives of residents not involved in the project is minimal with the implementation of the health and safety measures and other mitigation measures



presented in Section 8. However, any injury or death of a non-employee will be considered a major impact.

#### 8.12.6.2 *Mitigation*

The residual impact of injury and death of both members of staff and persons who are not employed will be reduced to negligible when the following mitigation measures are instated:

- OSH Act of Trinidad and Tobago.
- Treatment plant operator Safety, Health and Environment (SHE) Regulations.
- WASA Health, Safety and Environment (HSE) Policy.

Compliance with the OSH Act of Trinidad and Tobago will be given at all phases of the San Fernando Wastewater Project. The details of the Act are discussed in Section 2 and seek to protect employees from injury and death while on-duty. The AECOM SHE regulations is attached in **Appendix G.3** as a sample manual on ensuring health and safety of the workers are priority for all jobs undertaken by the company. WASA's HSE Policy (**Appendix G.4**) discusses emergency preparedness plans for employees as well as all institutions in place to guarantee the protection of the lives of its staff including the provision of personal protective equipment for all employees. To ensure these health and safety guidelines are followed the Contractor will be responsible for employing appropriate personnel trained in OSHA regulations to make sure the health and safety of workers are the first priority.

**Table 8-5 Summary of Accident and Malfunction Impacts and Mitigation Measures**

Classification of Potential Impact	Potential Impact	Pre-Mitigation				Mitigation Measures	Post-Mitigation			
		Magnitude of Impact	Direction of Impact	Scope of Impact	Degree of Reversibility		Duration of Impact	Frequency of Impact	Scope of Impact	Residual Impact
Spills	Sewage	Negligible to Major	Negative	Regional	Reversible	<ul style="list-style-type: none"> <li>- Maintain Equipment</li> <li>- Emergency response procedure in the event of a sewage leak</li> <li>- Emergency response procedure in the event of a septage spill</li> </ul>	Short	Rare	Local	Negligible
	Sodium Hypochlorite	Minor	Negative	Local	Reversible	<ul style="list-style-type: none"> <li>- Use of MSDS</li> <li>- Health and Safety standards for employees</li> </ul>	Short	Rare	Local	Negligible
	Polymer	Negligible	Negative	Local	Reversible	<ul style="list-style-type: none"> <li>- Use of MSDS</li> <li>- Health and Safety standards for employees</li> </ul>	Short	Rare	Local	Negligible
	Dewatered Sludge	Negligible to Minor	Negative	Local	Reversible	<ul style="list-style-type: none"> <li>- Paved designated area for sludge loading and storage</li> </ul>	Short	Rare	Local	Negligible
	Fuel	Minor	Negative	Local to Regional	Reversible	<ul style="list-style-type: none"> <li>- Paved designated area for equipment fueling</li> </ul>	Short			
Process Disruption	Malfunction of process equipment	Negligible to Moderate	Negative	Regional	Reversible	<ul style="list-style-type: none"> <li>- Scheduled maintenance of equipment</li> <li>- Operators present 24/7</li> </ul>	Short	Rare	Local	Negligible
Natural Hazards	Earthquakes	Major	Negative	Regional	Reversible	<ul style="list-style-type: none"> <li>- Construct in accordance with set earthquake-prevention building code</li> </ul>	Medium	Rare	Local	Minor
	Hurricanes	Minor	Negative	Local	Reversible	<ul style="list-style-type: none"> <li>- Design to resist and protect against high winds</li> </ul>	Short	Rare	Local	Negligible

**Table 8-5 Summary of Accident and Malfunction Impacts and Mitigation Measures (continued)**

Classification of Potential Impact	Potential Impact	Pre-Mitigation				Mitigation Measures	Post-Mitigation			
		Magnitude of Impact	Direction of Impact	Scope of Impact	Degree of Reversibility		Magnitude of Impact	Direction of Impact	Scope of Impact	Degree of Reversibility
	Flood	Major	Negative	Local	Reversible	- Design addresses high water levels and will continue treatment throughout flood event	Short	Rare	Local	Negligible
Power Failure	Shutdown of process equipment	Major	Negative	Regional	Reversible	- Install standby generators that would automatically power 100% of the site during power outages.	Short	Rare	Local	Negligible
Fire	WWTP destroyed by fire	Major	Negative	Regional	Reversible	- Emergency response plan - Routine fire drills - Fire protection system - Portable chemical extinguishers at strategic points	Short	Rare	Local	Minor
Injury/Death	Injury of Employee	Minor to Major	Negative	Local	Reversible	- PPE worn at all times	Short	Rare	Local	Minor
	Injury of non-employee	Minor to Major	Negative	Local	Reversible	- Safety and health rules from GORTT, WASA, AECOM and Contractor instilled	Short	Rare	Local	Negligible
	Death of Employee	Major	Negative	Regional	Irreversible		None	None	None	None
	Death of non-employee	Major	Negative	Regional	Irreversible	- OSH trained personnel present on site at all times	None	None	None	None



## 9. Environmental Monitoring and Management Plan

The basis for compliance monitoring will be the terms of an EMA Certificate of Environmental Clearance. The management plans need to be translated into a language appropriate for General and Particular Environmental Specifications, which will be included in the Conditions and Specifications of the Construction Contracts. It will be the responsibility of the Contractor to implement the mitigation measures associated with these specifications. WASA will retain an overriding audit function of all of its contractor activities, perform additional monitoring, and enforce compliance where needed.

WASA will appoint a designated representative of the Environmental and Regulatory Compliance Unit. This official will be responsible for ensuring the procedures for monitoring and management outlined in the CEC are adhered to for the duration of the project. The significance of the environmental monitoring and management plan is to observe progress of the project and identify any effects which may not have been previously noted.

### 9.1 Environmental Monitoring

Environmental monitoring would be conducted at the initiation of any construction activity of the site. The monitoring will be carried out through the construction phase including decommissioning of abandoned wastewater facilities. The monitoring plan will be employed throughout the operation of the WWTP, lift stations and sewer mains based on the implementation schedule. The recommended monitoring plan is presented in Table 9-1 and Table 9-2 which includes environmental, public, social and health monitoring arrangements.

Environmental monitoring as covers all aspects of the environment which will be affected by the San Fernando Wastewater Project as established in the impact assessment (Section 8). The parameters which will be screened as part of the monitoring plan are:

- Terrestrial and aquatic environment
- Air
- Noise
- Land/Soil

### 9.2 Social Monitoring

Analogous to the environmental monitoring procedures social monitoring will take place throughout all phases of the San Fernando Wastewater Project. The social impact of this project has a higher magnitude when looking at the collection system construction of the project. The following social considerations will be monitored in order to identify any impacts which may have been overlooked and the effect of the project on the particular social environment:

- Odour
- Public Health and Safety
- Traffic
- Archaeology



Apart from the plans outlined in Table 9-1 and Table 9-2, the EMA may also add or remove certain recommendations based on the need or relevance of the monitoring.

## 9.3 Management

Management of the environmental monitoring must be conducted in order to sustain the guidelines required under the monitoring plan and to ensure that the rules under which the CEC was granted are upheld. The subsequent management techniques discussed in this section will be employed to administer environmental sustainability of the San Fernando Wastewater Project.

### 9.3.1 Environmental and Aesthetic Protection Specification

The environmental and aesthetic protection specification is appended in **Appendix H.1** and will be included in the contract documents given to the Contractor assigned to construct the San Fernando WWTP and Collection System. The specification states that the Contractor must prepare an Environmental Management Plan and a Construction Mitigation Strategy which will address impacts and mitigation methods applied in the associated works. The specification ensures that the Contractor protects the natural habitat from the works that may be carried out. The strategy employed follows specific aspects of the ecological and human environment and includes:

- Flora Protection
  - Protection of flora in areas adjacent to WWTP and collection system construction sites.
  - Removal of trees without permission.
  - Protection of designated trees.
  - Stripping of vegetation and topsoil unnecessarily.
- Archaeological Protection
  - Ensuring archaeological experts are present when excavating in areas close to Archaeological Sites.
  - Notification when an artifact is discovered to Archaeological Society.
- Drainage Protection
  - Prevention of construction material from entering watercourses.
  - Prohibiting disposal of material and water with suspended solids into watercourses.
  - Provision of appropriate structures to divert storm water and runoff.
- Erosion and Sedimentation Prevention;
  - Application of soil conservation methods such as mulching, fabric mat and sediment traps.
  - Preparation of an erosion and sediment control plan which will encompass construction sequencing relative to sedimentation, limits of disturbance, stabilisation methods used and location of a stable construction entrance.



- Waste Disposal;
  - Disposal of waste at a designated landfill.
  - Ensuring waste is approved at landfill.
  - Provision of proper containers to transport liquid waste to landfill site.
  - Prevention of dumping or burial of rubbish.
  - Provision of appropriate waste storage bins on construction site.
- Chemical and Fuel Spill Prevention;
  - Approval of all chemicals and fuels used in construction and operation by governing bodies, including obtaining permits if necessary.
  - Reporting of spills and leaks and prompt removal of spilled chemical or fuel.
  - Appropriate disposal of used oil, filter and grease cartridges and lubrication containers.
- Noise Control;
  - Compliance with NPCR where construction will only occur between 7:00 am to 7:00 pm and where the continuous and instantaneous sound level will not exceed 75 dBA and 130 dB, respectively.
  - Equip compressors and gasoline or diesel-operated equipment with silencers to minimise noise.
  - Prohibit vehicles transporting rock, slurry or concrete from public streets between 6:00 pm to 7:00 am on weekdays and anytime on Saturdays, Sundays or public holidays.
- Dust Control;
  - Ensuring site roadways, existing and utility roads are kept in clean, dust-free conditions.
  - Prevention of air pollutants contaminating air when sandblasting by using suitable temporary enclosures.
  - Covering or wetting material that can generate dust particles and air pollutants.

The document also includes details on access to the construction site, as well as parking issues. The procedure by which the Contractor must brief its employees and sub-contractor personnel is also included in the specification.

### 9.3.2 Traffic Control Specification

The traffic control specification will also be a part of the contract documents given to the Contractor (**Appendix G.2**). The employed Contractor will be required under contract to prepare a detailed Traffic Management Plan, prior to commencement of works. This plan covers vehicular traffic, pedestrian traffic and equipment transport. It is expected to comprise of a schedule of temporary road closures, and the appropriate detours to be used. The specification also outlines details of the objectives of the plan including minimising disruption to business, minimizing dust generated and delay to public transport.

A Traffic Control Committee will have to be appointed before works begin, it will comprise of the following personnel;



- Traffic Manager (appointed by the Contractor)
- Engineer
- Employees Representative (appointed by WASA)
- Representative of San Fernando City Corporation and Princes Town and Penal/Debe Regional Corporations.
- Representative of Highways Division of MOWT
- Police Officer of the Traffic Branch

The committee is expected to supervise as well as consult with residents and stakeholders to determine the convenience of the traffic management schedule.

Another significant detail of the Traffic Control Specification is implementation by the Contractor of traffic signs and other signals which should give notice or warn of;

- Construction activities ahead and restriction of roadway to local traffic only.
- Diversion of traffic from one-way travel roads at cross-streets and back lanes.
- Unpaved trenches and disturbed pavement areas by installing flashing light barricades.
- Drop off of pavement greater than 8 cm but less than 16 cm within 2.5 m of edge by using mono-directional steady burn lights.
- Drop off of pavement greater than 8 cm but less than 60 cm within 2.5 m of edge by using barricades.

The Contractor is also responsible for replacing permanent traffic signs that may have been blocked as a result of construction with temporary signs. All signs and barricades installed must be maintained to ensure eligibility and that it is within the appropriate location, all of the sign structures must be removed when construction ceases.

The Traffic Control Specification highlights the major roadways that will be affected by the San Fernando Wastewater Project and the particulars of the detour roads that can be used to divert traffic from these roadways including the dimensions of the largest possible vehicle that can utilize these detour roads. The document details of vehicular, pedestrian and construction equipment traffic the operations of vehicular traffic during working and non-working periods is also discussed. Compliance with the traffic regulations of Trinidad and Tobago and the guidelines of the Traffic Control Specification must be followed by the Contractor, Engineer and Employer of the San Fernando Wastewater Project.

### 9.3.3 Waste Management Plan

A specific waste management plan will be formulated preceding construction activities to identify the waste that would be generated as a result of the establishment of the San Fernando Wastewater Project (**Appendix H.3**). The plan would highlight reuse procedures and proper storage and disposal of waste. The waste from the construction of the WWTP and lift stations will be disposed of at a designated landfill site closest to the works. In the San Fernando area, the closest landfill is the Forres Park Landfill in Claxton Bay which is operated by the Solid Waste Management Company Limited (SWMCOL). Waste will be segregated and stored in designated storage areas before it is transported to the landfill.





The waste management during installation of the sewer mains will comprise of using the excavated material to backfill and seal the trench after the pipes are laid. Other wastes that cannot be reused to fill the trench will be disposed of using the same approach as that of the WWTP and lift stations.

The clearing of waste would be supervised by a qualified official employed by the Contractor to ensure that waste is disposed of according to the guidelines set out in the Waste Management Plan and in adherence of the Waste Management Rules, 2008.

### 9.3.4 Mitigation Action Plan

The mitigation measures discussed in Section 8 will be implemented in the appropriate project phases. It will be the responsibility of the Contractor employed by WASA to carry out the construction works as well as the Engineer hired by WASA to supervise the works to ensure that the contract is followed. The mitigation measures outlined in Table 8-4 and Table 8-5 will be transferred into specifications to be included in the San Fernando Wastewater Contract documents.

### 9.3.5 Emergency Response Plan

The possibility of the natural hazards that will affect the project area is clearly implied from the physical baseline assessment described in Section 5.3. An emergency response plan will need to be formulated by the Contractor according to the contract specifications in order to ensure the impact of a disaster is minimised or prevented. The emergency response plan will take effect prior to commencement of construction works and will be upheld throughout the operation of the San Fernando Wastewater Facilities. The plan will incorporate the response to both natural disasters and chemical spills. The importance of ensuring a disaster is prevented is asserted by the fact that sewer collection and treatment is considered a public utility.

The emergency response plan will incorporate:

- Hazard identification
- Emergency resources
- Communication systems
- Administration of the emergency response plan
- Emergency response procedure
- Communication of the procedure

## 9.4 Compliance

Compliance of the environmental monitoring and management plans is crucial to the success of the project. The Contractor will be responsible for appointing a staff to implement and oversee monitoring and management arrangements, including but not limited to:

- Traffic Control Committee
- Health and Safety Advisors
- Emergency Response Team
- Public Relation Officers



The Engineer hired by WASA to administrate the terms of the contract will be responsible for ensuring guidelines are followed and any appropriate modifications are made. The environmental monitoring will be supervised by the Environmental and Regulatory Compliance Unit at WASA.

The procedure to be followed in the event of non-compliance is immediate written notification of the breach of the terms of contract by the Engineer to the Contractor. If the notification is not regarded, a Notice of Violation will be presented to the Contractor by the Engineer clearly expounding the infringement and the procedures to be followed to uphold the contract. Where the Contractor rejects the Notice, the Engineer will inform WASA of the breach upon which disciplinary action will be taken. The disciplinary action may be a fine or even termination of the contract. The overall obligation of compliance of the environmental monitoring and management and all the terms of the CEC is the duty of WASA, through receipt of the CEC.



**Table 9-1 Monitoring Plan – Construction Phase**

Theme	Issue	Activity	Suggested Frequency	Responsibility of
Contract	Technical Specification Compliance	Audit and ensure compliance with contract specifications, CEC provisions, and worker health and safety.	Daily	Engineer
	River Water Quality	Visual inspection at construction sites for runoff, solid deposits or oil sheen on nearby watercourses	Daily	WASA
Monitor turbidity levels in watercourses next to construction sites		Coincide with excavation works		
Physical Environment	Air Quality	Conduct TSP monitoring in communities where construction is occurring, including WWTP site. Sampling stations to be at: Site of works Nearest receptors to north, east, south, west within 1 km.	Monthly	WASA
		Conduct SPL, Leq, and Lpeak monitoring in communities where construction is occurring, including WWTP site. Sampling stations to be at: Site of works Nearest receptors to north, east, south, west within 1 km.	Monthly	WASA



**Table 9-1 Monitoring Plan – Construction Phase (continued)**

Theme	Issue	Activity	Suggested Frequency	Responsibility of
Social Environment	Traffic	Install and adhere to Traffic Control Plan.	Daily	Contractor
	Infrastructure	Ensure damage to adjacent properties is prevented. In the case of damage incidence recorded and financial compensation given.	Incidental	Contractor
	Utilities	Ensure there is no destruction to utilities. Representative from utility companies must be present at excavation site.	Incidental	Contractor
	Archaeology	In cases where archaeological site is in close proximity to earthworks arrange for member of Archaeology Society to be present. Where earthworks will be undertaken at archaeological site, excavate site prior to construction.	Incidental	Contractor
	Public Health, Safety and Social Concerns	Record all complaints received from the general public regarding dust, noise, traffic, property access and odours.	Incidental	Contractor

**Table 9-2 Monitoring Plan – Operation Phase**

Theme	Issue	Activity	Suggested Frequency	Responsibility of
Contract	WWTP and Collection System Equipment	Ensure schedule maintenance of equipment	Incidental	WASA
	Effluent Discharge Quality	Conduct testing of effluent discharged to receiving environment from WWTP. Conduct testing for BOD, TSS, DO, temperature, Faecal Coliform and pH	Weekly	WASA
Physical Environment	Aquatic Environment	Monitor Faecal Coliform counts at strategic sample points; before and after effluent discharge pipe.	Yearly	WASA
	Land/Soil/Groundwater	Regular checks of sewer mains and manholes via CCTV monitoring.	Yearly	WASA
	Odour	Maintain odour control equipment.	Quarterly	WASA
Social Environment	Noise	Conduct SPL, Leq, and Lpeak monitoring on boundary of WWTP site.	Quarterly	WASA
	Health and Safety	Conduct regular checks to ensure health and safety regulations are adhered to on-site Conduct effluent monitoring as indicated in Physical Environment section above.	Daily	WASA
	Public Concerns	Record all complaints received from the general public regarding operation of the WWTP, collection system, or lift stations.	Incidental	WASA



## 10. Bibliography

- Anonymous. (1999). *Conservation of Wildlife*. Port of Spain, Republic of Trinidad and Tobago: Legal Supplement Part C to the Trinidad and Tobago Gazette, Vol. 38, No. 34, 24th February, 1999. Printed by the Government Printer.
- Beard, J. (1946). *The Natural Vegetation of Trindiad*. Oxford: Clarendon Press.
- Central Statistical Office. (2002). *2000 Population and Housing Census: Community Register*. POS: The Ministry of Planning and Development.
- Comeau, P. (2010). *San Fernando Wastewater Project: Botanical Component*. St. Augustine.
- Construction Safety Association of Ontario. (2003). *Emergency Response Planning for Construction Projects*. Ontario.
- County of San Mateo. (2010, May). *Waste Management Plan*. Redwood City, California, USA.
- Donovan, S. (1994). *Caribbean Geology: Trinidad*. Kingston: U.W.I. Publishers Association.
- Environmental Management Authority. (2009, September). *National Environmental Policy*. Retrieved November 2009, from Environmental Management Authority:  
[http://www.ema.co.tt/cms/images/stories/pdf3/nep%2019sept05%20final%20ema%20edit%20changes%20accepted%20\(24sep09\)%20\(2\).pdf](http://www.ema.co.tt/cms/images/stories/pdf3/nep%2019sept05%20final%20ema%20edit%20changes%20accepted%20(24sep09)%20(2).pdf)
- French, R. (1997-1998). Doubtful origin in some bird species recorded in Trinidad and Tobago. *Living World, J. Trinidad & Tobago Field Naturalist's Club*, 8-12.
- Genivar. (2009). *WASA Water and Wastewater Master Plan and Policy Development*. POS: WASA.
- Marshall, R. (1934). *Physiography and vegetation of Trinidad and Tobago - a study in plant ecology*. Oxford Forest.
- Metcalf & Eddy Inc. (1991). *Wastewater Engineering: Treatment, Disposal, Reuse (Third Edition)*. USA: McGraw-Hill.
- Metcalf, E. (2003). *Wastewater Engineering: Treatment and Reuse: 4th Edition*. New York, N.Y.: The McGraw-Hill Companies.
- Minister of National Health and Welfare. (1992). *Guidelines for Canadian Recreational Water Quality*. Minister of National Health and Welfare.
- Ottley, C. (1971). The Ciperó Tramway. In *The Story of San Fernando*. POS.
- Storm CARIB Caribbean Hurricane Network. (n.d.). Retrieved April 27, 2010, from [www.stormcarib.com](http://www.stormcarib.com): [http://stormcarib.com/climatology/TTPP\\_all\\_isl.htm](http://stormcarib.com/climatology/TTPP_all_isl.htm)



Temple, S. (2002). Extinction-prone birds of Trinidad and Tobago: making predictions from theory. *Studies in Trinidad and Tobago Ornithology Honoring Richard ffrench.* , 180-193.

The Energy Chamber of T&T. (n.d.). *www.energy.tt*. Retrieved May 4, 2010, from The Energy Chamber: <http://www.energy.tt/index.php?categoryid=156>

*The University of the West Indies Seismic Research Centre*. (n.d.). Retrieved April 28, 2010, from [www.uwiseismic.com](http://www.uwiseismic.com): <http://www.uwiseismic.com/NewsDetails.aspx?id=155>

Trinidad Guardian. (1998, November 18). The History of San Fernando. p. 13.

*U.S. Environmental Protection Agency*. (n.d.). Retrieved April 30, 2010, from [www.epa.gov](http://www.epa.gov): <http://www.epa.gov/airtrends/aqtrnd95/pm10.html>

*UN Statistics Division*. (n.d.). Retrieved May 7, 2010, from <http://unstats.un.org>: <http://unstats.un.org/unsd/environmentgl/gesform.asp?getitem=936>

United Nations Food and Agriculture Organization. (2010). *Fisheries and Aquaculture Department*. Retrieved 05 13, 2010, from Country Profile, Trinidad & Tobago: [http://www.fao.org/fishery/countrysector/FI-CP\\_TT/en](http://www.fao.org/fishery/countrysector/FI-CP_TT/en)

Water Resources Agency. (2010, April 30). River Flow Data for Ciperó River.

Weather Underground Inc. (n.d.). *www.wunderground.com*. Retrieved April 12, 2010, from <http://www.wunderground.com/history/airport/TTPP/2010/4/26/CustomHistory.html>

White, G. (2009). *Habitats and Fauna of the San Fernando Wastewater Catchment Area*. Trinidad.

Wilkes University, Environmental Engineering and Earth Science Department. (n.d.). *Nitrogen - Ammonia in Water*. Retrieved May 12, 2010, from <http://www.water-research.net/Watershed/ammonia.htm>

World Health Organization. (2003). *Guidelines for Safe Recreational Water Environments: Volume I Coastal and Fresh Waters*. Geneva.



## Statement of Qualifications and Limitations

The attached Report (the “Report”) has been prepared by AECOM Canada Ltd. (“Consultant”) for the benefit of the client (“Client”) in accordance with the agreement between Consultant and Client, including the scope of work detailed therein (the “Agreement”).

The information, data, recommendations and conclusions contained in the Report (collectively, the “Information”):

- is subject to the scope, schedule, and other constraints and limitations in the Agreement and the qualifications contained in the Report (the “Limitations”)
- represents Consultant’s professional judgement in light of the Limitations and industry standards for the preparation of similar reports
- may be based on information provided to Consultant which has not been independently verified
- has not been updated since the date of issuance of the Report and its accuracy is limited to the time period and circumstances in which it was collected, processed, made or issued
- must be read as a whole and sections thereof should not be read out of such context
- was prepared for the specific purposes described in the Report and the Agreement
- in the case of subsurface, environmental or geotechnical conditions, may be based on limited testing and on the assumption that such conditions are uniform and not variable either geographically or over time

Consultant shall be entitled to rely upon the accuracy and completeness of information that was provided to it and has no obligation to update such information. Consultant accepts no responsibility for any events or circumstances that may have occurred since the date on which the Report was prepared and, in the case of subsurface, environmental or geotechnical conditions, is not responsible for any variability in such conditions, geographically or over time.

Consultant agrees that the Report represents its professional judgement as described above and that the Information has been prepared for the specific purpose and use described in the Report and the Agreement, but Consultant makes no other representations, or any guarantees or warranties whatsoever, whether express or implied, with respect to the Report, the Information or any part thereof.

The Report is to be treated as confidential and may not be used or relied upon by third parties, except:

- as agreed in writing by Consultant and Client
- as required by law
- for use by governmental reviewing agencies

Consultant accepts no responsibility, and denies any liability whatsoever, to parties other than Client who may obtain access to the Report or the Information for any injury, loss or damage suffered by such parties arising from their use of, reliance upon, or decisions or actions based on the Report or any of the Information (“improper use of the Report”), except to the extent those parties have obtained the prior written consent of Consultant to use and rely upon the Report and the Information. Any damages arising from improper use of the Report or parts thereof shall be borne by the party making such use.

This Statement of Qualifications and Limitations is attached to and forms part of the Report and any use of the Report is subject to the terms hereof.





## Executive Summary

### 1. Project Introduction and Background

The Water and Sewerage Authority of Trinidad and Tobago (WASA) are proposing to expand and upgrade the wastewater infrastructure in San Fernando and Environs to improve the level of service for existing and new customers. The end result of the project will be an integrated wastewater system that provides a cost-effective and sustainable solution to wastewater collection, treatment and disposal for San Fernando and Environs that significantly improves the water quality in rivers and surrounding environment, protects public health and improves the quality of life for the residents. The relevance and urgency of the project is made more evident with the knowledge that this entire region continues to undergo rapid industrial and commercial development as well as population growth.

The main benefits of the project include:

- Reduction in public health risk associated with untreated wastewater discharges into drains, rivers and other water courses.
- Improvement of water quality in the Guaracara, Marabella, Vistabella and Cipero Rivers that currently receive wastewater discharges.
- Overall improvement to the surrounding environment through the proper collection, treatment and disposal of wastewater that is otherwise presently adversely impacting the environment.
- Potential for production of up to 45 mega litres per day (ML/d) of reclaimed water that is suitable for irrigation and other non-potable uses in the area.
- Overall improvement in the quality of life for citizens of San Fernando and Environs.

The San Fernando Wastewater project involves the establishment of a new wastewater treatment plant (WWTP) centrally located at the existing San Fernando WWTP site, the integration of existing sewers into a centralized collection system, and the provision of new sewers to service all un-sewered properties within the wastewater catchment area.

An overview of the San Fernando Wastewater project area, showing the location of the San Fernando WWTP, the project boundaries, watercourses and major roads, is illustrated in Figure 1. Figure 2 displays all existing WWTPs and sewerage areas within the San Fernando Wastewater project area.

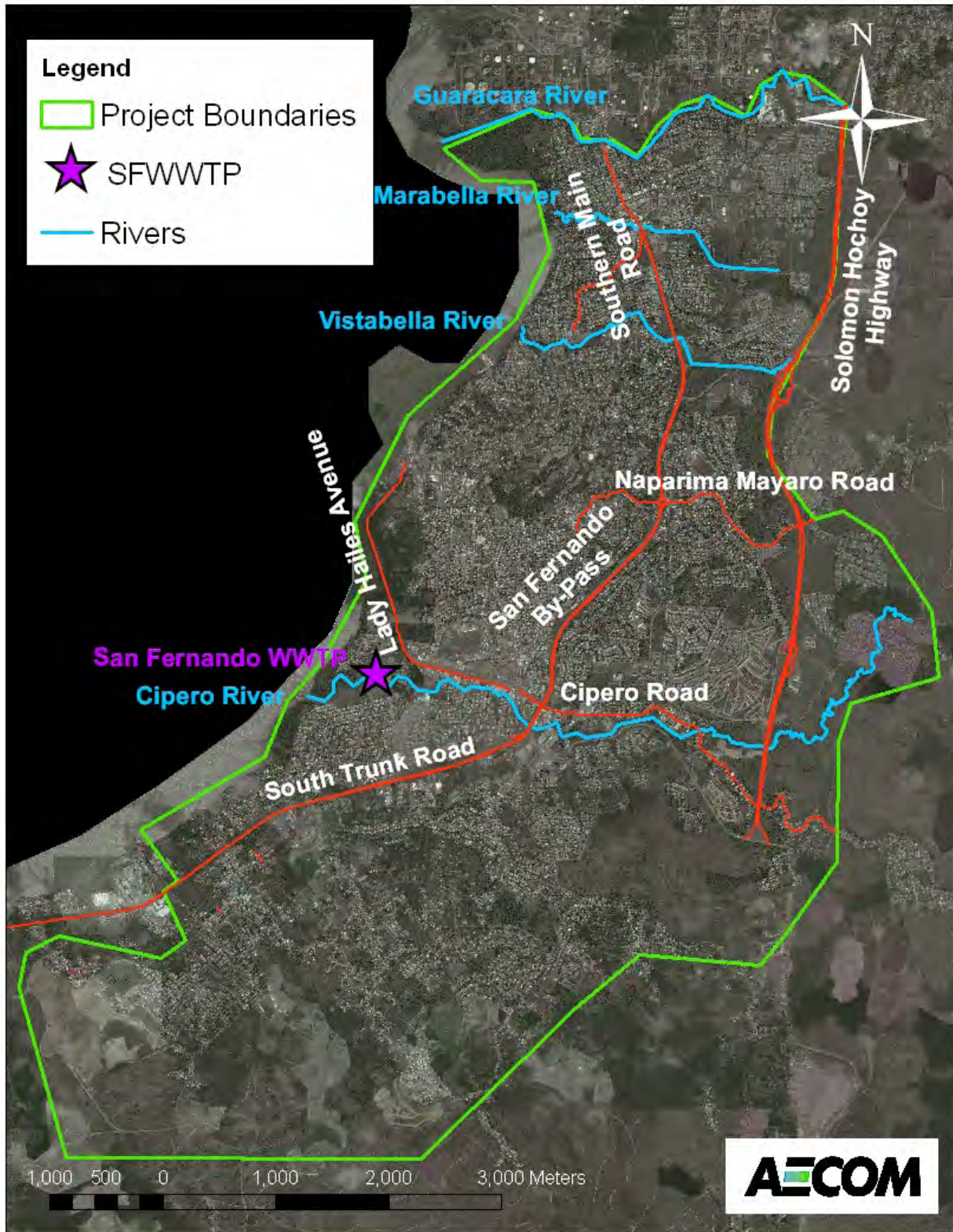


Figure 1 San Fernando Wastewater Catchment Area



Figure 2 Existing Sewered Areas (shaded) and WWTPs in San Fernando Project Area



The new WWTP is to replace all nine existing plants within the project boundaries. The plants being eliminated are:

- San Fernando WWTP
- Harmony Hall WWTP
- Palmiste WWTP
- Gulf City Development WWTP
- Sunkist WWTP
- Westpark WWTP
- San Fernando Technical Institute WWTP
- Marabella Secondary School WWTP
- Corinth Housing Development Retention Pond

The main objectives of the San Fernando Wastewater Project are:

- Identify the most effective arrangement of the wastewater systems within the City of San Fernando and Environs from a technical, operational and financial perspective.
- Prepared detailed design, cost estimates, implementation schedules and tender documents for the rehabilitation and expansion of the wastewater collection system within the San Fernando Wastewater Catchment area.
- Prepare detailed designs, cost estimates, implementation schedules for the construction of a central WWTP.
- Design the new WWTP to ensure the effluent complies with the Water Pollution Rules, 2001 (as amended).
- Design the new WWTP with the provision to produce an effluent suitable for reuse in agricultural irrigation, industrial uses and indirect augmentation of potable water supplies.
- Design the collection system and treatment facility to a design horizon of 2035.

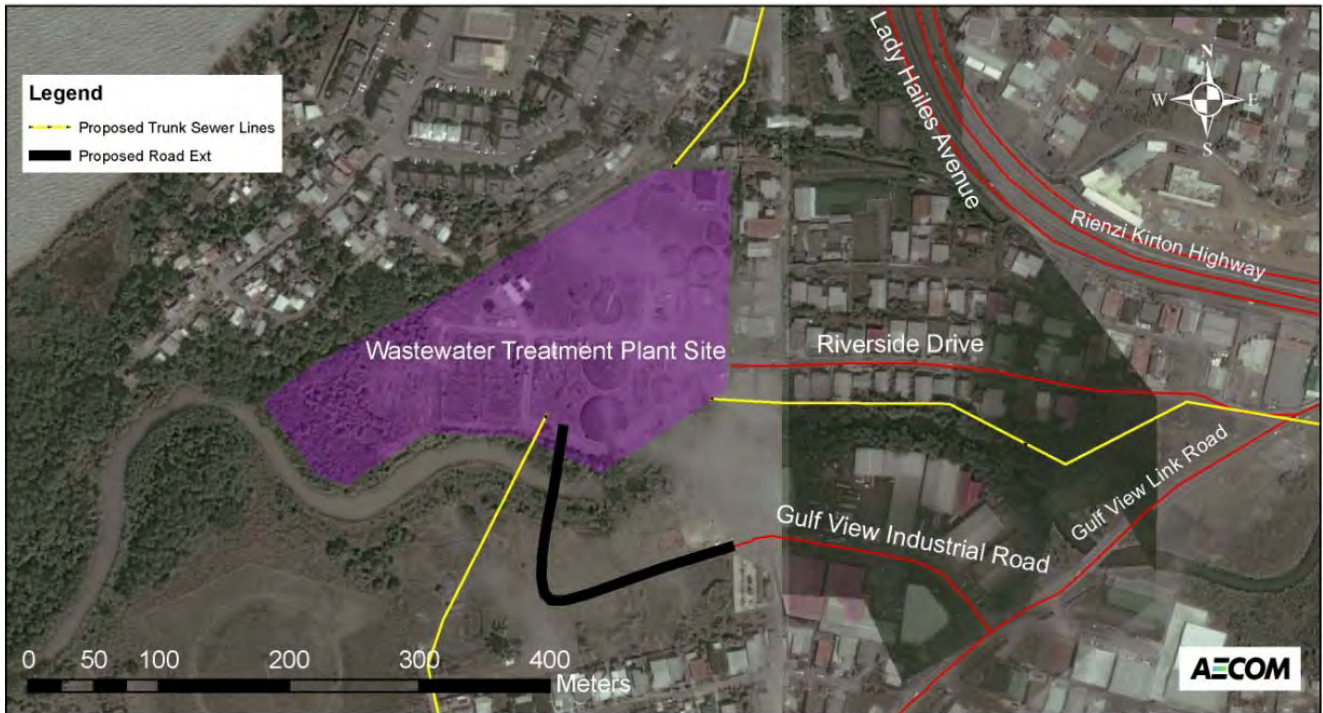
## 2. Existing Situation

The City of San Fernando is currently serviced by a wastewater collection, treatment and disposal system built in the 1960s and owned and operated by WASA. The collection system has approximately 72 km of piping and services an estimated 25,000 people in San Fernando proper. The existing San Fernando WWTP was designed to handle a wastewater flow of 20 ML/d. A septage receiving station was added in the 1980s.

The areas outside of the existing San Fernando collection system have experienced significant development over the past several years. Some of the planned housing developments built since 1970 have installed sewers and package WWTPs that are operated either privately or, in the case of HDC developments, have been taken over by WASA in recent years. Over time, most of these facilities have fallen into a state of disrepair or have been abandoned. Approximately 70% of the developed areas are serviced by individual on-lot disposal systems, the majority of which are either partially functioning or not at all. Water quality testing of the four main rivers running through the project area has verified high levels of faecal coliform bacteria, which is an indicator organism for raw wastewater contamination.

### 3. Project Description

The San Fernando Wastewater project comprises a centralized and integrated sewer collection system and a single WWTP. All wastewater will be conveyed to the new San Fernando WWTP located at the end of Riverside Drive, Gulf View at the site of the existing San Fernando WWTP (Figure 3). A new alternative access road to the site is proposed through the Gulf View Industrial Park. The new treatment plant will be constructed where the existing plant structures are located and extending west. All the land is currently occupied and owned by WASA.



**Figure 3 Existing and Proposed WWTP Site**

#### 3.1. Wastewater Treatment Plant

The design effluent criteria for the WWTP is based on treating the wastewater to meet US EPA Guidelines for Water Reuse and California and Florida state regulations governing reclaimed water. The new plant will be capable of producing consistently high quality effluent that can be safely re-used for agricultural irrigation, and industrial uses. In the event that the treated effluent is not reclaimed it will be discharged to the Ciperu River. These standards exceed those stipulated in the EMA Water Pollution Rules 2001 (as amended) for Inland Surface Water Discharges (Table 1).

**Table 1 San Fernando WWTP Effluent Criteria**

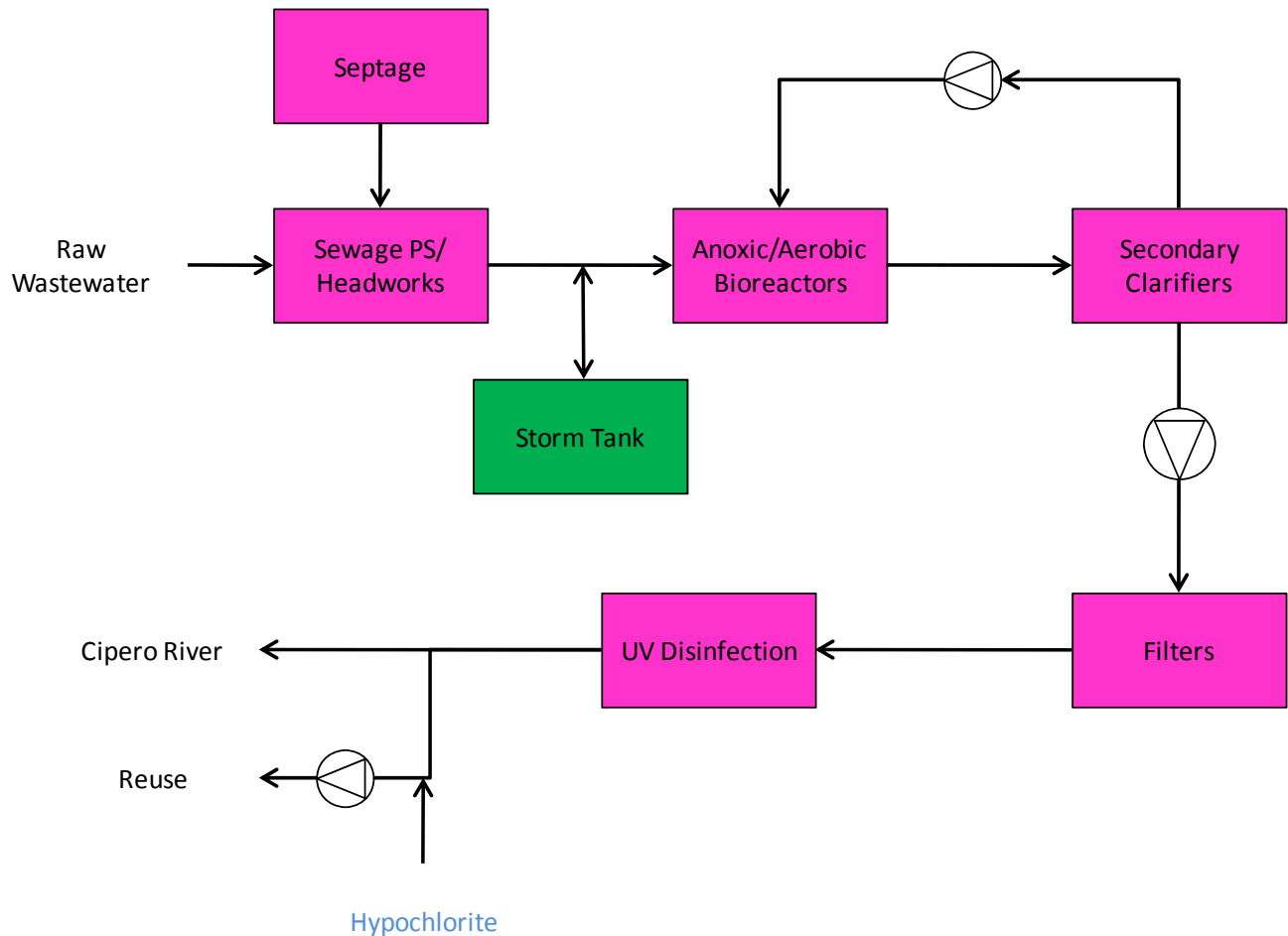
Parameter	EMA Water Pollution Rules 2001 (as amended) for Inland Surface Water Discharge	Design Effluent Criteria
BOD (mg/L)	30	< 20(CBOD)
TSS (mg/L)	50	< 5
Dissolved Oxygen (mg/L)	> 4	> 4
Temperature °C	< 3	< 3
Ammonia-Nitrogen (mg/L)	10	< 10
Total Nitrogen (mg/L)	-	< 15
Total Phosphorus (mg/L)	< 5	< 5
Faecal Coliform (CFU/100ml)	400	Max: 25/100 mL and 75% samples below detection
pH	6-9	6 to 8.5
Total Residual Chlorine (mg/L)	1	<1

The WWTP will be sized to treat the 2035 design year average dry weather flow (ADWF) of 45 ML/d and peak dry weather flow (PDWF) of 90 ML/d through secondary and tertiary treatment. The influent pump station, influent screens and grit removal facilities (headworks) will be capable of handling the design peak wet weather flow (PWWF) of 158 ML/d. Flows in excess of the PWWF will be diverted to storm water storage facilities on-site until secondary treatment capacity is available. Treated effluent will be either re-used beneficially or discharged to the Ciperu River. Screenings and grit will be washed, dewatered and hauled off site for disposal in a landfill. Waste solids from the activated sludge treatment process will be aerobically digested, dewatered, and hauled off site for beneficial use or landfill disposal.

The treatment scheme of the liquid stream includes the following unit processes:

- Influent pumping
- Septage receiving
- Fine screening
- Grit removal
- Storm water storage
- Activated sludge aeration (Bioreactors)
- Secondary clarification
- Return activated sludge (RAS) pumping
- Filtration
- UV disinfection
- Chlorination (if reused)

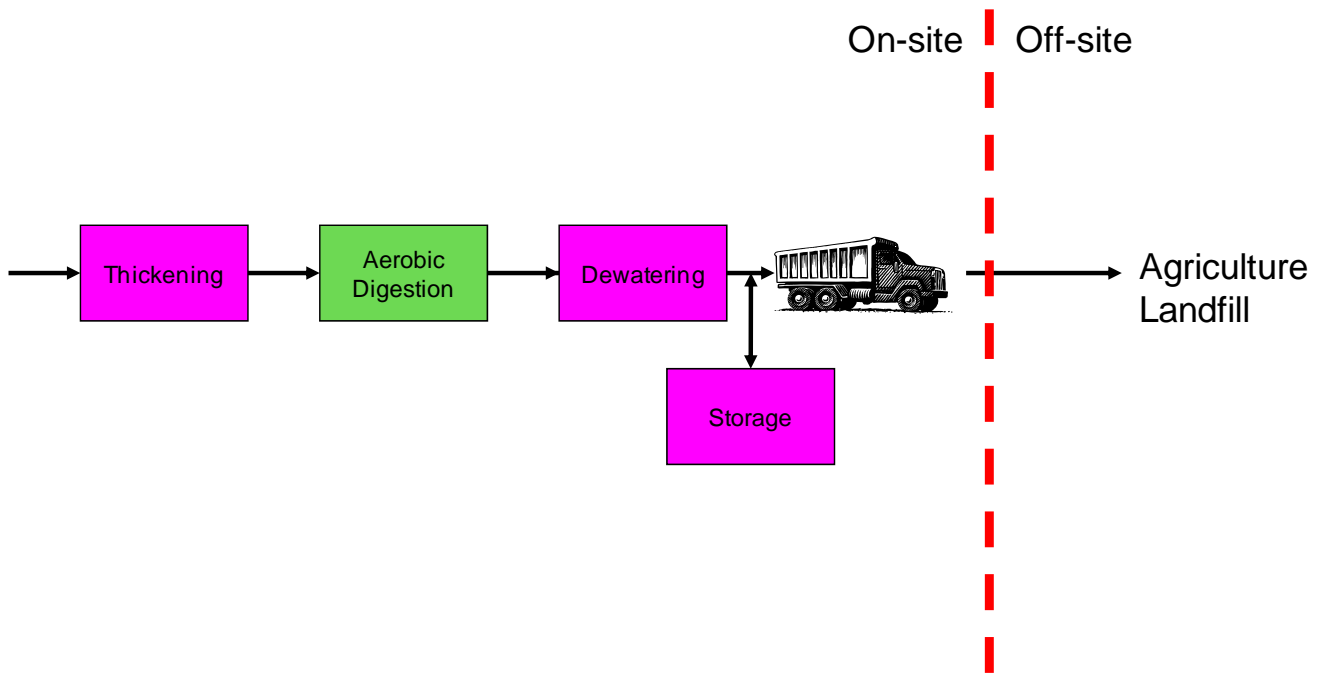
The liquid stream flow schematic is illustrated in Figure 4.



**Figure 4 WWTP Liquid Stream Flow Schematic**

The waste solids from the liquid treatment process scheme will be treated to meet WASA requirements as defined to be suitable for beneficial reuse as agricultural land application. The treatment involves the waste activated sludge being thickened and then aerobically digested. The digested solids will be dewatered and hauled off site.

The existing anaerobic digesters will be converted to aerobic digesters. The dewatering facility will consist of a two-story building with belt filter presses located on the second floor. The lower level will be an open area for loading trucks. The facility will also include polymer storage, mixing and feed equipment. Temporary storage of the dewatered cake will be provided on-site in covered trailers. The dewatered cake will be taken off-site for either agricultural land application or landfilled. A flow schematic of the solids process is illustrated in Figure 5.



**Figure 5 WWTP Solid Stream Flow Schematic**

### 3.2. Collection System

The extent of the collection system for the San Fernando Wastewater Project is defined by the San Fernando regional wastewater catchment boundaries. The regional catchment was established in 2008 as part of WASA’s wastewater master plan to divide the country into a number of regional catchments for servicing. The boundaries of the San Fernando regional catchment were refined under the present project through an extensive field investigation programme with inputs from WASA, TCPD, San Fernando City Corporation, and other relevant stakeholders. The San Fernando regional catchment covers an area of 42 km<sup>2</sup> and the boundaries are depicted in Figure 1.

The San Fernando regional catchment is divided into a number of subcatchments based on the following characteristics:

- Natural topography
- Drainage
- Physical boundaries

Dividing the entire catchment into a number of smaller sub-catchments allows for a phased implementation of the project based on availability of financing, cash-flow constraints and also allows prioritization of serviced areas to optimize the environmental benefits over the period of execution. The subcatchment boundaries are illustrated in Figure 6.





Figure 6 Subcatchments of the San Fernando Wastewater Project



The proposed wastewater collection system consists of a gravity sewer system with pipe sizes ranging from 200 mm to 1500 mm diameter. The sewers collect all wastewater from the project area and convey it to the new WWTP. When the depth of the gravity sewer exceeds the design limit, a wastewater lift station is introduced to pump or “lift” the wastewater back up to a higher level. The main objectives of the collection system design included:

- Sewer all properties within the project area.
- Minimize the amount of pumping so as to reduce the level of maintenance required to operate and maintain the system.
- Minimize disruption through the use of trenchless technology for the larger trunk sewers, major road crossings, river crossings and congested areas.

The proposed San Fernando collection system is illustrated in Figure 7. A summary of the proposed sewer pipe lengths per subcatchment is shown in Table 2.

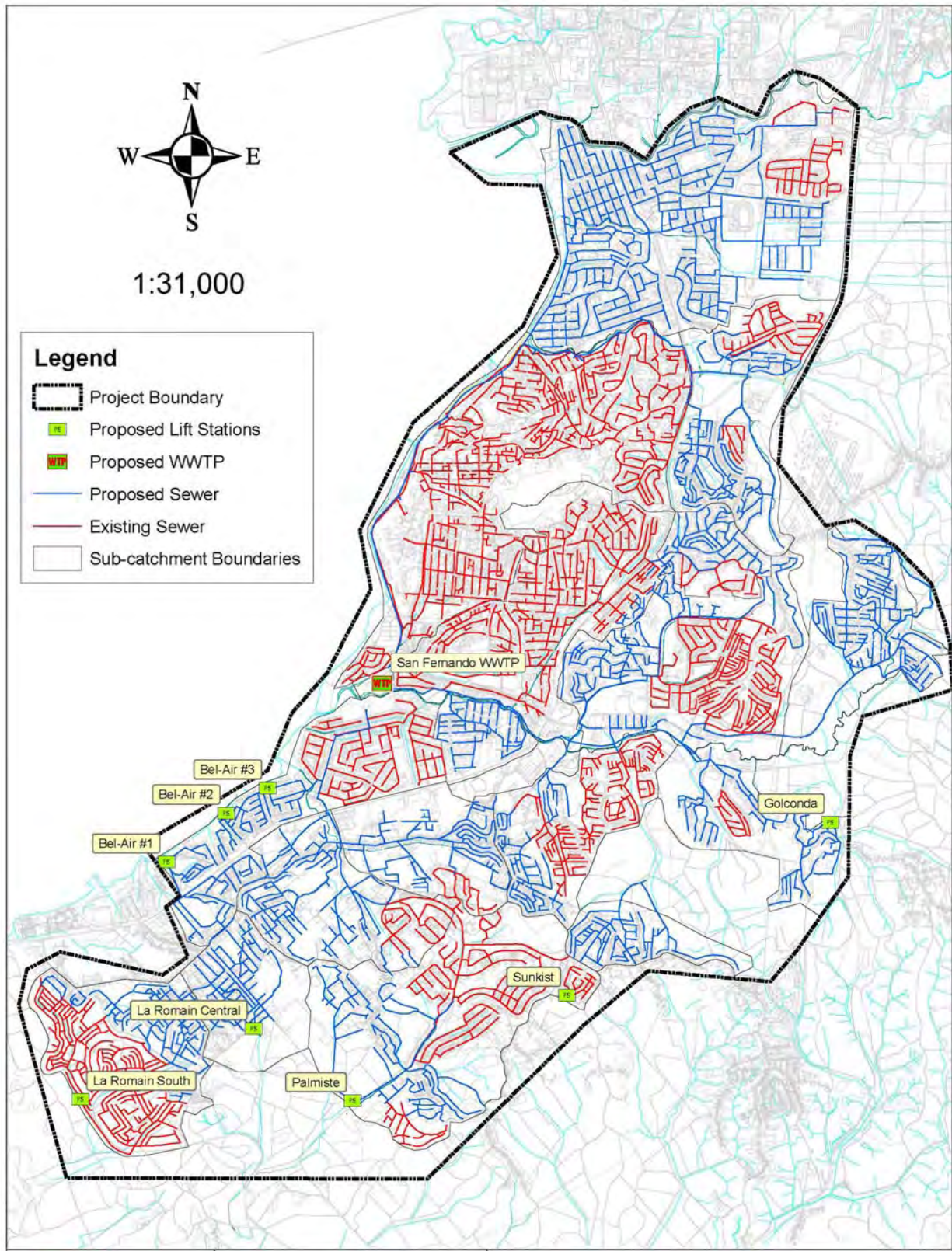


Figure 7 Proposed San Fernando Wastewater Collection System

**Table 2 Proposed Collection System Pipe Length by Subcatchment**

Subcatchment	Pipe Length (km)
Marabella	48
Tarouba-Cocoyea	16
Cocoyea South	7
Pleasantville-Corinth	16
Vistabella-Gulf	6
San Fernando South	4
Ste. Madeleine	18
Bel Air - Gulf View	13
Green Acres	6
Duncan Village	11
Union Hall	8
Retrench-Golconda	11
La Romain North	15
La Romain Central	11
La Romain South	11
Palmiste South	13
Picton	9
<b>Total New Sewer</b>	<b>224</b>

### 3.3. Construction Phasing of Project

The San Fernando project will most likely be constructed in phases to accommodate operation of existing facilities, minimize disruption in the community, and match funding capabilities. The primary objective is to achieve maximum benefit during the first phase of construction by building the new WWTP and connecting areas with existing sewers.

The proposed Phase I would consist of two construction contracts (Figure 8) as follows:

- Contract No. 1 – New San Fernando WWTP
- Contract No. 2 – Trunk sewers constructed using trenchless techniques plus connecting sewers between existing sewer areas and the new trunk lines.

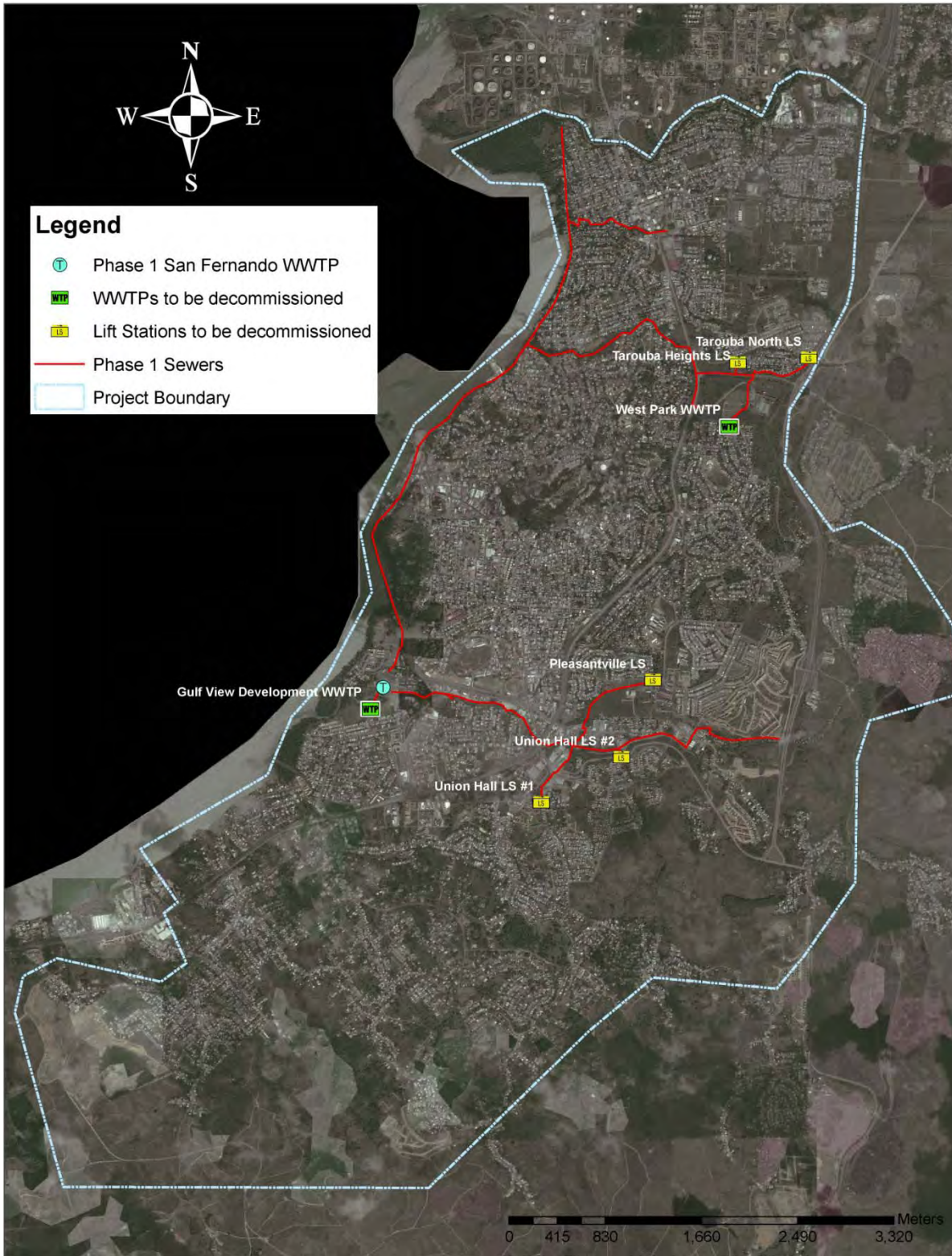


Figure 8 Phase I Construction Contract: WWTP and Collection System



At completion of Phase I, wastewater entering the existing San Fernando sewer system and most of the sewered areas that naturally drain to the Cipero River would be treated in the new WWTP. The initial ADWF to the plant would be approximately 16 ML/d, which is 36 percent of the ultimate design ADWF of 45 ML/d. This equates to a service population of 40,035 out of a total 2035 population of 111,600.

The remainder of the collection system construction will be prioritized and phased based on the available funding. The first priority would be to construct the trunk sewer from the WWTP, south through Gulf View to Dumfries Road, and south along Dumfries Road to Palmiste Avenue. Completion of this trunk sewer would provide conveyance capacity to connect all the subcatchments located south of the Cipero River. Priorities would be assigned based on several factors including connection of existing sewered areas, e.g., Palmiste South; environmental issues such as anticipated water quality improvement; and construction costs.

#### 4. Environmental Impact Assessment Report

An application for a Certificate of Environmental Clearance (CEC) for this project was submitted to the Environmental Management Authority (EMA) in August 2006 in accordance with CEC Rules 2001. The EMA determined that the application required an Environmental Impact Assessment (EIA) study to assist in its determination of the application since the project was considered to have the potential for environmental and social impacts. The Final Terms of Reference (TOR) for the EIA in support of WASA's application (CEC 1597/2006), were provided to WASA on 21 November 2006. AECOM Canada Limited was commissioned by WASA in March 2008 to conduct an EIA in accordance with the Final TOR issued by the EMA, and to carry out detailed designs for the San Fernando Wastewater Project.

The objective of an EIA is to:

- Provide information which allows developers to maximize benefits of the project to themselves, the environment and local and national community.
- Allow regulators to ensure that the positive impacts of the project are maximized and the negative impacts eliminated or minimized to acceptable levels.
- Allow the community and the wider public to gain an understanding of the project and its impacts on them and their socio-economic and physical environment, and to have their views and concerns addressed.

This EIA report consists of one volume containing the main text and a second volume containing a number of appendices which documents a detailed description of the biophysical and social environment in which the WWTP and collection system will be constructed and operated. The EIA report lists the potential impacts each component of the project will have on the environment. These impacts were assessed and the most appropriate mitigation measures were determined and incorporated in the design of the San Fernando WWTP and collection system. An environmental monitoring and management plan was also developed as a means of prevention, minimisation and remediation of any impacts the San Fernando Wastewater Project may have on the biophysical and human environment.



#### 4.1. Baseline Biophysical and Social Environment

The biophysical environment is largely influenced by anthropogenic activities including agriculture, industry and residential and commercial development. Few natural areas remain within the project boundaries. The remaining undeveloped areas are categorised as low vegetation with scrub, agricultural, and forested areas.

Water quality testing was carried out on the Ciperó, Guaracará, Marabella, Vistabella Rivers, and Alley's Creek to assess the effects of the existing situation on the receiving rivers and streams in the San Fernando wastewater catchment. The results of the water quality testing programme indicated high levels of faecal coliforms in the rivers (Table 3). The presence of faecal coliform is a strong indicator of raw sewage and the concentrations measured were indicative of significant wastewater discharges in most of the rivers in the San Fernando wastewater catchment. The Ciperó River had the highest concentration of faecal coliform out of all the rivers tested. Faecal coliform levels were also generally higher in the wet season sampling event.

**Table 3 Fecal Coliform Data (CFU/100ml) from River Quality Sampling**

River Name	Dry Season (June 3, 2009)	Wet Season (October 20, 2009)	EMA WPR First Schedule Quantity Defined as a Pollutant
Guaracará	Inland – 360	Inland – 8,000	>100
	Gulf – 315	Gulf – 32,000	
Marabella	Inland – 8,000	Inland – 11,000	
	Gulf – 49,000	Gulf – 46,000	
Vistabella	(River Dry)	Inland – 11,000	
		Gulf – >200,000*	
Ciperó	Inland – 179,000	Inland – 198,000	
	Gulf – 120,000	Gulf – >200,000*	
Ally's Creek	(River Dry)	112,000	

Note: \* - too numerous to count (TNTC)

Flora and fauna studies were conducted and a land use category map was developed to assist in the studies. The results indicate over 60% of the project area is currently developed by human activities (Table 4).

**Table 4 Land Use Categories in San Fernando Wastewater Catchment**

Land Use Category	Area (km <sup>2</sup> )	Percentage of Study Area (%)
Commercial and Residential	8.07	49
Low Density Buildings	0.88	5
New Developments	1.16	7
Abandoned Sugarcane	0.99	6
Scrub and Agriculture	3.63	22
Mangrove Forest	0.21	1
Riparian Forest	0.16	1
National Parks	0.21	1
Close Cropped Lawns	0.49	3
Other	0.8	4
<b>TOTAL</b>	<b>16.6</b>	<b>100</b>

Upon examination of the flora habitat it was recommended that the natural remnants of mangrove and riparian forest be preserved. During fauna studies, a total of 84 bird species were observed in the fauna study and a few vertebrate populations. Based on the research conducted it was concluded that some vulnerable and rare species can visit the project area. A fish survey conducted in the rivers and in the coastal waters surrounding the San Fernando Wastewater catchment area found Guppies, Black Tilapia, Catfish and Mullet. It is likely that the poor water quality in the rivers is contributing to the relatively low diversity of fish species found as compared to other rivers in Trinidad. Table 5 summarizes this data.

**Table 5 Fauna Survey Species Observed**

Fauna Classification	Number of Species Observed
Bird	84
Fish	10
Butterfly	12
Amphibian	2
Reptile	3

## 4.2. Potential Impacts and Mitigation

An important component of the EIA report is the identification of potential impacts that the project may have on the surrounding environmental. Project-environment interactions were ascertained based on the design of the San Fernando WWTP and collection system and the environmental baseline assessment of the project area. An environmental interaction is any element of a facility's activities, products, operations or services which can or will interact with the environment. These interactions





and their effects may be continuous in nature, occur periodically, or may be associated with specific events, such as emergencies. Some interactions may be beneficial, such as a reduction in odours, however, the primary objective of this EIA study is to identify and minimize the negative impacts. The project-environment interactions considered are identified in Table 6. Accidents and emergency situations were studied separately.

**Table 6 Project-Environment Interaction with Affected Environment**

Project-Environment Interaction	Affected Environment					
	Water	Air	Soil	Biological	Transportation	Other Social
Storage/staging and stockpiling of materials, and chemicals <sup>C,O</sup>	x	x	x		x	x
Obtain easements <sup>C</sup>						x
Use of labour <sup>C,O</sup>						x
Transportation to and from site (personnel, equipment, machinery) <sup>C,O</sup>		x			x	
Use of construction equipment and machinery <sup>C</sup>		x	x	x		x
Use of lighting <sup>C,O</sup>				x		x
Storage and disposal of construction debris and waste <sup>C</sup>	x				x	x
Use of chemicals, coatings and paint <sup>C,O</sup>		x				
Ground excavation, vegetation clearing, ground compaction, trenching, piling <sup>C</sup>	x	x	x	x	x	
Alteration of grade and drainage patterns <sup>C</sup>	x		x			
Construction of WWTP <sup>C</sup>	x	x	x			
Construction of Collection System Sewer <sup>C</sup>	x	x	x		x	
Water supply management <sup>O</sup>	x					
Effluent release to catchments <sup>C, O</sup>	x			x		x
WWTP Equipment operation <sup>O</sup>		x				
Sludge Management <sup>C,O</sup>		x	x		x	
Odour Management <sup>C,O</sup>		x				

Note: C = construction phase; O = operation phase

These project-environment interactions were evaluated and the impact to water, air, soil, biology, transport and social parameters was discussed. The impact of each variable on these environmental parameters was reviewed according to magnitude, scope, direction and degree of irreversibility. The mitigation measures assimilated in the design as well as those institutionalised outside of the design



were presented and the residual impact was discussed post-mitigation. A summary of the proposed project impacts before and after (pre and post) mitigation is displayed in (Table 7).

**Table 7 Summary of Impacts Pre-and Post Mitigation**

Classification of Potential Impact	Project Phase	Potential Impact	Unmitigated Magnitude of Impact	Post-Mitigation Residual Impact
Air Quality	Construction	Exhaust Emissions	Minor on site, negligible off site Negative	Minor on site, Negligible off site Negative
		Airborne dust and particles	Minor Negative	Minor on site, Negligible off-site Negative
		Odours	Minor to Moderate Negative	Negligible Negative
	Operation	Exhaust Emissions	Minor Positive	-
		Airborne dust and particles	Minor Negative	Negligible Negative
		Odours	Minor to Moderate Negative	Negligible Negative
Noise	Construction	Noise from vehicles, equipment, and construction	Minor to Moderate Negative	Minor to Moderate Negative
	Operation	Operational Noise	Moderate Negative	Negligible Negative
Water	Construction	Land Clearing and excavation along watercourses	Minor Negative	Negligible Negative
		Release of untreated wastewater from San Fernando WWTP	Major Negative	Negligible Negative
	Operation	Release of untreated wastewater from San Fernando WWTP	Major Negative	Negligible Negative
		Water Quality Improvement	Major Positive	-
		Potable Water Use	Minor Positive	-
Soil	Construction	Erosion	Moderate Negative	Negligible to Minor Negative
		Soil Compaction	Minor Negative	Negligible Negative
		Sludge Management	Minor Negative	Negligible Positive
	Operation	Erosion from Outfall	Moderate Negative	Negligible Negative



**Table 7 Summary of Impacts Pre-and Post Mitigation (continued)**

Classification of Potential Impact	Project Phase	Potential Impact	Unmitigated Magnitude of Impact	Post-Mitigation Residual Impact
Flora	Construction	Species Loss	Minor to Major Negative	Negligible to Minor Negative
		Dust Deposition	Minor to Negligible Negative	Negligible Negative
	Operation	Landscaping	Negligible	Neutral
Fauna	Construction	Habitat Loss	Moderate Negative	Negligible to Minor Negative
		Habitat Modification	Moderate Negative	Negligible to Minor Negative
	Operation	Habitat Modifications	Moderate Positive	-
		Aquatic Fauna Species Growth	Major Positive	-
		Lighting	Minor Negative	Negligible Negative
Transportation	Construction	Traffic increase to site	Minor Negative	Minor Negative
		Traffic disruptions from collection system road right of way construction	Major Negative	Minor to Moderate Negative
	Operation	Traffic increase to site	Negligible to Minor Negative	Negligible Negative
Social	Construction	Labour Requirement	Minor Positive	-
		Land Acquisition	Minor Negative to Positive (site dependant)	Negligible Negative to Positive
		Health and Injuries	Minor to Major Negative	Minor to Negligible Negative
		Blocked properties and visual intrusion from construction material	Minor Negative	Negligible Negative
		Use of lighting	Minor Negative	Negligible Negative

**Table 7 Summary of Impacts Pre-and Post Mitigation (continued)**

Classification of Potential Impact	Project Phase	Potential Impact	Unmitigated Magnitude of Impact	Post-Mitigation Residual Impact
Social	Operation	Labour Requirement	Minor Negative	Negligible Negative
		Economics – Change to Wastewater Fees	Major for Country Negative	Major Neutral to Negative
		Use of lighting	Minor	Negligible Negative
		Water Quality Improvement	Major Positive	-
Cumulative	Construction	Other construction projects within San Fernando Area	To be studied on a case-by-case basis throughout construction	To be studied on a case-by-case basis throughout construction
		Utility upgrade or installation at same time as collection system work	Minor to Major Positive	-
	Operation	Water Quality Improvement	Major Positive	-

A major positive impact from the San Fernando Wastewater Project is the improvement in surface water quality in the region, as a result of the untreated wastewater being properly collected and treated at the new WWTP. Cleaning up the waterways in the catchment area will result in a habitat improvement for aquatic species, improved public health and decrease in waterborne illnesses for humans, and overall improvement in the quality of life.

The most significant negative impact is disruption of traffic flow during construction. Traffic disruption has potential to affect over 10% of the San Fernando and environs population and will impact localized areas throughout the construction process. A significant portion of the construction will be within road right-of-ways. Mitigation of traffic impacts will be accomplished by utilizing trenchless technology in high traffic roadways, and a comprehensive traffic management plan that includes provisions for proper detours and signage, provision of access to all businesses and properties, restrictions on construction hours, and limits on the amount of construction that can occur at any one location. Once these mitigation measures are utilized in the construction, the unmitigated major negative impact becomes a mitigated minor to moderate negative impact.

The cumulative impacts of simultaneous activities were evaluated and include:

- Existing and proposed construction projects
- Utility installation and upgrade



The cumulative impact of these activities can be moderate on a regional scale. However, effective liaison between the respective agencies and stakeholders conducted during the design phase of the San Fernando Wastewater Project has identified this project to all agencies and stakeholders, and with proper planning and communication, would mitigate this impact to a minor scale.

The potential for accidents and plant malfunctions was examined as part of the EIA. The probability and impact of the following events were categorised;

- Spills
- Process Upset
- Natural Hazards
- Power Failures
- Fires
- Injury/Death

Post-mitigation, the residual impacts ranged from negligible to minor in magnitude. The key principle governing the reduction of impacts and encompassing mitigation measures was discovered to be adherence to national rules and regulations and contract specifications and guidelines.

### 4.3. Environmental Monitoring and Management

The granting of a CEC could be accompanied by a requirement for an environmental monitoring and management plan. The potential impacts were identified and appropriate mitigation measures were incorporated into the design, however, there are some residual impacts that would require participation of external institutions for prevention and minimisation to be achievable.

Consequently, an environmental monitoring and management plan was formulated and specified for inclusion in the tender documents as a contract requirement for the Contractor to implement. The monitoring plan covers both environmental and social issues including; the terrestrial and aquatic environment, air, land/soil, odour, traffic and public health and safety. Environmental management during construction was incorporated in the form of a specification that deals with proper waste storage and disposal, drainage and siltation control, and protection of the natural and man-made environment. The procedure by which the Contractor and all other personnel will comply with the relevant regulations and the stipulations of the San Fernando Wastewater Project is outlined in the environmental monitoring and management plan. The enforcement of the plan will chiefly be attained via direct and constant supervision by WASA and the assigned resident engineer and site supervision team who will ensure that all specifications of the contract are adhered to and protection of the environment and worker health and safety is achieved.

## 5. Summary

The proposed San Fernando Wastewater Project will have a major positive impact to the rivers and surrounding environment in San Fernando and Environs through the proper collection, treatment and disposal of wastewater that is presently discharging into rivers and watercourses. The project will also decrease waterborne diseases, safeguard public health and improve the overall quality of life of the residents.



There are no significant long term negative impacts to the social or biophysical environment, only short term impacts during construction. Most of the impacts are confined to WWTP site and collection system right of ways. The impact of traffic disruption during construction has been reduced with the use of trenchless technology in high-traffic areas, and implementation of a traffic management plan, to be enforced by the Contractor, WASA and the Ministry of Works and Transport. Construction of the proposed San Fernando Wastewater Project is a vital component to WASA's overall master plan of improving the level of wastewater services to all residents of Trinidad and Tobago.



## Acronyms

Acronym	Meaning
24/7	24 hours a day, 7 days a week
µm	Micrometre
ADWF	Average Dry Weather Flow
APR	Air Pollution Rules
AS	Activated Sludge
ASTM	American Society for Testing and Materials
AWWA	American Water Works Association
BFP	Belt Filter Press
BOD	Biological Oxygen Demand
Bq	Becquerel
CBOD	Carbonaceous Biological Oxygen Demand
CCTV	Closed Circuit Television
CEC	Certificate of Environmental Clearance
CFU	Coliform Forming Units
CITES	Convention on International Trade in Endangered Species of Wild Fauna and Flora
Co	Company
CO <sub>2</sub>	Carbon Dioxide
COD	Chemical Oxygen Demand
CSO	Central Statistical Office
d	Day
DAF	Dissolved Air Flotation
dB	Decibels
dBA	Decibels (A-weighted)
DF	Denitrifying Filter
DO	Dissolved Oxygen
E	East
ED	Enumeration District
EIA	Environmental Impact Assessment
EIS	Environmental Impact Statement
EMA	Environmental Management Authority
USEPA	United States Environmental Protection Agency
ESA	Environmentally Sensitive Areas
ESS	Environmentally Sensitive Species
eTeck	Evolving Technologies and Enterprise Development Company of Trinidad and Tobago
F	Filtration
FLOW	Columbus Communications Trinidad Limited
FM	Geological formation
GHG	Greenhouse Gases



Acronym	Meaning
GORTT	Government of the Republic of Trinidad and Tobago
GP	Grinder Pump
GPS	Global Positioning System
H <sub>2</sub> O	Water
HDC	Housing Development Corporation of Trinidad and Tobago
HDD	Horizontal Directional Drilling
HMI	Human-Machine Interface
hr	Hour
HRT	Hydraulic Retention Time
HSE	Health, Safety and the Environment
I&C	Instrumentation and Control
I&I	Infiltration and Inflow
Inc.	Incorporated
ITCZ	Inter Tropical Convergence Zone
IUCN	International Union for Conservation of Nature
kg	Kilograms
km	Kilometres
km <sup>2</sup>	Square kilometres
kW	Kilowatt
L	Litres
L <sub>eq</sub>	Equivalent sound pressure level
L <sub>peak</sub>	Peak sound pressure level
Lpcd	Litres per capita per day
LS	Lift Station
LSA	Land Settlement Agency
Ltd	Limited
m	Metres
m <sup>2</sup>	Square metres
m <sup>3</sup>	Cubic metres
M	Million
masl	Metres above sea level
MBBR	Moving Bed Biofilm Reactor
MBR	Membrane Bioreactor
mg	Milligrams
ml	Millilitres
mm	Millimetres
ML	Mega litres
MLSS	Mixed Liquor Suspended Solids
MODSEC	San Fernando Central Secondary School
MOWT	Ministry of Works and Transport
MPN	Most Probable Number
MSDS	Material Safety Data Sheets





Acronym	Meaning
mW	Milliwatt
N	North
NEP	National Environmental Policy
NGC	National Gas Company of Trinidad and Tobago
NH <sub>3</sub>	Ammonia
NPCR	Noise Pollution Control Rules
O&M	Operation and Maintenance
O <sub>2</sub>	Oxygen
ODPM	Office of Disaster Preparedness and Management
OFR	Over Flow Rate
OSH	Occupational Safety and Health
OTR	Oxygen Transfer Rate
Pa	Pascal
pe	Population Equivalent
Petrotrin	Petroleum Company of Trinidad and Tobago
PDWF	Peak Dry Weather Flow
PLC	Programmable Logic Controllers
PM <sub>2.5</sub>	Particulate Matter (weighing $\leq 2.5 \mu\text{m}$ )
PM <sub>10</sub>	Particulate Matter (weighing $\leq 10 \mu\text{m}$ )
PWWF	Peak Wet Weather Flow
RAS	Return Activated Sludge
ROW	Right-of-way
s	Second/s
S	South
SBR	Sequencing Batch Reactors
SFWWTP	San Fernando Wastewater Treatment Plant
SGD	Small Gravity Diameter
SHE	Safety, Health and the Environment
SLR	Solids Loading Rate
SND	Simultaneous-Nitrification-Denitrification
SOTR	Standard Oxygen Transfer Rate
SOUR	Specific Oxygen Uptake Rate
SPAW	Specially Protected Areas and Wildlife
SPL	Sound Pressure Level
SRT	Solids Retention Time
STEP	Septic Tank Effluent Pump
SWD	Side Water Depth
SWMCOL	Solid Waste Management Company Limited
T&T	Trinidad and Tobago
T&TEC	Trinidad and Tobago Electricity Commission
TCPD	Town and Country Planning Division
TDH	Total Dynamic Head



Acronym	Meaning
TF	Trickling Filter
TGR	Trinidad Government Railway
TKN	Total Kjeldahl Nitrogen
TN	Total Nitrogen
TP	Total Phosphorus
TOR	Terms of Reference
TSP	Total Suspended Particulates
TSS	Total Suspended Solids
TSTT	Telecommunication Service of Trinidad and Tobago
UDECOTT	Urban Development Corporation of Trinidad and Tobago Limited
UN	United Nations
U.S.	United States
UV	Ultraviolet
U.W.I.	University of the West Indies
VSS	Volatile Suspended Solids
W	West
WAS	Waste Activated Sludge
WASA	The Water and Sewerage Authority
WPR	Water Pollution Rules
WWTP	Wastewater Treatment Plant



## Glossary

Term	Definition
Activated Sludge	Biomass produced in raw or settled wastewater by the growth of microorganisms in aeration tanks in the presence of dissolved oxygen. Microorganisms become “activated” in a selected environment and breakdown the incoming wastewater.
Aerobic digester	Treatment of waste activated sludge in an aerated tank where organics are oxidised to carbon dioxide, water and ammonia and air is supplied from blowers.
Alluvial	Loose, unconsolidated sediment.
Archaeology	The study of remnants of a human society through recovery of materials left behind.
Avifauna	The bird population of a region or area.
Belt Filter Press (BFP)	Continuous-feed sludge dewatering devices that involve the application of chemical conditioning, gravity drainage and mechanically applied pressure between porous belts to dewater sludge.
Benthopelagic	Living on or occurring at bottom or at mid-level depth in a body of water
Bioreactor	Tanks in which biochemical reactions take place. Organics in wastewater are converted to respiratory products (water and oxygen) and cellular material. Nutrients (Ammonia, nitrates, nitrites, Phosphorus etc.) can also be selected and reduced to defined limits.
Biosolids	By-product of wastewater treatment, also called treated sludge which comprises of 1 to 10% solids.
Blower	Mechanical device that supplies air.
Census	The procedure by which information about a population is acquired on a national level, in Trinidad and Tobago this is done every ten years.
Clarifier	A settling tank used to separate solids from liquids.
Collection System	The network of sewer pipes and lift stations which convey wastewater collected from properties to the wastewater treatment plant.
Regional/City Corporation	Corporate body administering the operations of the city or community. This includes; drainage, roads and public places.
Demographics	Characteristics of a population which explains its social composition, chiefly age, sex, religion and ethnicity.
Denitrification	A biological process employed to convert the nitrate-nitrogen in effluent from the activated sludge into elemental nitrogen gas.
Dissolved Air Flotation (DAF)	Process of removing solids from liquid by releasing fine air bubbles into the wastewater, the solid particles adhere to the bubbles, and float to the top where it is then removed.
Earthworks	The man-made alternations to the natural topography of a site, specifically grading and backfilling.
Effluent	Treated wastewater released into the natural environment by wastewater treatment plants.
Enumeration District	A defined geographical area comprising approximately 150 to 200



Term	Definition
	households.
Fault	Planar rock fracture along which the rocks on either side have moved relative to the other.
Filtration	The process by which suspended solids are removed.
Geological Formation (FM)	A rock unit with similar characteristics, particularly type of sediment or fossils.
Grit	Heavier inorganic solids contained in wastewater.
Hydrometric Region	Physical zone exposed with similar hydrological components, typically rainfall and groundwater.
Inter Tropical Convergence Zone (ITCZ)	Equatorial zone of low pressure where trade winds from the northern and southern hemisphere converge and uplifted.
Lift Station	Facility at which wastewater is pumped from one area to a next. It is generally needed when gravity sewer pipes become too deep to construct due to gravitational and hydraulic controls.
Liquefaction	Reduction of strength and stiffness of soil as a result of earth movements.
Marl	Lime-rich mud.
Mitigation	The moderation, prevention or reduction of an impact by addressing the issue before the consequence.
Mixed Liquor	Mixture of raw wastewater and microorganisms in a biological mass.
Mudflat	Coastal wetlands comprising of mud, sand or gravel formed by deposition of sediments from rivers or/and tides in sheltered areas.
Nitrification	The biological conversion of ammonia to nitrate-nitrogen.
Particulate Matter	Mixture of small particles and liquid droplets comprising of acids, organic chemicals, soils and dust.
Petit Careme	Weather phenomenon experienced during the wet season specifically in September and October categorised by higher temperatures.
Polymers	A coagulant added to wastewater to help separate out solids from liquids.
Primary Treatment	Initial treatment where the heavier and more easily settleable solids in raw wastewater are removed. These include large solids that settle quickly such as sand, gravel and floating materials.
Return Activated Sludge (RAS)	Sludge collected in the secondary clarifiers and returned to the bioreactor to ensure sufficient mixed liquor concentration of the activated sludge is maintained to obtain required treatment.
Riparian	Vegetation adjacent to or connected with a water course
Runoff	Water that flows off from a man-made surface or structure.
Screenings	Organic and inorganic materials large enough to be removed on bar racks.
Scrub	Short, dense vegetation made of shrubs, ferns and young trees.
Scum	Floatable materials skimmed from the surface of primary and secondary settling tanks. May contain grease, detergents, soaps, food wastes, hair, paper.
Secondary Clarifier	A settling tank that separates mixed liquor from a bioreactor into RAS and clarified effluent.



Term	Definition
Secondary Treatment	Wastewater treatment where biological content of wastewater is degraded.
Sedge	Grass-like or low level trees.
Sedimentation	The process by which sediments are deposited or settled in a rock unit.
Seismic	Relating to or cause by earthquake activity.
Septage	Sewage at individual on-site sewage systems, mainly septic tanks and cesspits.
Sewage	Domestic wastewater primarily from human wastes (toilet, sink, shower, etc.).
Shale	Fine-grained mud which is characterised by parallel thin layers.
Socio-Economic	The combination of social and economic factors such as; employment and education.
Specification	A precise requirement of a contract to be fulfilled via the delivery of a material, product or service.
Stakeholder	A person or organization that has a direct or indirect investment in the project because the stakeholder will be affected by any decisions or outcomes of the project.
Stratigraphy	Layering or strata of a rock unit
Syncline	A fold in a rock unit that dips downward or is “U-shaped”.
Tertiary Treatment	Following secondary treatment, additional level of treatment to meet the stipulated criteria, including nutrient removal and disinfection.
Tsunami	A series of ocean waves.
Ultraviolet (UV) Disinfection	The reduction of microorganisms in water by exposing the bacteria to UV radiation which damages the genetic structure of the organism disabling their ability to reproduce.
Waste Activated Sludge (WAS)	Excess sludge from the RAS which is used to maintain the food to microorganism ratio. WAS is treated.
Wastewater	All water that is processed including domestic and industrial wastewater.
Wastewater Catchment	Physical area defined by topographic, drainage and wastewater collection system in which all the wastewater is treated at one facility.
Watershed	An area of land in which water flows toward the same water course or river.
Wet Well	Chamber or tank in which wastewater is collected before it is treated or pumped.



# Table of Contents

Statement of Qualifications and Limitations

Executive Summary

Acronyms

Glossary

Page

- 1. Introduction..... 1-1**
  - 1.1 Overview..... 1-1
  - 1.2 Project Background ..... 1-1
  - 1.3 San Fernando Wastewater Treatment Plant and Collection System ..... 1-2
  - 1.4 Scope of the EIA..... 1-4
  - 1.5 Report Structure..... 1-4
  - 1.6 List of Report Preparers and EIA Project Team..... 1-5
- 2. Legislative, Regulatory, and Policy Framework..... 2-1**
  - 2.1 Introduction..... 2-1
  - 2.2 Environmental Management Act..... 2-1
    - 2.2.1 Environmental Management Authority ..... 2-1
    - 2.2.2 Certificate of Environmental Clearance Rules ..... 2-2
    - 2.2.3 Water Pollution Rules..... 2-3
    - 2.2.4 Noise Pollution Control Rules ..... 2-6
    - 2.2.5 Draft Air Pollution Rules..... 2-8
    - 2.2.6 Environmentally Sensitive Areas Rules ..... 2-8
    - 2.2.7 Environmentally Sensitive Species Rules ..... 2-9
    - 2.2.8 Draft Waste Management Rules ..... 2-10
  - 2.3 Water and Sewerage Act ..... 2-10
    - 2.3.1 WASA – Water and Wastewater Design Guidelines ..... 2-12
  - 2.4 Forest Act..... 2-14
  - 2.5 Fisheries Act ..... 2-15
  - 2.6 Plant Protection Act..... 2-15
  - 2.7 Conservation of Wildlife Act..... 2-16
  - 2.8 Occupational Safety and Health Act..... 2-16
  - 2.9 Trinidad and Tobago Bureau of Standards..... 2-17
    - 2.9.1 Specification for the Liquid Effluent from Domestic Wastewater Treatment Plants into the Environment ..... 2-18
    - 2.9.2 Specification for the Effluent from Industrial Processes Discharged into the Environment..... 2-18
  - 2.10 National Policies..... 2-19
    - 2.10.1 National Environmental Policy..... 2-20
    - 2.10.2 National Wetlands Policy ..... 2-21
    - 2.10.3 Draft National Protected Areas Policy ..... 2-22
    - 2.10.4 Draft National Forest Policy ..... 2-23
  - 2.11 Multilateral Agreements/Conventions..... 2-24
  - 2.12 Approval Agencies ..... 2-25
    - 2.12.1 The Environmental Commission ..... 2-26
    - 2.12.2 Town and Country Planning Division ..... 2-26



2.12.3 Municipal Corporations ..... 2-27  
 2.12.4 Ministry of Works and Transport ..... 2-28

**3. Project Description ..... 3-1**

3.1 Objective ..... 3-1  
 3.2 Project Background ..... 3-1  
 3.3 Project Boundaries ..... 3-2  
 3.4 Land Use and Population ..... 3-4  
 3.5 Existing Sewered Areas ..... 3-6  
 3.5.1 San Fernando City Sewerage System ..... 3-9  
 3.5.2 Palmiste Development Sewerage System ..... 3-10  
 3.5.3 Union Hall Development Sewerage System ..... 3-10  
 3.5.4 Gulf View Development Sewerage System ..... 3-10  
 3.6 Present Wastewater Volume and Strength ..... 3-10  
 3.7 Design Effluent Flows and Criteria ..... 3-14  
 3.7.1 Design Flows ..... 3-14  
 3.7.2 Design Effluent Criteria ..... 3-15  
 3.8 Overall Scope of Works ..... 3-17  
 3.9 Wastewater Treatment Plant Scope of Works ..... 3-17  
 3.9.1 Influent Pump Station ..... 3-23  
 3.9.2 Septage Receiving ..... 3-24  
 3.9.3 Fine Screens ..... 3-25  
 3.9.4 Grit Removal ..... 3-26  
 3.9.5 Flow Measurement and Wet Weather Storage ..... 3-27  
 3.9.6 Storm Water Storage ..... 3-27  
 3.9.7 Bioreactors ..... 3-28  
 3.9.8 Secondary Clarifiers ..... 3-29  
 3.9.9 Filtration ..... 3-29  
 3.9.10 UV Disinfection ..... 3-30  
 3.9.11 Secondary Sludge Pumping ..... 3-31  
 3.9.12 Sludge Thickening ..... 3-32  
 3.9.13 Aerobic Digestion ..... 3-33  
 3.9.14 Sludge Dewatering and Loadout ..... 3-33  
 3.9.15 Wastewater Reuse Option ..... 3-35  
 3.9.16 Chlorination Facility ..... 3-35  
 3.9.17 Polymer Addition ..... 3-35  
 3.9.18 Utility Requirements ..... 3-35  
 3.9.19 Design Summary ..... 3-36  
 3.10 Collection System Scope of Works ..... 3-45  
 3.10.1 Sewer Piping Network ..... 3-45  
 3.11 Wastewater Lift Stations ..... 3-67  
 3.12 Pre-Construction Activities ..... 3-67  
 3.12.1 Land Acquisition ..... 3-67  
 3.13 Construction Phase ..... 3-68  
 3.13.1 Project Phasing ..... 3-68  
 3.13.2 Sewer Location and Alignment ..... 3-72  
 3.13.3 Crossing Clearance to Sewers ..... 3-72  
 3.13.4 Pipe Bedding, Backfill and Reinstatement ..... 3-72  
 3.13.5 Sewer Installation Techniques ..... 3-73



3.13.6	Site Grading and Drainage.....	3-75
3.13.7	Erosion Control.....	3-75
3.13.8	Traffic to Site.....	3-75
3.14	Operation of San Fernando Wastewater System.....	3-76
3.14.1	Labour Requirements.....	3-76
3.14.2	Treatment Plant Process Control.....	3-76
3.14.3	Instrumentation and Control.....	3-77
3.14.4	Waste Management.....	3-77
3.15	Demolition and Decommissioning of Existing Facilities.....	3-78
3.15.1	Demolition Process.....	3-79
3.15.2	Demolition Operations.....	3-79
3.15.3	Removal Operations.....	3-79
3.15.4	Abandonment Operations.....	3-80
3.15.5	Disposal.....	3-80
3.16	Demolition and Decommissioning of New San Fernando Wastewater Project.....	3-80
<b>4.</b>	<b>Analysis of Alternatives.....</b>	<b>4-1</b>
4.1	Wastewater Treatment Plant Location.....	4-1
4.2	Type of Collection System.....	4-1
4.2.1	Low Pressure System.....	4-2
4.2.2	Vacuum System.....	4-2
4.2.3	Small Diameter Gravity (SDG) System.....	4-3
4.2.4	Centralized Conventional Gravity Sewer System.....	4-3
4.3	Selection of Wastewater Treatment System.....	4-4
4.3.1	Liquids Treatment Process Options.....	4-4
4.3.2	Comparison of the Liquid Stream Options.....	4-14
4.3.3	Solids Treatment Process Options.....	4-17
4.3.4	Comparison of the Solids Stream Options.....	4-23
4.4	No Action Alternative.....	4-24
<b>5.</b>	<b>Biophysical Environment Setting.....</b>	<b>5-1</b>
5.1	Introduction.....	5-1
5.2	Climate.....	5-1
5.2.1	Wind Speed and Wind Direction.....	5-2
5.2.2	Temperature.....	5-3
5.2.3	Humidity.....	5-4
5.2.4	Precipitation.....	5-5
5.3	Natural Hazards.....	5-7
5.3.1	Floods.....	5-7
5.3.2	Bush Fires.....	5-8
5.3.3	Hurricanes.....	5-8
5.3.4	Earthquakes.....	5-10
5.3.5	Tsunami Hazards.....	5-12
5.4	Soils.....	5-13
5.4.1	San Fernando WWTP.....	5-13
5.4.2	San Fernando Collection System.....	5-14
5.5	Geology.....	5-18
5.6	Topography.....	5-21
5.7	Drainage.....	5-21





5.8	Water Quality.....	5-24
5.8.1	Faecal Coliforms.....	5-36
5.8.2	BOD <sub>5</sub> and COD.....	5-37
5.8.3	Dissolved Oxygen.....	5-37
5.8.4	Total Suspended Solids.....	5-37
5.8.5	Ammonia.....	5-37
5.8.6	Total Phosphorus.....	5-38
5.8.7	Metals.....	5-38
5.9	Biological Environment.....	5-38
5.9.1	Land Use of Project Area.....	5-38
5.10	Flora.....	5-41
5.11	Fauna.....	5-42
5.12	Noise Quality.....	5-78
5.13	Ambient Air Quality.....	5-82
<b>6.</b>	<b>Social Environmental Conditions.....</b>	<b>6-1</b>
6.1	Introduction.....	6-1
6.2	Study Area.....	6-1
6.3	Methodology.....	6-2
6.4	Historical Development of Study Area.....	6-3
6.5	Land Use.....	6-4
6.6	Archaeology Sites.....	6-7
6.7	Employment.....	6-9
6.8	Recreational Activities.....	6-12
6.9	Public Buildings and Institutions.....	6-12
6.9.1	Schools.....	6-12
6.9.2	Community Centres.....	6-12
6.9.3	Courts.....	6-13
6.9.4	Libraries.....	6-13
6.10	Population Demographics.....	6-15
6.10.1	General.....	6-15
6.10.2	Age.....	6-16
6.10.3	Religion.....	6-17
6.10.4	Ethnicity.....	6-18
6.11	Quality of Life.....	6-20
6.11.1	Education.....	6-20
6.11.2	Housing.....	6-22
6.11.3	Water Supply.....	6-22
6.11.4	Sewer Collection.....	6-23
6.11.5	Electricity Supply.....	6-25
6.11.6	Telecommunications.....	6-27
6.11.7	Summary.....	6-28
6.12	Social Services.....	6-28
6.12.1	Health.....	6-29
6.12.2	Transport.....	6-29
6.12.3	Education.....	6-30
6.12.4	Police.....	6-31
6.12.5	Fire.....	6-31
6.13	Social Survey.....	6-31



- 6.13.1 Methodology..... 6-31
- 6.13.2 Socio-Economics ..... 6-32
- 6.13.3 Project Awareness ..... 6-32
- 6.13.4 Perceived Impacts and Concerns ..... 6-33
- 6.14 Road Traffic Survey ..... 6-35
- 7. Key Stakeholder and Public Consultations..... 7-1**
  - 7.1 Requirements of CEC TOR ..... 7-1
  - 7.2 Introductory Meetings with Key Stakeholders ..... 7-2
  - 7.3 Key Stakeholder Meeting ..... 7-3
  - 7.4 Public Consultations ..... 7-4
    - 7.4.1 Public Consultation # 1 ..... 7-4
    - 7.4.2 Public Consultation # 2..... 7-6
  - 7.5 Conclusion ..... 7-8
- 8. Impact Analysis and Mitigation Measures..... 8-1**
  - 8.1 Methodology..... 8-1
    - 8.1.1 Impacts Assessment..... 8-1
    - 8.1.2 Mitigation Measures ..... 8-3
  - 8.2 Project- Environment Interactions ..... 8-3
  - 8.3 Air Quality Impacts and Mitigation..... 8-5
    - 8.3.1 Construction Phase ..... 8-5
    - 8.3.2 Operation Phase ..... 8-7
  - 8.4 Noise Impacts and Mitigation..... 8-9
    - 8.4.1 Construction Phase ..... 8-9
    - 8.4.2 Operational Phase ..... 8-10
  - 8.5 Water Impacts and Mitigation ..... 8-10
    - 8.5.1 Construction Phase ..... 8-10
    - 8.5.2 Operation Phase ..... 8-12
  - 8.6 Soil and Land Impacts and Mitigation..... 8-13
    - 8.6.1 Construction Phase ..... 8-13
    - 8.6.2 Operation Phase Erosion..... 8-14
  - 8.7 Biological Impacts and Mitigation ..... 8-14
    - 8.7.1 Construction Phase: Flora..... 8-14
    - 8.7.2 Construction Phase: Fauna ..... 8-15
    - 8.7.3 Operation Phase: Flora ..... 8-16
    - 8.7.4 Operation Phase: Fauna ..... 8-16
  - 8.8 Transportation Impacts and Mitigation ..... 8-17
    - 8.8.1 Construction Phase ..... 8-17
    - 8.8.2 Operation Phase ..... 8-22
  - 8.9 Social Impacts and Mitigation ..... 8-22
    - 8.9.1 Construction..... 8-22
    - 8.9.2 Operation ..... 8-24
  - 8.10 Cumulative Impacts and Mitigation ..... 8-26
    - 8.10.1 Existing and Proposed Construction Projects..... 8-26
    - 8.10.2 Utility Installation or Upgrade..... 8-27
    - 8.10.3 Untreated Wastewater Discharges ..... 8-27
  - 8.11 Summary of Impacts and Mitigation ..... 8-27
  - 8.12 Accidents and Malfunctions ..... 8-33



8.12.1	Spills .....	8-33
8.12.2	Process Disruption .....	8-35
8.12.3	Natural Hazards .....	8-36
8.12.4	Power Failure .....	8-36
8.12.5	Fire .....	8-37
8.12.6	Injury/Death .....	8-37
<b>9.</b>	<b>Environmental Monitoring and Management Plan .....</b>	<b>9-1</b>
9.1	Environmental Monitoring .....	9-1
9.2	Social Monitoring .....	9-1
9.3	Management .....	9-2
9.3.1	Protection of Environment Specification .....	9-2
9.3.2	Traffic Control Specification .....	9-3
9.3.3	Waste Management Plan .....	9-4
9.3.4	Mitigation Action Plan .....	9-5
9.3.5	Emergency Response Plan .....	9-5
9.4	Compliance .....	9-5
<b>10.</b>	<b>Bibliography .....</b>	<b>10-1</b>

## List of Figures

Figure 1	San Fernando Wastewater Catchment Area .....	E-2
Figure 2	Existing Sewered Areas (shaded) and WWTPs in San Fernando Project Area .....	E-3
Figure 3	Existing and Proposed WWTP Site .....	E-5
Figure 4	WWTP Liquid Stream Flow Schematic .....	E-7
Figure 5	WWTP Solid Stream Flow Schematic .....	E-8
Figure 6	Subcatchments of the San Fernando Wastewater Project .....	E-9
Figure 7	Proposed San Fernando Wastewater Collection System .....	E-11
Figure 8	Phase I Construction Contract: WWTP and Collection System .....	E-13
Figure 1-1	San Fernando Wastewater Project Area .....	1-3
Figure 3-1	Project Boundaries, Roads and Rivers .....	3-3
Figure 3-2	Map of San Fernando and Environs Showing Land Use (White, 2009) .....	3-5
Figure 3-3	Existing Lift Stations and WWTPs, with current sewered areas displayed .....	3-8
Figure 3-4	Section of Trunk Sewer Along the Sea Wall Showing Possible Points of Inflow at Pipe Joints .....	3-9
Figure 3-5	Section of Trunk Sewer along Vistabella River Showing Open Joint .....	3-9
Figure 3-6	Location of Existing San Fernando WWTP .....	3-17
Figure 3-7	WWTP Liquids Flow .....	3-19
Figure 3-8	WWTP Solids Flow Schematic .....	3-20
Figure 3-9	WWTP Process Flow Diagram .....	3-21
Figure 3-10	WWTP Site Plan .....	3-22
Figure 3-11	Water Balance Flow Schematic for San Fernando WWTP .....	3-23
Figure 3-12	Dry Pit Submersible Pumps (Chicago Pump) .....	3-24



Figure 3-13 Package Septage Receiving Unit (Courtesy of JWC Environmental) ..... 3-25

Figure 3-14 Band – Type Fine Screen (Courtesy of JWC Environmental)..... 3-26

Figure 3-15 Screenings Compactor (Courtesy of Huber Technology)..... 3-26

Figure 3-16 Recently Refurbished Primary Clarifiers at San Fernando WWTP..... 3-28

Figure 3-17 Fine Bubble Aeration Bioreactor ..... 3-29

Figure 3-18 Cloth Media Filter (Courtesy of Aqua-Aerobic Systems) ..... 3-30

Figure 3-19 Cloth Media Filtration Plant (Courtesy of Aqua-Aerobic Systems)..... 3-30

Figure 3-20 WAS, RAS, and Scum Decanter Schematic ..... 3-32

Figure 3-21 Stainless Steel DAF Tank ..... 3-33

Figure 3-22 Three Belt Filter Press (courtesy of Andritz)..... 3-34

Figure 3-23 San Fernando Proposed New Collection System..... 3-47

Figure 3-24 San Fernando Collection System Subcatchments..... 3-48

Figure 3-25 Marabella Subcatchment New Sewer Layout ..... 3-50

Figure 3-26 Tarouba-Cocoyea Subcatchment New Sewer Layout ..... 3-51

Figure 3-27 Cocoyea South Subcatchment New Sewer Layout..... 3-52

Figure 3-28 Pleasantville-Corinth Subcatchment New Sewer Layout ..... 3-53

Figure 3-29 Vistabella-Gulf Subcatchment New Sewer Layout ..... 3-54

Figure 3-30 San Fernando South Subcatchment New Sewer Layout..... 3-55

Figure 3-31 Ste. Madeline Subcatchment New Sewer Layout..... 3-56

Figure 3-32 Bel Air-Gulf View Subcatchment New Sewer Layout..... 3-57

Figure 3-33 Green Acres Subcatchment New Sewer Layout ..... 3-58

Figure 3-34 Duncan Village Subcatchment New Sewer Layout..... 3-59

Figure 3-35 Union Hall Subcatchment New Sewer Layout ..... 3-60

Figure 3-36 Retrench Golconda Subcatchment New Sewer Layout ..... 3-61

Figure 3-37 La Romain North Subcatchment New Sewer Layout..... 3-62

Figure 3-38 La Romain Central Subcatchment New Sewer Layout ..... 3-63

Figure 3-39 La Romain South Subcatchment New Sewer Layout..... 3-64

Figure 3-40 Palmiste South Subcatchment New Sewer Layout..... 3-65

Figure 3-41 Picton Subcatchment New Sewer Layout..... 3-66

Figure 3-42 Construction Phasing, Phase I..... 3-70

Figure 3-43 Trunk Sewer and Shaft Locations..... 3-74

Figure 4-1 Flow Schematic of Option L1 ..... 4-5

Figure 4-2 Cloth Media Filter (Courtesy of Aqua-Aerobic Systems) ..... 4-6

Figure 4-3 Conceptual Site Layout of Option L1 ..... 4-6

Figure 4-4 Flow Schematic of Option L2..... 4-8

Figure 4-5 Conceptual Site Layout of Option L2..... 4-8

Figure 4-6 Flow Schematic of Option L3..... 4-10

Figure 4-7 Conceptual Site Layout of Option L3..... 4-10

Figure 4-8 Flow Schematic of Option L4..... 4-11

Figure 4-9 Conceptual Site Layout of Option L4..... 4-12

Figure 4-10 Flow Schematic of Option L5..... 4-13

Figure 4-11 Conceptual Site Layout of Option L5..... 4-13

Figure 4-12 Schematic of Option S1 ..... 4-18

Figure 4-13 Schematic of Option S2 ..... 4-19

Figure 4-14 Schematic of Option S3 ..... 4-20



Figure 4-15 Schematic of Option S4 ..... 4-21

Figure 4-16 Schematic of Option S5 ..... 4-22

Figure 5-1 Mean Monthly Wind Speeds (Weather Underground Inc.)..... 5-3

Figure 5-2 Mean Monthly Temperatures (Weather Underground Inc.) ..... 5-4

Figure 5-3 Mean Monthly Humidity (Weather Underground Inc.)..... 5-5

Figure 5-4 Mean Monthly Precipitation (Meteorological Services Division)..... 5-6

Figure 5-5 Isohyetal Map of Trinidad (Genivar, 2009)..... 5-7

Figure 5-6 Hurricane Tracks for Trinidad during the period 1851 to 2008 (Storm CARIB Caribbean Hurricane Network) ..... 5-9

Figure 5-7 Recent Seismic Activity in Trinidad on 21 April 2010 ..... 5-10

Figure 5-8 Earthquake Epicenters with Magnitudes Greater Than 5 from 1900 to 2005 ..... 5-11

Figure 5-9 Seismic Hazard Map of Trinidad..... 5-12

Figure 5-10 Soils Map of Trinidad, 1971 (Lands and Surveys Division) ..... 5-15

Figure 5-11 Sites of Soil Investigation within San Fernando Collection System ..... 5-16

Figure 5-12 Physiographic Regions of Trinidad (Donovan, 1994) ..... 5-19

Figure 5-13 Geological Map of Project Area (Saunders, 1997)..... 5-20

Figure 5-14 Drainage Features within the San Fernando Wastewater Catchment..... 5-22

Figure 5-15 Hydrometric Areas and Watersheds of Trinidad (Genivar, 2009)..... 5-23

Figure 5-16 Sampling Locations for Water Quality Testing ..... 5-26

Figure 5-17 Guaracara River Upstream Sampling Location ..... 5-32

Figure 5-18 Guaracara River Downstream Sampling Location ..... 5-32

Figure 5-19 Marabella River Upstream Sampling Location ..... 5-33

Figure 5-20 Marabella River Gulf Sampling Location..... 5-33

Figure 5-21 Vistabella River Upstream Sampling Location ..... 5-34

Figure 5-22 Vistabella River Downstream Sample Location..... 5-34

Figure 5-23 Ciperio River Upstream Sampling Location..... 5-35

Figure 5-24 Ciperio River Downstream Sampling Location..... 5-35

Figure 5-25 Ally's Creek Sampling Location ..... 5-36

Figure 5-26 Land Use in San Fernando Wastewater Catchment..... 5-40

Figure 5-27 Dates and Locations of Sites Visited for Terrestrial Fauna Study ..... 5-43

Figure 5-28 Ciperio River in Concrete Channel at Grid Reference 668521mE, 1134820mN ..... 5-44

Figure 5-29 Ciperio River at Grid Reference 670148mE, 1134594mN..... 5-44

Figure 5-30 Mangrove Woodland North of the Guaracara River Accessed via Point-a-Pierre ..... 5-45

Figure 5-31 Mangrove Woodland South of Guaracara River Mouth..... 5-45

Figure 5-32 Mudflats at the Mouth of the Ciperio River. Viewed from Bel-Air 666301mE, 1134246mN ..... 5-46

Figure 5-33 Mudflats at the Mouth of the Vistabella River. Viewed from Boatyard at 668298mE, 1137924mN ..... 5-46

Figure 5-34 Sampling Locations for Aquatic Survey..... 5-48

Figure 5-35 Air and Noise Monitoring Stations in San Fernando Wastewater Catchment Area..... 5-79

Figure 6-1 Land Use in San Fernando Wastewater Catchment based on Human Activity..... 6-5

Figure 6-2 Archaeological Sites in San Fernando Wastewater Catchment..... 6-8

Figure 6-3 Status of Employment in San Fernando City Corporation (Central Statistical Office, 2002) ..... 6-10

Figure 6-4 General Occupational Groups (Central Statistical Office, 2002) ..... 6-11



Figure 6-5 Residents Employed within Industry Sector (Central Statistical Office, 2002) ..... 6-11

Figure 6-6 Recreational Places in San Fernando Wastewater Catchment..... 6-14

Figure 6-7 Number of Persons in Household, Social Survey 2010..... 6-16

Figure 6-8 Age-Sex Distribution in San Fernando City Corporation (Central Statistical Office, 2002) 6-17

Figure 6-9 Religious Composition of San Fernando Municipality (Central Statistical Office, 2002) 6-18

Figure 6-10 Ethnic Composition of San Fernando City (Central Statistical Office, 2002)..... 6-19

Figure 6-11 Ethnicity of Respondents of Social Survey 2010 ..... 6-19

Figure 6-12 Status of Schooling for the period 2000 (Central Statistical Office, 2002) ..... 6-20

Figure 6-13 Highest Educational Attainment (Central Statistical Office, 2002)..... 6-21

Figure 6-14 Highest Exam Level Passed (Central Statistical Office, 2002) ..... 6-21

Figure 6-15 Housing Material in Surveyed Areas ..... 6-22

Figure 6-16 Domestic Water Supply in San Fernando Wastewater Catchment..... 6-23

Figure 6-17 Domestic Water Supply in the City of San Fernando (Central Statistical Office, 2002) 6-23

Figure 6-18 Type of Facilities for Wastewater Disposal among Residents of the San Fernando Wastewater Catchment ..... 6-24

Figure 6-19 Number of Toilets in Household and Type of Disposal Systems for Wastewater in Dwellings within the San Fernando Wastewater Catchment ..... 6-24

Figure 6-20 Type of Toilet Facilities in the City of San Fernando (Central Statistical Office, 2002) 6-25

Figure 6-21 Type of Energy Source Connection in Project Area..... 6-26

Figure 6-22 Household Energy Sources in San Fernando City (Central Statistical Office, 2002) ..... 6-26

Figure 6-23 Residents in the City of San Fernando with Telephones (Central Statistical Office, 2002) 6-27

Figure 6-24 Residents in the City of San Fernando with Internet (Central Statistical Office, 2002).. 6-28

Figure 6-25 Type of School Persons Enrolled in the City of San Fernando (Central Statistical Office, 2002)..... 6-30

Figure 6-26 Length of Awareness of San Fernando Wastewater Project..... 6-33

Figure 6-27 Traffic Sampling Locations ..... 6-37

Figure 8-1 Area of Traffic Influence of Entrance to San Fernando WWTP ..... 8-18

## List of Tables

Table 1 San Fernando WWTP Effluent Criteria..... E-6

Table 2 Proposed Collection System Pipe Length by Subcatchment..... E-12

Table 3 Fecal Coliform Data (CFU/100ml) from River Quality Sampling..... E-15

Table 4 Land Use Categories in San Fernando Wastewater Catchment ..... E-16

Table 5 Fauna Survey Species Observed..... E-16

Table 6 Project-Environment Interaction with Affected Environment ..... E-17

Table 7 Summary of Impacts Pre-and Post Mitigation ..... E-18

Table 1-1 Team Member Details for EIA Study ..... 1-5

Table 2-1 Water Pollutant Parameters for Source Registration (First Schedule of WPR)..... 2-4

Table 2-2 Permissible Levels of Water Pollutant Parameters in Different Receiving Environments, WPR 2001 (as amended) ..... 2-5

Table 2-3 Prescribed Standards According to the First Schedule, NPCR..... 2-7



Table 2-4 Air Pollutant Concentration at WWTP .....	2-13
Table 2-5 Effluent Guidelines for WWTP.....	2-13
Table 2-6 Maximum Permissible Levels for Liquid Effluent from Domestic Wastewater Treatment Plants (TTS 417:1993) .....	2-18
Table 2-7 Permissible Limits for Effluent Discharge from Industrial Processes (TTS 547:1998) .....	2-19
Table 2-8 List of Multinational Agreements, Treaties and Conventions Ratified by Trinidad and Tobago.....	2-24
Table 3-1 Summary of Population Projections.....	3-6
Table 3-2 Existing Lift Stations and WWTPs in San Fernando Area .....	3-6
Table 3-3 Raw Wastewater Concentrations at the Existing San Fernando WWTP (2009) .....	3-11
Table 3-4 Sources of Septage for the Existing San Fernando WWTP .....	3-11
Table 3-5 Septage Volumes in 2008.....	3-12
Table 3-6 Typical Septage Concentrations.....	3-13
Table 3-7 Raw Wastewater Concentrations at Harmony Hall (2009).....	3-13
Table 3-8 Summary of Project Design Flows.....	3-14
Table 3-9 Average Design Loads for San Fernando WWTP .....	3-14
Table 3-10 San Fernando WWTP Effluent Criteria .....	3-16
Table 3-11 San Fernando Wastewater Treatment Plant Design Data .....	3-36
Table 3-12 New Collection System Pipe Length by Subcatchment.....	3-49
Table 3-13 Lift Station Information .....	3-67
Table 3-14 Lift Station Location Descriptions .....	3-68
Table 3-15 Phase I of Subcatchment Construction Information .....	3-69
Table 3-16 Additional Phases of Subcatchment Construction Information .....	3-71
Table 4-1 Advantages and Disadvantages of Option L1 .....	4-7
Table 4-2 Advantages and Disadvantages of Option L2 .....	4-9
Table 4-3 Advantages and Disadvantages of Option L3 .....	4-11
Table 4-4 Advantages and Disadvantages of Option L4 .....	4-12
Table 4-5 Advantages and Disadvantages of Option L5 .....	4-14
Table 4-6 Evaluation Criteria .....	4-14
Table 4-7 Rating Table of Options .....	4-15
Table 4-8 Conceptual Cost Comparison of Surface Aeration and Fine Bubble Aeration.....	4-17
Table 4-9 Advantages and Disadvantages of Option S1 .....	4-19
Table 4-10 Advantages and Disadvantages of Option S2 .....	4-20
Table 4-11 Advantages and Disadvantages of Option S3 .....	4-21
Table 4-12 Advantages and Disadvantages of Option S4 .....	4-22
Table 4-13 Advantages and Disadvantages of Option S5 .....	4-23
Table 4-14 Rating Table of Options .....	4-23
Table 5-1 List of Hurricanes and Tropical Storms Affecting Trinidad .....	5-9
Table 5-2 Grain Composition of Soil Units.....	5-14
Table 5-3 List of Borehole Sites for San Fernando Wastewater Collection System.....	5-17
Table 5-4 Geological Formation and Sedimentology.....	5-20
Table 5-5 River Flow Data at Ciperó River, Station Number 10803 (Water Resources Agency, 2010).....	5-24
Table 5-6 Results from Analysis of Water Samples from Guaracara River.....	5-27
Table 5-7 Results from Analysis of Water Samples from Marabella River.....	5-28



Table 5-8 Results from Analysis of Water Samples from Vistabella River ..... 5-29

Table 5-9 Results from Analysis of Water Samples from Cipero River ..... 5-30

Table 5-10 Results from Analysis of Water Samples from Ally's Creek ..... 5-31

Table 5-11 Water Quality Parameters That Decreased in Quality within the Catchment ..... 5-36

Table 5-12 Land Use Categories and Area in San Fernando Wastewater Catchment ..... 5-41

Table 5-13 Observed Habitats and Flora Species Observed ..... 5-42

Table 5-14 Locations Sampled for Aquatic Fauna Study ..... 5-47

Table 5-15 Amphibians and Reptiles Which May be Expected Within San Fernando and Environs 5-50

Table 5-16 Birds of Trinidad Likely to be Found Within San Fernando and Environs and the Habitats  
in Which They are Likely to be Found ..... 5-52

Table 5-17 Mammals of Trinidad Which May be Expected Within San Fernando and Environs..... 5-62

Table 5-18 Historical Records of Aquatic Species Found Within San Fernando and Environs ..... 5-63

Table 5-19 Butterfly Species Common or Abundant and Widespread in Trinidad and are Likely to  
Occur in the Greater San Fernando Area. .... 5-65

Table 5-20 Butterflies Observed Within San Fernando and Environs, October 2009 ..... 5-67

Table 5-21 Description of Fish Species Captured per Sample Station..... 5-68

Table 5-22 Bird Species Observed Within San Fernando and Environs, October 2009 ..... 5-70

Table 5-23 Sound Level Monitoring Results..... 5-80

Table 5-24 Average Leq and Lpeak Measurements for Noise Sampling..... 5-81

Table 5-25 TSP and PM2.5 Air Quality Results in San Fernando Wastewater Catchment ..... 5-82

Table 6-1 Subcatchments within Administrative Areas ..... 6-2

Table 6-2 New and Proposed Housing Developments in the San Fernando Wastewater Catchment... 6-6

Table 6-3 Classification of Archaeological Sites ..... 6-7

Table 6-4 Businesses in San Fernando Wastewater Catchment (Central Statistical Office, 2002) ..... 6-9

Table 6-5 Population Count by Regional Corporation ..... 6-15

Table 6-6 2009 Socio-Economic Status for San Fernando Project Area..... 6-28

Table 6-7 Health Centres in Project Area..... 6-29

Table 6-8 Preferred Price for Sewer Service (Quarterly Rate)..... 6-35

Table 6-9 Traffic Counting Results, March 23-25, 2010 ..... 6-38

Table 7-1 Schedule for Public Consultations and Stakeholder Meeting ..... 7-2

Table 7-2 Introductory Meetings held with Relevant Agencies ..... 7-3

Table 7-3 Questions and Answers from September 30, 2009 Meeting. .... 7-4

Table 7-4 Key Questions and Answers from January 26, 2010 Meeting ..... 7-5

Table 7-5 Key Questions and Answers from April 13, 2010 Meeting ..... 7-7

Table 8-1 Explanation of Terms Used in Impact Assessment..... 8-2

Table 8-2 Project-Environment Interaction with Affected Environment ..... 8-4

Table 8-3 Weekly Anticipated Traffic at San Fernando WWTP Site During Operation ..... 8-7

Table 8-4 Summary of Project Impacts and Mitigation Measures ..... 8-28

Table 8-5 Summary of Accident and Malfunction Impacts and Mitigation Measures ..... 8-39

Table 9-1 Monitoring Plan – Construction Phase..... 9-7

Table 9-2 Monitoring Plan – Operation Phase ..... 9-9





## Appendices

- Appendix A. Terms of Reference for Certificate of Environmental Clearance
- Appendix B. Legislative and Regulatory Framework
- Appendix C. Project Description
- Appendix D. Biophysical Baseline Data
- Appendix E. Socio-Economic Baseline Data
- Appendix F. Key Stakeholder and Public Consultations
- Appendix G. Impact Assessment and Mitigation Measures
- Appendix H. Environmental Monitoring and Management



# 1. Introduction

## 1.1 Overview

The Water and Sewerage Authority (WASA) of the Ministry of Public Utilities (MOPU) applied to the Environmental Management Authority (EMA) in August, 2006 for a Certificate of Environmental Clearance (CEC) for the establishment of a regional wastewater plant, inclusive of works, laying of sewer mains, and decommissioning of existing wastewater facilities in the city of San Fernando and environs. The project area is roughly bounded by the Guaracara River in the north, Solomon Hochoy Highway in the east inclusive of Ste. Madeline, developments inside of the M2 Ring Road in the south, and Gulf of Paria in the west.

The EMA adjudged the project to have significant environmental and social impacts and notified WASA that the CEC application could only be entertained after completion of an Environmental Impact Assessment (EIA) study conducted against specific terms of reference. Final Terms of Reference (TOR) were provided to WASA by the EMA on 21<sup>st</sup> November 2006 (Ref: CEC1597/2006) for the conduct of an EIA study (**Appendix A**).

## 1.2 Project Background

The city of San Fernando is the second largest urban centre in Trinidad. It is the commercial hub of south Trinidad and has been steadily expanding with the growth of the oil and gas sector and downstream activities in south Trinidad. The city of San Fernando's current population is approximately 55,400. The city is serviced by a wastewater collection, treatment and disposal system built in the 1960's and owned and operated by WASA. The collection system has approximately 72 km of piping, and services approximately 25,000, which is less than half of the city's population. The wastewater treatment plant, located adjacent to the Ciperu River at the west end of Riverside Drive, was originally designed to treat 20 ML/d. A septage receiving station was constructed at the San Fernando plant in the 1980's.

The wastewater system has functioned adequately for a number of years, but has passed its useful design life and is in need of major rehabilitation and expansion to meet the current and future needs of the city and surrounding areas. Field studies have revealed that sections of the existing collection system are in need of replacement as some visible sections of trunk sewer have broken open and fallen into drains and rivers, allowing untreated wastewater into the waterways.

The areas outside of the existing San Fernando collection system have experienced significant development over the past several years. The estimated population of the surrounding areas outside the city limits is approximately 47,600. Numerous private and government housing, commercial and institutional developments have emerged along with separate wastewater collection systems, pump stations and packaged wastewater treatment plants (WWTPs). Most of the outlying treatment facilities are not owned and maintained by WASA. These areas include Harmony Hall, Tarouba, Pleasantville, Palmiste, and Gulf View. In addition, approximately 70% of developed areas surrounding San Fernando are not sewerred. They are serviced by on-lot systems including septic tanks, soak-aways, and pit latrines. The conditions of these existing systems vary; however, the majority of the systems are not



functioning or only partially functioning, resulting in untreated or partially treated wastewater entering waterways.

### 1.3 San Fernando Wastewater Treatment Plant and Collection System

WASA intends to improve the wastewater sector in the city of San Fernando and environs by expanding the sewered service area and improving the level of wastewater treatment for existing and new customers in the rapidly developing area. The end result of the project will be an integrated wastewater system that provides a cost-effective and sustainable wastewater collection and treatment within the project boundaries. The main benefits of the project include:

- Reduction in public health risk associated with untreated wastewater discharges into drains, rivers and other water courses.
- Improvement of water quality in the Guaracara, Marabella, Vistabella and Cipero Rivers that currently receive wastewater discharges.
- Overall improvement to the surrounding environment through the proper collection, treatment and disposal of wastewater that is presently adversely affecting the environment.
- Potential for production of up to 45 ML/d of reclaimed water that is suitable for irrigation and other non-potable uses in the area.
- Overall improvement in the quality of life for the citizens of San Fernando and environs.

The San Fernando Wastewater project involves one integrated and centralized collection system and WWTP in the San Fernando and environs area. The project boundary as well as major roads and rivers are shown in yellow on Figure 1-1. The collection system design includes installation of new trunk sewers for conveying wastewater to the new WWTP, new local sewers to capture flow from properties that do not currently have sewer service, and connection of new and existing sewers into one integrated collection system. The new WWTP will replace the existing San Fernando WWTP, Harmony Hall WWTP, and several smaller plants previously installed by developers. The new WWTP will be located on the site of the existing San Fernando WWTP, at the western end of Riverside Drive, north of the Cipero River.



Figure 1-1 San Fernando Wastewater Project Area



With the implementation of the project, WASA will become the sole responsible Authority for wastewater treatment and disposal in the regional Catchment, and will be able to effectively monitor, regulate and control effluent discharged to the environment.

## 1.4 Scope of the EIA

The TOR for the conduct of this EIA study was provided to WASA by the EMA. A copy of the TOR is provided in **Appendix A**.

The scope of works for the project includes the following tasks as identified in the TOR:

- Conduct a literature review (including legislative requirements) of existing information in the public domain related to the proposed establishment of the wastewater treatment plants and associated works, as well as the areas adjacent to the proposed development area.
- Identify data gaps existing in the public domain that are pertinent to describing the biophysical and social environmental baseline that exists within the project affected area.
- Perform field surveys to collect social and environmental data to fill data gaps and establish baseline conditions.
- Determine potential environmental and social impacts of the proposed activity.
- Evaluate various project alternatives and justify the preferred alternative on the basis of technical, financial, environmental, social and planning requirements.
- Conduct consultations with all relevant stakeholders and members of the general public.
- Develop mitigation measures and strategies to manage any negative residual impacts of the project or maximize beneficial elements of the project.
- Develop a management plan for all phases of the project life.
- Develop a monitoring plan for the different phases of the project.

## 1.5 Report Structure

The EIA studies the nature and extent of environmental and social impacts that will arise from the construction and operation of one integrated wastewater collection system and treatment plant in the San Fernando area.

The EIA Report provides a set of recommendations throughout the assessment process, which have been included in the detailed design of the project, and are recommended for later phases of work to minimize any adverse impacts on the development and to maximize the practical benefits for the environment. A baseline assessment of the various environmental and social parameters, which resulted in the recommendations, is also presented.

The EIA Report is presented in the following format:

- |           |  |
|-----------|--|
| Section 2 | Legislative, Regulatory and Policy Framework |
| Section 3 | Project Description                          |
| Section 4 | Alternatives to Project                      |



Section 5	Biophysical Environmental Setting
Section 6	Social Environmental Conditions
Section 7	Key Stakeholder and Public Consultation
Section 8	Impact Analysis and Mitigation Measures
Section 9	Environmental Management and Monitoring Plan
Section 10	Bibliography

## 1.6 List of Report Preparers and EIA Project Team

The contract for the conduct of an EIA study for the proposed San Fernando Wastewater Project was established between WASA and AECOM. AECOM was also retained to conduct the detailed design of the WWTP and collection system. This work began in 2009.

Qualified personnel with expertise and experience contributed to the findings of this EIA. Each team member possesses a specific area of expertise in one or more of the disciplines needed for the completion of the EIA for this project.

The table below lists each team member and their years of experience within the respective fields.

**Table 1-1 Team Member Details for EIA Study**

Name of Preparer	Organization	Years of Experience
Jim Marx	AECOM	>30
Matt McTaggart	AECOM	>25
Stephen Biswanger	AECOM	>15
Alison Weiss	AECOM	>6
Natalie Wilson	AECOM	>4
Sara-Jade Govia	AECOM	>2
Kimlin Austin	WASA	>15
Graham White	Self employed	>30
Paul Comeau	Self-employed	>30
Elka Bachan	Environmental Sciences Limited	>6
Nadeera Supersad	Environmental Sciences Limited	>4
Erin Mangal	Environmental Sciences Limited	>8
Steffan Shageer	Environmental Sciences Limited	>4
Erna Kirk	Market Facts & Opinions	>16
Lucrecia Birch	Market Facts & Opinions	>10
Kimberly Philip	Market Facts & Opinions	>4



## 2. Legislative, Regulatory, and Policy Framework

### 2.1 Introduction

This section introduces the legislative, regulatory and policy framework of Trinidad and Tobago pertaining to the San Fernando Wastewater Project. The project will be subjected to the following as described in the report:

- Acts of Parliament
- Rules of Trinidad and Tobago
- Pertinent guidelines of the Water and Sewerage Authority
- Applicable Standards of other legislative authorities
- National policies
- Regional and international treaties ratified by the Government of Trinidad and Tobago

### 2.2 Environmental Management Act

The Environmental Management Act was passed in 2000 in the Trinidad and Tobago Parliament and was meant to repeal and re-enact the previous Environmental Management Act that was passed in 1995. The basic notion of the Act is to regulate the conservation and management of the environment. Specific objectives of the Act are:

- Promotion of the environment
- Integration of the environment in decision-making
- Establishment of integrated environmental management systems
- Development and integration of laws and policies
- Enhancement of the legal and regulatory framework for environmental management

The Act stipulated the establishment of the Environmental Management Authority (EMA) as the corporate entity that would be responsible for mandating specifics of this Act. The Environmental Management Act also specified the formation of the Environmental Commission, which is charged with enforcing the regulations and policies associated with the Act.

#### 2.2.1 Environmental Management Authority

The EMA was formed in 1995 when the initial Environmental Management Act was formulated. When this Act was revoked and modified in 2000, some of the roles and functions of the EMA changed. The responsibilities of the organization are as follows:

- Make recommendations for a National Environmental Policy
- Formulate and implement policies for environmental management
- Co-ordinate environmental functions
- Make recommendations for rationalising government agencies with environmental functions
- Promote public awareness of the environment
- Formulate and implement environmental standards
- Monitor compliance with environmental standards



- Take appropriate action to prevent and control pollution for environmental conservation
- Establish links to local, regional and international institutions
- Perform other prescribed functions
- Undertake any action pertinent to the functions of the Authority

As mandated in the Environmental Management Act, the EMA is charged with the responsibility of formulating rules for environmental management specifically in relation to sustainable development and pollution management in Trinidad and Tobago. Subsequently, the EMA has institutionalized the following legislation as one of the mechanisms to attaining integrated environmental management:

- Certificate of Environmental Clearance Rules
- Water Pollution Rules
- Noise Pollution Control Rules
- Draft Air Pollution Rules
- Environmentally Sensitive Areas Rules
- Environmentally Sensitive Species Rules
- Draft Waste Management Rules

Each regulation and the relevance to the San Fernando Wastewater project will be discussed in this section.

### 2.2.2 Certificate of Environmental Clearance Rules

The Certificate of Environmental Clearance (CEC) Rules was enacted in 2001 and amended both in 2007 and 2008. A document entitled the CEC (Designated Activities) Order was also formulated as part of the CEC Rules, 2001. This lists all the activities that may potentially require a CEC and therefore an application would be required prior to construction. The San Fernando Wastewater Project falls under the category of Activity 42 defined as:

- Establishment of wastewater or sewage treatment facilities: The establishment, modification, expansion, decommissioning or abandonment (inclusive of associated works) of a wastewater or sewage treatment facility.

The CEC Rules, 2001 explains the procedure for submitting a CEC application by the company or agent responsible for the specific development. The CEC application form generally requests details on the nature and purpose of the activity, description of the processes involved, specifics on waste handling and storage of hazardous substances and an explanation of the natural environment at the proposed site.

According to the CEC Rules the application must be submitted to the Town and Country Planning Division (TCPD) in the respective location of the site. This is to ensure coordination among government entities and that the development fulfils the requirements of the Town and Country Planning Act as discussed in Section 2.12.2. The application is passed onto the EMA for processing.

The EMA then reviews the application and conducts a field visit to the proposed site with the applicant if necessary. Within ten working days of receipt of the application the EMA submits official notification of the decision made for granting the CEC, which may be:





- No CEC required since the development does not fall into any of the categories as listed in the CEC (Designated Activities) Order.
- A request for more information.
- A CEC is required but an EIA does not have to be conducted.
- An EIA is required for the CEC to be granted and it must fulfil the Terms of Reference (TOR) set by the EMA.
- A decision on a claim for confidentiality where it was requested by the applicant.

Where an EIA is required, members of the public are allowed to examine the contents of the final EIA report and submit comments to the EMA. In some situations other relevant government and corporate entities assist the EMA in the evaluation of the EIA. A decision is then made by the EMA on whether a CEC would be granted or refused.

The CEC application for the San Fernando Wastewater Project was submitted by WASA to follow the regulations stipulated in the CEC Rules, 2001. The EMA concluded that this project requires a CEC and an EIA is necessary for making a decision on the application. The TOR was developed by the EMA as discussed in Section 1.

### 2.2.3 Water Pollution Rules

The Water Pollution Rules (WPR) were enacted in 2001 and amended in 2006. The WPR stipulated the compilation of a Register of Water Pollutants that lists all the facilities that discharge into the environment and the characteristics of the water pollutant discharged.

According to the WPR a company or individual that releases a substance that may be hazardous to human health and the environment must submit a source application to the EMA prior to discharge of the substance. If the water pollutant is discharged into the environment outside of the permissible levels as dictated by the WPR a permit is required.

The application procedure for source registration includes a description of the process producing the water pollutant, volume and rate of release of the substance, effluent quality, releasing environment characteristics and details of any water pollution control programme.

The WPR outlines the parameters for water pollutants that are to be registered by the emitter. This is the First Schedule of the WPR as displayed in Table 2-1.

**Table 2-1 Water Pollutant Parameters for Source Registration (First Schedule of WPR)**

Parameter	Quantity at Which Substance is Defined a Pollutant
Temperature	Max. variation of 3°C from ambient
pH	<6 or >9
Dissolved Oxygen	<4
5-day Biological Oxygen Demand	>10
Chemical Oxygen Demand	>60
Total Suspended Solids	>15
Total Oil and Grease	>10
Ammoniacal Nitrogen	>0.01
Total Phosphorus	>0.1
Sulphide	>0.2
Chloride	>250
Total Residual Chlorine	0.2
Dissolved Hexavalent Chromium	>0.01
Total Chromium	>0.1
Dissolved Iron	>1
Total Petroleum Hydrocarbons	No increase above ambient
Total Nickel	>0.5
Total Copper	>0.01
Total Zinc	>0.1
Total Arsenic	>0.01
Total Cadmium	>0.01
Total Mercury	>0.005
Total Lead	>0.05
Total Cyanide	>0.01
Phenol	>0.1
Radioactivity	No increase above ambient
Toxicity	No acute toxic effects
Faecal Coliform	>100
Solid Waste	No solid debris

Note: all units are in milligrams per litre (mg/L), except for temperature (°C), pH (pH units), Faecal Coliforms (counts per 100 ml), radioactivity (Bq/L), and toxicity (toxic units).



The Second Schedule of the WPR outlines the permissible levels for water pollutants that require a permit for discharge. The parameters are defined for different receiving environments. These are categorized as follows:

- Inland Surface Water – rivers, creeks, tidal waters, estuaries, swamps, streams, lakes, impounding reservoirs, area which waters flowed but have evaporated in dry conditions.
- Coastal Nearshore – marine environment 3 nautical miles or less from the high water mark.
- Marine Offshore – marine environment seaward of the coastal nearshore zone.
- Environmentally Sensitive Area – defined in Section 2.2.6.
- Groundwater – water below the earth’s surface.

The effluent of the new San Fernando WWTP would be discharged into the Cipro River, which is categorised as “Inland Surface Water”. The effluent quality would need to meet the criteria represented in Table 2-2 under Inland Surface Water.

**Table 2-2 Permissible Levels of Water Pollutant Parameters in Different Receiving Environments, WPR 2001 (as amended)**

Water Pollutant Parameter	Receiving Environment			
	Inland Surface Water	Coastal Nearshore	Marine Offshore	ESA and/or Groundwater
Temperature	35	40	45	No increase above ambient
Dissolved Oxygen	>4	>4	>4	>4
pH	6-9	6-9	6-9	6-9
5-day Biological Oxygen Demand	30	50	100	10
Chemical Oxygen Demand	250	250	250	60
Total Suspended Solids	50	150	200	15
Total Oil and Grease	10	15	100	No release
Ammoniacal Nitrogen	10	10	10	0.1
Total Phosphorus	5	5	5	0.1
Sulphide	1	1	1	0.2
Chloride	250	No increase above ambient	No increase above ambient	No increase above ambient
Total Residual Chlorine	1	1	2	0.2
Dissolved Hexavalent Chromium	0.1	0.1	0.1	0.01
Total Chromium	0.5	0.5	0.5	0.1



**Table 2-2 Permissible Levels of Water Pollutant Parameters in Different Receiving Environments, WPR 2001 (as amended) (continued)**

Water Pollutant Parameter	Receiving Environment			
	Inland Surface Water	Coastal Nearshore	Marine Offshore	ESA and/or Groundwater
Dissolved Iron	3.5	3.5	3.5	1
Total Petroleum Hydrocarbons	25	40	80	No release
Total Nickel	0.5	0.5	0.5	0.5
Total Copper	0.5	0.5	0.5	0.01
Total Zinc	2	2	2	0.1
Total Arsenic	0.1	0.1	0.1	0.01
Total Cadmium	0.1	0.1	0.1	0.01
Total Mercury	0.01	0.01	0.01	0.005
Total Lead	0.1	0.1	0.1	0.05
Total Cyanide	0.1	0.1	0.1	0.01
Phenol	0.5	0.5	0.5	0.1
Radioactivity	No increase above ambient	No increase above ambient	No increase above ambient	No increase above ambient
Toxicity	No acute toxic effects	No acute toxic effects	No acute toxic effects	No acute toxic effects
Faecal Coliforms	400	400	400	100
Solid Waste	No solid debris	No solid debris	No solid debris	No solid debris

Note: all units are in milligrams per litre (mg/L), except for temperature (°C), pH (pH units), Faecal Coliforms (counts per 100 ml), radioactivity (Bq/L), and toxicity (toxic units).

ESA: Environmentally Sensitive Area

### 2.2.4 Noise Pollution Control Rules

The Noise Pollution Control Rules (NPCR) was formulated in 2001 by the EMA to regulate noise pollution in Trinidad and Tobago. The NPCR specifies the permissible sound levels for different environments. According to the rules, a person or company that intends to conduct an activity or event that will emit sound above the permissible level must submit an application for a noise variation.



This application must be completed four weeks before the event and a notice must be published in a national newspaper. A similar procedure applies for a noise variation for a facility; however, the application must be submitted ten working days prior to commencement of operation of the facility.

The NPCR outlines the different noise zones based on the type of activity undertaken in the area. These are defined as follows:

- Zone I – Industrial Areas: an area approved for industry by a governmental entity.
- Zone II – Environmentally Sensitive Areas: defined in Section 2.2.6.
- Zone III – General Areas: all other areas except industrial and environmentally sensitive areas.

The permissible sound levels for each zone are defined in the First Schedule of the NPCR. The San Fernando WWTP is located within an Industrial Zone according to the Town and Country Planning Division. The permissible sound pressure levels according to the First Schedule are presented in Table 2-3.

**Table 2-3 Prescribed Standards According to the First Schedule, NPCR**

Zone	Time of Day	Sound Pressure Level
I	Anytime	Equivalent continuous sound pressure level of 75 dBA. Instantaneous unweighted peak sound pressure level of 130 dB. No sounds emitted should exceed 60 dBA.
II	Day-time	Equivalent continuous sound pressure level of 3 dBA, above background. Instantaneous unweighted peak sound pressure level of 120 dB.
	Night-time	Equivalent continuous sound pressure level of 3 dBA above background. Instantaneous unweighted peak sound pressure level of 115 dB.
	Anytime	No sounds emitted should exceed 60 dBA.
III	Day-time	Equivalent continuous sound pressure level of 5 dBA above background; not to exceed 80 dBA. Instantaneous unweighted peak sound pressure level of 120 dB.
	Night-time	Equivalent continuous sound pressure level of 5 dBA above background; not to exceed 65 dBA. Instantaneous unweighted peak sound pressure level of 115 dB.

The Second and Third Schedule of the regulation defines how sound pressure levels should be recorded and reported (**Appendix B.1**). The method by which the meter should be calibrated is also described in the NPCR. Generally, sound is measured at the property line of the complainant or that of the sound emissions. In cases of a noise complaint, the sound at the property line of the activity is used to determine if the level is beyond the permissible limits.

Some activities are exempt from abiding by the standards of the NPCR pertinent to the San Fernando Wastewater Project are:

- Sound associated with the installation, repair or replacement of public utilities in a public place between the hours of 7:00 am and 11:00 pm of the same day.



- Construction activity when conducted on a construction site between the hours of 7:00 am and 7:00 pm of the same day.

The guidelines of the NPCR will be followed when constructing and operating the San Fernando WWTP and Collection System.

### 2.2.5 Draft Air Pollution Rules

The Draft Air Pollution Rules (APR) were formulated in 2005 and are yet to be enacted by the Government of Trinidad and Tobago. The APR outlines the procedure for registering a source emitter and obtaining a permit for releasing air pollutants. A source emitter is defined as a person or operator of a facility that releases an air pollutant into the atmosphere.

The activities that have potential to emit air pollutants are defined in the First Schedule of the APR. The operation of a wastewater treatment plant falls under Category 12, “Waste Handling”. The Activity is “Waste Treatment and Disposal” the APR describes the San Fernando WWTP under Description 4, “Treatment Works Emissions”.

According to the APR, an air pollutant is any substance released in excess of the permissible levels as listed in the Second and Third Schedule. The Second Schedule classifies the maximum levels for non-point sources where the exact location or stack is undefined (**Appendix B.2**). Vehicular emissions are not categorised as non-point sources according to the APR.

The Third Schedule of the APR presents the stack release limits of substances considered air pollutants. The design of the new San Fernando WWTP does not include any vertical pipe where emissions would be released therefore the regulations would not apply to this project.

### 2.2.6 Environmentally Sensitive Areas Rules

The Environmentally Sensitive Areas (ESA) Rules were formulated in 2001 as part of the mandate of the EMA to protect and conserve the natural resources and environment of Trinidad and Tobago. The purpose of the ESA Rules is to ensure that specific activities are not undertaken in defined areas. According to the rules, an ESA is characterised by the following criteria:

- The actual or prospective habitat of an Environmentally Sensitive Species (ESS), which is defined in Section 2.2.7.
- An area defined in any of the international conventions ratified by the government of Trinidad and Tobago. Mention is made of these agreements in Schedule I of the ESA Rules, including:
  - The Convention for the Protection of Development of Marine Environment of the Wider Caribbean Region (1986).
  - The Specially Protected Areas and Wildlife Protocol (1990).
  - The Convention on Wetlands (1993).
  - The United Nations Framework Convention on Climate Change (1994).
  - The United Nations Convention on Biological Diversity (1996).
- An area that falls into the category defined in the Guidelines listed in Schedule II of the ESA Rules.



- An area referred in any of the written laws of Trinidad and Tobago (**Appendix B.3**).

A legal notice must be advertised by the EMA before an area is declared an ESA. The notice will provide details on the precise location and boundaries of the ESA, the reasons for designation, specifics on the use and type of activities that can be carried out within the ESA and any mitigation measures that can be undertaken to restore the environment.

To date the Aripo Savannas, Nariva Swamp and Matura National Park have been designated as ESAs. None of these areas are within the boundaries of the San Fernando Wastewater Project.

### 2.2.7 Environmentally Sensitive Species Rules

The Environmental Management Act states that the EMA is also responsible for the protection of endangered species within Trinidad and Tobago. The Environmentally Sensitive Species (ESS) Rules were enacted in 2001 to legislate the protection of plant and animal species in their natural environment.

The following criteria guide the designation of an ESS:

- A species indigenous to Trinidad and Tobago.
- A species in danger of extinction.
- A species defined in any of the international conventions ratified by the government of Trinidad and Tobago. These agreements are listed in Schedule I of the ESS Rules, they include:
  - The Convention on International Trade in Endangered Species of Wild Fauna and Flora (1984).
  - The Specially Protected Areas and Wildlife Protocol (1990).
  - The Convention on Wetlands (1993).
  - The United Nations Convention on Biological Diversity (1996).
- An area that falls into the category defined in the Guidelines listed in Schedule II of the ESS Rules.
- An area referred in any of the written laws of Trinidad and Tobago.

Similar to the ESA Rules a legal notice must be provided by the EMA describing the species, natural habitat, reasons for the designation, limitations on the use of the species and mitigation measures for protecting the species and its habitat.

Included in the regulation are the activities that are prohibited when an ESS Notice is submitted. In terms of living plant species, the organism cannot be disturbed or destroyed by picking, collection, cutting, uprooting or possession of trade. With respect to living animal species, the organism cannot be hunted, traded or disturbed during the breeding, incubation, estivation or migratory phases. The ESS Rules exempt the captive breeding and propagation of the environmentally sensitive animal or plant species.

The Pawi (*Pipile pipile*), White-tailed Sabrewing Hummingbird (*Campylopterus ensipennis*) and West Indian Manatee (*Trichechus manatus*) have been named ESS by the EMA to date. The EMA is also



proposing that the Golden Tree Frog (*Phyllodytes auratus*) and the Ocelot (*Leopardus pardalis*) be designated as ESS.

The species mentioned above have not been found during the biophysical investigations of the San Fernando Wastewater Project area nor has it been historically recorded that these ESS inhabited any part of the project area. The legislation is therefore not applicable to this project but will still be carefully considered when undertaking construction and operation of the San Fernando WWTP and Collection System.

### 2.2.8 Draft Waste Management Rules

The Draft Waste Management Rules were drafted in 2008 by the EMA. The Environmental Management Act stipulates that the EMA is responsible for implementing a programme for management of waste and establishing appropriate guidelines for the handling and disposal of waste.

The rules refer to the following activities as a method by which waste management can be regulated:

- Registration of waste generation facilities.
- Waste Handling Permits.
- Waste Facility License.

The Draft Waste Management Rules define how waste should be transported, the storage of waste, import and export of waste, guidelines for landfills and waste incineration and the establishment of a Waste Management Register.

Hazardous waste is categorised into the rules by specific substances, characteristics of the substance and certain substances that have particular hazardous characteristics.

## 2.3 Water and Sewerage Act

The Water and Sewerage Act was passed in 1965 by the Government of Trinidad and Tobago. This legislation specified the details on the administration of the water and sewerage infrastructure of the country through the establishment of the authorising body, the Water and Sewerage Authority (WASA).

With respect to the San Fernando Wastewater Catchment Project, the Water and Sewerage Act stipulates that WASA is responsible for:

- Maintenance and upgrade of the existing sewerage system.
- Maintenance and upgrade of sewage works.
- Constructing and developing required sewage infrastructure.
- Administering the sewerage services.

The Water and Sewerage Act defines WASA's duty to construct and maintain the sewage services in accordance with the sanitary rules of the Public Health Ordinance. To fulfil this function WASA is allowed to do the following:





- Construct sewers in streets and houses.
- Install pumps, machinery and other associated sewer equipment.
- Employ contractors to carry out the construction, installation and repair of all sewerage infrastructure works.

WASA is allowed by the Act to separate any area within Trinidad and Tobago into sewer or wastewater catchments. WASA also has the power to give notice to any property owner that they are required to construct a water closet if none exists on the property and/or connect to any existing or proposed sewer mains or pipes. This regulation can only be enforced if the property has a sufficient water supply and if the collecting sewer is within 150 feet (approximately 46 m) of the house or building.

According to the Water and Sewerage Act, all persons or businesses must submit drawings and plans for the sewer system of the property to WASA prior to commencement of construction. These plans would be subject to the approval of the Authority and must therefore tie into any existing or proposed sewer mains.

The Act addresses issues with construction of the sewerage infrastructure including laying of sewer mains in roadways and footpaths. WASA or the contractor undertaking the sewage works must consult with the agency or person in charge of the road or foot trail. In the San Fernando Catchment area this would be the Regional and City Corporations and a few private owners. WASA or the contractor must give notice of the intention of the construction and time of commencement of works. In the case of roadways seven days notice is required and for footpaths 3 days notice is the maximum time for a notice to be issued.

The Water and Sewerage Act stipulates that WASA or the contractor employed must:

- Repair road or footpath to the standards of the agency in control and this must be done up to 3 months subsequent to completion of the works.
- Dispose of all garbage and waste from the construction.
- Implement a proper traffic mitigation plan.
- Ensure area is fenced, guarded and lighted if the trench is left open. Suitable arrangements must also be made to control traffic caused.

In addition, the Act states that the property owner or the person residing in the building is responsible for all costs associated with installing and repairing sewer connections. This fee if not paid prior to construction would be recovered as a civil debt.

The Water and Sewerage Act specifies that WASA can make laws to standardise the construction of sewer infrastructure and the materials that can be used. These rules can also be used to regulate the substance that can be deposited into the sewer system and define the person that is accountable for handling the costs to fix water closets and install or repair sewer connections. WASA is in the process of formulating some of the standards in the “Water and Wastewater Design Guideline Manual”, which was produced in March 2009. The specifications of this document are discussed in Section 2.3.1.



### 2.3.1 WASA – Water and Wastewater Design Guidelines

In March 2009 WASA produced Revision 1 to the Water and Wastewater Design Guideline Manual. This document is intended to be used as a map for the design of all water and wastewater infrastructure in Trinidad and Tobago. The manual refers to design specifications of wastewater collection systems and wastewater treatment plants, in particular, flows and loads, pipe material and sizes and electrical, mechanical, architectural and structural standards.

WASA has not yet officially adopted the document as a design manual for the works conducted by or on behalf of the Authority; however, it still can be used to guide the design specifications in the interim. The general design standards, wastewater effluent treatment standards, water reuse standards and septage and biosolids management will be discussed in this section since it is a foundation for the design guidelines that have been adopted by WASA for the San Fernando Project.

#### 2.3.1.1 General Design Guidelines

The WASA Water and Wastewater Design Guideline Manual highlights mandatory standards that have to be applied to all water and wastewater design projects undertaken by consultants. It includes material standards (**Appendix B.4**), codes and other design criteria that must be followed and flood proof design standards for WASA buildings and structures. Generally, the Manual outlines that the standards of the American Society for Testing and Material (ASTM) and American Water Works Association (AWWA) must be followed when designing and constructing all water and wastewater infrastructure.

The manual highlights the design specifications for the wastewater collection system such as; design flows, pipe sizes, pipe slopes, manhole distances, pipe material and sewer connections. The document does not particularly require the engineer to follow all the specifications but it is expected to guide the design of the collection system.

The WWTP and pump station design is also addressed in the Water and Wastewater Design Guideline Manual. The guidelines were formulated as a means of ensuring that the design of these structures are carried out sustainably and malfunctions are prevented as much as possible. The plant layout must allow room for future expansion of the facility and to utilize space adequately. The piping in the WWTP must be arranged so that if one unit is out of operation the facility can continue to function.

In terms of environmental effects, the manual speaks to different factors including wastes from the treatment process. Any waste created must be appropriately stored for re-treatment or transported to another treatment facility. Odour control must be addressed at the design stage of the WWTP and hydrogen sulphide gas detectors must be installed. The concentration of air pollutants according to the manual is presented in Table 2-4.

**Table 2-4 Air Pollutant Concentration at WWTP**

Air Pollutant	Concentration (mg/Nm <sup>3</sup> )
Hydrogen Sulphide (H <sub>2</sub> S)	<0.1
Amines	<0.07
Ammonia	<1
Mercaptans	<0.7

Odour control must be installed at the pump stations and has to cover a radius of 100 metres within residential areas.

Stormwater management is also summarised in the manual and requires that the WWTP be designed to reduce run-off at the facility. The WWTP must be designed to structurally withstand ground movement and a monitoring plan should be carried out upon completion of the facility. Commonly, monitoring stations should be located at the influent, effluent and after each unit treatment.

*2.3.1.2 Wastewater Effluent Treatment Guidelines*

The treatment guidelines present the effluent quality criteria for WWTPs. The guideline for the effluent are based on the Water Pollution Control Rules and modified to reflect stricter criteria. The manual states that secondary treatment is necessary to achieve the effluent criteria. It also gives the conditions for tertiary treatment and stipulates that the disinfection process is mandatory in all cases. The effluent standards dictated in the manual are presented in Table 2-5.

The San Fernando Wastewater Treatment Plant is designed to meet a higher effluent guideline than shown in Table 2-5 for inland surface water. Refer to Section 3 of this report.

**Table 2-5 Effluent Guidelines for WWTP**

Discharge Point	BOD (mg/L)	Suspended Solids (mg/L)	pH	Faecal Coliform (MPN/100 ml)	Total Residual Chlorine (mg/L)	Ammoniacal Nitrogen (mg/L)	Total Phosphorus (mg/L)
Inland Surface Waters	20	20	6 – 9	400	1	10	5
Inshore Sea Waters	50	150	6 – 9	400	1	10	5
Offshore Sea Waters	100	200	6 – 9	400	2	10	5
Environmentally Sensitive Areas	10	15	6 – 9	100	0.2	0.1	0.1

*2.3.1.3 Water Reuse Guidelines*

The Manual refers to the reuse of treated effluent for irrigation purposes. The document states that the effluent must have undergone tertiary treatment before it can be re-used for agricultural activities. The



design of the WWTP can encompass the re-use of the treated effluent for watering plants close to and within the WWTP.

#### 2.3.1.4 *Septage and Biosolids Management*

Septage collected from septic or holding tanks, as well as pit latrines will be treated at the San Fernando WWTP. The Manual allows the use of stabilisation lagoons for the treatment of septage; however, a thorough investigation of soil and hydrogeological conditions must be conducted to suitably site the lagoons. The area positioned for the stabilisation lagoons or ponds should be properly fenced and a sign indicating the presence of a sewage pond must be used according to WASA's Design Manual.

Stabilization lagoons are not proposed as part of the design of the San Fernando WWTP. A septage receiving station is proposed to receive incoming septage and treat it in the new WWTP. The design is addressed in Section 3 of this report.

Biosolids will be produced at the proposed San Fernando WWTP when stabilized solids are removed from the aerobic digesters. Based on the Manual, the Biosolids can be thickened and disposed through one of the following methods:

- For agricultural purposes as nutrient sources.
- Dewatered and disposed at an appropriate landfill site.
- Dewatered and turned into pellets for farming.
- Dewatered, dried and incinerated to be used as an energy source at the WWTP.

The manual describes sludge drying beds as an option for this treatment. The design must consider average rainfall, humidity, liquid runoff, and provisions for heavy rainfall events by covering the beds, accelerating the dewatering process, extra storage facilities or alternate dewatering methods.

Sludge drying beds are not proposed as part of the design of the San Fernando WWTP. The design of the solids processing system is discussed in Section 3 of this report.

## 2.4 Forest Act

The Forest Act was enacted in 1916 and amended on several occasions subsequent to that, with the most recent amendment in 1999. The Act refers largely to the felling, burning and transporting of timber without permission. Timber is defined as any tree listed in the Second Schedule of the Act whether they are standing, fallen, living or dead (**Appendix B.5**). The following activities are prohibited within the designated Forest Reserves:

- Cattle grazing or trespassing.
- Felling, cutting, girdling, marking, lopping, tapping, bleeding, injury by fire of timber.
- Dragging or cutting of timber that may result in damage to other trees.
- Alights any fires outside of the periods allocated by the relevant authorities.
- Removing forest produce in designated areas.
- Entering a prohibited area.



The Act designates protected forested areas called Forest Reserves, these include:

- Mount Hope Estate
- Caroni Swamp

No part of the San Fernando Project area has been designated as a Forest Reserve therefore the regulations pertinent to Forest Reserves in the act would not be applicable for this project.

## 2.5 Fisheries Act

The Fisheries Act was passed in 1916 and no amendments have been issued to date. The term fish in the Act is defined as follows:

- Oysters
- Shrimps
- Turtles
- Corals
- Other marine fauna

The areas covered in the Fisheries Act include all rivers and territorial seas defined according to other laws of Trinidad and Tobago.

The Act addresses different issues with reference to the capture, sale and trade of fish. Generally the Act depicts the method by which fish can be caught and the equipment that can be used (**Appendix B.6**). The use of poison or explosives to injure or kill fish is prohibited according to this regulation. The size and type of fish species that cannot be captured and as a result sold or manufactured are also mentioned in the Act.

According to the Fisheries Act no fish or shellfish can be taken in certain areas. In the San Fernando Wastewater Project area, the body of water between Claxton Bay and the mouth of the Ciperu River is prohibited for taking any fish. This regulation also includes the capture of oysters, crabs and shrimps.

The protection of turtles also falls under this legislation. The rule refers to the capturing or killing of turtles in different coastal areas. According to the Act, it is illegal to kill or capture a turtle between the periods of March 1<sup>st</sup> to September 30<sup>th</sup>. Even though the project does not entail any fishing activities, the baseline environmental study included a fish survey. The method by which the fishes were captured abided by this regulation and is described in **Appendix D.5**.

## 2.6 Plant Protection Act

The Plant Protection Act was enacted in 1975 and amended in 2001. The general notion of the Act is to regulate the importation of plant species that would impact on local plants species. The regulation also seeks to protect local plant species from infection by plant pests that may have been transported during the importation of the foreign plant species. The plants that would be used for landscaping of the San Fernando Wastewater Treatment Plant would follow all the regulations stipulated in this act and would ensure that the plants are permitted and registered with the relevant authorities.



## 2.7 Conservation of Wildlife Act

The Conservation of Wildlife Act was enacted in 1963 to regulate the hunting and gaming procedures of Trinidad and Tobago. The Act refers to the granting of permits and the activities that could be undertaken with a State Game License or Resident's License. Hunting seasons and gaming sanctuaries are also assigned in this act. The closest gaming sanctuaries according to the First Schedule are:

- Southern Watershed Game Sanctuary:
  - Northern boundary; southern watershed reserve
  - Eastern boundary; Morne Diablo Road
  - Western boundary; Sea
  - Southern boundary; Quinam Road
- Morne l'Enfer Game Sanctuary:
  - Northern boundary; Forest Reserve Main Road
  - Eastern boundary; Bungalow and No. 20 Roads
  - Western boundary; Blue Basin and No. 31 Roads
  - Southern boundary; New Camp Road

Persons with a Resident's License are entitled to hunt animals for scientific research, zoology records or eradication of animals designated as vermin. The Third Schedule of the Act specifies the animals that are considered vermin or pests to the local habitats and the Second Schedule lists all animals that can be hunted in gaming sanctuaries during hunting seasons. These schedules are attached in **Appendix B.7**.

## 2.8 Occupational Safety and Health Act

The Occupational Safety and Health (OSH) Act was passed in 2004 by the Government of Trinidad and Tobago. The Act lists a wastewater treatment plant as a factory where it is defined as "premises in which persons are employed to supply and maintain services in connection with water and sewer". State-owned establishments are not exempt from abiding by the regulations of this act nor any work carried out on behalf of the State nor work conducted that is vital to national welfare.

The OSH Act stipulates the duty of the employer to ensure the safety and welfare of all employees. The services that the employer must provide include:

- Provision and maintenance of equipment used on site.
- Ensuring risks to health are prevented in terms of machinery and substances at the site.
- Provision of protective clothing and devices.
- Provision of information and training to ensure the safety of employees.
- Ensuring risks to health are prevented with relation to entrance and exit to the site.
- Ensuring risks to health are prevented in connection with amenities.
- A policy statement on safety and health of the employees.



The Contractor employed to conduct work on behalf of WASA must formulate an emergency plan that will comprise details on first aid help, transportation from the site to the nearest hospital or health centre, the measures taken to control a fire, evacuation scheme and methods by which appropriate personnel are notified.

As a result of the OSH Act, an OSH Authority governs and oversees the compliance of this legislation. A Chief Inspector will be assigned whose responsibility is to investigate and visit the workplace to ensure the employers abide with these rules. In some cases, the Chief Inspector can ask the employer to appoint a Safety Practitioner within the establishment who would ensure compliance to the OSH Act.

The OSH Act mentions not only the responsibility of the employer to ensure the safety of the workers but also to the employees. Employees have a duty to care for their own safety and those of the persons around them. The employee must also follow all responsibilities assigned by employer including the use of protective clothing and devices and any breach of the OSH Act must be reported by the employee to the employer.

Mention is also made of technology and machinery in the OSH Act. The designers, employers and employees must be aware of the risk of operating it and the liability as a result of improper installation. Specifics of certain machinery and equipment are also highlighted in the Act.

Fire emergency and response is addressed in the OSH Act. This is relevant to the San Fernando Wastewater Project since any establishment that “stores substances that are explosive or highly flammable” is subjected to the regulations regarding fire in the Act. The employer must ensure that the building is certified by the Fire Authority and an appropriate fire escape is installed. Based on the number of employees; warning signs, evacuation drills and fire equipment training must be carried out.

There are other basic amenities that must be provided by the employer at the treatment plant. These include; an adequate supply of drinking water, lockable washing facilities and changing rooms for men and women separately, first aid and a lunch or rest room. According to the Act, these facilities must be installed by law and are included in the WWTP design.

## 2.9 Trinidad and Tobago Bureau of Standards

The Trinidad and Tobago Bureau of Standards was made law in 1997 when the Standards Act was passed in the Government of Trinidad and Tobago. This act mandated that the Bureau develop and establish standards that;

- Improve goods produced in Trinidad and Tobago.
- Ensure industrial efficiency and development.
- Promote public and industrial welfare, health and society.
- Protect the environment.

As part of the scope of the organization two standards have been formulated to protect the environment from industrial and domestic waste; the specification for the liquid effluent from domestic wastewater



treatment plants into the environment, and the specification for the effluent from industrial processes discharged into the environment.

### 2.9.1 Specification for the Liquid Effluent from Domestic Wastewater Treatment Plants into the Environment

This standard coded TTS 417:1993 was formulated to prevent pollution and regularise the discharge of effluent into the environment. The standard outlines permissible levels for different parameters in varied environments. Environmentally sensitive areas are also considered in the standard and are defined by the ESA Rules as discussed in Section 2.2.6 they also include the following areas:

- Recreational waters
- Irrigation waters
- Waters used as a food source and for a potable supply
- Waters that impact on human health

Table 2-6 presents the limits of these parameters as stated in the standard for liquid effluent from domestic wastewater treatment plants.

**Table 2-6 Maximum Permissible Levels for Liquid Effluent from Domestic Wastewater Treatment Plants (TTS 417:1993)**

Parameter	Receiving Environment			
	Inland Surface Water	Inshore Marine Areas	Offshore Marine Areas	Environmentally Sensitive Areas
5-day BOD (mg/L)	25	25	175	25
Suspended Solids (mg/L)	30	30	175	30
pH	6 - 9	6 - 9	6 - 9	6 - 9
Faecal Coliforms (CFU/ 100 ml)	4000	4000	4000	400
Total Residual Chlorine (mg/L)	0.1	0.1	0.1	0

### 2.9.2 Specification for the Effluent from Industrial Processes Discharged into the Environment

This specification is another means by which the Bureau of Standards promotes environmental protection. This standard coded TTS 547:1998 lists the voluntary criteria for the discharge of effluent into the environment. This specification would still be applicable to the San Fernando Wastewater Project because it defines the permissible parameters of the wastewater discharged from industries in the San Fernando area. Table 2-7 depicts the maximum levels for each parameter when wastewater is discharged into different receiving environments.



**Table 2-7 Permissible Limits for Effluent Discharge from Industrial Processes (TTS 547:1998)**

Parameter	Receiving Environment			
	Inland Surface Water	Inshore Marine Areas	Offshore Marine Areas	Environmentally Sensitive Areas
5-day BOD (mg/L)	30	50	100	10
COD (mg/L)	250	250	250	60
TSS (mg/L)	50	150	250	15
n-Hexane Extractable Material (mg/L)	10	15	100	0
Ammoniacal Nitrogen (mg/L)	10	10	10	0.01
Phosphorus (mg/L)	5	5	5	0.1
Sulphide (mg/L)	1	1	1	0.2
Chloride (mg/L)	250	-	-	250
Total Residual Chlorine (mg/L)	1	1	2	0.2
Hexavalent Chromium (mg/L)	0.1	0.1	0.1	0.1
Total Chromium (mg/L)	0.5	0.5	0.5	0.1
Iron (mg/L)	3.5	3.5	3.5	1
Nickel (mg/L)	0.5	0.5	0.5	0.5
Copper (mg/L)	0.5	0.5	0.5	0.01
Zinc (mg/L)	2	2	2	0.1
Arsenic (mg/L)	0.1	0.1	0.1	0.05
Cadmium (mg/L)	0.1	0.1	0.1	0.01
Mercury (mg/L)	0.01	0.01	0.01	0.005
Lead (mg/L)	0.1	0.1	0.1	0.05
Cyanide (mg/L)	0.1	0.1	0.1	0.01
Phenol (mg/L)	0.5	0.5	0.5	0.1
Faecal Coliforms (CFU/100 ml)	400	400	400	100

## 2.10 National Policies

The Government of Trinidad and Tobago has implemented a number of national policies, some are still in the draft stage. These national policies are meant to guide decision-making and other regulations formulated as a result. The policies applicable to the San Fernando Wastewater Project are:

- National Environmental Policy



- National Wetlands Policy
- Draft National Protected Areas Policy
- Draft National Forest Policy

### 2.10.1 National Environmental Policy

The National Environmental Policy (NEP) was first formulated in 1998 and revised in 2005 by the EMA. The NEP was mandated as part of the Environmental Management Act and was compiled by the Directors of the EMA. The Policy has specific objectives which include:

- Prevention, reduction, recycling of pollution.
- Conservation of the vitality and diversity of the natural environment.
- Sustainable use of renewable resources and conservation of non-renewable resources.
- Changing attitudes and practices of citizens.
- Installation of Environmental Management Systems in all industries.
- Empowerment of stakeholders and communities to care for their environment.
- Promoting environmental sustainable development into country policies and programmes.

The NEP takes on specifics of sustainable development in Trinidad and Tobago and follows four broad principles.

The first principle is conservation of natural resources. This section as discussed in the NEP refers to ESA, ESS, coastal and marine areas, forests, wetlands, water and mineral resources and energy. These components of the natural environment have to be addressed according to the Policy to maintain biodiversity that may be impacted by development. Another pertinent initiative out of the policy is the “management of greenhouse gas (GHG) emissions and other forms of pollution resultant from energy conversion and end-use”. The mandate is for energy efficient technology to be employed to minimize pollution that will be considered in the design of the WWTP and equipment used for construction of the collection system.

Pollution, hazardous and toxic substances is the second principle addressed in the NEP. The types covered were air, noise, motor vehicle emissions, ozone depleting substances, greenhouse gases, wastes, hazardous waste, hazardous substances and spills, contaminated land, natural disasters and environmental emergencies. Most applicable to the San Fernando Wastewater Project is the stance that the NEP recommends on waste. The NEP instructs that Government will:

- Encourage the prevention and reduction of waste. This would be achieved specifically through clean technologies, disposal of dangerous substances in waste that will be recovered and development and marketing of products designed to minimally impact the environment.
- Encourage recycling, reuse or reclamation of waste.
- Ensure waste is recovered or disposed without hampering human health. The processes employed should not harm the environment through noise, odour or aesthetics.
- Establish and integrated waste disposal installation.

These initiatives are relevant to the treatment of wastewater and the disposal of the sludge and other wastes generated in the treatment process. The methods used follow the plans outlined in the NEP.



The third principle of the NEP was assessment of impacts, public information and environmental education. The environmental impact assessment as referred to in the NEP is significant for the San Fernando Wastewater Project since it is a rule that must be followed. This aspect of the Policy speaks to the designated activities requiring a CEC and the threshold of its activity. The proposed list in the NEP does not differ from the current List of Designated Activities, WPR 2001; however, the NEP refers to the issue of standards relevant to these activities. The general concept is for the development to follow a similar standard but not one that is less stringent than other countries.

The economic aspect of the NEP is the fourth principle in this document intended to promote and attain sustainable development. The Policy seeks to find financial instruments that will encourage environmental awareness. Pertinent to the San Fernando Wastewater Project, the Government proposes to revise legislation that would guarantee the polluter is liable for consequences of the polluting activity and ensure that responsibility is held from a financial standpoint.

### 2.10.2 National Wetlands Policy

The National Wetlands Policy was formulated as a result of the Convention on Wetlands that took place in Iran in 1993. The Convention details will be discussed in Section 2.11. The Forestry Division of the Ministry of Agriculture, Land and Marine Resources was designated as the focal point. A National Wetlands Committee was established in 1995, which was delegated to compile the National Wetlands Policy. The document was approved by Cabinet in 2001. **Appendix B.8** contains the preliminary list of wetland sites.

The rationale for a National Wetlands Policy is generally to conserve the wetlands of Trinidad and Tobago because of the many benefits from this environment. The definition of wetlands as adapted in this Policy has the same meaning as applied in the Convention on Wetlands, 1993. “Wetlands are areas of marsh, fen, peatland or water, whether natural or artificial, permanent or temporary, with water that is static or flowing, fresh or brackish or salt, including areas of marine water the depth of which at low tide does not exceed six metres”. The benefits of wetlands are:

- Employment.
- Exploitable resources including; timber, charcoal, tannins, plants and fish.
- The environment support marine resources and coral reef environments.
- Floodwater retention.
- Groundwater aquifer recharge.

Pertinent to the San Fernando Wastewater Project the National Wetlands Policy refers to the contribution of malfunctioning wastewater treatment plants to wetland degradation. The Policy briefly explains that the wastewater from these WWTPs is discharged into drainage channels that eventually flow into wetlands impacting negatively on the wetland habitat. Appended to the Policy document is a list of known wetland areas in Trinidad and Tobago; however, it does not include all. The wetlands at Marabella are included in the list as estuarine mangrove and are approximately 10,000 m<sup>2</sup> in area. There was also another swampy-marshy area identified in the fauna investigations of this project and will be discussed in Section 5.

There are a number of initiatives underlined in the National Wetlands Policy; however, the main one relating to the San Fernando project is through exemplifying practices supporting wetland conservation



in all government programmes. The method by which this will be achieved is through liaison between State agencies, the National Wetlands Committee and other stakeholders to prepare and implement a wetland management plan which will entail monitoring of the wetland. The Policy also mandates the implementation of an institutional and legislative framework of conservation of wetlands.

### 2.10.3 Draft National Protected Areas Policy

The draft version of the National Protected Areas Policy was completed in May 2009. The draft Policy was submitted for public consultation in April 2010. According to the National Protected Areas Policy a protected area is an area of land, body of freshwater or sea or combinations of these that are managed through legal or effective means to:

- Conserve biological diversity.
- Maintain ecosystem goods and services and facilitate sustainable land use.
- Provide recreational, educational, and cultural opportunities and facilitate the development of sustainable livelihoods.

There are currently some sites legally designated as Protected Areas, they include:

- Forest Reserves, based on the State Lands Act.
- Wildlife Sanctuaries, based on the Conservation of Wildlife Act.
- Prohibited Areas, based on the Forest Act.
- National Parks, based on the Chaguaramas Development Act.
- Protected Marine Areas, based on the Marine Areas (Preservation and Enhancement) Act.
- Environmentally Sensitive Areas based on the ESA Rules.
- Heritage Sites, based on the National Trust Act.

There are also some areas that are not Protected Areas by law but in practice. The San Fernando Hill is an example of a Protected Area designated in this regard within the San Fernando Wastewater Catchment. There is also an incentive by Ministry of Local Government to allocate National Heritage Parks across Trinidad and Tobago. To date none have been assigned in the project area but the Devil's Woodyard is an example of a proposed area; however this is not in the project boundaries.

The draft National Protected Areas Policy names WASA as a relevant agency that is mandated with the responsibility of designating protected areas. One of the functions of WASA is to prohibit or regulate activities undertaken in watersheds so that potential pollution can be prevented. In this regard WASA has the task as many other stakeholders do, to care for and oversee the Protected Areas of Trinidad and Tobago.

Overall, the goal of the National Protected Areas Policy is to:

- Designate and classify Protected Areas across Trinidad and Tobago.
- Institutionalise the sustainable management of Protected Areas.
- Develop methods of sustainable financing to oversee the implementation of the policy and associated legislation.
- Identify the human resource needs for attaining policy objectives.
- Resolve conflicts associated with other relevant policies.



- Develop legislation for Protected Areas.

#### 2.10.4 Draft National Forest Policy

The draft National Forest Policy was produced in June 2008 by the Ministry of Planning, Housing and the Environment. The first policy was created in 1942 when Trinidad and Tobago was still a British Colony. This policy was then revised in 1981 by the Conservator of Forests. In 1998, another draft Forest Policy was created and presented in Cabinet in 1999. The decision was made to present this new policy as a green paper; however, this has not been accomplished.

The draft Forest Policy completed in 2008 was a revision to the 1999 policy. The document has been submitted for public review and consultations were held from March to April 2010. The term forest includes natural and plantation forest and is defined as “ecosystems occurring on areas of land with existing or potential tree canopy of at least 50% covering a minimal land area of 0.4 ha”. The Forest policy categorises existing forested areas within Trinidad and Tobago into different regimes, these include:

- Production forests
  - Teak plantations
  - Pine plantations
  - Natural forests
- Protection forests
  - Areas above 90 m contour
  - Proposed national parks
  - Prohibited areas
  - Certain wildlife sanctuaries
  - Nature reserves
  - Dams
  - Wild belts within Forest Reserves
  - Some private forested areas

Despite the fact that the existing San Fernando WWTP is not situated on a Forest Reserve the Forest Policy names certain activities that may cause forest degradation. Relevant to the San Fernando Wastewater Project forest degradation is caused by “increasing physical development of land for industrial and commercial activities, including roads, pipelines, utility right-of ways (ROW), oil and gas infrastructure, tourism and public infrastructure”.

The main objective of the Forest Policy is to act as a guideline to sustainable management of forest resources. The policy outlines a number of initiatives to bring about change in the way forested areas are managed and conserved. Some of these initiatives are more applicable to the San Fernando Wastewater Project and can be implemented within the main framework of the project. One initiative relevant to the San Fernando Wastewater Project is maintenance and enhancement of the natural productivity of forest ecosystems and ecological processes. The methods by which this will be implemented, according to the Forest Policy are as follows:



- Ensure lands best suited for provision of forest products remain under forest cover.
- Identify, protect and manage areas providing key ecological services.
- Manage forests to ensure maintenance of evolutionary and ecological processes.
- Promote reforestation and rehabilitation of forests.
- Utilize forest and component biodiversity as an early warning system for pollution effects.

## 2.11 Multilateral Agreements/Conventions

There are a number of treaties and conventions that Trinidad and Tobago have ratified that relate to environmental protection. The list is presented in Table 2-8 and includes all treaties in various environmental fields that Trinidad and Tobago are signatory to. The most official form of sanctioning these agreements is through ratification and for most of these treaties Trinidad and Tobago has done so.

**Table 2-8 List of Multinational Agreements, Treaties and Conventions Ratified by Trinidad and Tobago**

Treaty/Convention	Year Entered Into Force	Year Ratified by Trinidad & Tobago
Convention on Nature Protection and Wildlife Preservation in the Western Hemisphere	1942	1942
International Plant Protection Convention	1952	1970 (adherence)
Geneva Convention on the High Seas	1962	1962
Treaty Banning Weapon Tests in the Atmosphere, in Outer Space and Under Water	1963	1963
Convention on the Territorial Sea and the Contiguous Zone	1964	1964
Geneva Convention on the Continental Shelf	1964	1968
Convention on Fishing and Conservation of the Living Resources of the High Seas	1966	1966
Convention Concerning the Protection of the World Cultural and Natural Heritage	1972	2005
Convention on International Trade in Endangered Species of Wild Fauna and Flora (CITES)	1975	1984
Convention on Wetlands of International Importance (RAMSAR Convention)	1975	1993
Vienna Convention on Civil Liability for Nuclear Damage	1977	1977 (accession)
UN Convention on the Law of the Sea	1982	1994
Convention for the Protection and Development of the Marine Environment of the Wider Caribbean and its Protocols concerning co-operation in combating oil spills in the wide Caribbean Region	1986	1986
Vienna Convention Protection of the Ozone Layer	1988	1989
Lome IV Convention	1989	1989
Montreal Protocol on Substances that Deplete the Ozone Layer	1989	1989

**Table 2-8 List of Multinational Agreements, Treaties and Conventions Ratified by Trinidad and Tobago (continued)**

Treaty/Convention	Year Entered Into Force	Year Ratified by Trinidad & Tobago
Protocol Concerning Pollution from Land-based Sources and Activities	1999	1999
Cartagena Protocol on Biosafety	2000	2000
Stockholm Convention on Persistent Organic Pollutants	2001	2002
Rotterdam Convention on the Prior Informed Consent Procedure for Certain Hazardous Chemicals and Pesticides in International Trade	2004	2009
Convention on the Conservation of Migratory Species of Wild Animals	2010	Not yet ratified
Protocol Concerning Specially Protected Areas and Wildlife (SPA Protocol)	1990	1990
Basel Convention on the Control of Transboundary Movement of Hazardous Wastes and their disposal	1992	1994
UN Framework Convention on Climate Change	1992	1994
UN Framework Convention on the Conservation of Biological Diversity	1993	1996
Convention to Combat Desertification	1994	2000
International Tropical Timber Agreement	1997	1997
Kyoto Protocol	1997	1999
Montreal Protocol on Substances that Deplete the Ozone Layer (Amended London, 1990; Copenhagen, 1992; Vienna, 1995; Montreal, 1997; Beijing, 1999)	-	-

## 2.12 Approval Agencies

The environmental regulatory and legislative framework of Trinidad and Tobago is managed by different organizations with each agency having a separate portfolio from the other. These agencies include:

- Environmental Commission
- Town and Country Planning Division
- Municipal Corporations
- Ministry of Works and Transport

The EMA is another approving agency that is responsible for ensuring sustainable development is attained. The functions of the EMA were discussed in Section 2.2.1.



### 2.12.1 The Environmental Commission

The Environmental Commission is the judicial body that exercises the environmental regulations that exist in Trinidad and Tobago. The Commission is a superior court made up of a Chairman and Deputy Chairman who must be attorneys-at-law, and other technical staff. The body was formulated out of the Environmental Management Act and the main function is to adjudicate applications, appeals and complaints. Specific responsibilities of the Commission are:

- Hearings and decision-making
- Alternate dispute resolutions
- Staff processing of hearings
- Public relations
- Public access to information

The Environmental Commission is mandated to hear appeals made by companies when applications such as that of a CEC are denied. The jurisdiction of the court is mainly concerning actions made by the EMA.

### 2.12.2 Town and Country Planning Division

The Town and Country Planning Division (TCPD) is a department within the Ministry of Planning, Housing and the Environment. It was established as part of the Town and Country Planning Act. The mandate of the TCPD was to administer the use and development of all land in Trinidad and Tobago through development planning and development control. The specific functions are:

- Establish a national physical development planning framework for regional and local area plans that would be utilised for decision-making purposes and to guide development accordingly.
- Review applications for planning permission.
- Review applications for display of advertisements.
- Enforce planning control.
- Assist in the preparation and review of planning legislation.
- Compile a database of land use planning data in Trinidad and Tobago.
- Compile a register of all planning applications.

The TCPD is responsible for granting planning permission for proposed developments on both privately and state-owned land. There are two forms of planning permission; outline and full. Outline planning approval is to be pursued by all developments. The purpose of outline planning approval is to ensure consistency between the type of development and the land use policy for the proposed site.

Full planning approval is sought by specific types of activities, this includes:

- Building operations (erection and renovation).
- Land or building use change.
- Retention of an existing building.
- Land subdivision.
- Cutting, clearing, grading or filling activities.
- Road and drain construction.





The San Fernando Wastewater Project includes some of these activities and would therefore require both outline and full planning approval before construction commences. The TCPD monitors proposed development in Trinidad and Tobago by reviewing CEC applications prior to submission by the EMA. The procedure when applying for a CEC is to submit the completed application to the TCPD regional office closest to the location of the development. The TCPD then peruses the application to determine the type of development, location and what type of, if any, planning permission is required.

### 2.12.3 Municipal Corporations

Municipal Corporations of Trinidad and Tobago were established under the Municipal Corporations Act, 1992 and falls under the Ministry of Local Government. The corporations are operated by an elected Council comprising a Mayor who heads the Council and a Chairman who leads the corporation. The general role of the municipal corporations is to make policies and bye-laws. Different villages and communities comprise specific corporations and the corporation is responsible for maintaining the aesthetics and infrastructure within the area. The San Fernando Wastewater Catchment Area covers three municipal corporations. They are:

- San Fernando City Corporation, which includes the following collection system subcatchments:
  - Cocoyea
  - Tarouba
  - St. Joseph Village
  - Les Efforts
  - Ciperó
  - La Romain
  - Gulf View
  - Marabella
  - Vistabella
  - Mon Repos
  - Navet
  - Pleasantville
  - Spring Vale
  - Paradise
- Princes Town Regional Corporation, which includes the following collection system subcatchment:
  - Corinth
- Penal/Debe Regional Corporation, which includes the following collection system subcatchments:
  - Palmiste
  - Union Hall

The city and Regional Corporations are responsible for different aspects of infrastructure and public health within the various communities. These responsibilities are:

- Garbage collection.



- Cesspit and septic tank emptying.
- Construction and maintenance of roads other than main roads and highways.
- Construction and maintenance of drains, bridges, pavements and street signs.
- Street lighting.
- Maintenance of water courses.
- Maintenance of cemeteries and cremation sites.
- Maintenance of recreational areas.
- Maintenance of markets.
- Inspection of buildings and development sites.
- Approval of building and housing plans.
- Cleaning public spaces.
- Vector control.
- Disaster management.
- Provision of truck-borne water in dry seasons.
- Collection of land and building taxes.
- Establishment and enforcement of by-laws.

With these functions, the municipal corporations are an approving agency. The development plans would have to be reviewed and approved for the San Fernando Wastewater Project and the relevant corporations have been made aware of the project. The Water and Sewerage Act also states that during installation of sewer or water mains the municipal corporation must supervise and ensure that the road is restored according to an acceptable standard.

#### 2.12.4 Ministry of Works and Transport

The Ministry of Works and Transport (MOWT) is responsible for all major roads, secondary roads and highways in Trinidad and Tobago. MOWT main functions are construction and maintenance of the major roads and major waterways. The proposed sewer layout will be in road right of ways, with many road and waterway crossings. The details of the design are in Section 3 of this report. Liaison has been made with both the Highways Division and Drainage Division of the MOWT in order to introduce the project and the development plans respective to major roads and water courses in San Fernando and environs.



## 3. Project Description

### 3.1 Objective

The objective of this section is to outline, and where possible, provide detailed information on the proposed project in accordance with the EIA TOR for CEC 1597/2006. The project description addresses details of the collection and treatment of the wastewater, labour requirements, activities associated with pre-construction (i.e. enabling works), and construction phase activities. The project description also addresses those activities that will occur during the operational life of the treatment plant and collection system. Non-routine (i.e. accidental) events are discussed, followed by the decommissioning stage.

The design of the San Fernando Wastewater Project has the following objectives:

- Identify the most effective and optimal regional arrangement of the wastewater systems within the city of San Fernando and its environs from a technical, operational, and cost standpoint.
- Prepare detailed designs and tender documents for the rehabilitation of the existing wastewater collection systems within the city of San Fernando and its environs, and for the construction of new wastewater collection systems in areas that are presently not serviced.
- Prepare detailed designs, and tender documents for the construction of one new WWTP.
- Design the wastewater treatment plant to ensure the effluent complies with the Draft Water Pollution Rules, 2001 (as amended).
- Design the collection system and treatment facility to serve communities up to the design horizon of 2035, at minimum investment and operations costs.

### 3.2 Project Background

The city of San Fernando is the second largest urban centre in Trinidad. It is the commercial hub of south Trinidad and has been steadily expanding with the growth of the oil and gas sector and downstream activities in south Trinidad. The city of San Fernando's current population is approximately 55,400. The city is serviced by a wastewater collection, treatment and disposal system built in the 1960's and owned and operated by WASA. This collection system has approximately 72 km of piping, and services approximately 25,000 of the city's population. The wastewater treatment plant was originally designed to treat 20 ML/d. A septage receiving station was constructed at the San Fernando plant in the 1980's.

The wastewater system has functioned adequately for a number of years but has passed its useful design life and is in need of major rehabilitation and expansion to meet the current and future needs of the city and surrounding areas. Field studies have revealed that sections of the existing collection system are in need of replacement as some visible sections of trunk sewer have broken open and fallen into drains and rivers, allowing untreated wastewater into the waterways.



The areas outside of the existing San Fernando collection system have experienced significant development over the past several years. The estimated population of the surrounding areas outside the city limits is approximately 47,600. Numerous private and government housing, commercial and institutional developments have emerged along with separate wastewater collection systems, pump stations and packaged wastewater treatment plants (WWTPs), most not maintained by WASA. These areas include Harmony Hall, Tarouba, Pleasantville, Palmiste, and Gulf View. In addition, approximately 70% of developed areas surrounding San Fernando are not sewered, and are serviced by on-lot systems including septic tanks, soak-aways, and pit latrines. The conditions of these existing systems vary; however, the majority of the systems are not functioning or only partially functioning, resulting in untreated or partially treated wastewater entering waterways.

WASA intends to improve the wastewater sector in the city of San Fernando and environs by expanding the sewered service area and improving the level of wastewater treatment for existing and new customers in the rapidly developing area. The end result of the project will be an integrated and centralized wastewater system that provides a cost-effective and sustainable wastewater collection and treatment for the city of San Fernando and environs. The main benefits of the project include:

- Reduction in public health risk associated with untreated wastewater discharges into drains, rivers and other water courses.
- Improvement of water quality in the Guaracara, Marabella, Vistabella and Cipero Rivers that currently receive wastewater discharges.
- Overall improvement to the surrounding environment through the proper collection, treatment and disposal of wastewater that is presently adversely affecting the environment.
- Potential for production of up to 45 ML/d of reclaimed water that is suitable for irrigation and other non-potable uses in the area.
- Overall improvement in the quality of life for the citizens of San Fernando and environs.

### 3.3 Project Boundaries

The project boundaries are roughly defined by the Guaracara River in the North, Solomon Hochoy Highway including Ste. Madeline in the East, housing development within the M2 Ring Road in the South, and Gulf of Paria in the West. The boundaries are indicated by the dashed yellow line in Figure 3-1.

Major roads located within the project boundary include the Solomon Hochoy Highway, San Fernando By-Pass, Lady Hailes Road, South Trunk Road, Naparima Mayaro Road, and Tarouba Link Road.

Rivers located within the project boundary include the Guaracara, Marabella, Vistabella, and Cipero. Ally's creek and other un-named drains channel water in the wet season.

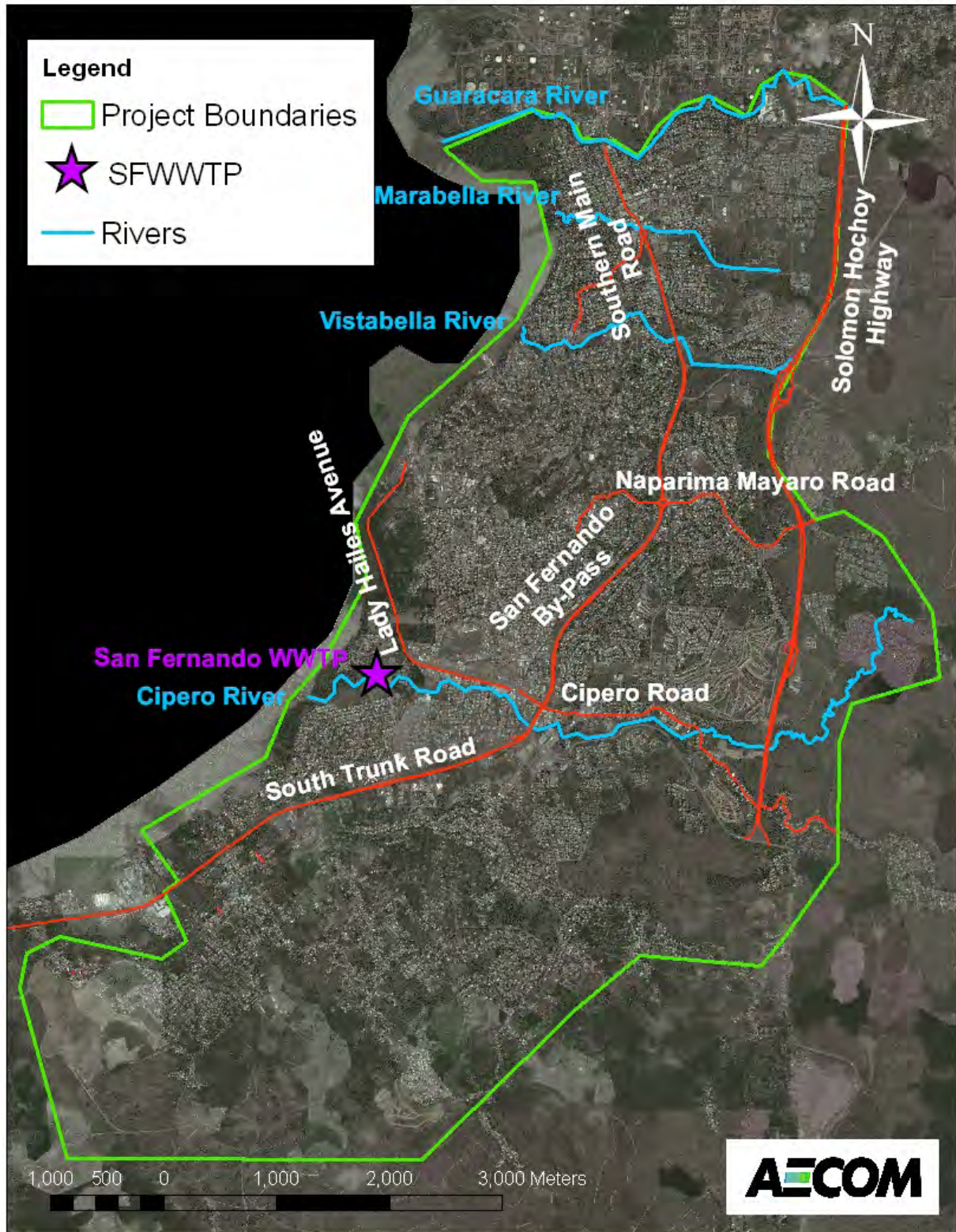


Figure 3-1 Project Boundaries, Roads and Rivers



### 3.4 Land Use and Population

Land use within the catchment is mainly residential, along with commercial, industrial and institutional uses. Commercial land use is primarily along main roads in the catchment, such as the Southern Main Road, San Fernando By-Pass Road, and the Southern Trunk Road. Industrial land uses are primarily concentrated within industrial estates areas such as the eTeck Harmony Hall Industrial Estate in Marabella, and along the north bank of the Ciperu River. Institutional land uses include schools, recreation centres, and hospitals are found throughout the catchment. These include the San Fernando Technical College and San Fernando General Hospital.

A land use category map was developed, and the results illustrate that over 60% of the project area is currently developed by human activities (Figure 3-2).

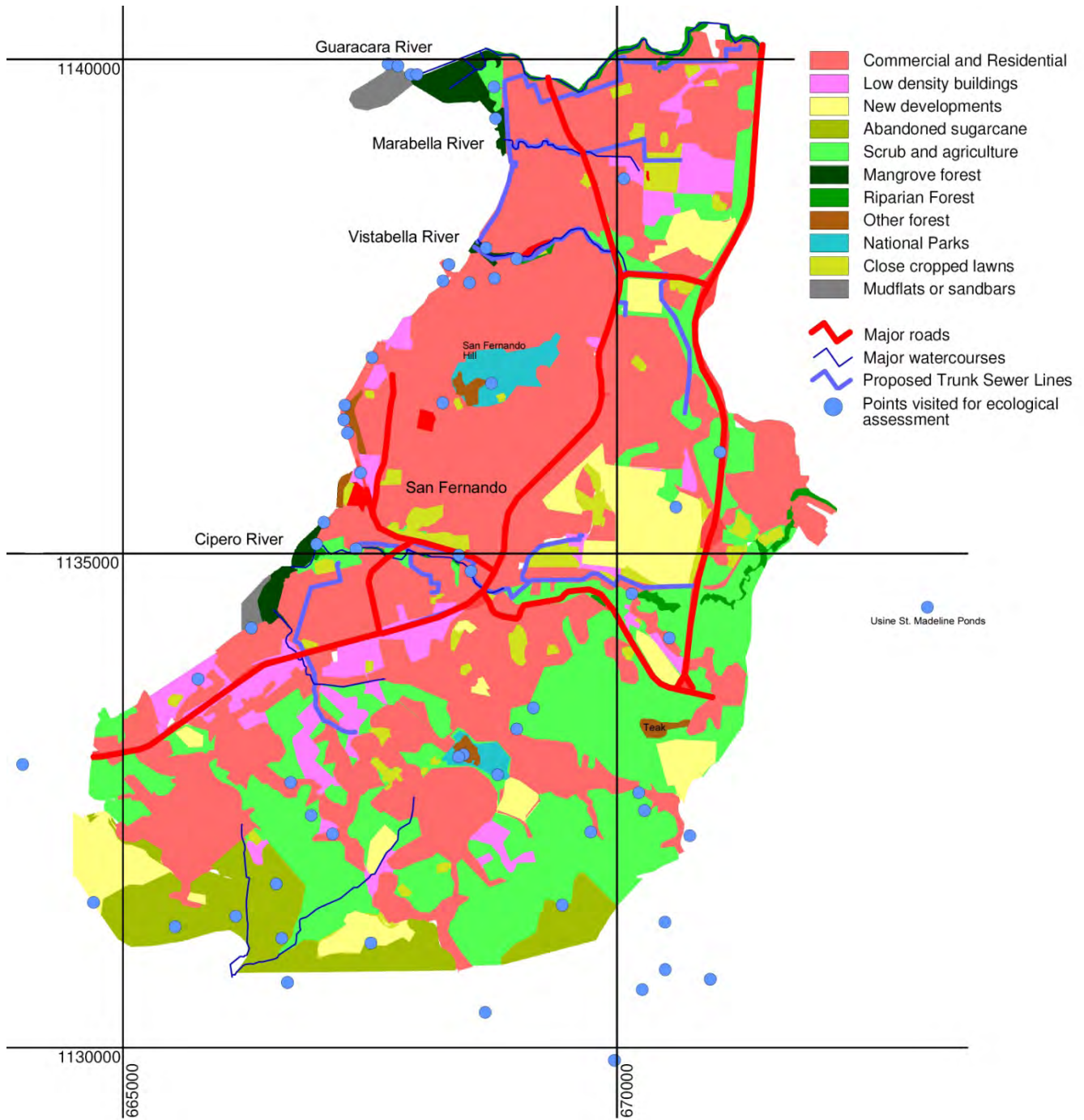


Figure 3-2 Map of San Fernando and Environs Showing Land Use (White, 2009)



The projected population was determined through satellite imagery housing counts and forecasting undeveloped land (i.e., abandoned sugarcane, scrub and agriculture) to the project design life of 2035. These numbers were verified with development plans from the San Fernando Regional Corporation, and other sources.

**Table 3-1 Summary of Population Projections**

Population Projection	2000	2009	2035
2000 Census	89,200	-	-
Satellite Housing Counts with Future Developments	-	90,200	111,600

### 3.5 Existing Sewered Areas

The San Fernando City subcatchment is approximately 7 km<sup>2</sup> and is served by a centralized wastewater collection, treatment and disposal system owned and operated by WASA. The largest sewered areas outside of the San Fernando City subcatchment are the Palmiste Development (1.4 km<sup>2</sup>), Union Hall Development (0.8 km<sup>2</sup>) and Gulf View Development (0.7 km<sup>2</sup>). Smaller systems exist throughout the project area. There are 9 WWTPs and 13 lift stations (LS) within the catchment boundaries. Of the 9 WWTPs, 5 are operating; however, inspections reveal that effluent quality is typically poor. Effluent from these WWTPs is discharged into the nearby watercourses. Of the 13 lift stations, 4 are operating. Of the remaining 9, 2 are under construction, and 7 are in a state of disrepair and not operational. Details are shown in Table 3-2. These poorly functioning wastewater systems result in improperly treated wastewater being discharged into the environment.

**Table 3-2 Existing Lift Stations and WWTPs in San Fernando Area**

Facility	Operational Status	Owner
<b>Lift Stations</b>		
Corinth HDC LS	Newly constructed but not commissioned	Private
Gulf View Development LS	Appears to be operational	Private
Harmony Hall LS	Operational	WASA
Kelvin Avenue LS	Not operational. Construction never completed	Private
Palmiste Boulevard LS	Constructed but not operational	Private
Pleasantville LS	Operational	WASA
Pollonais Crescent #1 LS	Constructed but not operational	Private
Pollonais Crescent #2 LS	Constructed but not operational	Private
Retrench HDC (Hillcrest Gardens) LS	Under construction	Private
Tarouba North LS	Constructed but does not appear to operational	Private



**Table 3-2 Existing Lift Stations and WWTPs in San Fernando Area (continued)**

Facility	Operational Status	Owner
Tarouba Heights LS	Operational	Private
Union Hall #1 LS	Not operational	WASA
Union Hall #2 LS	Not operational	WASA
<b>WWTPs</b>		
San Fernando WWTP	Operating	WASA
Gulf View Development WWTP	Semi-operational	Private
Harmony Hall (eTeck) WWTP	Operating	Under WASA Contract
Marabella Secondary School WWTP	Operating	Private
Palmiste WWTP	Not functional	Private
San Fernando Technical Institute WWTP	Operating	Private
Sunkist WWTP	Not functional	Private
Westpark WWTP	Not functional	Private

Descriptions of these larger systems are presented below, while the locations of all existing sewered areas, WWTPs and lift stations are shown on Figure 3-3.

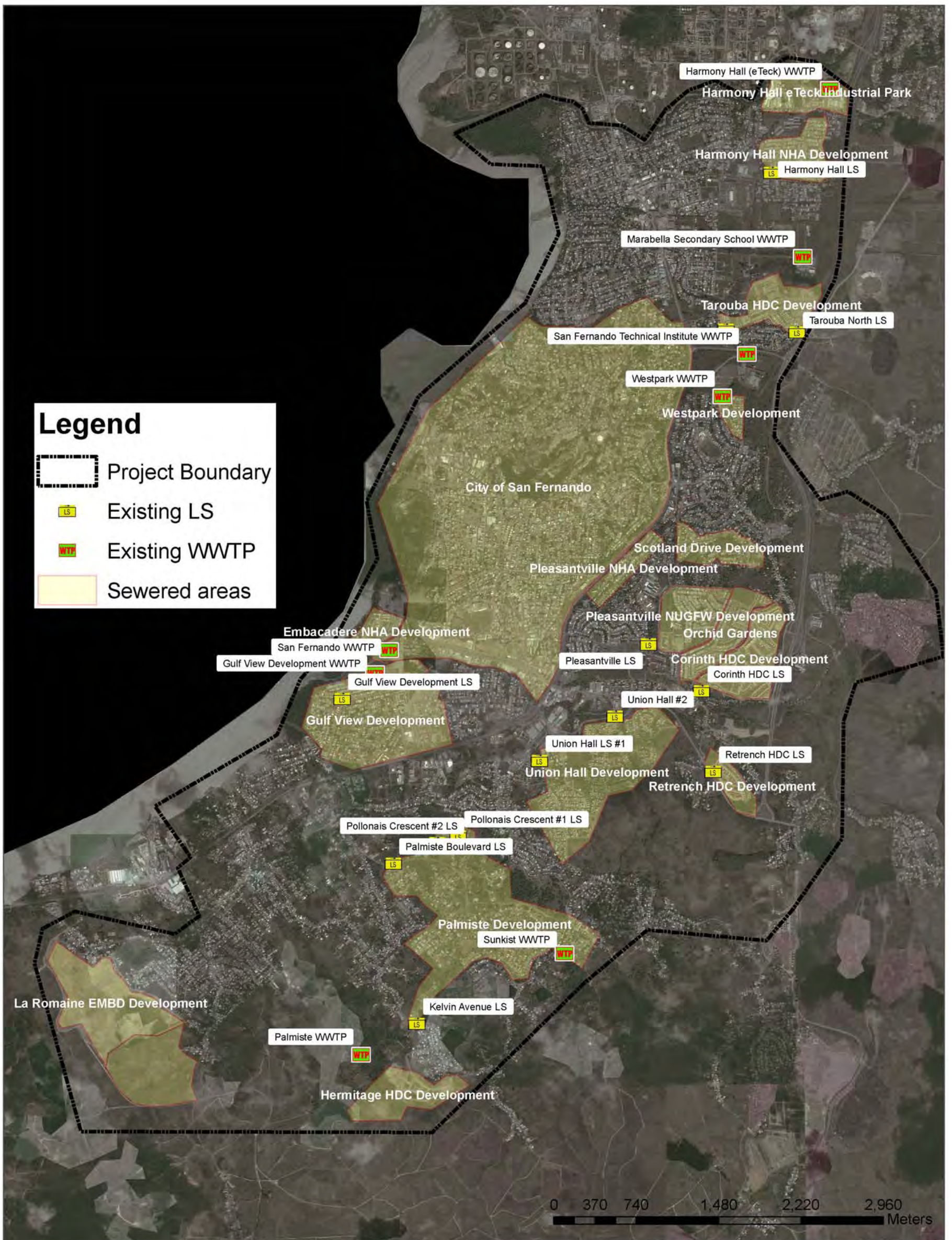


Figure 3-3 Existing Lift Stations and WWTPs, with Current Sewered Areas Displayed



### 3.5.1 San Fernando City Sewerage System

The San Fernando City sewerage system was constructed in the 1960's (Lockjoint Project). The population equivalent (pe) within the existing system is approximately 23,100. Wastewater collected from the area drains into the San Fernando WWTP.

Sections of the trunk sewer that run along the seawall between the San Fernando Yacht Club and King's Wharf are deteriorated and allow infiltration of seawater into the sewer system at high tide (Figure 3-4).



**Figure 3-4 Section of Trunk Sewer Along the Sea Wall Showing Possible Points of Inflow at Pipe Joints**

There are also sections of collapsed or segmented trunk sewer pipes along the Vistabella River (Figure 3-5). These defects are likely caused by soil erosion from the Vistabella River.



**Figure 3-5 Section of Trunk Sewer along Vistabella River Showing Open Joint**



### **3.5.2 Palmiste Development Sewerage System**

Most of the wastewater from the Palmiste Development is collected by gravity sewer systems for treatment at the Palmiste WWTP. In four areas lift stations pump wastewater from low lying areas to gravity pipelines. These lift stations are the Palmiste Boulevard LS (servicing mostly the north of the Palmiste Development), Pollonais LS #1 & #2 (servicing the Pollonais Crescent area) and the Kelvin Avenue LS (pumping wastewater from the Palmiste Development main gravity pipeline to the Palmiste WWTP).

### **3.5.3 Union Hall Development Sewerage System**

The Union Hall Development is sewered and serviced by two lift stations. Union Hall LS #2 pumps wastewater from gravity sewers mainly in the eastern side of the development to Union Hall LS #1. Union Hall LS #1 collects wastewater on the western side of the development and pumps into the existing San Fernando collection system. Union Hall LS #2 is currently not in operation.

### **3.5.4 Gulf View Development Sewerage System**

The Gulf View Development is serviced by the Gulf View Development LS and the Gulf View Development WWTP. The effluent is discharged into the Ciperó River.

## **3.6 Present Wastewater Volume and Strength**

AECOM conducted a wastewater sampling programme at the existing San Fernando WWTP during August 2009. The results of the wastewater analyses are presented in Table 3-3. The samples were 24-hour composite samples taken from the inlet pumping station, upstream of any septage addition.



**Table 3-3 Raw Wastewater Concentrations at the Existing San Fernando WWTP (2009)**

Date	Flow <sup>1</sup> (ML/d)	COD (mg/L)	TSS (mg/L)	TKN (mg/L)	NH <sub>3</sub> (mg/L)	TP (mg/L)
04-Aug	9.1	660	510	29	19.0	2.56
05-Aug	8.6	336	220	20	18.1	1.99
11-Aug	4.6	472	200	23	20.3	5.44
13-Aug	9.0	588	370	27	26.5	5.57
14-Aug	10.8	634	312	22	17.9	6.90
17-Aug	5.5	344	310	18	11.8	5.02
18-Aug	4.2	606	275	31	23.5	2.28
19-Aug	10.7	501	240	25	30.0	3.67
20-Aug	6.6	456	280	19	15.7	5.54
21-Aug	6.3	358	340	17	17.4	4.87
24-Aug	6.2	280	174	10	8.4	4.48
Minimum	4.2	280	174	10	8.4	1.21
Maximum	10.8	660	510	31	30	6.90
Arithmetic Average	7.4	476	294	21.9	19.0	4.39
Flow Weighted Average	-	490	302	22.2	19.7	4.43

**Notes:**

- Flow readings were determined from real-time flow data that was recorded throughout the day, with an M-series EMCO UniMAG electromagnetic flow meter.

Based on the sampling results in Table 3-3 the raw wastewater entering the WWTP is relatively strong with respect to COD and TSS, but low to medium strength in terms of total Kjeldahl nitrogen (TKN), ammonia and phosphorus.

The existing San Fernando WWTP receives significant quantities of septage, from a number of sources, as summarized in Table 3-4.

**Table 3-4 Sources of Septage for the Existing San Fernando WWTP**

Sources of Septage
Point Fortin Borough Corporation
Penal/Debe Regional Corporation
Siparia Regional Corporation
Princes Town Regional Corporation
Couva/ Tabaquite/ Talparo Regional Corporation
Shade General Contractors Ltd.
Waste Cleaners & Disposal Co. Ltd.
San Fernando City Corporation
Emergency Septic
B.K. Holdings



To estimate the future quantities of septage that will be received by the San Fernando WWTP, it was assumed that the regional corporations would continue to direct their hauled waste to San Fernando, but private contractors would deliver 50% of their current loads; due to the reduced amount of waste available once the new collection system is installed.

The septage data for 2008 has been analysed and is presented in Table 3-5.

**Table 3-5 Septage Volumes in 2008**

Month	Total Septage Volume (m <sup>3</sup> ) <sup>1</sup>	Estimated Future Septage Volume (m <sup>3</sup> ) <sup>2</sup>
January	1,186	930
February	1,346	1,117
March	1,457	1,183
April	1,703	1,435
May	1,487	1,198
June	1,718	1,362
July	1,911	1,519
August	1,581	1,263
September	1,639	1,384
October	1,753	1,492
November	1,450	1,223
December	440	382
<b>Average</b>	<b>1,472</b>	<b>1,207</b>
<b>Maximum</b>	<b>1,911</b>	<b>1,519</b>

**Notes**

1. Actual volumes for 2008
2. Volumes for 2008 minus 50% of the volume from the private haulers

WASA does not currently monitor the quality of the septage. To evaluate the pollutant loads, typical septage concentrations have been used, as shown in Table 3-6.

**Table 3-6 Typical Septage Concentrations**

Parameter	Suggested Design Value (mg/L) <sup>1</sup>
BOD <sub>5</sub>	7,000
COD	15,000
TSS	15,000
TKN	700
NH <sub>3</sub> -N	150
TP	250

**Notes**

1. US EPA Handbook: Septage Treatment and Disposal (October 1984)

AECOM also collected samples from the Harmony Hall WWTP and lift station in September and October, 2009. The results are provided in Table 3-7.

**Table 3-7 Raw Wastewater Concentrations at Harmony Hall (2009)**

Date	Sample Type	Sample Location	COD (mg/L)	TSS (mg/L)	NH <sub>3</sub> (mg/L)	TP
18-Sept	Composite	WWTP Influent	280	114	26.4	7.74
25-Sept	Grab	WWTP Influent	1,020	500	40.0	-
01-Oct	Grab	WWTP Influent	227	88	13.7	7.47
01-Oct	Grab	Lift Station	397	77	45.9	7.69
02-Oct	Grab	Lift Station	612	219	36.0	9.28
05-Oct	Grab	Lift Station	452	56	50.4	8.23

The composite sample from Harmony Hall is indicative of a weak to medium strength wastewater of domestic origin, although the ammonia concentration is relatively high, and the phosphorus is high. The grab samples indicate that there is likely an industrial discharge occurring, with high COD, ammonia and phosphorus concentrations and a low TSS concentration. This industrial discharge might not be occurring every day, and hence might not have been present on the day of the composite sample. The grab samples were all taken during the period 09:00 am to 10:00 am, and therefore may be measuring an intermittent industrial discharge. It would not be prudent to design a wastewater treatment plant for high strength industrial wastewater; the preferred approach is to control industrial effluents at their source. WASA will need to investigate industrial discharges in the area, and implement stricter industrial effluent control measures.



### 3.7 Design Effluent Flows and Criteria

#### 3.7.1 Design Flows

The average dry weather flow (ADWF) consists of four components:

- Base domestic flow.
- Base commercial component.
- Base industrial component.
- Base infiltration and inflow (I&I).

Peaking factors are applied to the ADWF to estimate the peak dry weather flow (PDWF) and peak wet weather flow (PWWF). PDWF is used for determining the required capacity of the secondary treatment process within the WWTP. Flows in excess of the PDWF will be stored on site until secondary treatment capacity is available. PWWF is used for sizing sewer pipes and lift stations and the overall hydraulic capacity of the WWTP.

Table 3-8 outlines the design flows that will be used for the San Fernando Project.

Design loads have been calculated from information on the loads entering the current San Fernando and Harmony Hall WWTPs, as well as typical design values. (Table 3-9)

**Table 3-8 Summary of Project Design Flows**

Design Parameter	Units	Value
Design Year	-	2035
Equivalent Population	pe	111,600
Unit ADWF	Lpcd	400
Design ADWF	ML/d	45.0
Dry Weather Peaking Factor (PDWF / ADWF)	-	2.0
PDWF	ML/d	90
Peaking Factor (PWWF / ADWF)	-	3.5
PWWF – (WWTP & Collection System)	ML/d	158

**Table 3-9 Average Design Loads for San Fernando WWTP**

Parameter	Unit	Average Value
BOD	mg/L	176
COD	mg/L	386
TSS	mg/L	248
TKN	mg/L	35
TP	mg/L	4.8





### 3.7.2 Design Effluent Criteria

The design effluent criteria are based on treating the wastewater to meet regulations governing reclaimed water as defined in North America. This will provide effluent water that can be used for agricultural and industrial uses instead of discharging this valuable resource to the Ciperó River. Until such time as users of the reclaimed water are identified, the treated effluent from the WWTP will be discharged to the Ciperó River.

Water reuse practices have been adopted in many countries because of increasing demand for water and decreasing supply of traditional sources of water. As part of the San Fernando WWTP design, the option of effluent reuse for non-potable applications has been adopted. Trinidad and Tobago currently do not have standards for water reuse. In the U.S., water reuse and reclamation standards are the responsibility of state agencies. The U.S. Environmental Protection Agency (EPA) published the document entitled “Guidelines for Water Reuse” (2004) to summarize the state guidelines and supporting information.

Treated wastewater may be reused for many applications, such as industrial process and cooling water, agricultural, urban, environmental or recreational uses. The U.S. guidelines are specific to the water application. For the San Fernando WWTP, the agricultural reuse (food crop irrigation) application was selected for comparison because of the proximity of the Picton Estates Mega Farm, a likely destination for the treated effluent. The guidelines are state-specific. Florida was selected for comparison for its similar climate and agricultural production to Trinidad. The guidelines for Agricultural Reuse for Food Crops for Florida are summarized below:

- Treatment: Secondary treatment, filtration and high level disinfection to meet the required Faecal Coliform concentrations.
- Carbonaceous Biochemical Oxygen Demand (CBOD<sub>5</sub>) : <20 mg/L (annual average).
- TSS: <5 mg/L (single sample).
- pH: 6 to 8.5.
- Faecal Coliform: 75% of samples below detection (30 day average) and maximum 25 CFU/100 mL (single sample).

In addition, Florida has the following monitoring requirements for reclaimed water:

- Continuous on-line monitoring of turbidity (as an indicator of treatment plant performance) and chlorine residual.
- Minimum schedule for sampling and testing flow, pH, dissolved oxygen, chlorine residual, TSS, CBOD, nutrients and Faecal Coliforms.
- Monitoring for Giardia and Cryptosporidium once every two years for reclaimed water facilities greater than 3.8 ML/d.

In general, the U.S. EPA Guidelines for Water Reuse for Food Crops (Florida) are more conservative than the EMA Water Pollution Rules.

The reuse standards in Table 3-10 have been adopted as design effluent criteria. These standards exceed those stipulated in the EMA Water Pollution Rules 2001 (as amended) for Inland Surface Water Discharges.



**Table 3-10 San Fernando WWTP Effluent Criteria**

Parameter	EMA Water Pollution Rules 2001 (as amended) for Inland Surface Water Discharge	Design Effluent Criteria
BOD <sub>5</sub> (mg/L)	30	< 20 mg/L (CBOD) <sup>2,4,5</sup>
TSS (mg/L)	50	< 5 <sup>2,4,5</sup>
Dissolved Oxygen (mg/L)	> 4	> 4 <sup>1,3,4,5</sup>
Temperature °C	< 35	< 35 <sup>1,4,5</sup>
Ammonia-Nitrogen (mg/L)	10	< 10 <sup>1,4,5</sup>
Total Nitrogen (mg/L)	-	< 15 <sup>3,4,5</sup>
Total Phosphorus (mg/L)	< 5	< 5 <sup>1,3,4,5</sup>
Faecal Coliform (CFU/100ml)	400	Max: 25/100 mL and 75% samples below detection <sup>2,7,6</sup>
pH	6-9	6 to 8.5 <sup>2,4,5</sup>
Total Residual Chlorine (mg/L)	1	<1 <sup>4,7,5</sup>

**Sources:**

1. Environmental Management Agency (EMA) Water Pollution Rules (Amended 2006), Second Schedule: Permissible Levels of Water Pollutants for Inland Surface Water.
2. U.S. Environmental Protection Agency (EPA) Guidelines for Water Reuse (2004). Table 4-5 Agricultural Reuse – Food Crops for Florida.
3. Water and Sewerage Authority (WASA) Bidding Document for Provision of Consultancy Services for the Integration, Expansion, Upgrade and Refurbishment of the Wastewater Systems in the City of San Fernando and Environs. (April 2007).
4. US Environmental Protection Agency (EPA) Guidelines for Water Reuse (2004). Table 4-13 Suggested Guidelines.

**Notes:**

5. Compliance basis is arithmetic average of daily values for a calendar month.
6. Compliance basis is geometric mean of daily values for a calendar month.
7. The Faecal Coliform and total residual chlorine concentrations for water reuse are included for WASA's future reference, for when it implements water reuse.

### 3.8 Overall Scope of Works

The San Fernando Wastewater project comprises one integrated collection system and one WWTP. The collection system design includes installation of new trunk sewers for conveying wastewater to the new WWTP, new local sewers to capture flow from properties that do not currently have sewer service and combining new and existing sewers into a single integrated collection system. The new WWTP will replace the existing San Fernando WWTP, Harmony Hall WWTP, and several smaller plants previously installed by developers. The new WWTP will be located on the site of the existing San Fernando WWTP, at the western end of Riverside Drive, north of the Ciperó River (Figure 3-6). Land west of the site, that does not currently have equipment constructed on it, will also be utilized.

With the implementation of the project, WASA will become the sole responsible Authority for wastewater treatment and disposal in the Catchment, and will be able to effectively monitor, regulate and control effluent discharged to the environment.



**Figure 3-6 Location of Existing San Fernando WWTP**

### 3.9 Wastewater Treatment Plant Scope of Works

The new San Fernando WWTP will replace all existing plants within the project boundaries (See Section 3.5), and will be located on the site of the existing San Fernando WWTP. Entrance to the plant is currently from Riverside Drive; however, plans are being made to provide an alternate entrance from Gulf View Industrial Park Road.

Construction sequencing will ensure that treatment of the incoming wastewater continues throughout construction.

The plant will be sized to treat the design year 2035 ADWF of 45 ML/d and PDWF of 90 ML/d through secondary and tertiary treatment. The influent pump station and screenings and grit removal

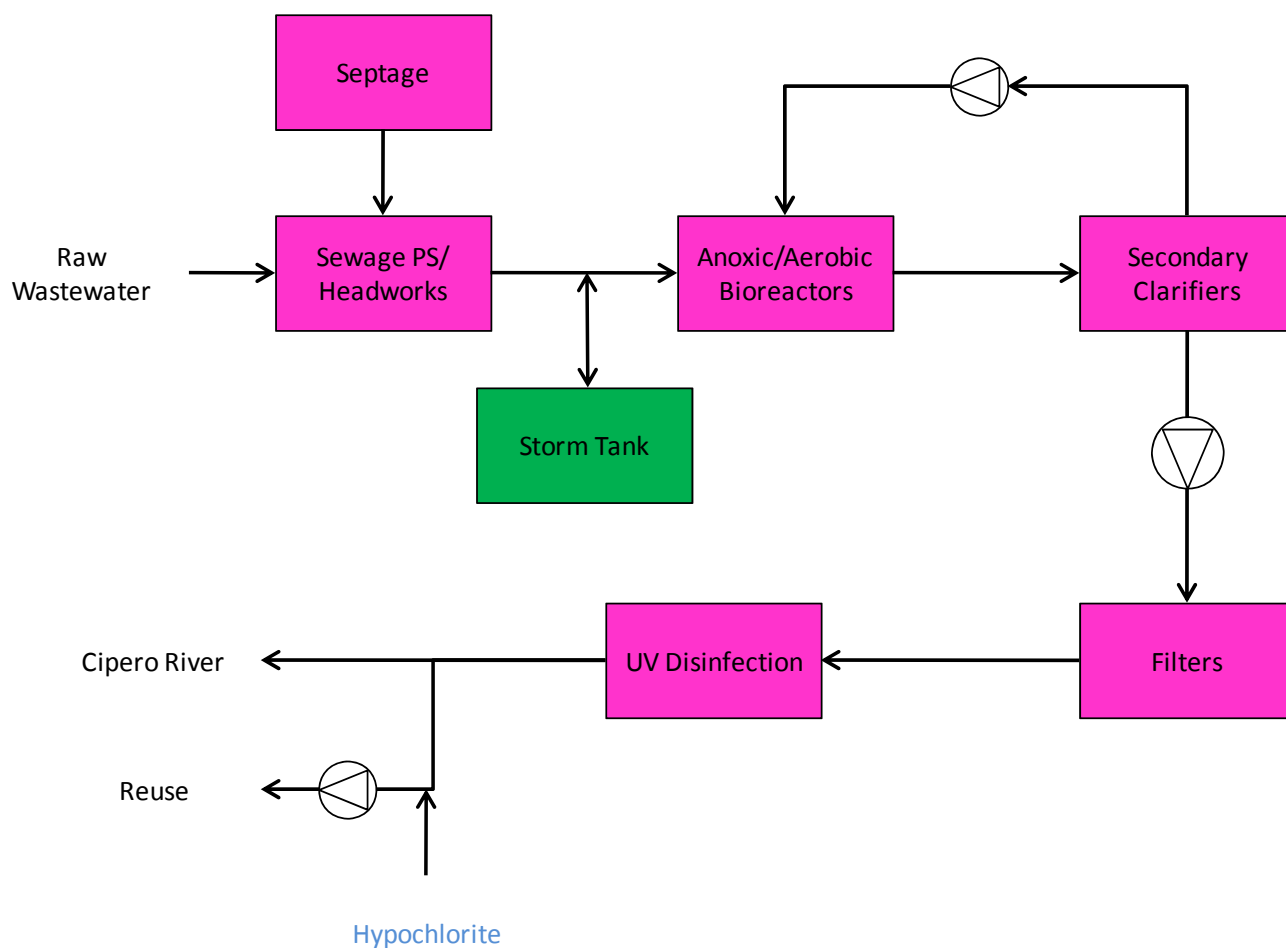


facilities (headworks) will be capable of handling the design PWWF of 158 ML/d. Flows in excess of the PWWF will be diverted to storm water storage facilities until secondary treatment capacity is available. Treated effluent will be discharged to the Ciperó River. Screenings and grit will be washed, dewatered and hauled off site for disposal in a landfill. Waste solids from the activated sludge secondary treatment process will be aerobically digested, dewatered, and hauled off site for disposal.

The treatment scheme for the liquid stream includes the following unit processes:

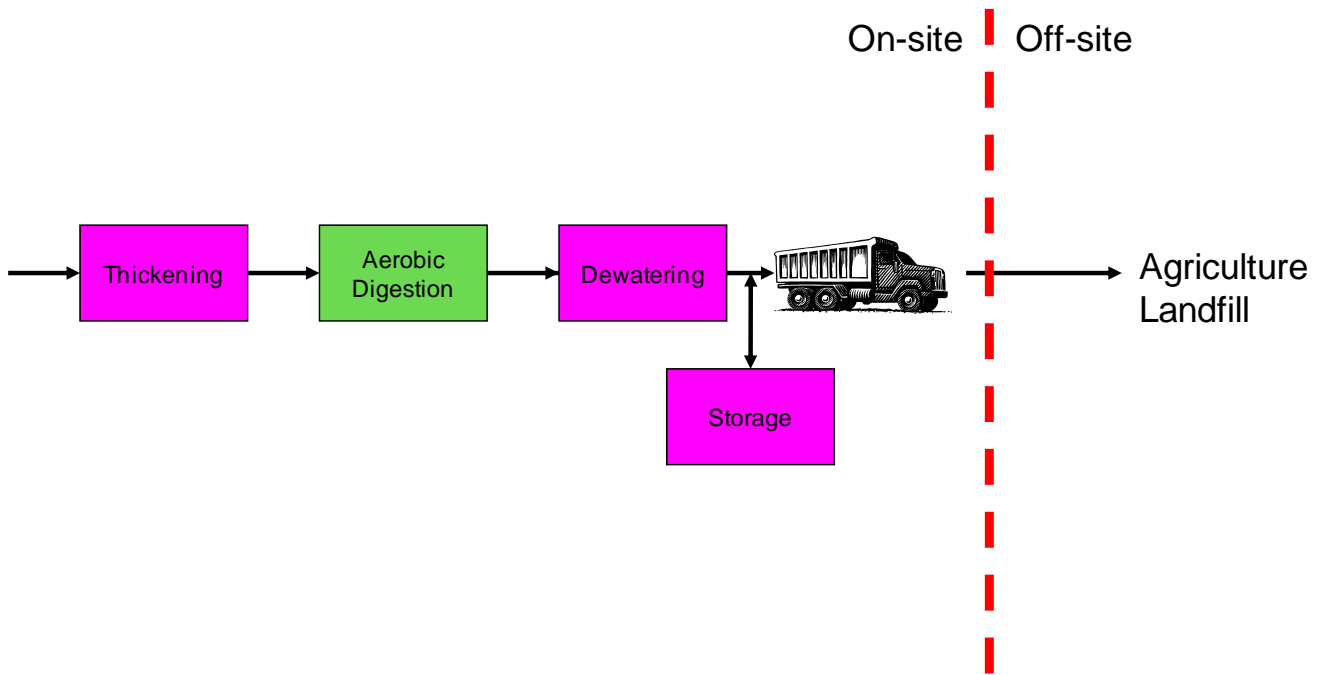
- Influent pumping
- Septage receiving
- Fine screening
- Grit removal
- Storm water storage
- Activated sludge aeration (Bioreactors)
- Secondary clarification
- Return activated sludge (RAS) pumping
- Filtration
- UV disinfection
- Chlorination (Re-use)

The flow schematic of the process is seen below in Figure 3-7.



**Figure 3-7 WWTP Liquids Flow**

The treatment scheme for waste solids from the activated sludge system involves the waste activated sludge being thickened and then aerobically digested. The digested solids will be dewatered and hauled off site. The existing anaerobic digesters will be converted to aerobic digesters. The dewatering facility will consist of a two-story building with belt filter presses located on the second floor. The lower level will be an open area for loading trucks. The facility will also include polymer storage, mixing and feed equipment. Temporary storage of the dewatered cake will be provided on-site in covered trailers. The dewatered cake will be taken off-site for either agricultural reuse or disposed of in a landfill. A flow schematic of the solids process is seen in Figure 3-8 below.



**Figure 3-8 WWTP Solids Flow Schematic**

Figure 3-9 is a Process Flow Diagram showing both the liquid and solids treatment schemes. The layout of facilities on the site of the existing WWTP is shown on Figure 3-10. Operations and laboratory functions will be housed in an Administration Building. Workshops and offices for mechanical electrical and instrumentation maintenance will be located in a Utility Building.

Three water systems will be provided on the plant site as follows:

- Potable Water (W1) Storage and Pumping Station
- Non-Potable Water (W2) Storage and Pumping Station
- Disinfected Secondary Effluent Water (W3) and Pumping Station

A water balance flow diagram is provided in Figure 3-11.

A full description of each treatment process is provided in the remainder of Section 3.9

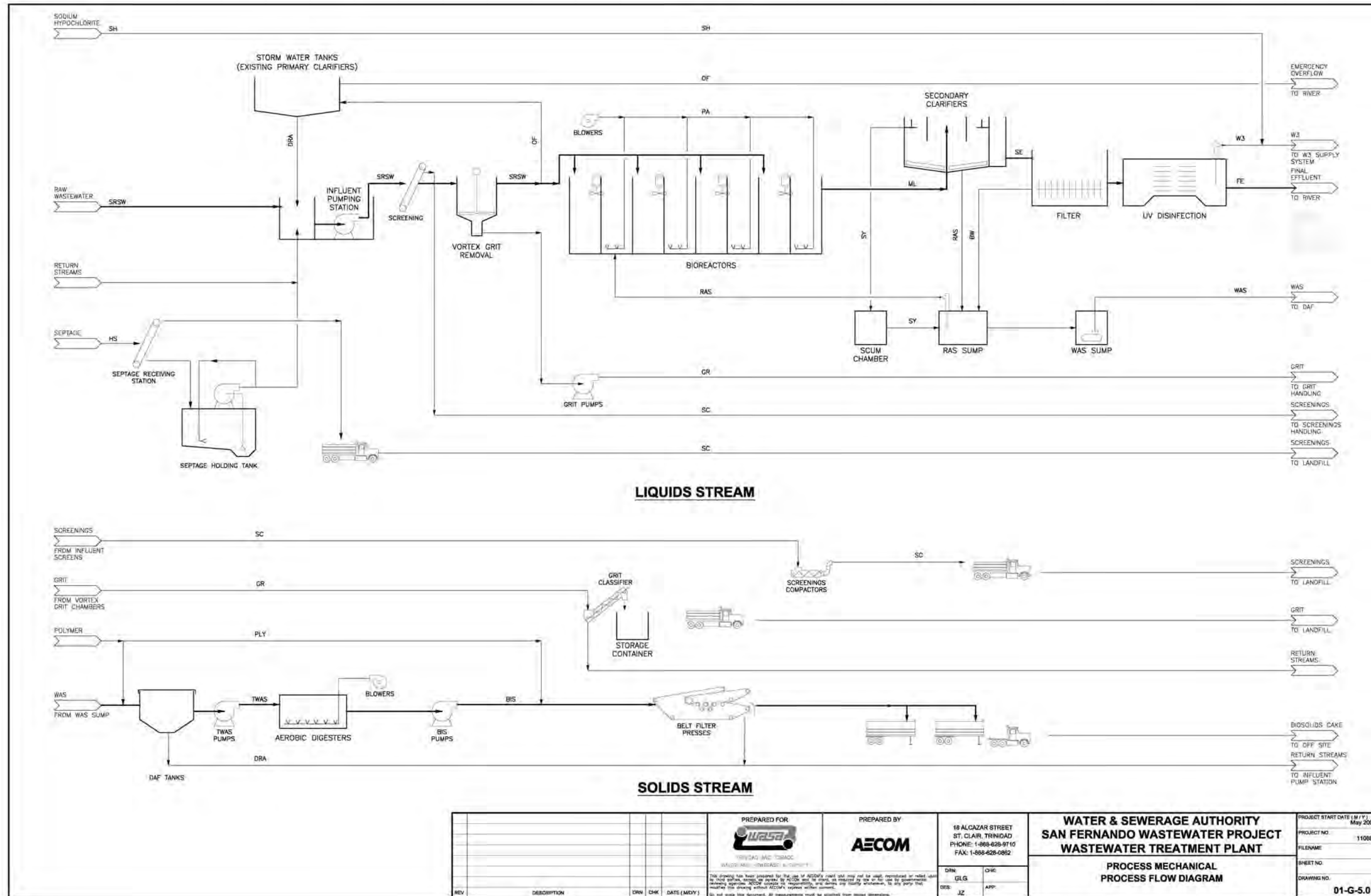


Figure 3-9 WWTP Process Flow Diagram

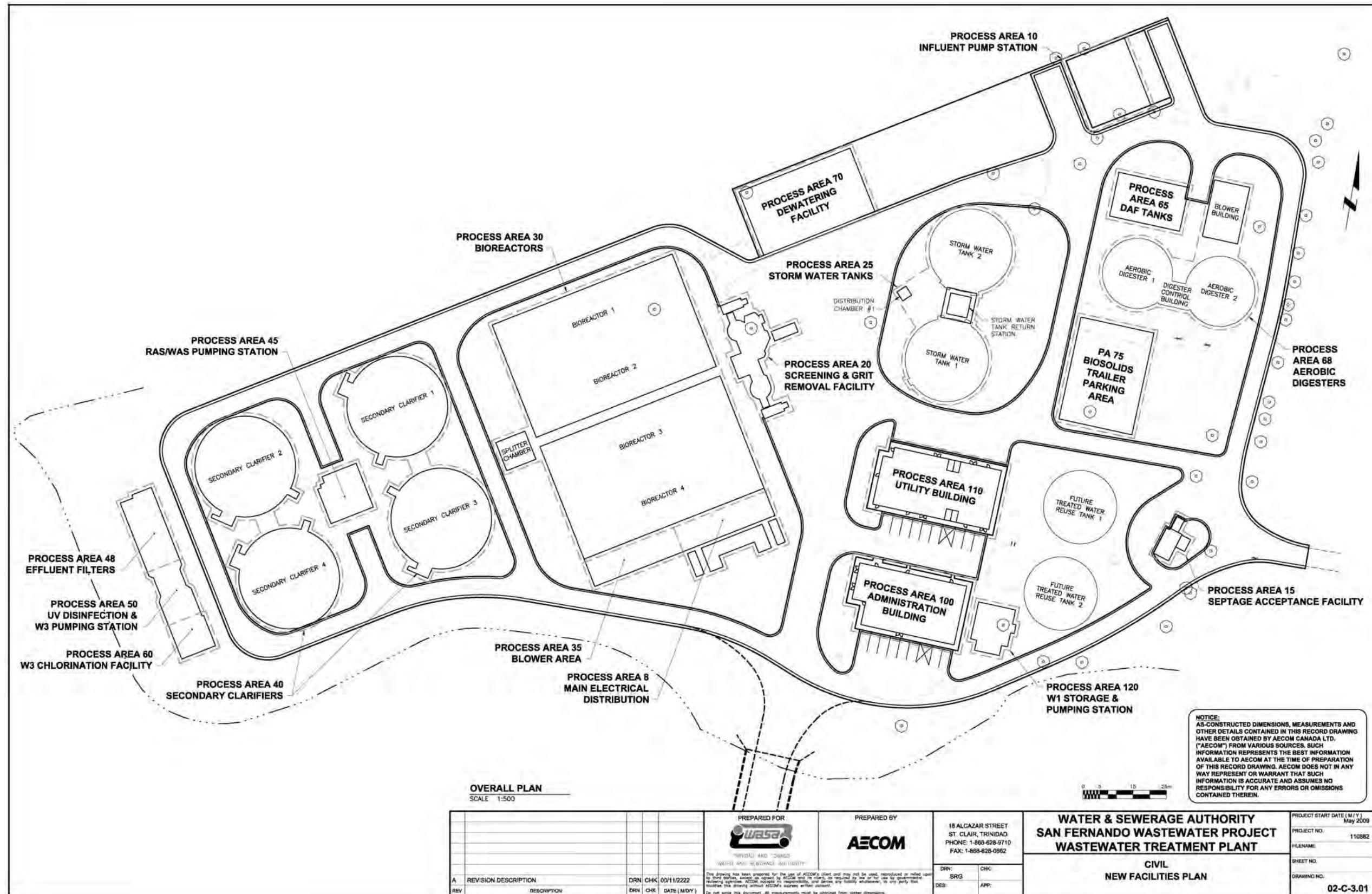


Figure 3-10 WWTP Site Plan



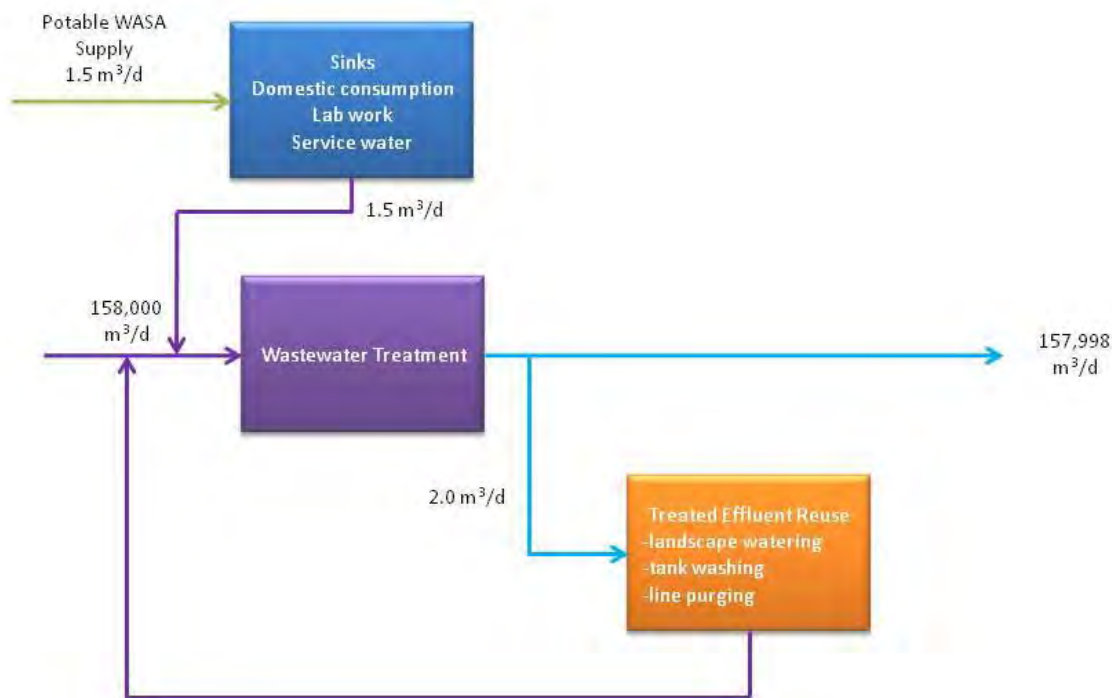


Figure 3-11 Water Balance Flow Schematic for San Fernando WWTP

### 3.9.1 Influent Pump Station

The incoming raw wastewater will enter the plant site from the north and the south and be combined in a junction structure upstream of the influent pumping station. Flow from the junction structure to the influent pumping station will be through two pipes feeding two wet wells. Sluice gates will be provided on each feed pipe and between the two wet well cells. Normal operation will be with all gates open to allow the system to operate as a single wet well. One of the feed gates and the gate between the wet well cells could be closed so maintenance can be performed in one of the wet well cells.

A series of dry pit submersible pumps, mounted in a drywell, pump raw wastewater from the wet wells to the screening system (Figure 3-12).



**Figure 3-12 Dry Pit Submersible Pumps (Chicago Pump)**

A lifting crane is mounted above ground level to raise the pumps from the drywell for maintenance.

Pumps are required to lift the wastewater to an elevation sufficient to allow it to flow by gravity alone through the entire plant to the outfall.

Three pumps are installed for each wet well (total of six pumps) each rated at about 460 L/s. The entire peak flow can be accommodated with two pumps out of service as standby pumps. Flow into a wastewater treatment plant is not constant, but varies with the time of day and season. Therefore, each pump will be equipped with a variable speed drive so that it can match its output as closely as possible to the actual rate of inflow. A level sensor and a controller will maintain a relatively constant water level about the normal water level in the wet well, by controlling the pump speed.

### 3.9.2 Septage Receiving

The septage receiving station will be located on the south east corner of the site, which facilitates the ability for this to be constructed first in the project construction. The new septage receiving station is needed right away so the existing station can be demolished to make space for the new bioreactors. Waste haulers will connect to a pipe that transfers septage into the package septage plant (Figure 3-13). The septage acceptance plant consists of a rock trap and a 6 mm screen.

The screenings, consisting of rags, sticks, and other objects that do not pass through the screens, will be washed and dropped into a dumpster for off-site disposal. Offsite disposal will be in a landfill. The quantity of material removed is dependent on the amount of wastewater received by truck and the characteristics of the septage. The estimated quantity leaving the site would be 1 m<sup>3</sup>/week.

The washed screenings will be contaminated and must be handled and disposed of properly. This is a standard procedure used at WWTPs. Operations personnel will be trained in proper practices so risk is minimized.

The liquids will flow into an underground storage tank located beneath the receiving station. The storage tank will allow for feeding the high strength waste into the treatment plant over time to reduce shock loadings. The liquid will be pumped to the influent pump station.

The design of the septage receiving station is enclosed, with odour suppression equipment. Air vented from the station will pass through an activated carbon filter.



**Figure 3-13 Package Septage Receiving Unit (Courtesy of JWC Environmental)**

### 3.9.3 Fine Screens

Two outdoor influent screens will be mounted above ground level. Each will have a capacity of 158 ML/d. The screens will be band screens with 6 mm openings (Figure 3-14). A wiper removes screenings from the screen and drops the screenings into its dedicated compactor mounted below the discharge point of the screen. Each of the two compactors (Figure 3-15) reduces the moisture content of the material, raising the solids concentration from approximately 15% to 40%. The compactor consists of a screw conveyor that drives the material into a converging cone section. As the material is 'squeezed' into the cone, water is ejected and is drained to the influent channel. Compacted screenings discharge into a dumpster. The dewatered screenings are hauled off-site for disposal. The quantity of material removed is dependent on the wastewater characteristics.

Compressed air will be provided to supply air to a coarse bubble aeration system in the channels ahead of the screens to minimize settlement of grit under low flow conditions.



**Figure 3-14 Band – Type Fine Screen (Courtesy of JWC Environmental)**



**Figure 3-15 Screenings Compactor (Courtesy of Huber Technology)**

### 3.9.4 Grit Removal

The screened wastewater will be conveyed in channels to the grit removal area. Grit will be removed by two mechanically induced vortex grit removal chambers. These chambers are designed to remove greater than 80% of the silt, sand, and other inert material greater than 0.25 mm in size. The de-gritted effluent continues to the bioreactor, while the collected grit is dewatered in a cyclone classifier to approximately 75% solids content and stored for offsite disposal. Three facilities associated with grit removal are as follows:



- Vortex Grit Removal Chambers – Vortex grit removal chambers exploit the difference in density between inorganic (grit) and organic solids to separate the two materials and preferentially remove the grit from the process stream.
- Grit Pump – Grit slurry is removed from the bottom of each grit chamber by a recessed impeller solids-handling centrifugal pump.
- Grit classifier – Grit slurry is pumped from the vortex chambers to two grit classifier and dewatering systems. Each system consists of cyclones (one per connected pump), a clarifier tanks, and dewatering screw conveyor.

### 3.9.5 Flow Measurement and Wet Weather Storage

The flow from the grit tanks will be directed to a distribution chamber, where the wastewater will be directed to the bioreactors and to the stormwater storage tanks if the flow exceeds the capacity of the secondary treatment system. The distribution chamber will use adjustable weirs to allow the flow split to be altered when a bioreactor is taken out of service.

Signals from magnetic flow meters in the feed pipes to the bioreactor will be used to modulate an actuated gate that controls flow to the storm water tank. When the total flow to the plant exceeds 90 ML/d, the actuated weir gate will modulate to limit the flow to the bioreactors to 90 ML/d. Bypassed flows will be directed to storm water storage tanks.

### 3.9.6 Storm Water Storage

The storm water storage facility will provide storage during extreme wet weather events. Once the storm event has subsided, the contents of the storage facility would be gradually returned to the headworks for treatment. Septic conditions should not arise, as provisions will be made for manual flushing of the Storm Water Tank once it has been drained.

The two 23m diameter existing primary clarifiers (Figure 3-16) will be converted to storm water tanks. With a sidewall depth of 2.75 m and a floor slope of 1:12, the two clarifiers provide a total volume of 2512 m<sup>3</sup>, which corresponds to 50 minutes of storage during the peak instantaneous flow to the WWTP of 158 ML/d. This storage volume is expected to contain all storms considering that the majority of the collection system will be new and I&I should be minimized.



**Figure 3-16 Recently Refurbished Primary Clarifiers at San Fernando WWTP**

### 3.9.7 Bioreactors

Biochemical reactions in the bioreactor convert the organics in the wastewater to respiration products ( $\text{CO}_2$  and  $\text{H}_2\text{O}$ ) and cellular material. The residual organic levels following solids separation are sufficiently low to render the treated wastewater acceptable for discharge. In addition, nitrogen concentrations are reduced by nitrification-denitrification. Nitrification is the oxidation of ammonia to nitrate, and denitrification is the conversion of nitrate to nitrogen gas.

The bioreactor structure comprises four equally sized parallel aeration systems. With a total volume of  $44,100 \text{ m}^3$ , the hydraulic retention time (HRT) at the ADWF is 10 days. System solids retention time (SRT) will be controlled at a minimum of 10 days. A portion of each bioreactor will be mixed and not aerated to promote denitrification reactions. Simultaneous nitrification-denitrification (SND) in zones aerated by fine bubble diffusers (Figure 3-17) will reduce effluent nitrate concentrations. Mixed liquor recycle pumping is provided to increase the level of denitrification and meet the total nitrogen limit.



**Figure 3-17 Fine Bubble Aeration Bioreactor**

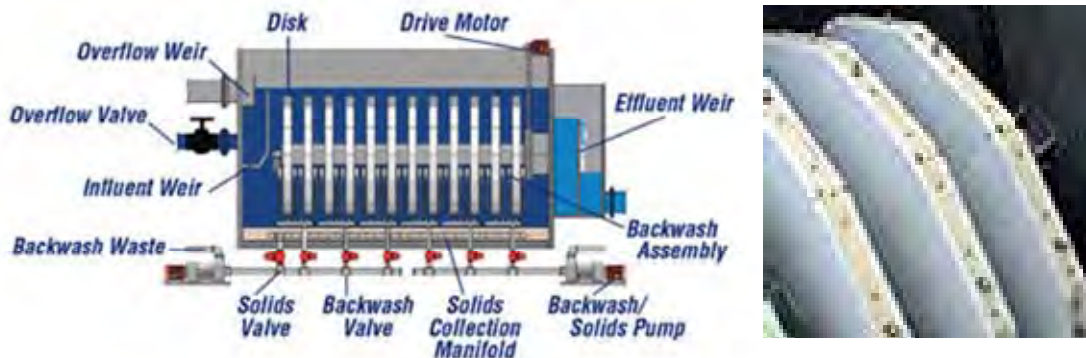
### 3.9.8 Secondary Clarifiers

Mixed liquor from the bioreactor is divided in a splitter box and conveyed to four secondary clarifiers. The clarifiers separate the mixed liquor into RAS, which settles to the clarifier floor and is returned to the bioreactor, and secondary effluent, which proceeds to filtration, disinfection and final discharge.

Each secondary clarifier is a circular reinforced concrete tank. They are each equipped with a full radius suction header mechanism that removes the settled sludge to a common wet well for withdrawal by the return activated sludge pumps. Each of the four clarifiers is 29 m in diameter, with a 6.0 m side water depth (SWD).

### 3.9.9 Filtration

To produce an effluent with a low TSS concentration suitable for reuse, a filtration process is required. Disc filters will be provided. In this process the water passes through a series of rotating cloth-covered or mesh-covered discs (Figure 3-18) into a central collection header. The filtered effluent exits the central header via a chamber equipped with an overflow. Backwashing is conducted in-situ while the discs are rotating. A series of suction shoes are used to vacuum the solids off the surface of the disc.



**Figure 3-18 Cloth Media Filter (Courtesy of Aqua-Aerobic Systems)**

Figure 3-19 shows an example of a cloth media filtration plant. For the San Fernando WWTP, five packaged filtration units will be installed. The system is sized so that the PWWF can be handled by only four units.



**Figure 3-19 Cloth Media Filtration Plant (Courtesy of Aqua-Aerobic Systems)**

### 3.9.10 UV Disinfection

Disinfection reduces levels of pathogens in the final effluent to meet discharge regulations stipulated by the Environmental Management Authority of less than 400 Faecal Coliform/100 mL.

The recommended disinfection system consists of a low pressure, high intensity ultraviolet (UV) irradiation system. The UV system will be sized to disinfect up to 90 ML/d (peak secondary treatment flow) to less than 25 N/100 mL Faecal Coliform.

Secondary effluent is split between two UV channels. Manual slide gates at the head of each channel can be used to isolate a channel when it is not required or when maintenance needs to be performed. Each channel is equipped with an array of UV lamps, arranged parallel to the flow. A weir downstream





maintains constant lamp submergence, regardless of flow. If the level drops so that the lamps are exposed, the system shuts off to prevent damage to the lamps.

The disinfected secondary effluent flow discharges from the UV facility through a channel that enters a parshall flume. This flume measures the flow out of the plant, maintains upstream water levels, and sends a signal to the UV system controls. The flume discharges into a chamber, which directs flow into an outfall pipe that conveys the treated effluent to the Cipero River. A connection is also provided for diverting the effluent water to a future reclaimed water pumping station.

### 3.9.11 Secondary Sludge Pumping

#### 3.9.11.1 Return Activated Sludge (RAS) Pumps

Return activated sludge (RAS) will be withdrawn from each clarifier via a magnetic flow meter and weir gate. The elevation of the weir gate is automatically adjusted to vary the RAS flow based on the signal from the flow meter. The overflow from each weir gate discharges into a common RAS well. A series of pumps transfer the RAS from the wet well to inlet end of the bioreactors. This arrangement for RAS pumping means that RAS pumping capacity is independent of the number of clarifiers in operation. If one clarifier is taken out of service, there is no reduction in the number of available RAS pumps.

Three RAS pumps will be provided (two on duty, and one standby). The pumps convey the RAS, via a common header, to the RAS splitter box. This box directs the RAS flow to the four bioreactor modules.

#### 3.9.11.2 Waste Activated Sludge Pumps

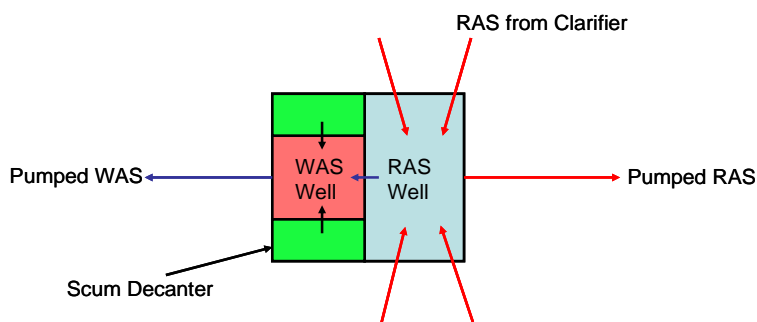
Waste activated sludge (WAS) is removed via a separate WAS wet well, and pumping system. A penetration between the WAS wet well and the RAS wet well allows RAS to flow into the WAS tank when the WAS pumps are running. Scum collected from the surface of the clarifiers is also directed to the WAS wet well. The WAS and scum in the WAS wet well are kept in suspension by mixers.

WAS and scum will be conveyed from the WAS wet well to the dissolved air flotation thickeners using three (two duty, one standby) interconnected variable speed WAS pumps.

#### 3.9.11.3 Scum Decanters

Each pair of secondary clarifiers will be served by one scum decanter. The WAS wet well will be located between the two decanter boxes. The scum decanter consists of a concrete box equipped with a manually operated weir gate, and an adjustable telescopic valve. Scum will be manually removed from the decanters by lowering of the weir gates. The subnatant (water) from the decanters will be removed via the telescopic valve. Each revolution of the secondary clarifier mechanism results in a slug of water and scum being conveyed to the decanter. The scum floats to the surface, and the subnatant overflows via the standpipe to the plant drain piping that discharges to the wet well of the plant influent pumping station.

A schematic of the WAS, RAS and scum decanter system is provided in Figure 3-20.



**Figure 3-20 WAS, RAS, and Scum Decanter Schematic**

### 3.9.12 Sludge Thickening

It is necessary to thicken the WAS to provide sufficient retention time in the aerobic digesters. Dissolved air flotation (DAF) will be used for sludge thickening. DAF introduces fine air bubbles to the sludge, which attach to the solids and cause them to rise to the surface where they form a thickened froth, which is collected by a skimming mechanism. This process does not require polymer, and is typically operated unmanned during the night and at weekends.

The main components of a DAF thickener system are the pressurization system and the DAF tank (Figure 3-21). The pressurization system includes a recycle pressurization pump, an air compressor, and a backpressure control valve. The DAF tank is equipped with a surface skimmer. A bottom sludge removal mechanism will not be required because the sludge source is a suspended growth secondary treatment system.

For the San Fernando WWTP, two pre-fabricated stainless steel DAF tanks will be provided (each 3.5 m wide by 20 m long). Under normal operating conditions, both tanks will operate without polymer addition, and will thicken the WAS to about 3% dry solids. The DAF tanks will be equipped with covers and will be located outdoors adjacent to the aerobic digesters.



**Figure 3-21 Stainless Steel DAF Tank**

If one of the DAF tanks is out of service for maintenance, or if there is an unexpected temporary lapse in performance, polymer can be added to improve the capture rate thereby increasing the solids loading capacity and stabilizing the DAF operation significantly.

Thickened WAS will be pumped by progressive cavity pump to the aerobic digesters.

### 3.9.13 Aerobic Digestion

The two existing anaerobic digesters will be converted into aerobic digesters. Each digester has a volumetric capacity of 2400 m<sup>3</sup>, to give a total capacity of 4800 m<sup>3</sup>.

With thickened WAS at a solids concentration of 3%, the retention in the digesters will be 15 days, in accordance with WASA Guidelines. With testing, USEPA Guidelines to meet a Class B Sludge are expected to be met.

The aerobic digesters will be aerated by coarse bubble aeration devices. Air will be supplied by a series of fixed speed positive displacement blowers in acoustic enclosures. The air will be cycled on and off to provide anoxic conditions for denitrification of nitrate generated during the digestion process. Mixers will be used to mix the digesters during the anoxic stages.

Digested solids (biosolids) will be pumped to the dewatering system.

### 3.9.14 Sludge Dewatering and Loadout

The biosolids will be dewatered before removal from the WWTP site to minimize truck traffic through the surrounding neighbourhoods. To minimize footprint and complexity, a two storey building will be provided, with the dewatering equipment located on the upper floor. Cake from the dewatering equipment would drop down a chute into truck trailers parked at grade level. During change-out of the



trailers, the dewatering equipment will need to be stopped. With 20 tonne capacity trailers, it is expected that approximately 25 trailers would be required per week.

The dewatered cake will be hauled off-site for agricultural reuse, or to landfill. A paved trailer storage area will be provided that will allow WASA to temporarily park biosolids-laden trailers covered with tarps, in the event of an emergency.

Thickened and digested biosolids will be pumped from the digesters to three belt filter presses (BFP) (2 on duty, 1 standby) (Figure 3-22). In the belt filter press the solids content is increased from approximately 2% solids to between 10 to 15% solids. The belt filter presses are three-belt units consisting of one gravity belt followed by two pressure belts. The gravity and pressure sections are operated independently to optimize the thickening and dewatering functions within a single unit. The gravity section thickens the liquid biosolids by removing a majority of the water. The thickened biosolids then feed the pressure section where the two belts are routed through a serpentine path between a series of rollers. As the sludge travels along the dewatering path, pressure is increased, expelling water from the material. On their return travel, the three belts are washed by a flow of clean water. All liquid waste from the belt filter press will travel by gravity to the influent pumping station. From the influent pumping station, it will be treated in the WWTP.



**Figure 3-22 Three Belt Filter Press (courtesy of Andritz)**

It will be necessary to store solids during night time hours and over weekends when the dewatering equipment is not operating. Three options will be available to plant operations:

- Draw down the digesters during weekday operations of the BFPs to make room for solids wasted at night and on weekends.
- Suspend solids wasting at night and on weekends thereby storing the solids in the bioreactors.
- Approximately one day of storage for dewatered biosolids will be provided. The storage will be in covered trailers parked in a paved area on site.



### 3.9.15 Wastewater Reuse Option

The design of the WWTP incorporates tertiary treatment processes for effluent reuse and has allowances on the site layout for future works related to pumping the reuse water to future customers.

The filtered and UV disinfected water will be directed to a chlorination system that feeds sodium hypochlorite solution. The chlorinated effluent will flow by gravity to one or both of the existing secondary clarifiers. These existing secondary clarifiers would be used as chlorine contact chambers, and will also act as a wet well for the future reuse transfer pumps. These pumps will transfer the water to the end-user.

The design of the WWTP includes space in the hypochlorite room for the addition of hypochlorite tanks for effluent reuse disinfection. The design also includes a 750mm diameter pipeline from the UV facility to the future chlorine contact chamber and pumping facility.

### 3.9.16 Chlorination Facility

#### 3.9.16.1 Plant Re-use Water

A small portion of the effluent will be recycled within the plant for various purposes such as landscape watering, tank flushing, and line purging. This plant reuse water will be chlorinated for the protection of the operators, through sodium hypochlorite dosing. Sodium hypochlorite has been chosen due to its low risk on personnel injury or environmental damage. The hypochlorite solution will be delivered in 1m<sup>3</sup> totes. A maximum of four totes will be on site at once. These totes will be stored so that in the event of spills, the liquid will be contained and not released to the environment. All spills will be flushed into the wastewater drainage system for treatment through the WWTP. The MSDS for sodium hypochlorite has been included in **Appendix C.1**.

#### 3.9.16.2 Reuse Water Option

The use of the treated effluent for reuse would require the dosing with sodium hypochlorite; however, the amount is unknown at this time due to the unknowns with the amount of water to be used for reuse purposes. The sodium hypochlorite would be stored in the same location as the totes used for plant reuse water. In the event of spills, the liquid will be contained and not released to the environment. All spills will be flushed into the wastewater drainage system for treatment through the WWTP.

### 3.9.17 Polymer Addition

Polymer addition will be required for the belt filter press dewatering operation, and occasionally for the DAF system during maintenance, or temporary lapse in performance. The actual polymer will be selected when testing is done during plant commissioning; however, a MSDS for the polymer typically used is enclosed in **Appendix C.2**. Polymer will be delivered in bags or barrels and will be stored on pallets in a dry storage room. All proper MSDS requirements will be followed for storage and handling.

### 3.9.18 Utility Requirements

As the new San Fernando WWTP is to be constructed on the site of the existing WWTP, most utilities are already established and installed. Additional electrical feeder lines from T&TEC will be required to meet the increased load for the larger WWTP capacity. Redundant feeder lines will be provided from



two substations for maximum reliability. Standby generators will also be provided to power the entire plant in the event that T&TEC power is lost.

### 3.9.19 Design Summary

Table 3-11 summarizes the design criteria, unit process capabilities, and equipment details for the new San Fernando WWTP.

**Table 3-11 San Fernando Wastewater Treatment Plant Design Data**

Item	Units	Value
<b>Raw Wastewater Characteristics</b>		
Flow		
ADWF	ML/d	45
AWWF	ML/d	90
PWWF	ML/d	158
Total Loads		
BOD		
Average	kg/d	7,900
Maximum month	kg/d	9,240
COD		
Average	kg/d	17,360
Maximum month	kg/d	20,310
TSS		
Average	kg/d	11,150
Maximum month	kg/d	14,380
TN		
Average	kg/d	1,560
Maximum month	kg/d	1,750
TP		
Average	kg/d	215
Maximum month	kg/d	250
<b>Final Effluent – Reuse</b>		
Monthly Arithmetic Average		
COD	mg/L	250
BOD	mg/L	20
TSS	mg/L	5
Total Oil & Grease	mg/L	10
TN	mg/L	15



**Table 3-11 San Fernando Wastewater Treatment Plant Design Data (continued)**

Item	Units	Value
TP	mg/L	5
DO	mg/L	>4
pH		6 to 8.5
Residual Chlorine	mg/L	>1.0
Monthly Geometric Mean	mg/L	20
Faecal Coliforms	N/100 mL	25
<b>Raw Wastewater Pumps</b>		
Number		6
Capacity	L/s	460
Head	m	23
Power	kW	150
<b>Septage Acceptance Plant</b>		
Number		1
Capacity	L/s	15
Screen Size	mm	6
Power	kW	1.5
<b>Septage Holding Tank</b>		
Width	m	4.1
Length	m	7.9
Depth	m	2.8
Volume	m <sup>3</sup>	94
<b>Mixing/ Transfer Pumps</b>		
Number		2
Capacity	L/s	6
Power		7.5
<b>Screening</b>		
Number		2
Opening Size	mm	6
Capacity per screen	ML/d	158
Dimensions		
Width, m	m	0.94
SWD, m	m	3.80
Screenings Quantities (wet)		
Average	kg/d	3,240
Maximum	kg/d	32,400



**Table 3-11 San Fernando Wastewater Treatment Plant Design Data (continued)**

Item	Units	Value
<b>Compactors</b>		
Number		2
Capacity	m <sup>3</sup> /hr	0.5
<b>Compacted Screenings Quantities (wet)</b>		
Average	kg/d	1,215
Maximum	kg/d	12,150
<b>Grit Removal</b>		
Type		Vortex
Number		2
Capacity	ML/d	80
<b>Dimensions</b>		
Diameter	m	5.48
Depth	m	8.10
<b>Grit Pumps</b>		
Number		2
Capacity per pump	m <sup>3</sup> /h	57
Power	kW	6
<b>Classifiers</b>		
Number		2
Capacity	m <sup>3</sup> /h	0.3
<b>Dewatered Grit Quantities</b>		
<b>Dry Solids</b>		
Average	Tonnes/d	2
Maximum	Tonnes/d	20
<b>Volume</b>		
Average	m <sup>3</sup> /d	1.6
Maximum	m <sup>3</sup> /d	16
<b>Storm Water Storage Tanks</b>		
Peak Flow	ML/d	68
Peak Overflow Rate (OFR)	m <sup>3</sup> /m <sup>2</sup> /d	166
Number		2
<b>Dimensions</b>		
Diameter	m	22.9
SWD	m	3.90
Volume	m <sup>3</sup>	1600





**Table 3-11 San Fernando Wastewater Treatment Plant Design Data (continued)**

Item	Units	Value
<b>Bioreactors</b>		
Peak Flow	ML/d	90
Basic Design Parameters <sup>1</sup>		
SRT	d	10
HRT	d	13
MLSS – Aerobic Zone 1	mg/L	6,100
MLSS – Aerobic Zone 2	mg/L	5,000
MLSS – Aerobic Zone 3	mg/L	4,200
MLSS – Aerobic Zone 4	mg/L	3,200
Number of Bioreactors		4
Volume per Bioreactor	m <sup>3</sup>	5,970
Pre- Anoxic Cells		
Number per Bioreactor		1
Volume per cell	m <sup>3</sup>	70
Anoxic Cells		
Number per Bioreactor		3
Volume per cell	m <sup>3</sup>	543
Aerobic Cells		
Number per Bioreactor		4
Volume – Aerobic Zone 1	m <sup>3</sup>	1,016
Volume – Aerobic Zone 2	m <sup>3</sup>	1,085
Volume – Aerobic Zone 3	m <sup>3</sup>	1,085
Volume – Aerobic Zone 4	m <sup>3</sup>	1,085
Dimensions		
SWD	m	7
<b>Anoxic Cell Mixers</b>		
Total number of Mixers		16
Total number of Pre-anoxic Mixers		4
Total number of Anoxic Mixers		12
Number of Mixers per Anoxic Zone		1
Power Per Pre-anoxic Mixer		0.56
Power Per Anoxic Mixer	kW	2.2
<b>Diffused Aeration</b>		
Type		Fine Bubble
Alpha Factor		
Aeration Zone 1		0.63
Aeration Zone 2		0.68



**Table 3-11 San Fernando Wastewater Treatment Plant Design Data (continued)**

Item	Units	Value
Aeration Zone 3		0.72
Aeration Zone 4		0.78
Field Oxygen Demand		
Average per basin	kgO <sub>2</sub> /d	4,560
Maximum per basin	kgO <sub>2</sub> /d	6,080
Aeration Zone 1		
Average	kgO <sub>2</sub> /d	1,440
Maximum	kgO <sub>2</sub> /d	1,920
Aeration Zone 2		
Average	kgO <sub>2</sub> /d	1,080
Maximum	kgO <sub>2</sub> /d	1,440
Aeration Zone 3		
Average	kgO <sub>2</sub> /d	1,800
Maximum	kgO <sub>2</sub> /d	2,400
Aeration Zone 4		
Average	kgO <sub>2</sub> /d	960
Maximum	kgO <sub>2</sub> /d	1,280
Standard Oxygen Demand		
Average per basin	kgO <sub>2</sub> /d	8,856
Maximum per basin	kgO <sub>2</sub> /d	11,832
Aeration Zone 1		
Average	kgO <sub>2</sub> /d	3,072
Maximum	kgO <sub>2</sub> /d	4,104
Aeration Zone 2		
Average	kgO <sub>2</sub> /d	2,136
Maximum	kgO <sub>2</sub> /d	2,856
Aeration Zone 3		
Average	kgO <sub>2</sub> /d	1,800
Maximum	kgO <sub>2</sub> /d	2,400
Aeration Zone 4		
Average	kgO <sub>2</sub> /d	1,848
Maximum	kgO <sub>2</sub> /d	2,472
<b>Aeration Blowers</b>		
Type		Pos. Disp.
Number		6
Capacity	Nm <sup>3</sup> /min	47
Discharge Pressure	kPa	90
Motor Size	kW	110



**Table 3-11 San Fernando Wastewater Treatment Plant Design Data (continued)**

Item	Units	Value
<b>Secondary Clarifiers</b>		
Overflow Rate (OFR)		
Average	m/h	0.7
Maximum	m/h	1.4
Solids Loading Rate (SLR <sub>pk</sub> )		
Average	kg/m <sup>2</sup> /h	3.5
Maximum	kg/m <sup>2</sup> /h	5.4
Number		4
Dimensions		
Diameter	m	29
SWD	m	6
<b>Filtration</b>		
Type		Cloth Discs
Number of filter cells		5
Number of discs per filter cell		12
Filter Area per disc	m <sup>2</sup>	5
<b>UV Disinfection</b>		
Peak process capacity	ML/d	90
Peak hydraulic capacity	ML/d	90
No of channels		2
Banks per channel		1
Lamps per bank		208
UV reduction equivalent dosage	mWs/cm <sup>2</sup>	35
UV transmittance	%	60
Power	kW	52
<b>Return Activated Sludge (RAS) Pumps</b>		
Number		3
Capacity	L/s	350
TDH	m	15
Power	kW	55



**Table 3-11 San Fernando Wastewater Treatment Plant Design Data (continued)**

Item	Units	Value
<b>Waste Activated Sludge (WAS) Pumps</b>		
Number		2
Capacity	L/s	17.4
TDH	m	17.6
Power	kW	11
<b>Waste Sludge Characteristics</b>		
Solid Loads		
Average	kg TSS/d	8,850
Maximum	kg TSS/d	11,050
Volatile Suspended Solids		
Average	kg VSS/d	4,150
Maximum	kg VSS/d	4,980
Concentration	%	0.5 to 1.0
Maximum Flow	m <sup>3</sup> /d	1,500
<b>Dissolved Air Flotation Thickeners</b>		
Number		2
Width	m	4.3
Length	m	14.6
Depth	m	3.4
Maximum Flow	ML/d	1.5
Peak solids loading	kg/hr.m <sup>2</sup>	4.39
TWAS Concentration	%	2-4
<b>Aerobic Digesters</b>		
Number		2
Volume, each digester	m <sup>3</sup>	2,000
Solids Concentration	%	3
Solids Loading after digestion		
Average	kg TSS/d	7,670
Maximum	kg TSS/d	9,700
Volatile Suspended Solids		
Average	kg VSS/d	3,120
Maximum	kg VSS/d	3,790
Alpha Factor		0.15
Retention Time	d	15
OTR	kgO <sub>2</sub> /d	2,326
SOTR	kgO <sub>2</sub> /d	8,971
Specific O <sub>2</sub> Uptake Rate – SOUR	mg/hr/gTSS	1.5



**Table 3-11 San Fernando Wastewater Treatment Plant Design Data (continued)**

Item	Units	Value
<b>Digester Mixers</b>		
Number per tank		1
Motor size	kW	30
<b>Digester Blowers</b>		
Type		Pos. Disp.
Number		6
Capacity	Nm <sup>3</sup> /min	70
Discharge Pressure	kPa	90
Motor size	kW	187.5
<b>Belt Filter Presses</b>		
Total Number		3
Duty		2
Standby		1
Weekly operation	d/week	5
Daily operation	h/d	8
<b>Solids loads</b>		
Average	kg/d	10,738
Maximum	kg/d	13,580
<b>Solids concentration</b>		
Inlet	%	2-4
Outlet	%	15-20
Belt width each unit	m	3
Solids loading	kg/m/h	300
Hydraulic loading	m <sup>3</sup> /m/h	8
Minimum solids capture	%	95
<b>Belt Drives</b>		
Number of drives per unit		3
Power	kW	9.3
<b>Belt washwater</b>		
Flow per unit	L/s	2.5
Pressure	kPa	800
<b>High Pressure Booster Pump</b>		
Number of pumps		3
Flow per unit	L/s	7.5
Head	m	82
Power	kW	5.6



**Table 3-11 San Fernando Wastewater Treatment Plant Design Data (continued)**

Item	Units	Value
<b>Compressed Air</b>		
Flow per unit	Nm <sup>3</sup> /h	1
Pressure	kPa	1,000
<b>Compressor</b>		
Number of compressors		2
Capacity	Nm <sup>3</sup> /h	10
Pressure	kPa	1,000
Power	kW	2.2
<b>Polymer System</b>		
Number of make-up systems		1
Number of storage tanks		1
<b>Polymer dosage</b>		
Average	kg/t	10
Maximum	kg/t	20
<b>Hourly polymer load</b>		
Average	kg/h	13
Maximum	kg/h	34
<b>Dry polymer Loader Requirement</b>		
Average	kg/week	540
Weekly	kg/week	1,360
<b>Polymer concentration</b>		
After make-up	% w/w	0.5
After addition of carrier water	% w/w	0.1
Volume of mixing tank (each)	L	7,000
Volume of storage tank	L	14,000
Aging time in mixing tank at 0.5 % w/w	min	60
<b>Polymer Dosing Pumps</b>		
Number of pumps		5
Capacity (each)	L/min	60
Design head	m	50
Power	kW	0.75
Dry Polymer Screw Feeder Power	kW	0.18
Dry Polymer Blower Power	kW	1.86
Mixer Power	kW	2.20



**Table 3-11 San Fernando Wastewater Treatment Plant Design Data (continued)**

Item	Units	Value
<b>W1 Water Supply Pumps</b>		
Number		3
Capacity	m <sup>3</sup> /h	12
TDH	m	50
Power	kW	5.5
<b>Storage Reservoir</b>		
	m <sup>3</sup>	450
<b>W3 Water Supply Pumps</b>		
Number		2
Capacity	m <sup>3</sup> /h	110
TDH	m	80
Power	kW	37.5
<b>Hypochlorite Disinfection of W3</b>		
Hypochlorite Concentration	%	8.3
Dosage	mg/l	3.3
Number of Pumps		2
Capacity	L/hr	5.1
Power	kW	0.75
<b>Onsite Storage</b>		
Number		4
Volume per tote	m <sup>3</sup>	1

Note HRT – Hydraulic retention time MLSS – Mixed liquor suspended solids  
 OFR – Overflow rate OTR – Oxygen transfer rate  
 SLR – Solids loading rate SOTR – Standard oxygen transfer rate  
 SOUR – Specific oxygen uptake rate SRT – Solids retention time  
 SWD – Sidewall water depth TDH – Total dynamic head

### 3.10 Collection System Scope of Works

#### 3.10.1 Sewer Piping Network

The proposed wastewater collection system will consist of pipes of various sizes including trunk sewers, local (district) sewers, terminal sewers, service connections and forcemains. Trunk sewers convey PWWF from a subcatchment to another trunk sewer or to the WWTP. Typically, sewers that serve a population of approximately 3,000 pe or exceed a flow of 40 L/s, are designated as trunk sewers. Local or district sewers feed the trunk sewers and theoretically have a peak flow capacity of less than 40 L/s including a nominal allowance for infiltration. Terminal sewers are at the upstream end of the sewer system where the line begins. Service connections are the lateral sewer pipes from the local sewer in roadway to approximately 1 to 2 m inside the property line of a parcel of land. The



service connection includes a junction box at the property line. Forcemains are sewers operating under pressure, which carry flow from a lift station to a gravity sewer discharge point or in some cases another forcemain.

All wastewater from the project area is to be collected and conveyed to one new treatment plant located on the site of the current San Fernando WWTP. Trunk main sewers will collect wastewater from all catchments. The size of the trunk sewers are chosen to match the design flows as closely as possible.

With the overall goal to sewer all properties in the project area, the proposed San Fernando collection system is shown in Figure 3-23. Pipe sizes range from 200mm to 1500 mm diameter.

The collection system is divided into subcatchments as seen on Figure 3-24. Subcatchment boundaries are based on topography and serve two purposes. First, the smaller subcatchments make it easier for operations and maintenance personnel to understand how the system works. Second, the division into subcatchments makes it possible to package and sequence construction contracts to control expenditures over time (cash flow). Details on sewer layouts in each subcatchment are shown on Figure 3-25 through Figure 3-41.

A summary of the proposed sewer pipe lengths per subcatchment is shown in Table 3-12.



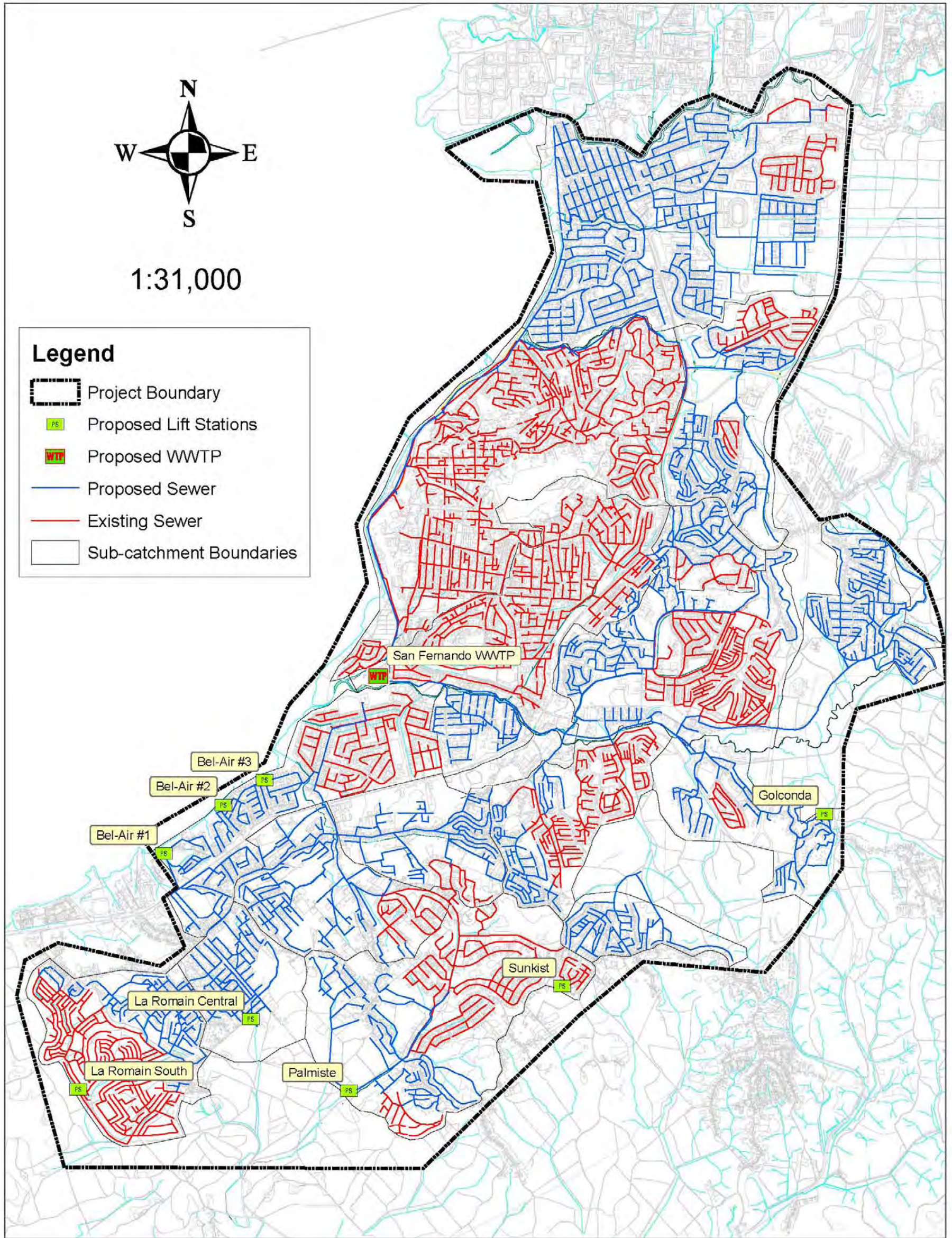


Figure 3-23 San Fernando Proposed New Collection System



Figure 3-24 San Fernando Collection System Subcatchments

**Table 3-12 New Collection System Pipe Length by Subcatchment**

Subcatchment	Pipe Length (km)
Marabella	48
Tarouba-Cocoyea	16
Cocoyea South	7
Pleasantville-Corinth	16
Vistabella-Gulf	6
San Fernando South	4
Ste. Madeleine	18
Bel Air - Gulf View	13
Green Acres	6
Duncan Village	11
Union Hall	8
Retrench-Golconda	11
La Romain North	15
La Romain Central	11
La Romain South	11
Palmiste South	13
Picton	9
<b>Total New Sewer</b>	<b>224</b>

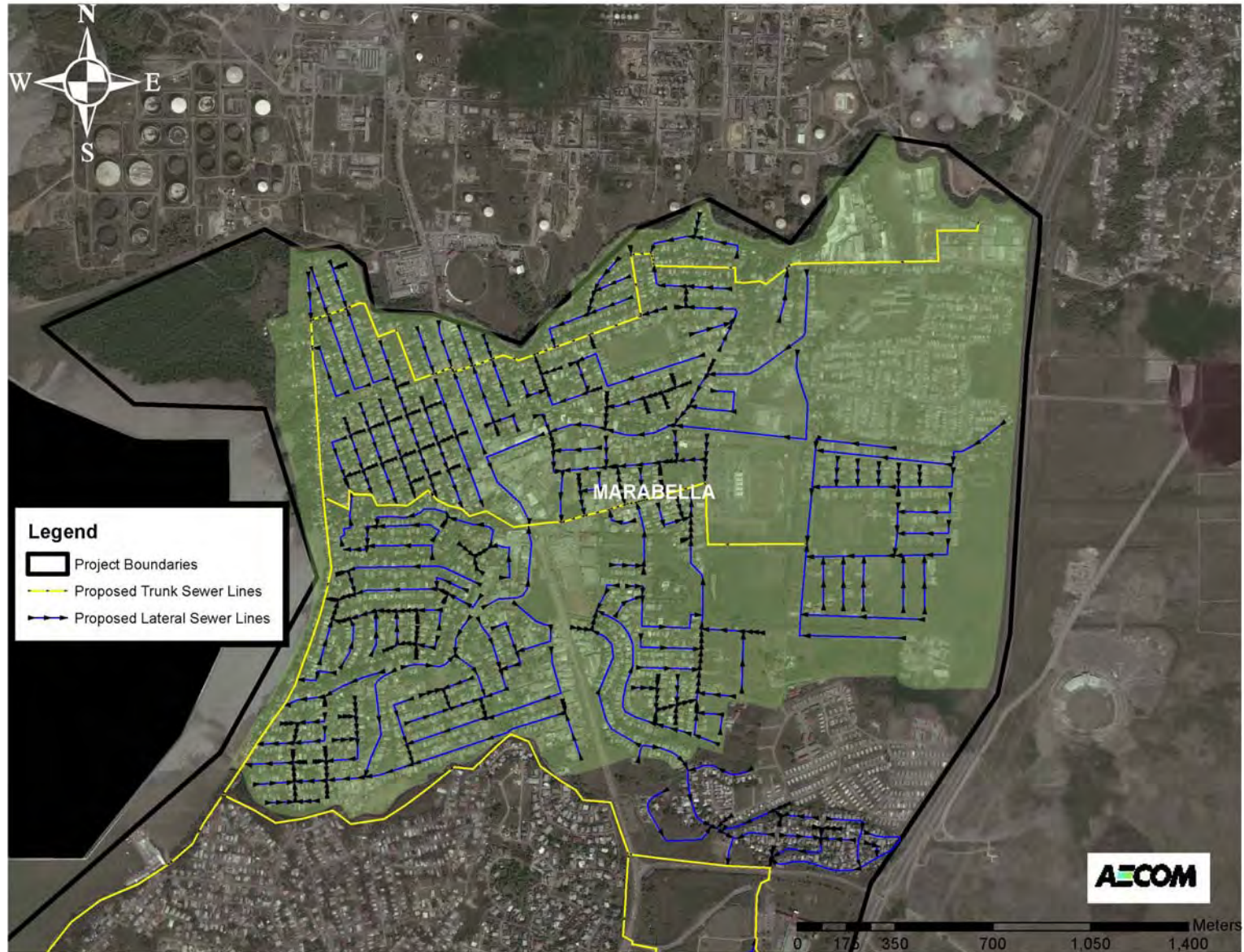


Figure 3-25 Marabella Subcatchment New Sewer Layout

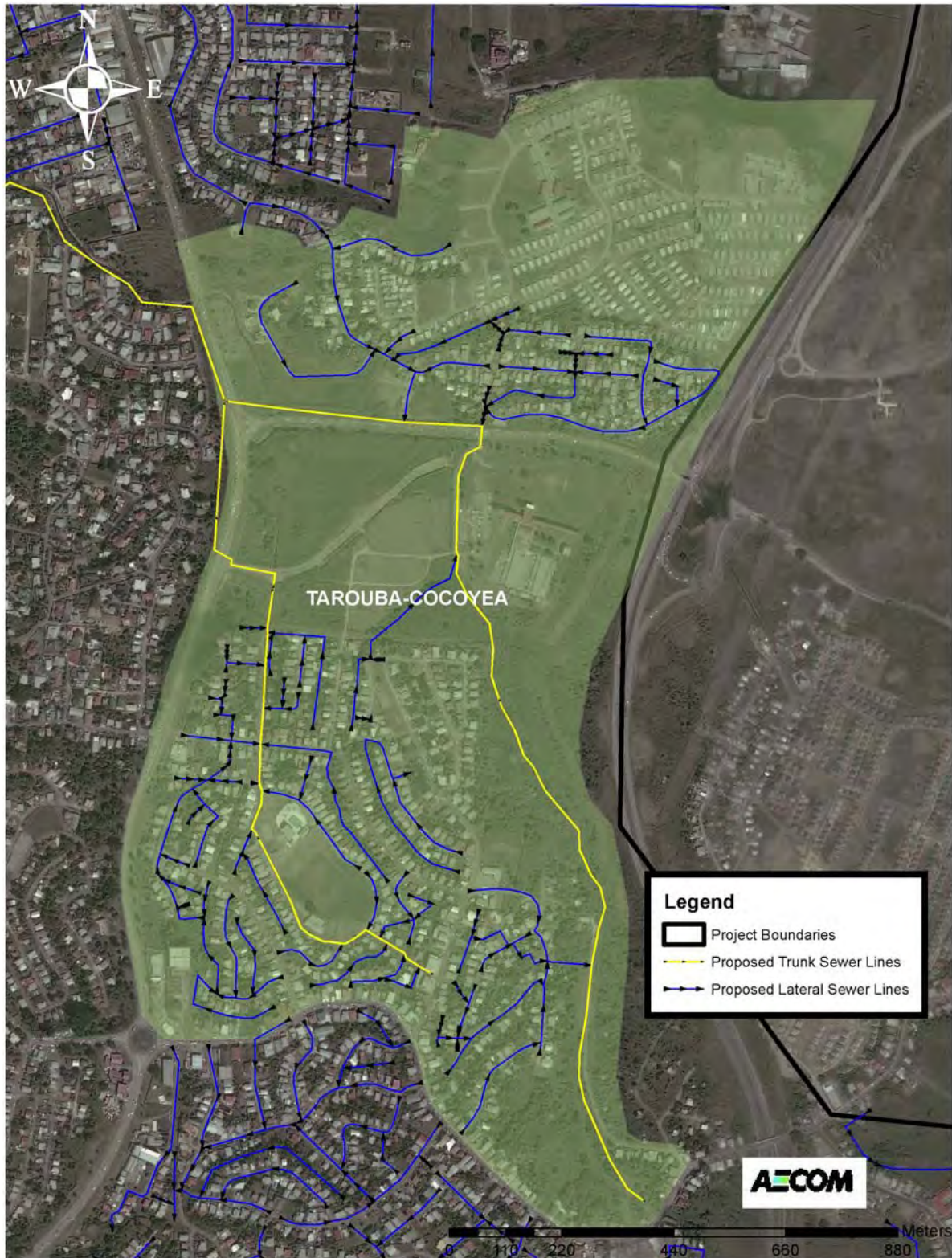


Figure 3-26 Tarouba-Cocoyea Subcatchment New Sewer Layout

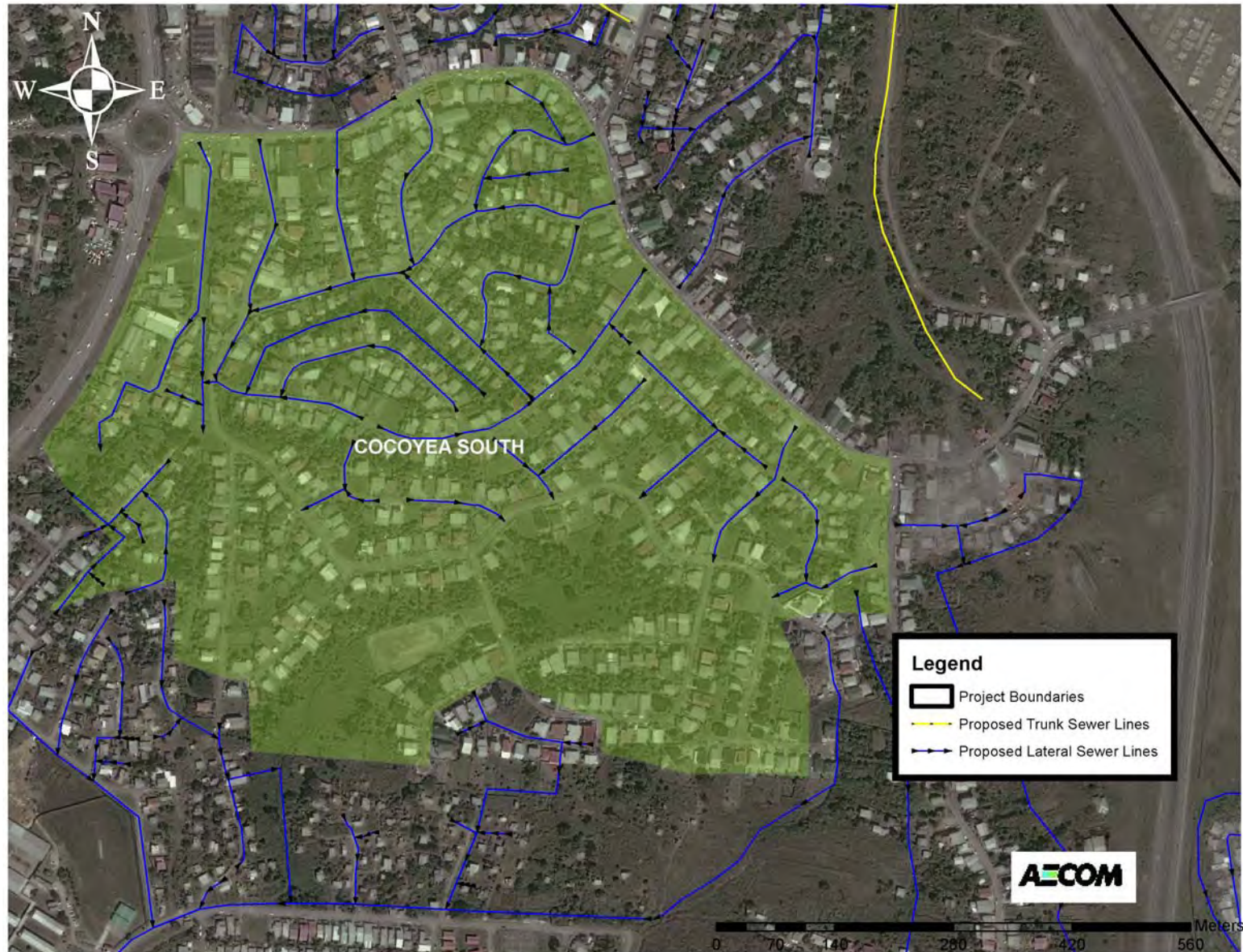


Figure 3-27 Cocoyea South Subcatchment New Sewer Layout

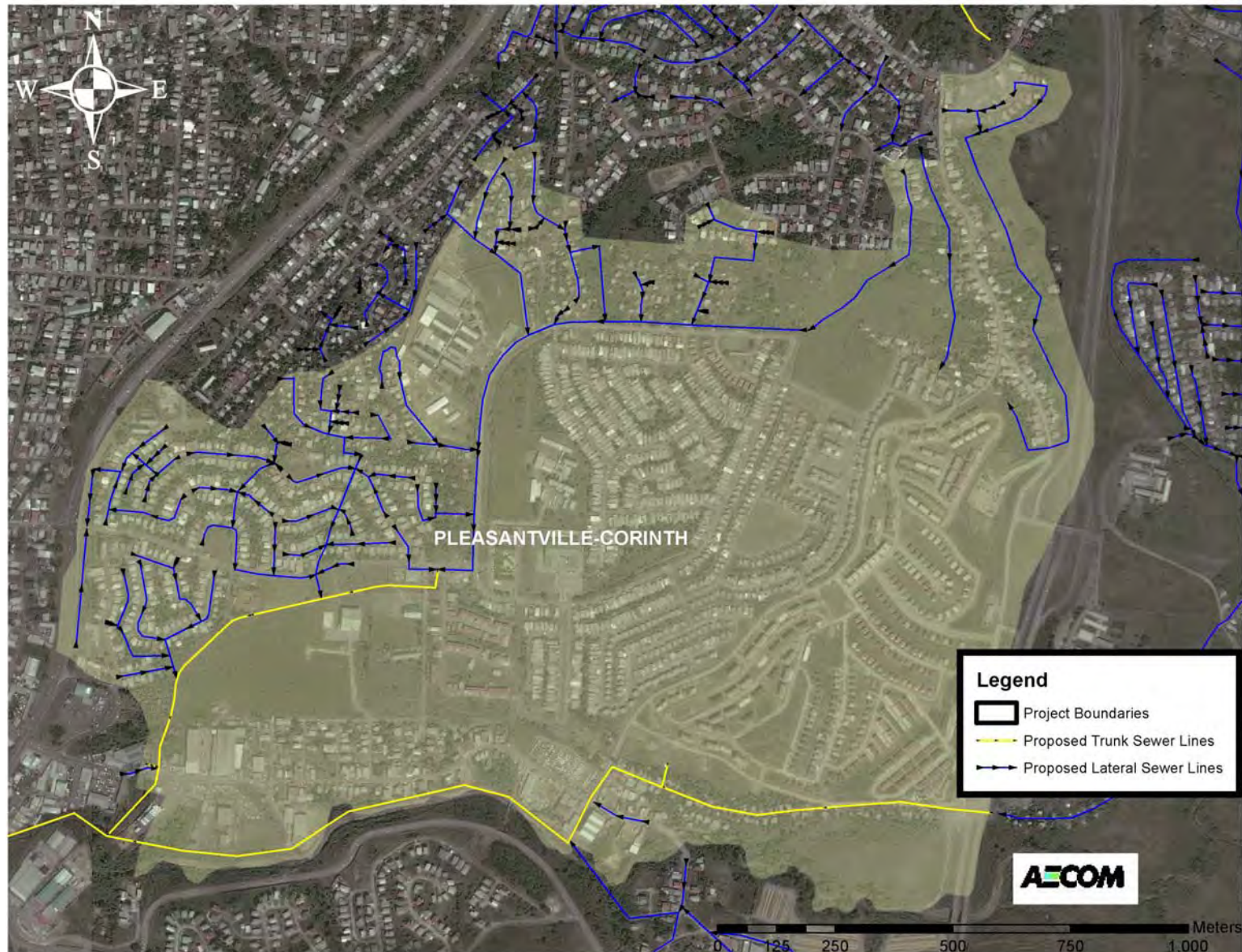


Figure 3-28 Pleasantville-Corinth Subcatchment New Sewer Layout



Figure 3-29 Vistabella-Gulf Subcatchment New Sewer Layout



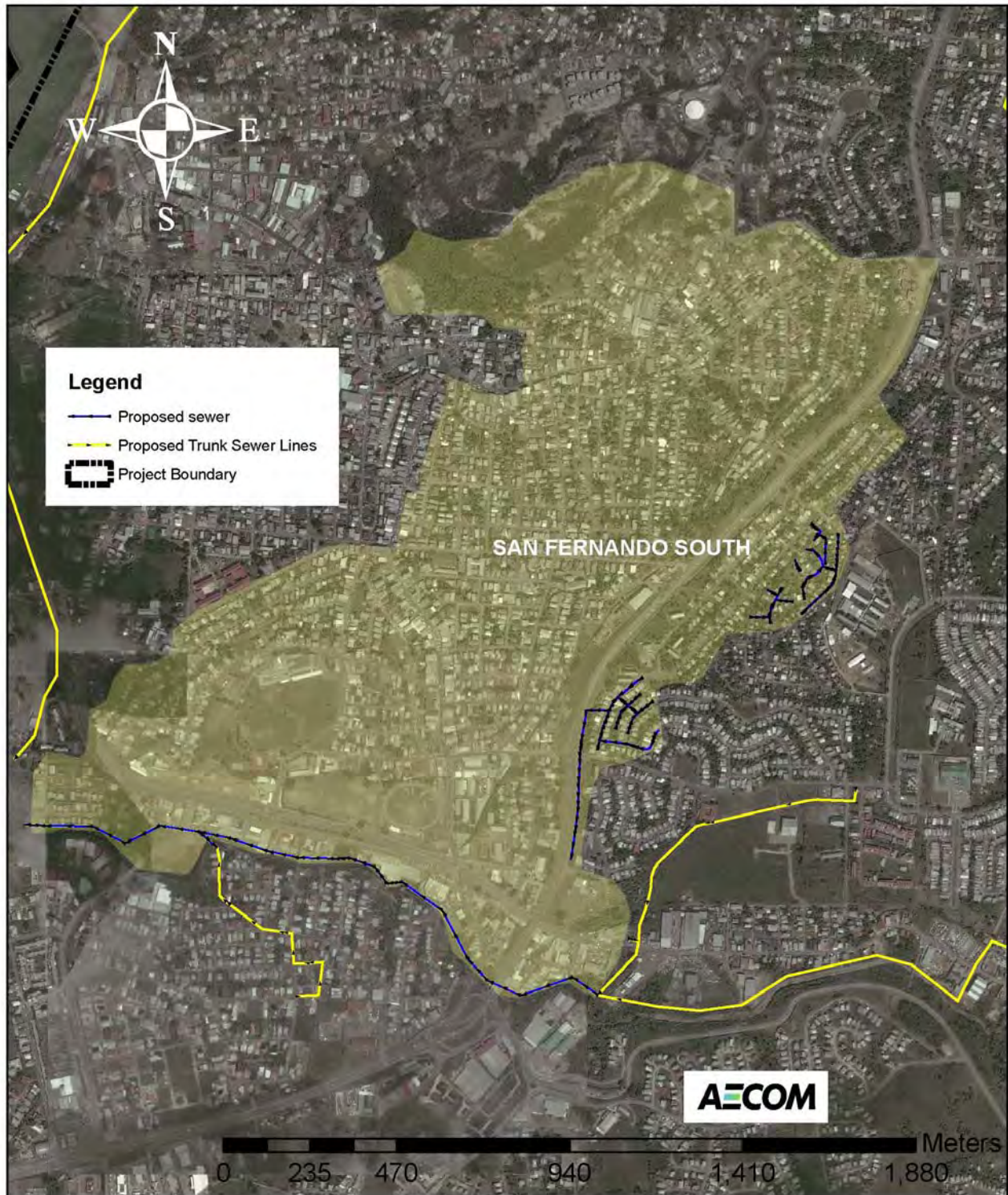


Figure 3-30 San Fernando South Subcatchment New Sewer Layout

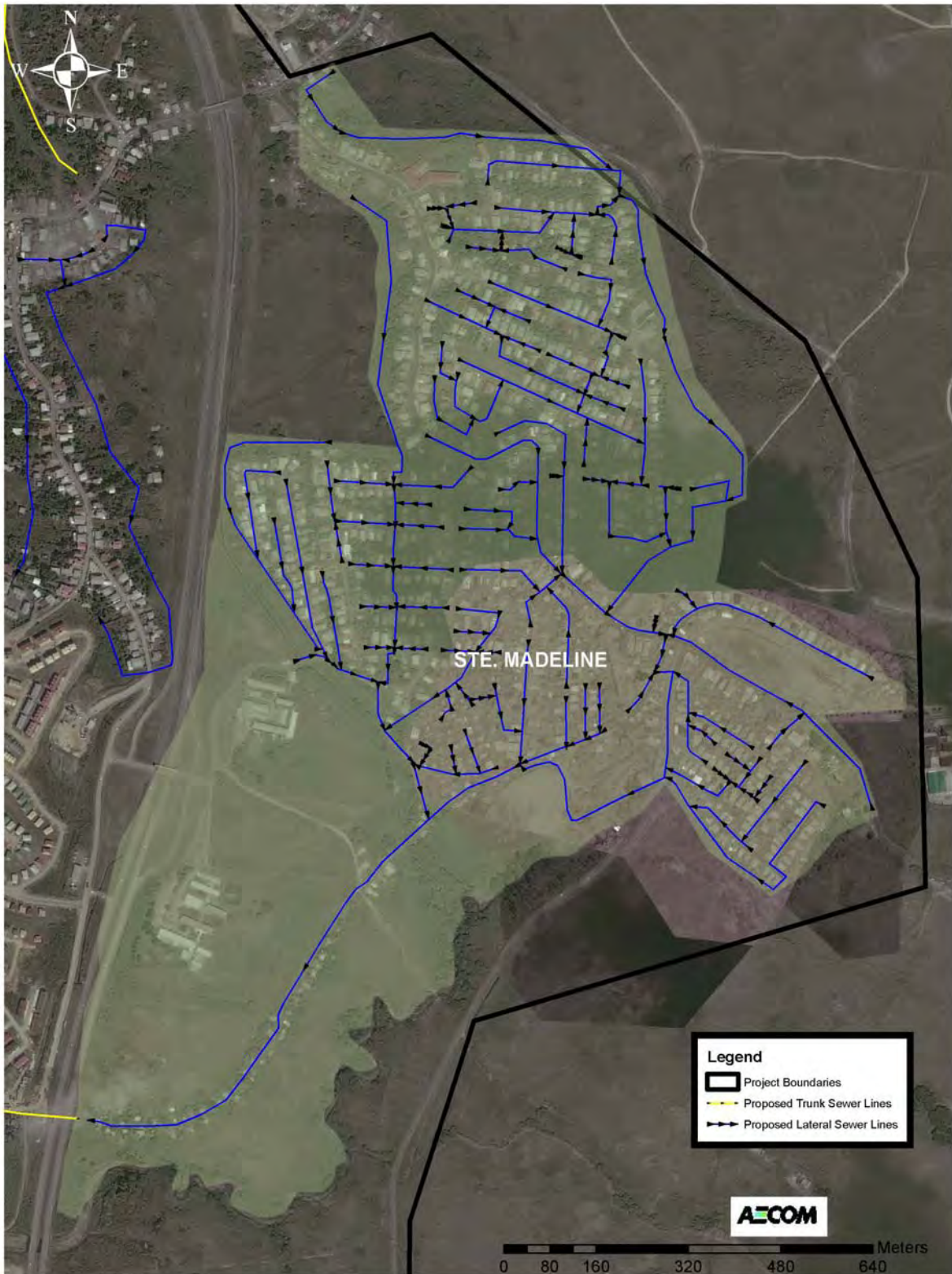


Figure 3-31 Ste. Madeline Subcatchment New Sewer Layout



Figure 3-32 Bel Air-Gulf View Subcatchment New Sewer Layout



Figure 3-33 Green Acres Subcatchment New Sewer Layout



Figure 3-34 Duncan Village Subcatchment New Sewer Layout

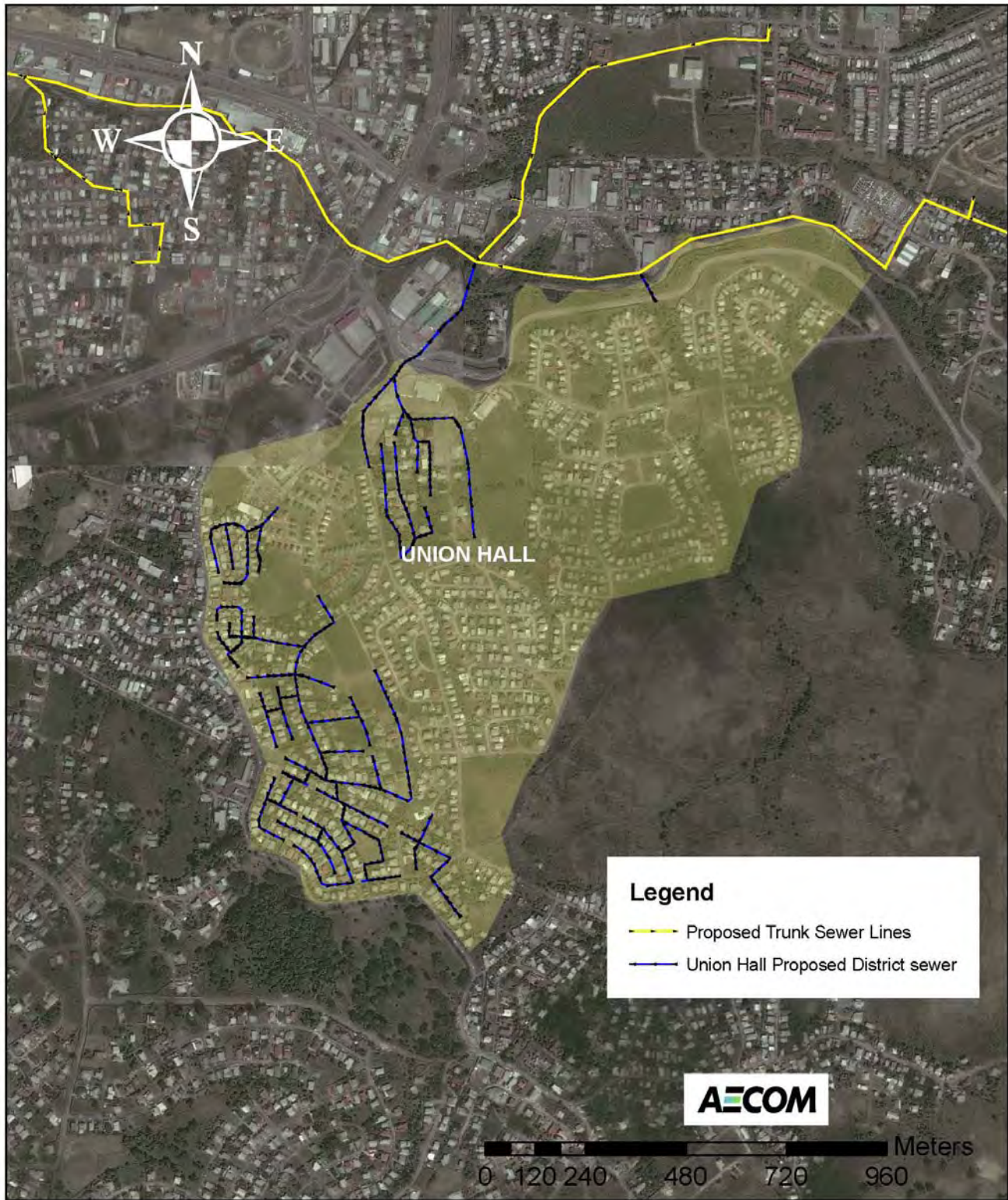


Figure 3-35 Union Hall Subcatchment New Sewer Layout

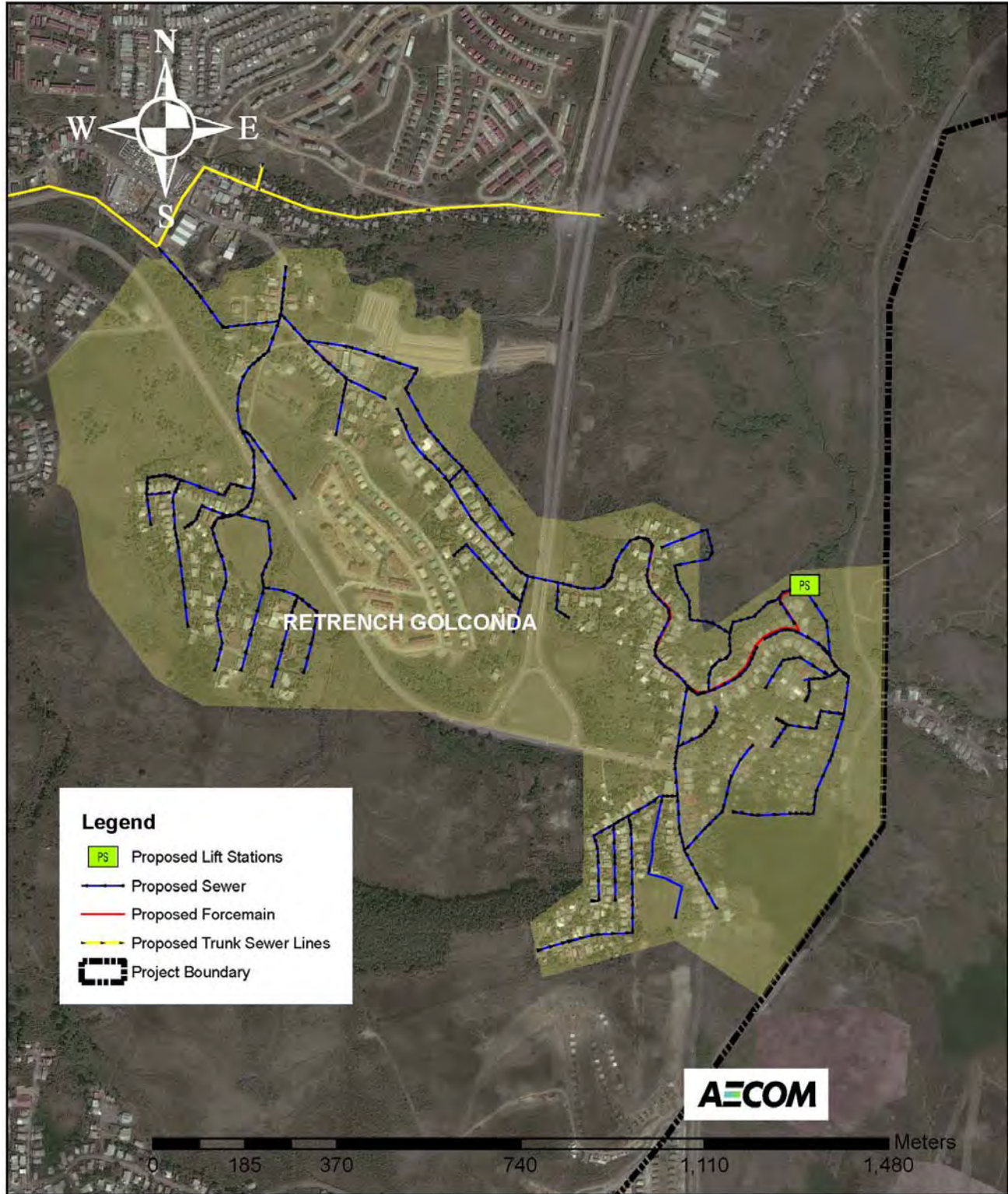


Figure 3-36 Retrench Golconda Subcatchment New Sewer Layout



Figure 3-37 La Romain North Subcatchment New Sewer Layout





Figure 3-38 La Romain Central Subcatchment New Sewer Layout

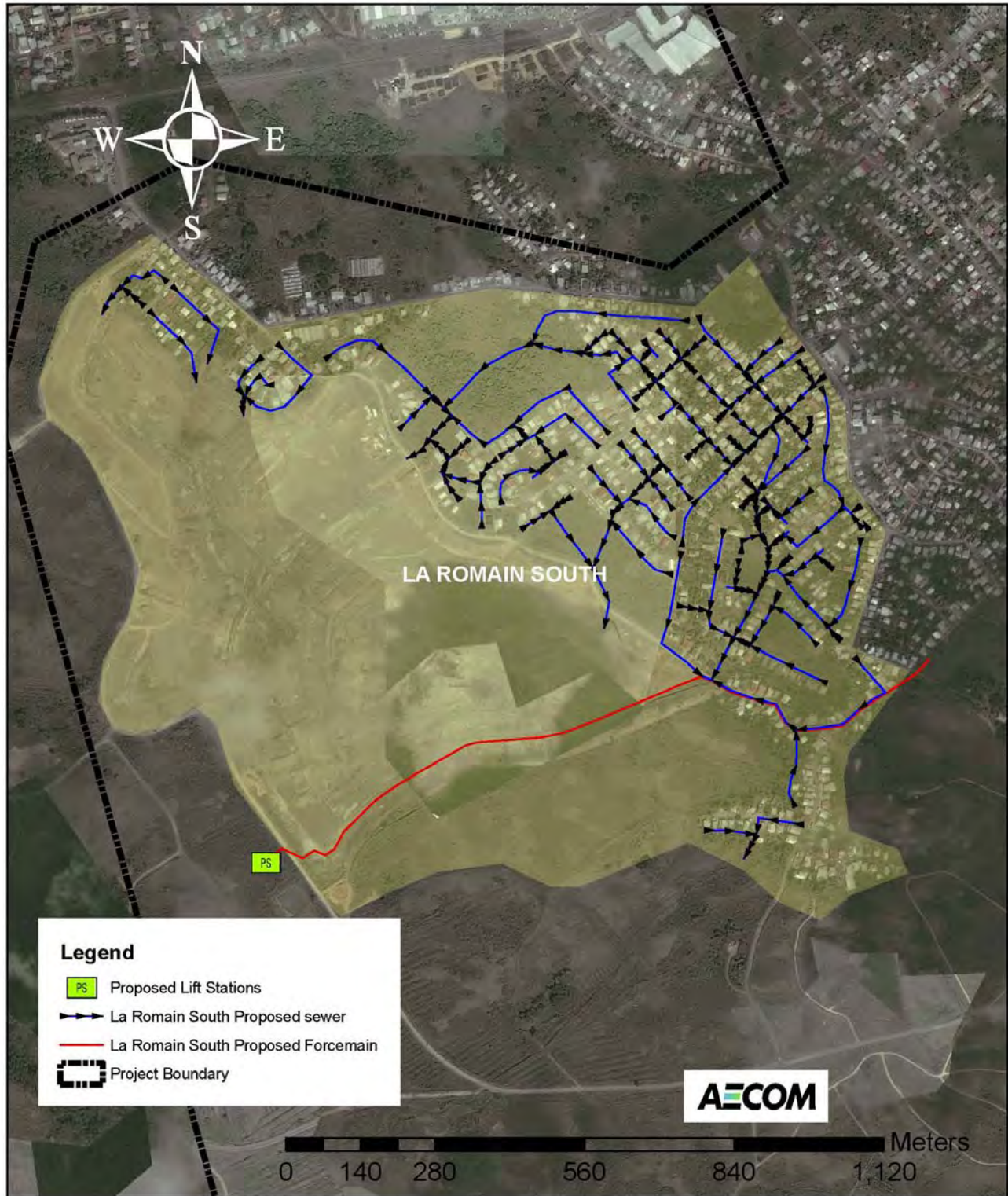


Figure 3-39 La Romain South Subcatchment New Sewer Layout

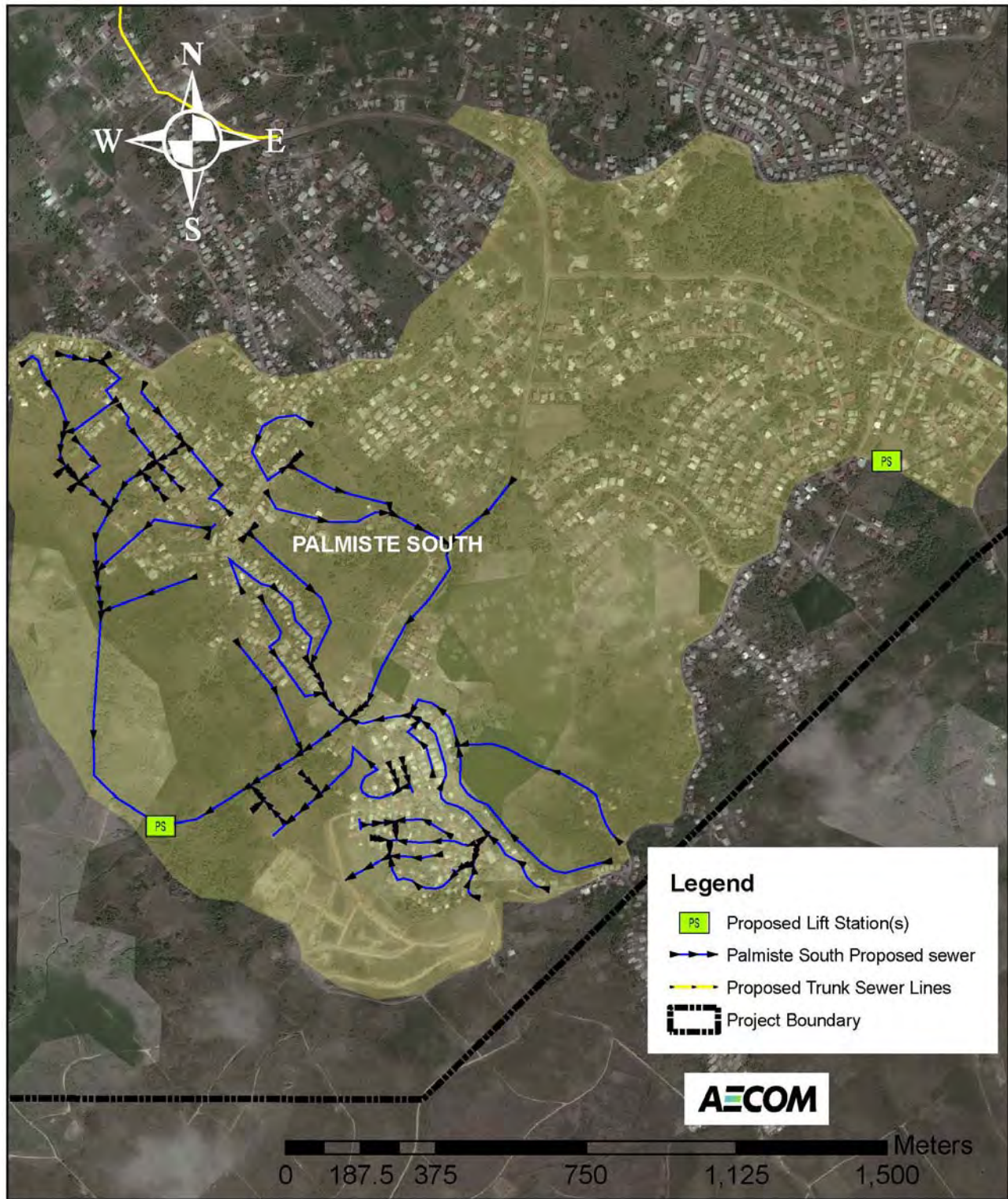


Figure 3-40 Palmiste South Subcatchment New Sewer Layout

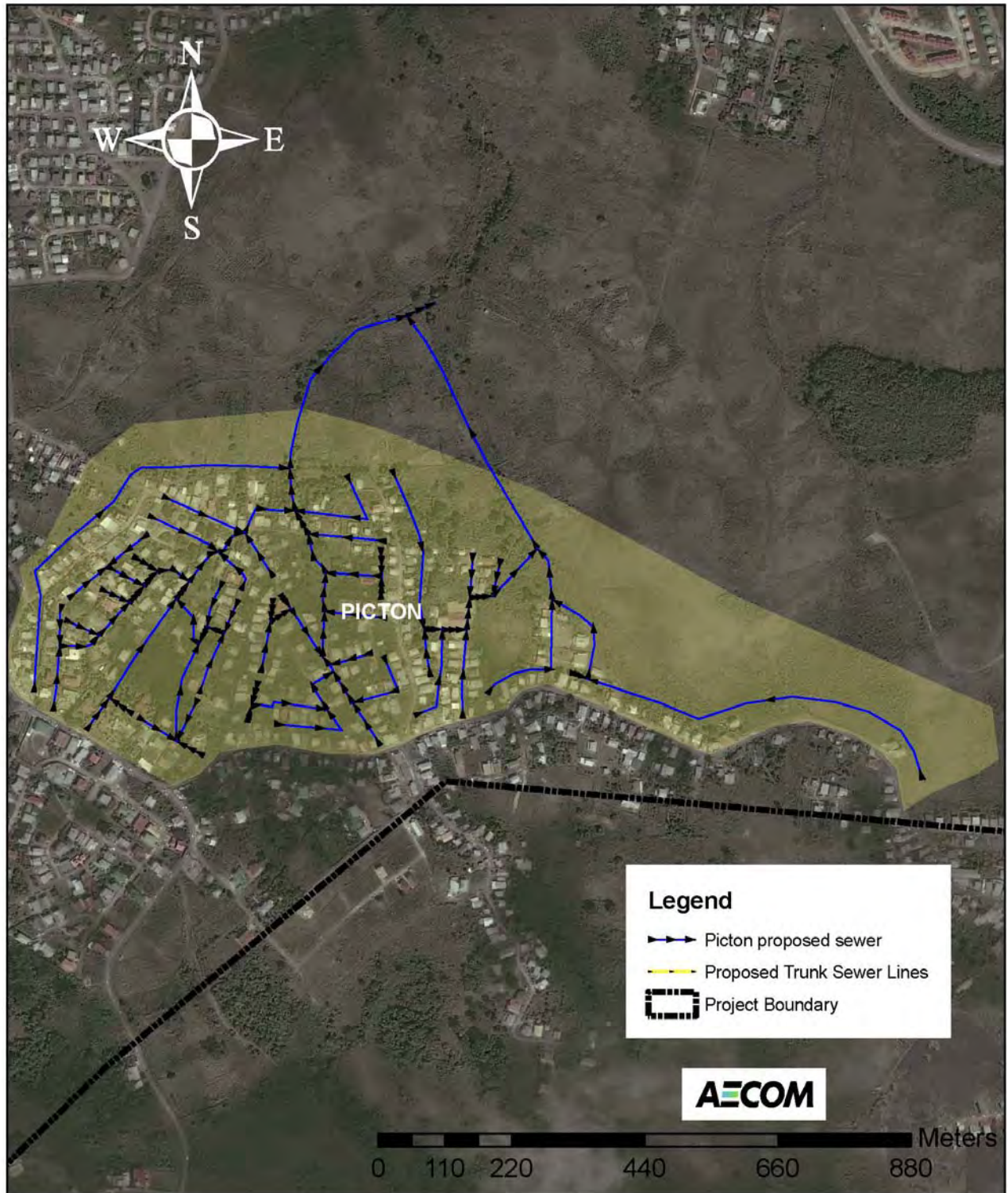


Figure 3-41 Picton Subcatchment New Sewer Layout



### 3.11 Wastewater Lift Stations

Wastewater lift stations are typically required when the depths of the sewers become so deep that construction costs become excessive and the resulting sewers are difficult to maintain. Lift stations are also relatively high capital cost installations, and they impose an annual operating and maintenance cost for pumping and upkeep. Since mechanical and electrical components can fail, lift stations reduce the reliability of the wastewater collection system. One of the key design objectives was to minimize the number of lift stations within the project area.

All existing lift stations in the project area will be eliminated, and replaced with gravity sewer. All abandoned lift stations will be demolished once construction of the new collection system is in operation and the stations are no longer needed.

Eight new lift stations are needed to pump wastewater collected in the southern subcatchments, which are situated south of a ridge line running east-west between San Fernando and Palmiste (Figure 3-23). These lift stations have been categorized by flow into three types. Type 1 stations handle flows less than 20 L/s, Type 2 stations handle flow greater than 20 L/s up to 150 L/s, and Type 3 stations handle flows greater than 150 L/s. Table 3-13 lists the eight lift stations along with the design PWWF capacity and the designated type. **Appendix C.3** has examples of drawings for all three lift station types.

**Table 3-13 Lift Station Information**

Lift Station	Design Flow (PWWF)		Type
	m <sup>3</sup> /day	L/s	
La Romain South	12,325	143	2
La Romain Central	17,542	203	3
Bel Air #1	1,507	17	1
Bel Air #2	1,871	22	2
Bel Air #3	2,482	29	2
Palmiste #1	605	7	1
Palmiste #2	7,842	91	2
Retrench-Golconda	1,505	17	1

### 3.12 Pre-Construction Activities

#### 3.12.1 Land Acquisition

The land used for the San Fernando WWTP is currently owned by WASA. WASA also owns a relatively large parcel of land south of the existing WWTP site and the Ciperio River. The southern parcel will be used for the new access road into the WWTP and for construction lay down and staging.

Locations of the new lift stations have been selected to avoid disruption to existing land use by placing the facilities on the site of an existing lift station or WWTP, or on a parcel that is currently



undeveloped (Table 3-14). Transfer or purchase of these lands for the purpose of constructing new lift stations is being pursued by WASA.

**Table 3-14 Lift Station Location Descriptions**

Lift Station	Location
La Romain South	Site of proposed WWTP for the new La Romain housing development
La Romain Central	Empty lot
Bel Air #1	Empty lot
Bel Air #2	Empty lot
Bel-Air #3	Small area on edge of park
Palmiste #1	Site of existing (non-functional) Palmiste WWTP
Palmiste #2	Site of existing (non-functional) Sunkist WWTP
Retrench-Golconda	Empty lot

While the majority of the new sewers will be constructed in public roadways, several sewer alignments will be located off-road. For these alignments it will be necessary for the construction contractor to obtain construction easements, and for WASA to obtain permanent easements for maintenance purposes. WASA is pursuing the necessary permanent easements for maintenance purposes.

### 3.13 Construction Phase

#### 3.13.1 Project Phasing

The San Fernando project will most likely be constructed in phases to accommodate operation of existing facilities, and minimize disruption in the community, while achieving a cash flow that will be affordable. The primary objective is to achieve maximum benefit during the first phase of construction by building the new WWTP and connecting areas with existing sewers to the new plant.

The proposed Phase I would consist of two construction contracts as follows:

- Contract No. 1 – New San Fernando WWTP.
- Contract No. 2 – Trunk sewers constructed using trenchless techniques plus connecting sewers between existing sewer areas and the new trunk lines. Elements of this contract would include:
  - Gulf trunk sewer from Marabella to the WWTP.
  - Ciper trunk sewer from Solomon Hochoy Highway to the WWTP.
  - Vistabella trunk from San Fernando Bypass Road to Gulf trunk sewer.
  - Connecting sewers to tie in the following sewer areas:
    - San Fernando
    - Pleasantville
    - Corinth HDC development



- Union Hall
- Parts of Tarouba and Cocoyea

**Table 3-15 Phase I of Subcatchment Construction Information**

Subcatchment	2035 PE	New Sewer Length, km	Comments
Marabella	0	2.9	Trunk line to be constructed under Trenchless Contract
Vistabella-Gulf	15,190	5.1	Trunk line to be constructed under Trenchless Contract
Tarouba-Cocoyea	2,120	2.2	Tie into Tarouba North and Tarouba Hts. lift stations and Westpark WWTP
San Fernando South	8,275	1.8	Trunk line to be constructed under Trenchless Contract
Pleasantville Corinth	6,040	3.1	Connection to existing Pleasantville lift station
Bel-Air Gulf View	4,230	0.2	Tie into existing Gulf View WWTP
Green Acres	0	0.1	Trunk line to be constructed under Trenchless Contract
Union Hall	4,180	0.7	Connection to existing Union 1 & 2 lift stations

Graphically, Phase I is seen in Figure 3-42.

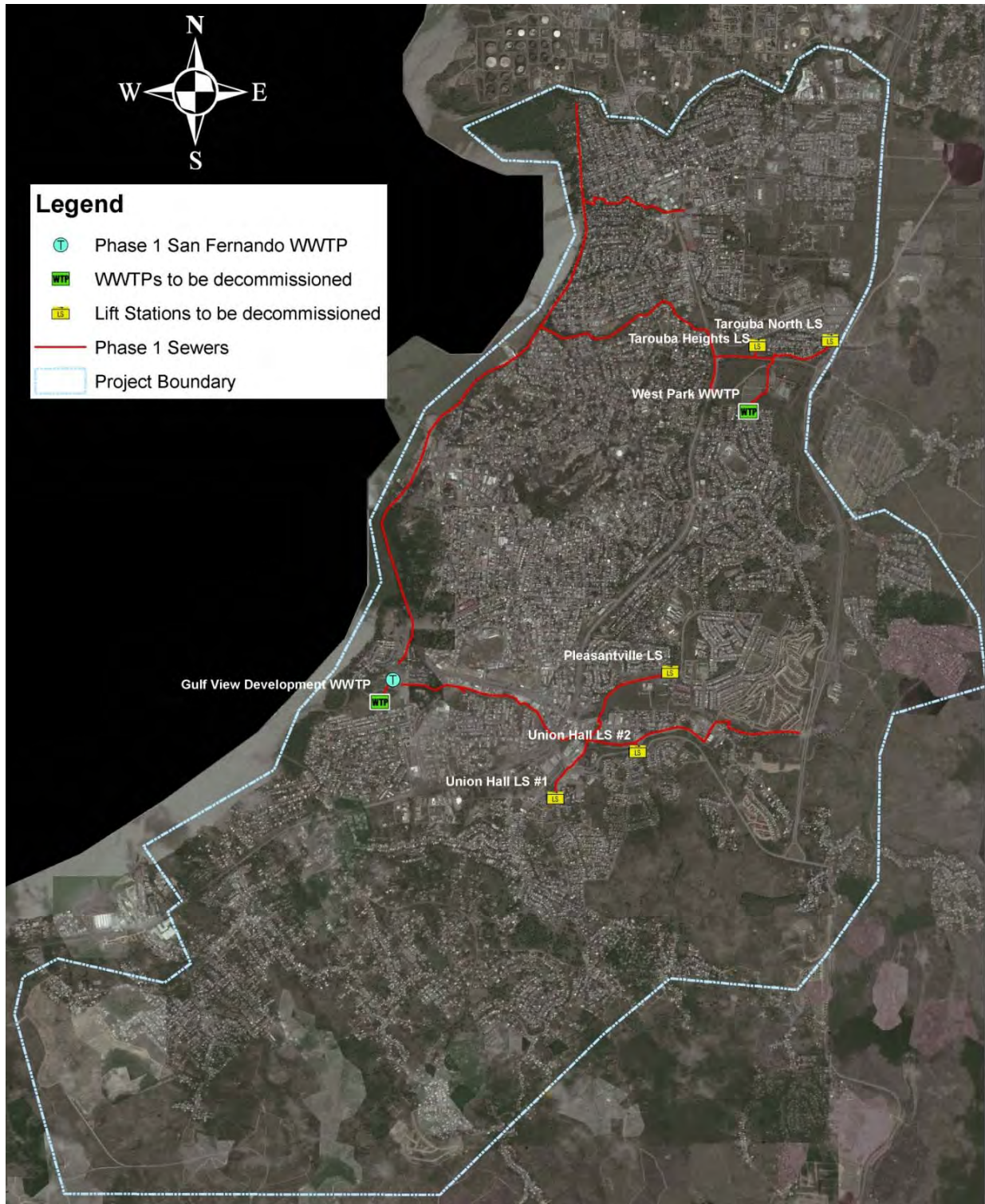


Figure 3-42 Construction Phasing, Phase I





At completion of Phase I, wastewater entering the existing San Fernando sewer system and most of the sewer areas that naturally drain to the Ciperó River would be treated in the new WWTP. The initial ADWF to the plant would be approximately 16 ML/d, which is 36 percent of the ultimate design ADWF of 45 ML/d. This equates to a service population of 40,035 pe out of 111,600 pe (2035 design year).

Additional phases would consist of one or more sewer construction contracts depending on the available funding. The number one priority would be to construct the trunk sewer from the WWTP, through the Gulf View residential area to Dumfries Road, and south along Dumfries Road to Palmiste Avenue. Completion of this trunk sewer would provide conveyance capacity to connect all the subcatchments located in the southern most portion of the project. Table 3-16 below lists the subcatchments that would be included in later construction phases. Priorities would be assigned based on several factors including connection of existing sewer areas, e.g., Palmiste South; environmental issues such as anticipated water quality improvement; and construction costs.

**Table 3-16 Additional Phases of Subcatchment Construction Information**

Subcatchment	2035 PE	New Sewer Length, km	Comments
Marabella	16,450	45.1	Small area sewerred; decommission Harmony Hall WWTP
Tarouba-Cocoyea	3,910	13.8	Mixture of sewerred and unsewerred areas
Cocoyea South	3,250	7.0	Includes remediation of Scotland Drive sewers
San Fernando South	435	2.2	Sewers from Scotland Drive, Blitz Village and Chaconia North connected to existing San Fernando sewer network
Pleasantville Corinth	5,130	12.9	Mixture of sewerred and unsewerred areas
Ste Madeline	4,000	18	Densely populated unsewerred area drains into Ciperó River
Bel-Air Gulf View	2,090	12.8	Densely populated area adjacent to Gulf
Duncan Village	3,660	11	Mixture of sewerred and unsewerred areas; enable elimination of 2 lift stations in Palmiste (Pollonais 1&2)
Green Acres	1,320	5.9	Densely populated unsewerred area
Union Hall	3,390	7.3	Existing sewers connected as part of Phase I
Retrench Golconda	3,360	11	North section drains to Ciperó River; south section drains south
Palmiste South	6,140	13	Mixture of sewerred and unsewerred areas; enable elimination of Palmiste WWTP and Kelvin Rd. lift station
La Romain North	3,520	15	Enables elimination of Palmiste Blvd. lift station
La Romain Central	3,730	11	
La Romain South	9,570	11	Enables elimination of proposed La Romain EMBD WWTP
Picton	1,610	9	Cost per sewerred property high due to remoteness from trunk sewer



### 3.13.2 Sewer Location and Alignment

Generally sanitary sewers are in locations accessible to each property facing a roadway. Sanitary sewers will be installed along roadways where possible, and generally be located at an offset of 1.5 m from centerline of the roadway. While it is common practice to locate sewers and other utilities offset from the centerline of the roadway so that when maintenance such as sewer cleaning is conducted, one lane of traffic can be maintained, the final location is dictated by other factors such as location of existing utilities, road width, and elevation of buildings relative to road elevation. In cases where sanitary sewers cannot be located along roadways, a sewer easement will be required. The requirement for easements will be minimized to the degree possible by keeping sewers within the road right of way as much as possible; however, for properties in low lying areas and not located near roadways, an easement is unavoidable. Manholes must be located in accessible areas of the roadway or easement for maintenance purposes.

### 3.13.3 Crossing Clearance to Sewers

It is essential that all pipeline crossings be inventoried as they affect both the alignment and profile of the sewer network. The plan-profile drawings will show the existing utilities and new sewers that cross will be located at the required separations to meet utility requirements. The National Gas Company (NGC) natural gas pipelines are of particular importance and require a minimum separation of 0.9 m where crossings have been identified. When crossing over or under watermains of 450 mm in diameter or less, a minimum clearance of 0.15 m is required. This is the minimum to be used only when spatial constraints exist. In normal situations, a minimum of 0.3 m clearance will be provided. Watermains larger than 450 mm diameter require a minimum clearance of 0.6 m. A minimum clearance of 0.23 m is required for storm sewers/ drains. Also, the minimum horizontal separation recommended between watermains and sewers is 2.5 m. For buried power lines (T&TEC), a minimum spacing of 0.5 m will be maintained. For telecommunication lines (TSTT), a minimum spacing of 0.3 m will be maintained.

### 3.13.4 Pipe Bedding, Backfill and Reinstatement

Locally sourced granular bedding material is recommended for sewer pipe and manhole installation as it will be readily available and at a reasonable cost. Sewer pipe should be placed on a minimum of 150 mm of bedding sand and 300 mm of cover above the pipe crown.

Sand bedding will be used for sewers installed above the water table. For sewers below the water table, a free draining granular bedding material will be used. A variety of backfill materials will be specified depending class of roadway, location of water table, and type of pipe material. It is anticipated that excavated material can be used as common backfill for sewers off roadways and as select backfill under roadways if it meets the specification requirements for material composition, strength, compaction and gradation. This will be determined through testing by the contractor. The backfill material must be compacted in 300 mm layers using mechanical compaction equipment to meet compaction specifications stipulated in the contract documents. For all roadways compaction is to be 95% of modified proctor in accordance with ASTM D698. Key standard details for trench backfill in wet and dry conditions are included in **Appendix C.4**.

Roadways will be reinstated after trenches have been backfilled. Most roadways in the project area are asphalt surface. The thickness of asphalt, base course and sub-base materials will depend on the classification of roadways, which is based on vehicular traffic. Class 1 roadways are main roads, Class



2 roadways are secondary paved roads, and Class 3 roadways are gravel roads. Key standard details for road reinstatement are included in **Appendix C.4**.

### 3.13.5 Sewer Installation Techniques

Various techniques were evaluated for installation of the sewer lines within the project area. Factors affecting the installation include:

- Traffic disruption and disruption to the general public and adjacent property owners
- Interference with existing utilities
- Soil conditions
- Cost

Soil conditions that affect sewer construction methods and cost the most include existence of rock, groundwater levels, and variability in soil conditions. The existing buried infrastructure also has a major impact on both the selection of construction technique and the risks associated with its use.

The most common installation method for sanitary sewer piping is conventional open cut trenching. It is usually the most economical alternative when installing pipe at relatively shallow depths, especially in suburban or rural areas. In developed urban areas the extent of disruption and impact to the area from construction activities is more significant with open cut trenching. Where sewers are deeper, stability of side slopes can pose a problem depending on soil conditions. Trench cages and shoring must be used to protect workers and reduce slope destabilization. Where installation is below the water table, trench dewatering is required which can add significantly to the cost. Existing utility crossings need to be accommodated and repaired if damaged. The selection of the alignment is extremely important to minimize conflicts with existing utilities, minimize disruption and reduce restoration costs.

In highly developed areas with existing underground infrastructure present, trenchless installation techniques are often justified. The capital cost of trenchless techniques including pipe jacking, microtunnelling, and horizontal directional drilling (HDD) are higher than conventional open cut trenching but may be justified when the direct and indirect social costs of disruption to the public are considered. For microtunnelling and pipejacking, shafts ranging in size from 3-6 m diameter are dug and spaced along the route. These shafts affect a smaller portion of land when compared to the open cut construction methods.

For San Fernando, trenchless techniques (microtunnelling/ pipejacking) have been included in the design for the trunk sewers along the Gulf Coast, Marabella River, Vistabella River, and Ciperio River. These Trunk sewers are deep, below the water table, in congested areas, and range in diameter from 750 mm to 1500 mm. The shaft locations along the trunk lines where the trenchless technology will be used in the design are seen in Figure 3-43.

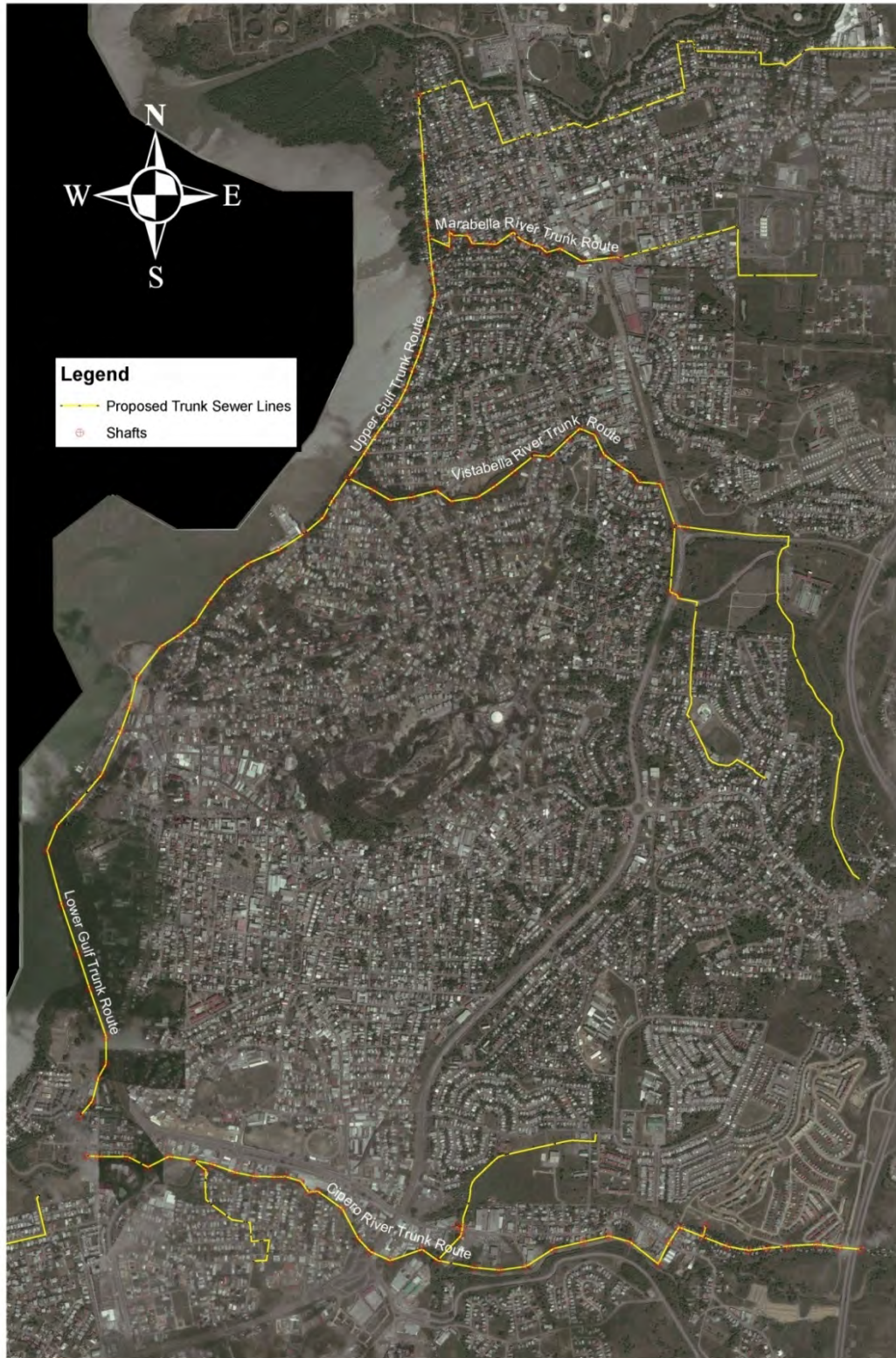


Figure 3-43 Trunk Sewer and Shaft Locations



### 3.13.6 Site Grading and Drainage

In all instances, surface runoff will be directed away from buildings to the site perimeter where it will be collected in a series of box drains and ditches that connect to the drainage channels in the area. Internal drainage swales/ditches will be designed as required to carry runoff to the appropriate drainage channel. All roadways will be crowned and elevated as required above existing ground to provide positive drainage to adjacent ditches to ensure the pavement structure remains in an unsaturated condition. Roadway profiles will be coordinated with building elevations at delivery points to maintain the appropriate elevation of vehicles in relation to the facility they are accessing. Roadway profiles will also be coordinated with piping layouts to ensure adequate clearance between pavement structures, ditch inverts and pipes.

### 3.13.7 Erosion Control

Erosion control measures will be considered along sections of sewer adjacent to river and stream beds and where the sewer crosses a river, stream and major drain. Erosion control blankets, rip rap, and concrete encasement will be utilized to ensure that erosion of pipe support materials does not occur during the rainy season. Erosion control during construction and other environmental protection requirements are covered in the project technical specifications, specifically Environmental and Aesthetic Protection, and Erosion Protection, which are included in **Appendix C.5**.

### 3.13.8 Traffic to Site

Traffic to the San Fernando WWTP Site will vary throughout the 24 month construction period. Estimations of traffic based on vehicle types are below:

- Worker Vehicles - Daily car/ light truck traffic will occur from 7am-5pm daily and range from:
  - 15 vehicles in months 1 to 5.
  - 40 vehicles in months 7 to 24.
- Lowboy Semi Trailers – Divided into construction equipment and structural piles:
  - Cranes, excavators, backhoes and other equipment will be brought to the site during months 1-16.
  - Piles - Within the first 12 months of construction, 2 vehicles per day for up to 4 months.
- Dump Trucks – Within the first 12 months of construction, 20 trips per day for up to 3 months.
- Concrete Trucks – In months 7-16 of construction, an estimated 1600 trips will be made to the WWTP site, usually in groups of 16 trips per pour of concrete.
- Flat bed semi-trailers – In months 14-24 equipment will be brought to the WWTP site, by up to 60 trips.

As the majority of the collection system will be constructed in road right-of-ways, construction will impact traffic throughout the project area. The impact on traffic and the mitigating measures are discussed in further sections of this report.



### 3.14 Operation of San Fernando Wastewater System

#### 3.14.1 Labour Requirements

The anticipated on-site staff needed to operate and maintain the new WWTP is as follows:

Managerial	3
Administrative support	2
Operations	6
Laboratory	2
Maintenance	5
<hr/>	
Total	18

The WWTP administration building will house the offices for the managerial and administrative staff. In addition, an office will be provided for the laboratory supervisor and two offices for chief operator and visitors. A locker and change room intended for the managerial and administrative staff will include lockers, showers, and washrooms. In addition, two separate washrooms will be provided for staff and visitors' use. A lunchroom with a refrigerator, microwave oven and a sink will be provided.

The WWTP utility building will have an office area for maintenance staff, lockers, showers, and change-room for the operations and maintenance staff as well as a lunchroom, washrooms and a laundry for the cleaning of clothing.

Additional staff will be required for maintenance of the collection system and lift stations. The anticipated field staff will include two crews each comprising a crew chief and two labourers. Their office base will be near the WWTP, possibly in a future facility located on the WASA land south of the Ciperio River.

#### 3.14.2 Treatment Plant Process Control

The WWTP will be using the activated sludge process to convert colloidal and soluble contaminants into settleable solids that can be removed in gravity settling basins. The conversion is achieved by bacteria that use carbonaceous compounds for food and produce more biomass. This process is controlled by making sure the bacteria have the right environment (balance of food, oxygen and other nutrients) to perform effectively. Secondary effluent from the settling basins will be filtered and disinfected to achieve reclaimed water quality. The activated sludge process produces excess biomass that must be removed from the process and stabilized.

Operators will monitor the treatment processes using permanently installed field instruments and portable measuring devices. Based on operating data, dissolved oxygen levels will be adjusted and the inventory of biomass in the reactors will be maintained at appropriate levels.

At the WWTP, waste activated sludge (WAS) removed from the activated process will be thickened, digested, and dewatered to cake form and hauled off site. Operators will need to make up batches of polymer used to condition the sludge ahead of the dewatering equipment and monitor the operation of the equipment while it is running.



Other treatment processes that require monitoring and some level of control to keep the overall treatment system operating optimally include:

- Fine screening.
- Grit removal.
- UV disinfection.
- Effluent filtration.

The treatment plant will be equipped with laboratory facilities fully equipped to conduct all necessary process control tests including chemical oxygen demand (COD), total suspended solids (TSS), and nitrogen compounds.

### 3.14.3 Instrumentation and Control

The WWTP will be staffed 24 hours per day, seven days per week (24/7) with at least one operating crew on duty at all times. This level of attendance is consistent with semi-automatic operation wherein provision for operator intervention will be provided. In a semi-automatic system, set point adjustment becomes the responsibility of the operators and some of the open-close and start-stop functions are manual. The duty crew will be trained and directed to make the necessary process modifications to optimize the treatment system on an ongoing basis.

Field instruments will be wired to a series of marshalling panels mounted in the electrical rooms. The main marshalling panel locations will be in the utility building control room and the sludge dewatering building electrical room. Adjacent control centres will receive the wiring from the marshalling panels into programmable logic controllers (PLCs). All control functions and monitoring of digital input and output will be through these PLC centres.

The control centres communicate through an Ethernet network connection, which further connects to a series of human-machine interface (HMI) devices and an archive computer. One HMI will be located at each control centre and in the control/ operations room in the Administration Building.

### 3.14.4 Waste Management

Measures that could be taken to minimize pollution caused by construction or its related activities are:

- Provide temporary sanitary facilities for workers.
- Provide regular servicing of temporary sanitary facility by septage truck, with disposal to a proper disposal facility.
- Install silt control fences along sewer trench construction, and around stockpiled materials.
- Require the contractor to provide a Construction Environmental Management Plan to address the collection and proper disposal of all unsuitable construction materials or refuse.
- Recycle all excavated materials where suitable.
- Provide a designated landfill site for disposal of surplus construction materials and/or contaminated soils, and monitor the usage of the site by the contractor.

Residual materials physically removed from the wastewater during treatment (screenings and grit) will be washed and dewatered before sending to landfill for disposal. The dried biomass, commonly known



as biosolids, is suitable for land application in accordance with the USEPA Class B Biosolids (with monitoring).

### 3.15 Demolition and Decommissioning of Existing Facilities

The establishment of a comprehensive wastewater collection system leading to a single WWTP involves the decommissioning and demolition of several wastewater treatment plants and lift stations in the project area. All operating facilities will remain in service until the new facilities are constructed and placed in service. The following activities are involved in the process and will be employed in the project area:

- Removal and salvage of electrical, instrumentation and associated devices, ventilation and air conditioning, plumbing and process and other mechanical equipment and piping as necessary.
- Rerouting and/or terminating utilities.
- Shutting off, capping and abandoning utilities and underground piping.
- Demolition and removal of structures
- Backfilling and securing wet wells, below grade tanks and open pits

Existing WWTPs and lift stations, that are not functional or are no longer needed once the new facilities are constructed, will be removed, demolished and backfilled. The known facilities in the project area are listed below. Their locations are shown on Figure 3-3.

- Corinth HDC LS
- Gulf View Development LS
- Harmony Hall LS
- Kelvin Avenue LS
- Palmiste Boulevard LS
- Pleasantville LS
- Pollonais Crescent #1 LS
- Pollonais Crescent #2 LS
- Retrench HDC (Hillcrest Gardens) LS
- Tarouba North LS
- Tarouba Heights LS
- Union Hall #1 LS
- Union Hall #2 LS
- San Fernando WWTP (some facilities will be re-used or left in place for future use)
- Gulf View Development WWTP
- Harmony Hall (eTeck) WWTP
- Marabella Secondary School WWTP
- Palmiste WWTP
- San Fernando Technical Institute WWTP
- Sunkist WWTP
- Westpark WWTP
- Corinth Housing Development Retention Pond





### 3.15.1 Demolition Process

Prior to demolition, removal or abandonment all earmarked structures will be released by WASA and all electrical, ventilation, process and plumbing services will be rerouted or shut off outside of the demolition area. Items identified for salvage will be delivered to a storage facility location specified by WASA. All other existing facilities intended to remain in-place that may be affected by the demolition process will be surveyed and recorded both before and after the demolition process. If necessary, any affected facility will be restored to its original condition. All existing facilities, utilities and equipment intended to remain will be maintained in service and protected from damage.

- Roadways, streets, walks and other facilities occupied or used by WASA and the public will not be closed or obstructed without permission from the relevant authorities.
- Relevant utility authorities will be notified prior to razing operations to allow for disconnection, removal or relocation of equipment serving existing facilities if necessary.
- Salvaged material and equipment to be retained shall be transported to a designated storage site. Materials to be salvaged include pumps, motors, standby generators, valves, hoists, fittings, and aluminum sheeting.

### 3.15.2 Demolition Operations

Demolition involves the removal of existing structures to a point below specified finish grade.

- Equipment and materials not scheduled to be salvaged will become property of Contractor and legally disposed of off-site.
- Wastewater and wastewater sludge from existing tanks will be drained via existing and newly constructed collection system, or if necessary, hauled to the San Fernando WWTP. Care will be taken so that all liquids are contained and properly treated.
- Demolition of existing structures will include superstructure, foundation, footings, piles, utility drains and other piping 450 mm below finished grade in landscaped areas, and 1 m below finished grade in pavement areas. Structures within influence zone of new structures will be completely demolished.
- Below grade structures that are abandoned in-place will have openings cut in the floors to provide for drainage.
- Utility drains and other piping will be plugged or capped.
- The site of the demolished structures will be graded to prevent ponding.

### 3.15.3 Removal Operations

These operations involve the removal of portions of existing structures or utilities to both above and below finish grade as required.

- Existing concrete, steel and masonry will be removed as required. Smooth, straight joint or cut line and cuts parallel with walls or floors will be employed. Cut and patch will be done in accordance with Contract specifications.
- Utilities and piping will be removed and plugged/ sealed permanently with steel cap, concrete plug or other approved method.



- Abandoned utilities and underground piping within influence zone of proposed underground piping and proposed structures will be removed.
- Temporary shoring and bracing will be provided in order to transfer loads of existing remaining construction from construction being removed where necessary.

### 3.15.4 Abandonment Operations

Abandonment is the removal of existing utilities from service, and involves full disconnection from other portions that are to remain in service. Portions of the utility that are being abandoned are removed from the influence zones of structures, manholes or underground piping, and piping ends are plugged or capped as necessary.

- Relevant underground utilities and piping will be selected for abandonment.
- Compatible caps for pressurized type piping will be provided. Thrust blocks for caps (unless piping has fully restrained joints) will be provided.
- Gravity type piping will be fitted with concrete plugs. Plugs will be thrust block standard concrete a minimum of 0.6 m thick.

### 3.15.5 Disposal

Sludge, debris, and other undesirable and unsalvageable material resulting from demolition operations will be disposed of to the nearest landfill site. Wastewater will be disposed of to the San Fernando wastewater treatment plant. All hazardous waste must be disposed of in accordance with the regulation and code requirements.

## 3.16 Demolition and Decommissioning of New San Fernando Wastewater Project

The project is designed for 2035 flows; however, the WWTP is likely to remain in service for many years beyond that date because the need for wastewater treatment will continue indefinitely. While equipment will need to be replaced over the course of time, concrete structures typically have a useful life in excess of 50 years. (The existing WWTP was constructed in the late 1960s and the concrete structures continue to meet their intended functions.) Future conditions that might affect the decommissioning decision are largely based on unknown factors; therefore, details of facility closure and decommissioning presented herein are limited. A decommissioning plan would be prepared in the future in the event that the plant or components of its infrastructure would be decommissioned.

Decommissioning of the wastewater treatment plant and its associated facilities would be executed in a manner consistent with relevant legislations and regulations at that time. This process would involve interaction with the jurisdictional regulatory agencies of Trinidad and Tobago. WASA would develop a detailed plan for site closure when that information is better understood.

The end use objective will affect the type of decommissioning undertaken. This may include:

- Alternate use.
- Abandon in place.
- Demolition and removal (i.e. the removal of buildings, equipment, and installed features).



- A combination thereof.

Elements of the decommissioning plan will include:

- Evaluation of decommissioning alternatives.
- Sequencing of activities.
- A strategy to identify and remediate disturbed areas.
- Details of the demolition and removal activities to be undertaken.
- Restoration and re-vegetation.

For safety of personnel and the environment, decommissioning activities of the proposed San Fernando WWTP will be implemented after operations have ceased and equipment has been properly deactivated. The Government of the Republic of Trinidad and Tobago (GORTT) will be notified when decommissioning is scheduled. A revised plan will be prepared and provided to GORTT when decommissioning is more imminent, but no less than 12 months before closure is planned.



## 4. Analysis of Alternatives

The objective of an analysis of alternatives is to describe reasonable alternatives to any project beginning with an assessment of the project siting options, through to an analysis of the technical and design consideration and ending with an assessment of a no action alternative. For this project, the overriding project goal is to reduce the pollution loading from the discharge of untreated or partially treated wastewater from homes, commercial, instructional and industrial entities in the San Fernando Catchment area. The goal of the project is to be realised through the following key project objectives:

- Connection of all point sources of discharge of wastewater from homes, commercial, institutional and industrial entities in the San Fernando catchment areas to a centralized sewer collection and treatment system.
- Establishment of an interconnected network of new and existing lateral sewers, trunk sewers, lines and lift stations that will serve as an integrated wastewater collection system.
- Upgrade of the San Fernando WWTP to have the capacity to effectively handle all of the wastewater treatment needs of the catchment area while using modern secondary and tertiary treatment technology to consistently produce an effluent quality that meets the standards for discharge to inland water courses in Trinidad and Tobago, and for reuse in agricultural injection or industrial end-uses.

Alternative measures to achieve these key project objectives are discussed below.

### 4.1 Wastewater Treatment Plant Location

The best location for the new San Fernando WWTP would be at the lowest elevation in the catchment so wastewater can be conveyed to the plant site by gravity and minimize the need for expensive pumping. In this case, locating the WWTP anywhere near the Gulf of Paria would meet this criterion.

Available sites along the Gulf are limited because the area within the San Fernando Project boundaries is highly developed. The existing San Fernando WWTP site is just north of the Ciperó River upstream of its discharge point to the Gulf of Paria. As will be described later in this Section, this site has sufficient land area to build the new WWTP while keeping the existing WWTP in service. The existing site has a number of major advantages over a new “greenfield site” elsewhere in the catchment. These advantages are:

- Major trunk lines serving San Fernando Proper terminate at this site.
- Location is adjacent to the Ciperó River resulting in a short outfall.
- Land is already owned by WASA.

### 4.2 Type of Collection System

Primary objectives of the project are protection of public health and safeguarding the environment. In this regard four alternative sewer systems were evaluated regarding their ability to adequately address these concerns. These are:

- Low Pressure System



- Vacuum System
- Small Gravity Diameter (SGD) System
- Conventional Gravity Sewer System

#### 4.2.1 Low Pressure System

There are two basic types, the Septic Tank Effluent Pump System (STEP) and the Grinder Pump system (GP)

##### 4.2.1.1 Septic Tank Effluent Pump System (STEP)

In a STEP system a grinder pump is installed in the existing septic tank. The pump forces the wastewater through a force main into either a larger diameter low pressure sewer and/or into a conventional gravity sewer. Modifications to the existing septic tanks would be required to accommodate the pump and the operation of the system would resemble that of a sump pump.

While this system has advantages in areas with difficult site conditions such as high water tables, undulating topography, sites with ground elevation lower than that of the main gravity sewer, and is also relatively cheaper than conventional gravity systems in low density development areas, it requires the operation and maintenance of the grinder pump at each household. This puts the responsibility of pump maintenance and operation upon the homeowner. This factor is viewed as a major drawback to the success of the STEP system in meeting environmental and health concerns of the project. If faulty septic tanks leak, this system will be prone to failure. This system is not sufficiently reliable and therefore eliminated from further consideration.

##### 4.2.1.2 Grinder Pump (GP) System

The GP system is similar to the STEP system except that the existing septic tank is removed and a self contained grinder pump complete with tanks is directly tied into the household's plumbing system. Wastewater is pumped directly into the low pressure sewer through a small diameter discharge pipe system.

Advantages to the system are similar to the STEP system in that it is suited to sites with high water tables, difficult topography, isolated areas and in cases where ground elevation is lower than that of the main sewer. It is also relatively cheaper than conventional gravity sewer systems. The disadvantage is that it requires each household to operate and maintain the grinder pump, and for this reason was considered prone to failure and not recommended for the project.

#### 4.2.2 Vacuum System

In a vacuum sewer system, the vacuum sewer lines operate under a vacuum pressure (i.e., 380mm to 625mm Hg) created by vacuum pumps located at the main vacuum station. The pressure differential between the atmospheric pressure and the vacuum in the sewer lines, forces open valves and draws the wastewater through the sewer lines.

Typically, domestic wastewater flows by gravity through individual service lines from as many as four homes into a sealed fibreglass chamber. As the wastewater level rises inside the chamber, increased pressure of air trapped inside activates valves causing wastewater to flow to the main vacuum station.



Vacuum pumps at the main vacuum station transfer the wastewater through a discharge force main to either a conventional gravity wastewater collection sewer and/or directly to the wastewater treatment facility.

This system is advantageous in areas of undulating topography, poor load bearing soils, with high ground water tables and in areas where property ground elevation is lower than that of the main gravity sewer. The system, however, is fairly complex, requires regular maintenance and is prone to failure. Disruption to the homeowner during installation and change-over of systems is relatively longer than for a conventional gravity sewer system. The vacuum sewer system was not recommended due to its operational complexity and maintenance requirements.

#### 4.2.3 Small Diameter Gravity (SDG) System

SDG systems utilize existing septic tanks as settling basins to remove grease, grit and other heavy solids. The supernatant from the septic tanks then flows into a small diameter sewer. Septic tanks need to be emptied at regular intervals. The main advantage of the SDG system is that it is comparatively less costly than conventional gravity sewer systems in terms of capital cost.

One disadvantage is that the SDG system would not achieve the project goals of public health protection and safeguarding the environment if existing septic tanks continue to leak. Many existing septic tanks need to be completely rebuilt and made watertight if the SDG system is to be able to achieve the objectives of the project. Septic tanks also need to be emptied at regular intervals to reduce the risk of overflow and increased threat to public health and environmental pollution. Septage removed from the septic tanks needs to be treated either at a septage treatment facility or the proposed new WWTP. SDG does not reduce the requirement for treatment it merely defers it.

Assuming that SDG is adopted, all existing leaking septic tanks would need to be replaced or repaired, and maintained in optimum condition if the system is to be successful. If WASA was to undertake the replacement, inspection and maintenance of septic tanks, then capital costs of the SDG system would likely be more than that of the conventional gravity system. For these reasons the SDG system was not recommended for this project.

#### 4.2.4 Centralized Conventional Gravity Sewer System

The conventional gravity wastewater collection system collects all wastewater using individual service connection piping into a lateral sewer and eventually into a main sewer. If the WWTP is located at the lowest point in the collection system, all flows could be conveyed by gravity; however, this is usually not practical and flows collected in low lying areas would need to be pumped. The main advantage of the system is that the public health and environmental protection issues will be safeguarded. One disadvantage is the longer disruption period during construction due to deeper trench construction and the relatively higher capital costs.

The conventional gravity sewer system is the logical choice for the San Fernando Project from a reliability viewpoint and the ability to meet the stated objectives of the project. The project terms of reference include tying in existing conventional gravity sewer systems within the project boundaries, which would have added difficulty if a different method of collection system was implemented. The



conventional gravity sewer system is also the preferred choice of WASA. Consequently this system was selected as the preferred option for the wastewater collection system for San Fernando.

### 4.3 Selection of Wastewater Treatment System

Several process options for treating liquids and solids streams have been evaluated. These options are summarized in the following sections.

#### 4.3.1 Liquids Treatment Process Options

The new San Fernando WWTP will need to include processes capable of achieving effluent quality that will meet EMA requirements for discharge to an inland water course, the Ciperó River. In addition to providing secondary treatment, WASA decided to provide tertiary filtration and high level disinfection of the secondary effluent to reclaim the water for reuse rather than discharge to the river, if appropriate users can be identified. One example would be irrigation water for the Picton Mega Farm. Options for treating the wastewater liquids are described in the following sections.

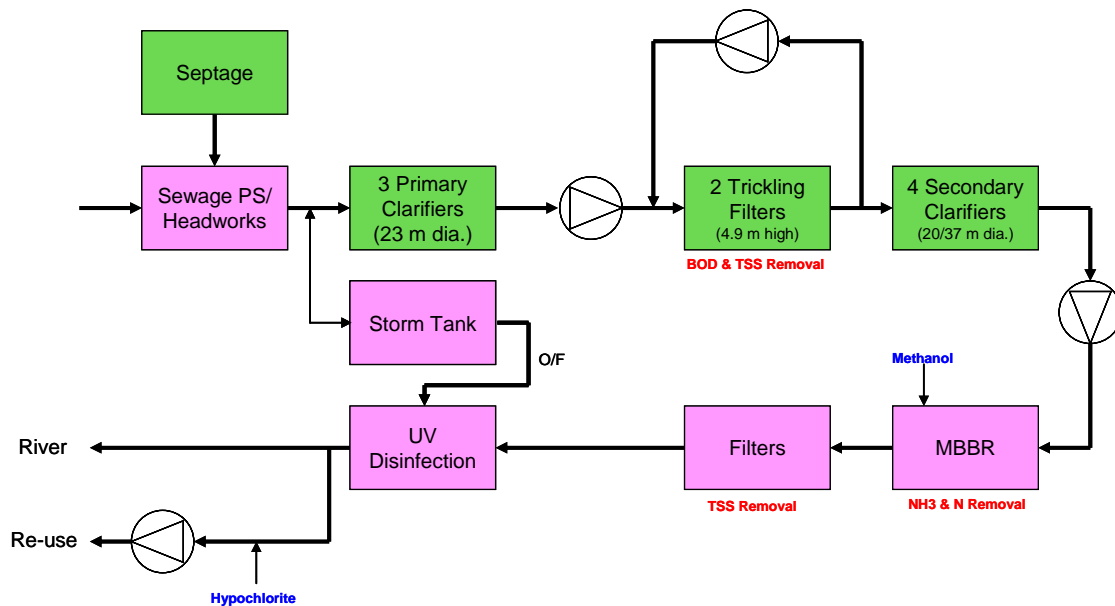
##### 4.3.1.1 Option L1 - Trickling Filter and Moving Bed Biofilm Reactor

This option uses trickling filters for BOD removal and a moving bed biofilm reactor (MBBR) for nitrogen removal.

The raw wastewater is initially pumped to the headworks, which comprises 6 mm screens and a grit removal system. Septage hauled to the site would be screened and then discharged into the influent pumping station.

This option continues to use the existing primary clarifiers, although a third clarifier is required for treating wet weather events. Flow in excess of the capacity of the primary clarifiers and secondary treatment system is diverted to a storm water tank. This temporarily stores the excess wastewater until the plant has sufficient capacity to treat the stored wastewater.

This option continues to use the trickling filter process for BOD removal; however, the rock media is replaced with plastic media and the height of the trickling filters increased. To improve performance, effluent from the trickling filter is recycled to the trickling filter inlet. Two additional secondary clarifiers are required for the higher design flow. Figure 4-1 is a flow schematic for Option L1. New process units are indicated in pink. Existing, modified, or expanded processes are green.



**Figure 4-1 Flow Schematic of Option L1**

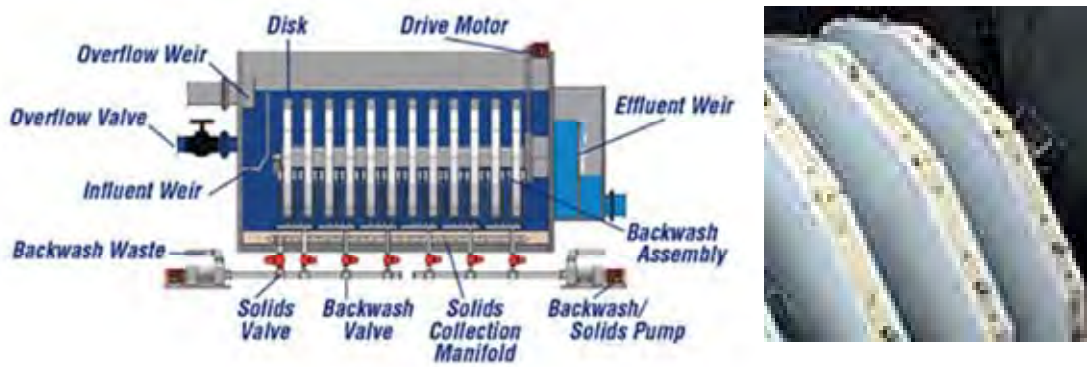
To meet the requirements for ammonia and nitrogen removal, another biological treatment stage is required. In this option a MBBR system is used for both nitrification (ammonia oxidation) and denitrification (nitrogen removal). A MBBR is a pure biofilm process without sludge recirculation. The nitrifying and denitrifying bacteria attach to the media, which are available in a variety of materials, shapes, and sizes. Typically media fill volumes are between 25% and 65% of the total tank volume.

The MBBR is divided into two zones: the first zone is aerated for nitrification, and the second zone mixed with submersible mixers. Screens are located at the end of each zone to retain the media and allow the effluent wastewater to continue downstream.

Denitrification requires a source of carbon for the denitrifying bacteria. In a conventional WWTP, the BOD in the raw wastewater is used. However, with the denitrifying MBBR downstream of the trickling filters and the nitrifying MBBR, most of the BOD will already have been removed. Therefore it is necessary to add an external carbon source to the denitrifying MBBR. Methanol is the external carbon source typically used, and is appropriate for Trinidad, given the country's large methanol production capabilities.

To remove solids generated in the MBBR, and to produce an effluent with a low TSS concentration suitable for reuse, a filtration process is required. In this option cloth-media filtration is used, as it is a low-cost method of providing filtration and meets North American regulations for producing reclaimed water. In this process the water passes through a series of rotating cloth-covered disks (Figure 4-2) into a central collection header. The filtered effluent exits the central header via a chamber equipped with an overflow. Backwashing is conducted in-situ while the discs are rotating. A series of suction shoes are used to vacuum the solids off the surface of the disk.



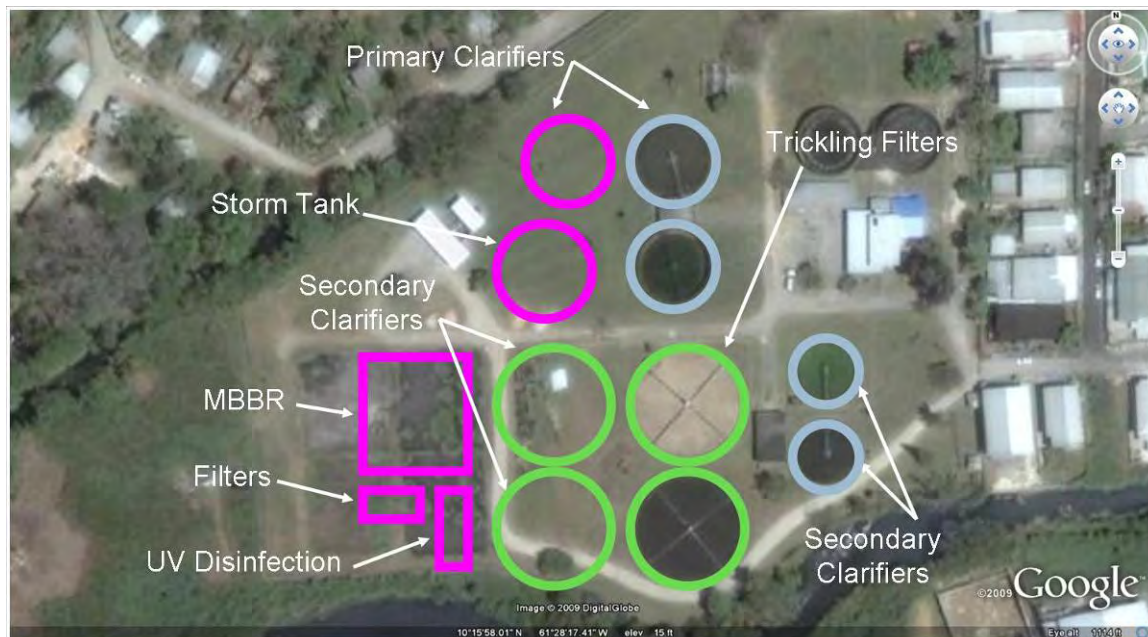


**Figure 4-2 Cloth Media Filter (Courtesy of Aqua-Aerobic Systems)**

To comply with the EMA’s Faecal Coliform requirement, the treated effluent is disinfected with ultraviolet (UV) light. The use of filters upstream of the UV disinfection means that the influent to the UV disinfection system has a low TSS and a high UV transmittance. This means that a smaller UV disinfection system can be provided, minimizing energy and lamp replacement costs.

Before discharging to the Ciperó River, some of the treated effluent will be withdrawn for reuse within the plant. To meet the stringent Faecal Coliform requirements for agricultural reuse, the reuse water will be chlorinated using sodium hypochlorite.

Figure 4-3 provides a conceptual site layout for Option L1. Units shaded in blue are existing, those in green are upgrades of existing units, and those in pink are new.



**Figure 4-3 Conceptual Site Layout of Option L1**

The advantages and disadvantages of this option are summarized in Table 4-1.



**Table 4-1 Advantages and Disadvantages of Option L1**

Advantages	Disadvantages
<ul style="list-style-type: none"><li>• Uses existing structures to a large extent.</li><li>• Multi-barrier treatment train.</li></ul>	<ul style="list-style-type: none"><li>• Need to take a trickling filter off-line for upgrade, thus compromising treatment performance.</li><li>• Significant layout and pipe routing issues.</li><li>• Difficult flow splitting between the small and large secondary clarifiers.</li><li>• Methanol safety and O&amp;M cost.</li><li>• Three major pumping stations.</li><li>• Risk of filter flies in this residential area.</li></ul>

*4.3.1.2 Option L2 - Trickling Filter and Denitrifying Filter*

This option follows the same approach as Option L1 for raw wastewater pumping, preliminary treatment in the headworks, septage management, primary clarification, storm water management, UV disinfection, and chlorination.

However, unlike Option L1, this option uses the trickling filters for both BOD removal and ammonia oxidation. Four tall plastic media biotowers are required, two of which use the existing trickling filter structures and two will be new. As with Option L1, a recirculation system is employed for the trickling filters and additional secondary clarifier capacity is required.

Like Option L1, denitrification and filtration is required. However, in Option L2, denitrification and filtration is combined into one process: denitrifying sand filtration. Methanol is added to the filters for the denitrification process. Figure 4-4 and Figure 4-5 summarize Option L2.

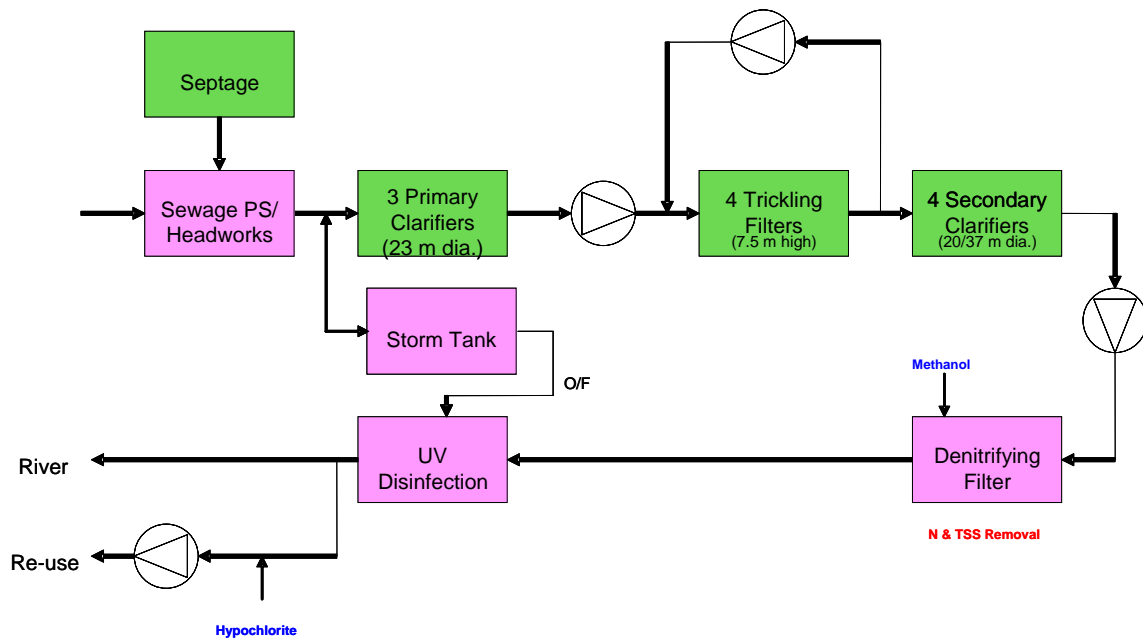


Figure 4-4 Flow Schematic of Option L2

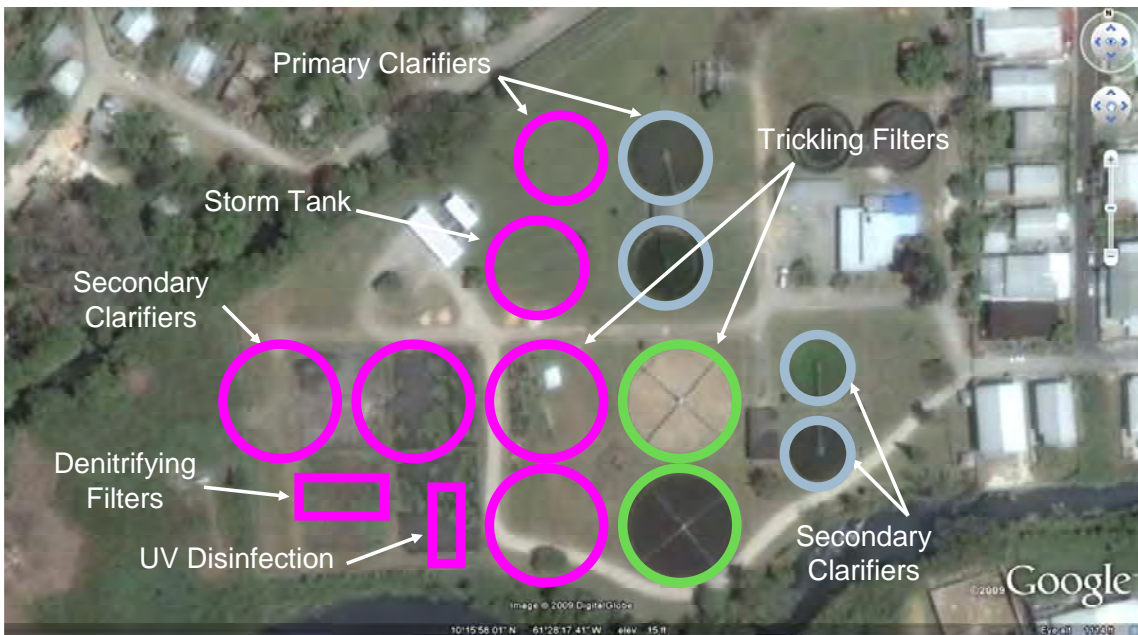


Figure 4-5 Conceptual Site Layout of Option L2

The advantages and disadvantages of this option are summarized in Table 4-2.



**Table 4-2 Advantages and Disadvantages of Option L2**

Advantages	Disadvantages
<ul style="list-style-type: none"><li>• Uses existing structures to a large extent.</li><li>• Can stage construction off-line to minimize loss of treatment capacity.</li></ul>	<ul style="list-style-type: none"><li>• Significant layout and pipe routing issues.</li><li>• Difficult flow splitting between the small and large secondary clarifiers.</li><li>• Methanol safety and O&amp;M cost.</li><li>• Risk of filter flies in this residential area.</li><li>• Tall biotowers would be visually obtrusive in this residential area.</li></ul>

*4.3.1.3 Option L3 – Activated Sludge Plant*

This option follows the same approach as Options 1 and 2 for raw wastewater pumping, preliminary treatment in the headworks, septage management, UV disinfection, and chlorination; however, unlike Options 1 and 2, this option does not require primary clarifiers. The existing primary clarifiers are used as stormwater storage tanks.

None of the existing secondary treatment plant (trickling filters and secondary clarifiers) are used in Option L3. A new activated sludge plant is constructed for combined BOD, ammonia, and nitrogen removal.

To produce an effluent with a low TSS concentration suitable for reuse, a filtration process is required. As with Option L1, cloth-media filtration is employed.

Figure 4-6 and Figure 4-7 summarize Option L3.

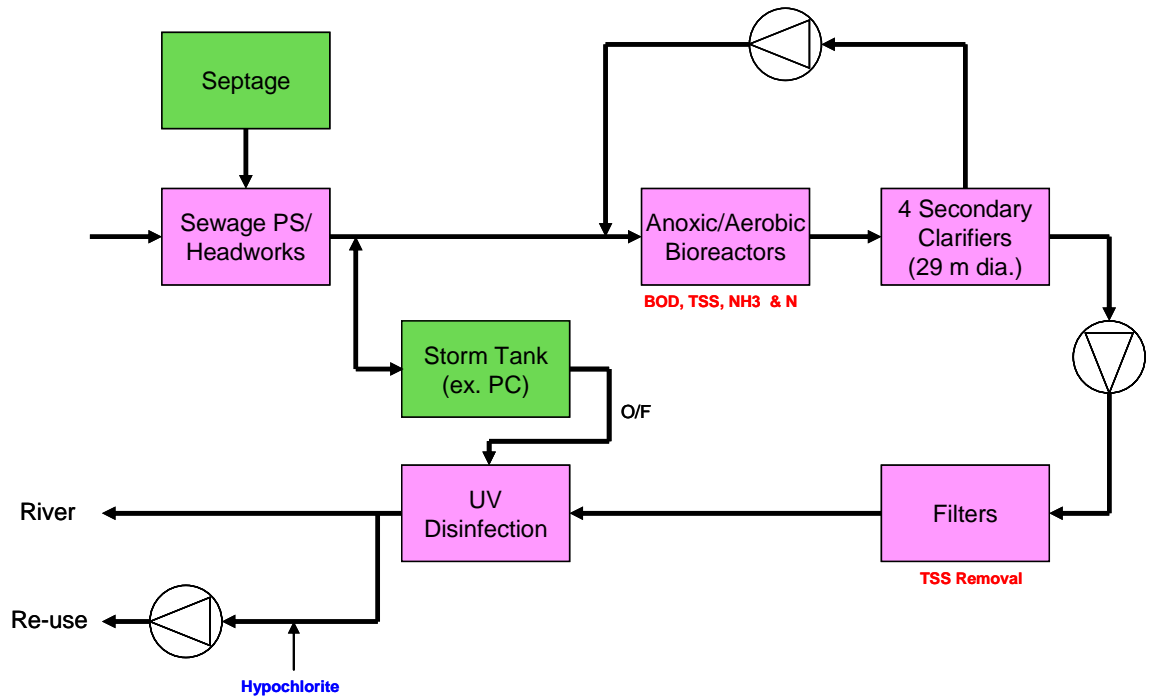


Figure 4-6 Flow Schematic of Option L3

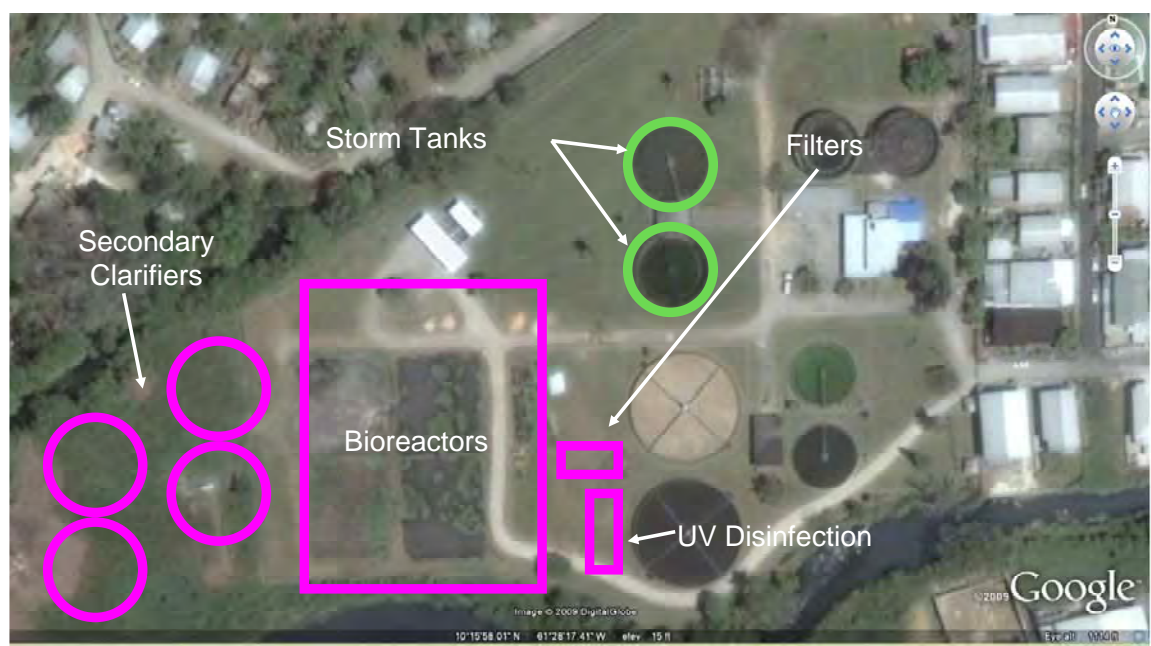


Figure 4-7 Conceptual Site Layout of Option L3

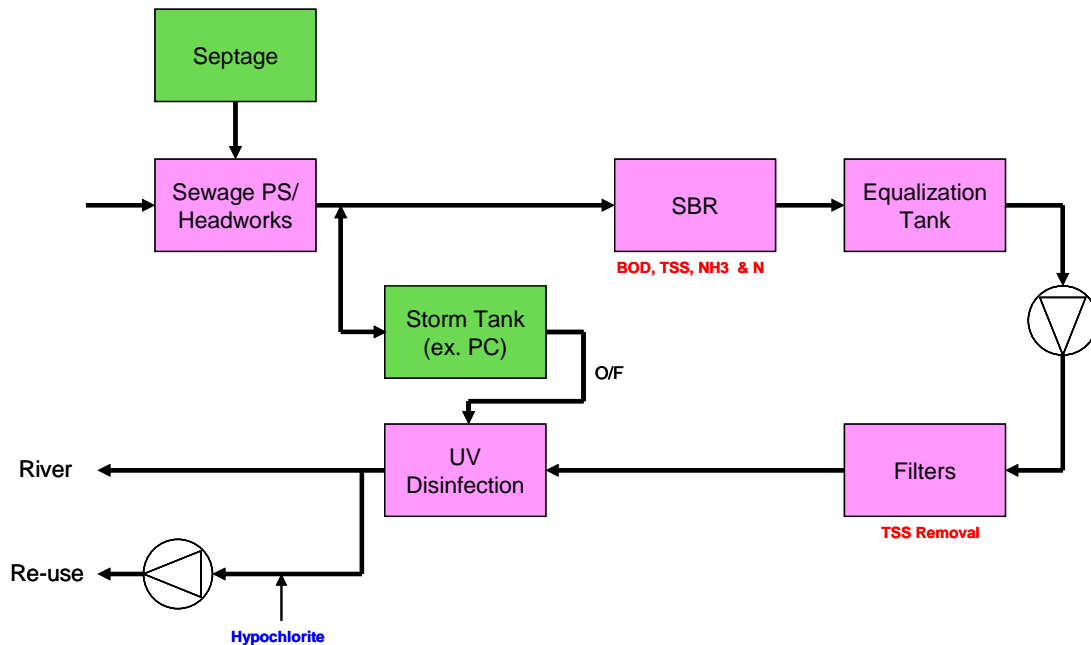
The advantages and disadvantages of this option are summarized in Table 4-3.

**Table 4-3 Advantages and Disadvantages of Option L3**

Advantages	Disadvantages
<ul style="list-style-type: none"> <li>• New plant can be built off-line, minimizing disruption to existing operation.</li> <li>• WASA familiar with operating this process.</li> <li>• Proven in Trinidad.</li> <li>• No methanol.</li> <li>• Can demolish existing structures for future expansion.</li> </ul>	<ul style="list-style-type: none"> <li>• Predominantly new structures.</li> </ul>

*4.3.1.4 Option L4 – Sequencing Batch Reactor*

Option L4 is identical to Option L3 except that sequencing batch reactors (SBRs) are used for secondary treatment rather than flow-through activated sludge. SBRs are an activated sludge process that operates in a batch mode. For a plant of this size, it would be typical to provide four SBR tanks to minimize the size of the downstream equalization tank. SBRs can be provided in a number of shapes including circular and rectangular with common wall construction. Figure 4-8 and Figure 4-9 summarize Option L4.



**Figure 4-8 Flow Schematic of Option L4**



**Figure 4-9 Conceptual Site Layout of Option L4**

The advantages and disadvantages of this option are summarized in Table 4-4.

**Table 4-4 Advantages and Disadvantages of Option L4**

Advantages	Disadvantages
<ul style="list-style-type: none"> <li>• Relatively compact plant.</li> <li>• No methanol required.</li> <li>• Modular and therefore easy to expand, although there is not much room for expansion at the site.</li> </ul>	<ul style="list-style-type: none"> <li>• Predominantly new structures.</li> <li>• Process not familiar to WASA.</li> <li>• Not proven in Trinidad.</li> </ul>

#### 4.3.1.5 Option L5 – Membrane Bioreactor

This option is similar to the activated sludge option, but it uses membranes rather than clarifiers for solids separation. Since the bioreactors can run at higher mixed liquor concentrations, they are smaller than those in the activated sludge option. To protect the membranes from fouling, two-stage screening is provided; the second stage screens have perforations of 1 to 2 mm. The filtering effect of the membranes eliminates the need for separate cloth-media filters. Although the membranes filter the bacteria, it is common practice to disinfect MBR effluent, and hence a UV disinfection plant is provided.

Figure 4-10 and Figure 4-11 summarize Option L5.

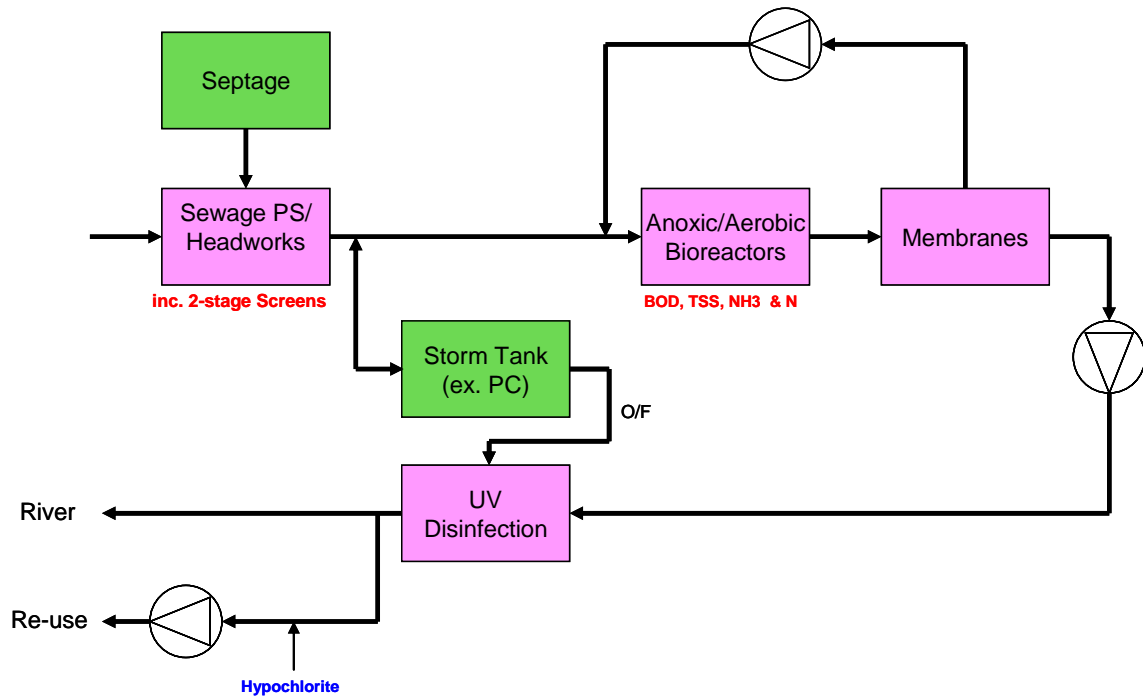


Figure 4-10 Flow Schematic of Option L5

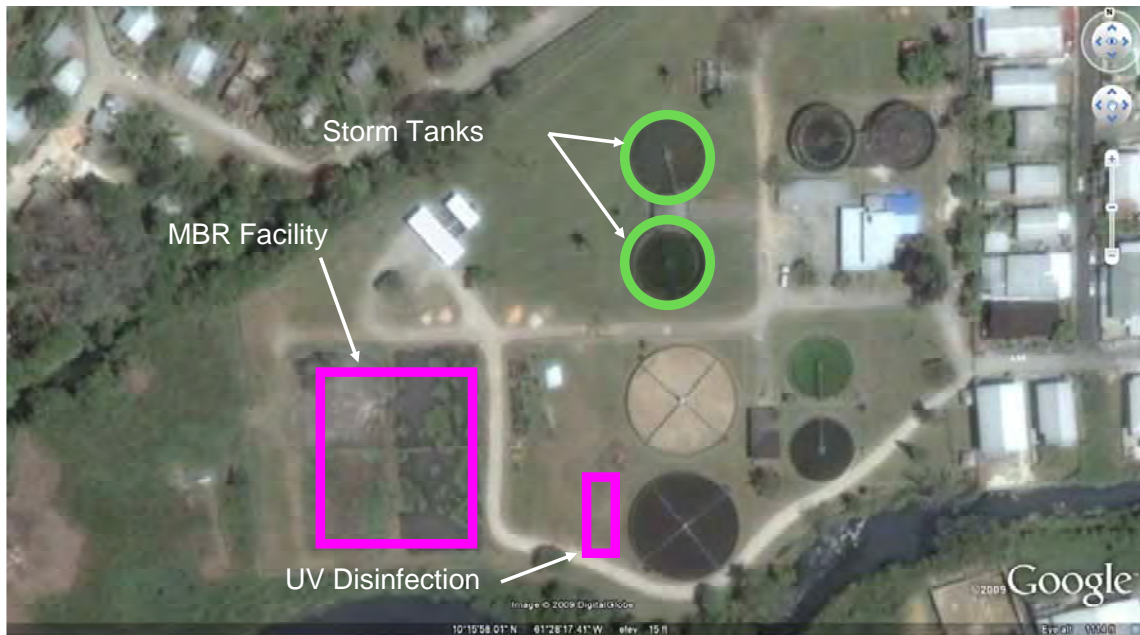


Figure 4-11 Conceptual Site Layout of Option L5

The advantages and disadvantages of this option are summarized in Table 4-5.



**Table 4-5 Advantages and Disadvantages of Option L5**

Advantages	Disadvantages
<ul style="list-style-type: none"> <li>• Compact plant.</li> <li>• Very high quality of effluent, likely to be better than what is actually required.</li> </ul>	<ul style="list-style-type: none"> <li>• Predominantly new structures.</li> <li>• Equipment-intensive.</li> <li>• Higher equipment redundancy requirements.</li> <li>• Chemicals for membrane cleaning.</li> <li>• High energy usage.</li> <li>• Membrane replacement costs.</li> </ul>

### 4.3.2 Comparison of the Liquid Stream Options

The five options described above were presented to WASA at a workshop. A list of key evaluation criteria was developed at the workshop, together with appropriate weighting for each criterion. The criteria used for evaluation of the options are described in Table 4-6.

**Table 4-6 Evaluation Criteria**

Criteria	Description
<b>Technical</b>	
Proven Reliability	Ability to reliably produce the required effluent quality, with an emphasis on being proven in Trinidad and Tobago.
Robustness	Ability to respond to varying conditions, such as shock loads.
Flexibility	Ability to respond to varying operational requirements, such as taking unit out of service, and redundancy requirements
Space Requirements	Footprint
Expandability	Ease with which the process can be modularized and expanded
Constructability	Ease of construction with an emphasis on the effects of construction on the existing operating plant.
<b>Operational</b>	
Ease of Operations	The ability of the process to be easily operated.
Ease of Maintenance	Refers to how equipment-intensive the process is.
Operator Safety	Predominantly refers to chemicals and chemical handling
Operator Environment	The working environment to which the operational staff are exposed
<b>Environmental &amp; Aesthetics</b>	
Visual Impact	The visual impact of the structures on the neighbouring community
Noise	Relative noise of the process
Odour/Dust	Odour and dust generated as part of normal operation, including dust from vehicle access.
<b>Economic Criteria</b>	
Relative Construction Cost	Generic comparison of capital cost
Relative O&M Cost	Predominantly refers to electrical power costs and chemical costs



Each criterion was given a rating from 1 to 5 (with 5 being the best) and a weighting of 1 to 5 (with 5 being the most important).

Table 4-7 summarizes the evaluation of the five options.

**Table 4-7 Rating Table of Options**

	Weighting (1 to 5)	Option L1 TF+MBBR+F	Option L2 TF+DF	Option L3 AS	Option L4 SBR	Option L5 MBR
<b>Technical</b>						
Proven Reliability	5	4	3	5	3	2
Robustness	5	2	3	5	5	1
Flexibility	4	1	3	5	5	5
Space Requirements	2	4	3	3	3	5
Expandability	3	1	1	5	5	5
Constructability	2	1	3	5	5	5
<b>Operational</b>						
Ease of Operation	4	2	3	5	5	1
Ease of Maintenance	4	2	3	5	4	1
Operator Safety	4	1	1	5	5	3
Operator Environment	2	1	1	4	4	5
<b>Environmental &amp; Aesthetic</b>						
Visual impact	3	4	2	4	4	5
Noise	4	3	5	2	2	1
Odour/ Dust	4	3	3	5	5	5
<b>Subtotal</b>		<b>105</b>	<b>125</b>	<b>209</b>	<b>195</b>	<b>139</b>
<b>Economic Criteria</b>						
Relative Construction Cost	5	5	3	3	4	1
Relative O&M Cost	4	3	2	3	3	1
<b>Subtotal</b>		<b>37</b>	<b>23</b>	<b>27</b>	<b>32</b>	<b>9</b>
<b>Overall Weighed Scoring as a Parentage of the Maximum Possible Score</b>		<b>47%</b>	<b>54%</b>	<b>90%</b>	<b>84%</b>	<b>59%</b>

The option rating, which takes into account issues specific to the San Fernando site; indicate that the activated sludge plant and the sequencing batch reactor plant are the most appropriate for San Fernando. The activated sludge plant has a slightly better rating than the SBRs.

For a publically-owned authority like WASA, the main issue with SBRs is related to procurement. SBRs are marketed as an overall system by equipment suppliers who provide the process design



(including tank dimensions), the aeration system (blowers and fine bubble diffusers, or floating surface aerators) decanters, waste activated sludge pumps, controls and instrumentation. In a conventional design-bid-build contract, as in the San Fernando WWTP, the design engineer would need to select the SBR system from a particular vendor, and then design the WWTP around this vendor's process. When the WWTP contract is tendered, the bidders have only the one SBR supplier that they can procure equipment from. This limits competition, and does not provide a transparent approach in the tendering process. There are methods to alleviate this issue, such as competitive tendering for the SBR system in advance of design. However, this approach extends the design period, and would also require that WASA issue a purchase order to an SBR supplier prior to the design. In summary, although SBRs are an excellent technology for wastewater treatment, comparable to activated sludge, they are not commonly used for large publically-owned design-bid-build wastewater treatment plants. SBRs are far more common in privately-owned wastewater treatment plants (e.g. industrial plants) or in design-build projects. The SBR system, although ranked highly, is therefore not recommended in this case.

For the San Fernando WWTP, it is recommended that the activated sludge process be used. The activated sludge system had the highest rating, it is a proven technology in Trinidad, and WASA is familiar with its operation and maintenance requirements.

Having selected the activated sludge system for San Fernando WWTP, the method of bioreactor aeration must be chosen. The two most popular methods of aeration are slow-speed surface aeration and fine bubble diffused aeration.

A conceptual design for both a surface aeration plant and a fine bubble aeration plant has been prepared. Each is described in detail below.

The surface aeration plant would be similar to the system already used by WASA, at Beetham. It would comprise bioreactors, with anoxic mixers, four recycle pumps, and two-speed surface aerators. To minimize noise and spray from the surface aerators, a tank freeboard of 1 m would be provided.

The fine bubble plant would have the same overall reactor volume as the surface aerator plant, but would be divided into different numbers of reactors than the surface aeration plant. Complete replacement of all fine bubble diffusers in a tank is typically conducted every five to seven years. In addition, emptying of each tank once a year for inspection and replacement of broken diffusers and air piping is standard practice. Each reactor would include anoxic mixers, and internal recycle pumps. A blower building with five positive displacement blowers (four on duty, one standby) would be provided. The blowers would be equipped with acoustic enclosures. In addition, the blower building would have acoustic cladding to minimize nuisance noises affecting nearby residents. The fine bubble plant would have deeper tanks than the fine bubble plant for efficient aeration.

A cost comparison of the two options is provided in the Table 4-8.

**Table 4-8 Conceptual Cost Comparison of Surface Aeration and Fine Bubble Aeration**

	Surface Aeration	Fine Bubble
<b>Capital Cost</b>		
Structural/Building	TT\$ 47 M	TT \$46 M
Process Equipment	TT \$20 M	TT \$25 M
Electrical/I&C	TT \$6 M	TT \$6 M
<b>Total</b>	<b>TT \$73 M</b>	<b>TT \$77 M</b>
<b>O&amp;M Cost</b>		
Aeration Power <sup>2</sup>	TT \$23 M	TT \$20 M
Additional Pumping Power	-	TT \$0.6 M
Diffuser Replacement	-	TT \$3 M
<b>Total</b>	<b>TT \$23</b>	<b>TT \$23.6 M</b>
<b>Present Value <sup>1</sup></b>	<b>TT \$ 96 M</b>	<b>TT \$ 100.6 M</b>

**Notes:**

1. PV based on discount rate of 4% over 25 years.
2. Based on TT\$ 0.396/kWh
3. These costs are for comparison only, and do not include contractor mark-ups, contingency, taxes, engineering etc.

The above analysis shows that the main capital cost difference between the two options is the equipment cost. This is because all of the equipment (except the aeration equipment) for fine bubble is in triplicate rather than in duplicate. Nonetheless, the present worth for the two systems is not significantly different. Based on discussions with WASA, it was decided to use fine bubble aeration mainly because it was considered to be better suited for the site with nearby residential developments.

### 4.3.3 Solids Treatment Process Options

Residuals produced at the new WWTP will include screenings, grit, and waste solids from the activated sludge process. Screenings and grit will be washed, dewatered, and then deposited in bins for hauling to and disposing of the materials at landfill.

The following solids unit processes are typically used for treating waste solids produced by activated sludge systems:

- Thickening
- Dewatering
- Solar drying
- Lime stabilization
- Composting
- Aerobic Digestion
- Storage

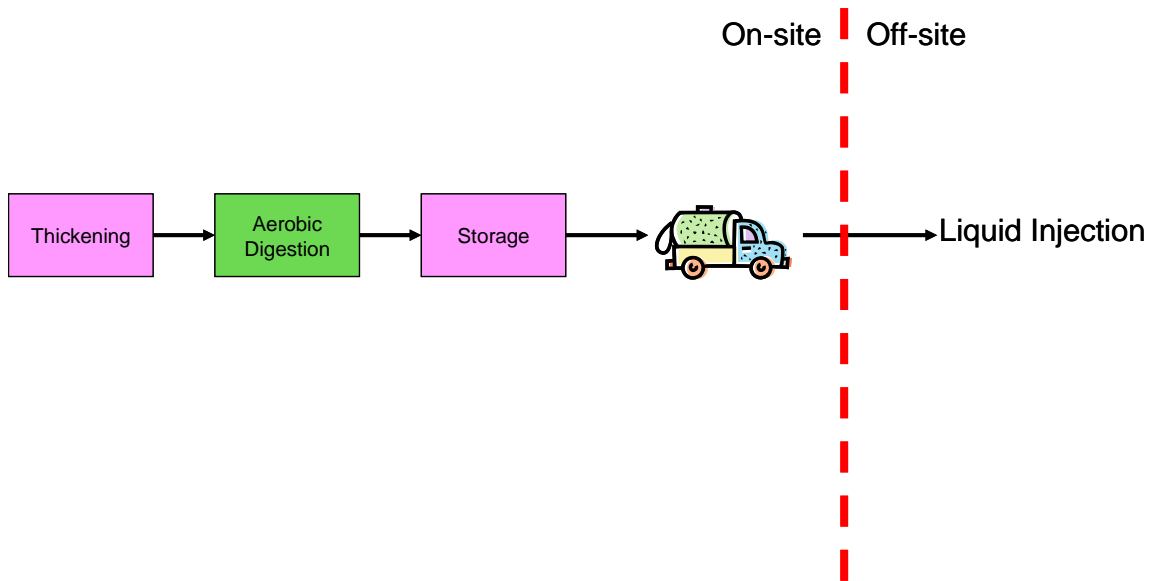
A series of solids stream treatment options have been developed using one or more of the above technologies. These options are appropriate for activated sludge plants without primary clarifiers, and hence do not include anaerobic digesters, which is the stabilisation process currently used at the existing WWTP where primary solids are available. The solids stream options are as follows:



- Option S1 – Aerobic Digestion and Liquid Disposal
- Option S2 – Aerobic Digestion and Cake Disposal
- Option S3 – Lime Stabilization
- Option S4 – Composting
- Option S5 – Solar Drying

#### 4.3.3.1 Option S1 – Aerobic Digestion and Liquid Disposal

Option S1 involves thickening of the waste activated sludge, aerobic digestion, on-site storage and eventual off-site reuse of the liquid biosolids by sub-surface injection on agricultural land. In this option the existing anaerobic digesters are reused as aerobic digesters (or storage tanks). Figure 4-12 summarizes Option S1.



**Figure 4-12 Schematic of Option S1**

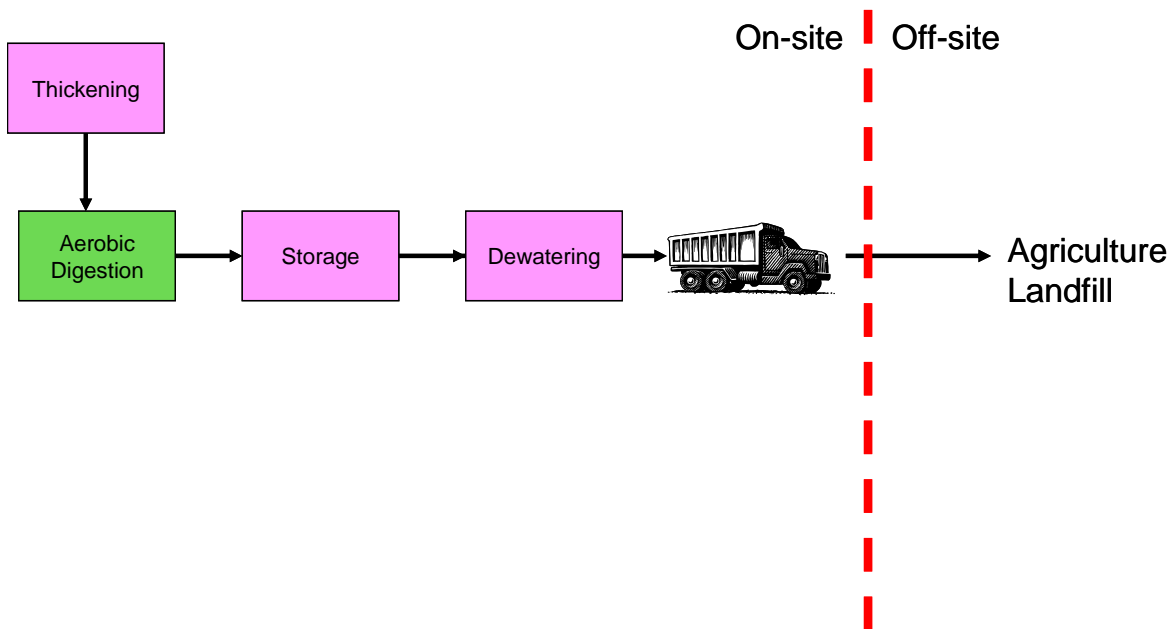
The advantages and disadvantages of this option are summarized in Table 4-9.

**Table 4-9 Advantages and Disadvantages of Option S1**

Advantages	Disadvantages
<ul style="list-style-type: none"> <li>Minimal number of treatment processes, making for easy operation and maintenance.</li> <li>Uses existing anaerobic digesters as aerobic digesters or storage tanks.</li> <li>Widely used in Trinidad.</li> </ul>	<ul style="list-style-type: none"> <li>Liquid transportation off-site. Means large number of trucks driving through residential areas and high hauling costs.</li> <li>Liquid injection may be an issue during the rainy season.</li> <li>Only one outlet for the product: agriculture.</li> </ul>

*4.3.3.2 Option S2 – Aerobic Digestion and Cake Disposal*

Like Option S1, Option S2 involves thickening of the waste activated sludge and aerobic digestion. However, the digested solids are dewatered to produce a cake before being transported off-site. The cake can be disposed to landfill or beneficially reused in agriculture. Figure 4-13 summarizes Option S2.



**Figure 4-13 Schematic of Option S2**

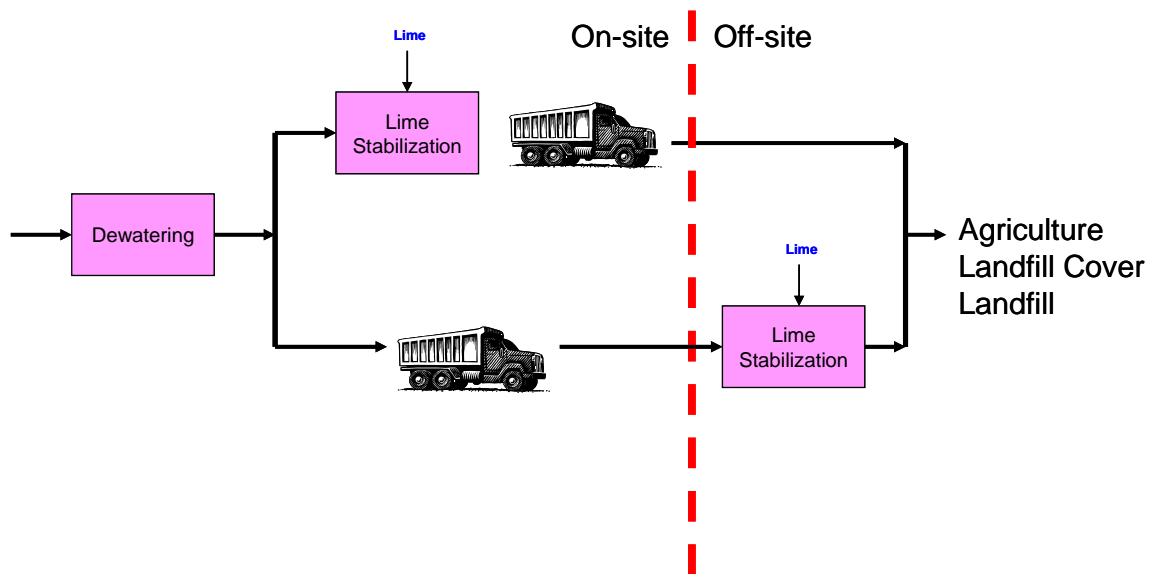
The advantages and disadvantages of this option are summarized in Table 4-10.

**Table 4-10 Advantages and Disadvantages of Option S2**

Advantages	Disadvantages
<ul style="list-style-type: none"> <li>• Uses existing anaerobic digesters as aerobic digesters or storage tanks.</li> <li>• Cake transportation minimizes traffic through residential areas and minimizes hauling costs.</li> <li>• Two outlets: Agriculture and landfill.</li> </ul>	<ul style="list-style-type: none"> <li>• Only one outlet for beneficial reuse: agriculture.</li> </ul>

*4.3.3.3 Option S3 – Lime Stabilization*

In Option S3, the waste activated sludge is dewatered to produce an un-stabilized cake. The cake is then stabilized with lime, at a lime stabilization plant, either on-site or off-site. The product of the stabilization process can be used for agriculture (in areas where low pH soils are an issue), for landfill cover, or simply disposed of at a landfill. Figure 4-14 summarizes Option S3.



**Figure 4-14 Schematic of Option S3**

The advantages and disadvantages of this option are summarized in Table 4-11.

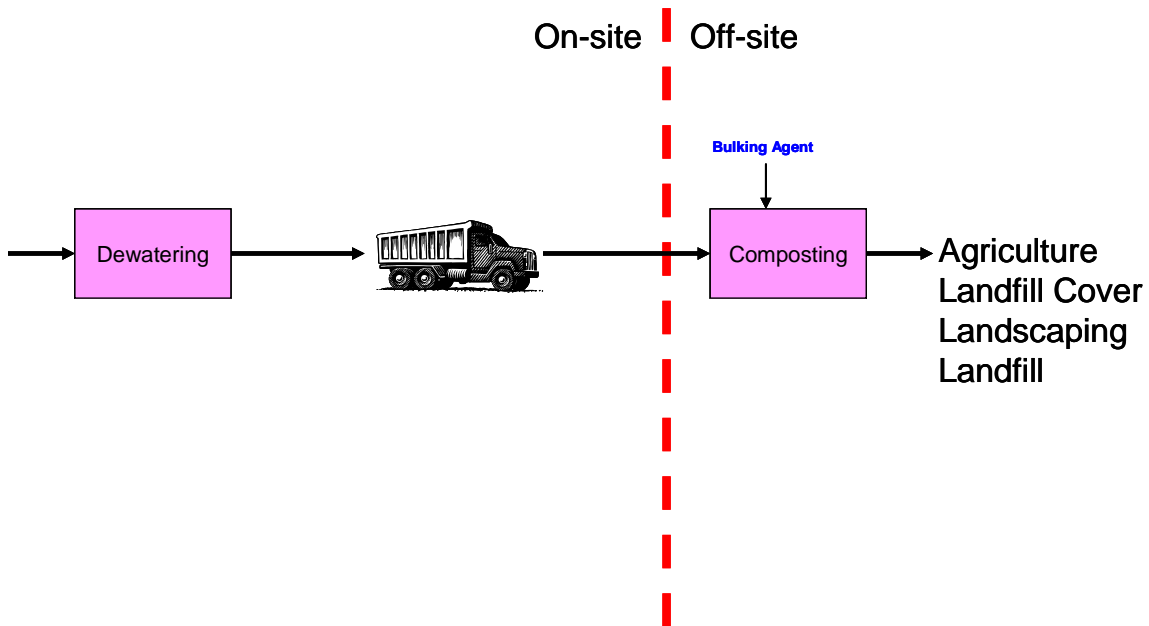


**Table 4-11 Advantages and Disadvantages of Option S3**

Advantages	Disadvantages
<ul style="list-style-type: none"> <li>• Cake transportation minimizes traffic through residential areas and minimizes hauling costs.</li> <li>• Two potential outlets for beneficial reuse: Agriculture and landfill cover.</li> </ul>	<ul style="list-style-type: none"> <li>• Additional site that needs to be operated and maintained, if lime stabilizing is located off-site.</li> <li>• Does not use existing digesters.</li> <li>• Lime handling can be an operational challenge, as well as a safety concern.</li> <li>• Relies on a chemical (lime) to operate.</li> <li>• Cost of lime.</li> </ul>

*4.3.3.4 Option S4 – Composting*

In Option S4, the un-stabilized solids from the WWTP are dewatered to a cake, and then transported off-site for composting. On-site composting is not feasible because of the large area required. A bulking agent, such as wood chips, needs to be added to the cake for composting. The compost can be beneficially reused in agriculture, for landfill cover and landscaping, or can simply be disposed of at a landfill. Figure 4-15 summarizes Option S4.



**Figure 4-15 Schematic of Option S4**

The advantages and disadvantages of this option are summarized in Table 4-12.



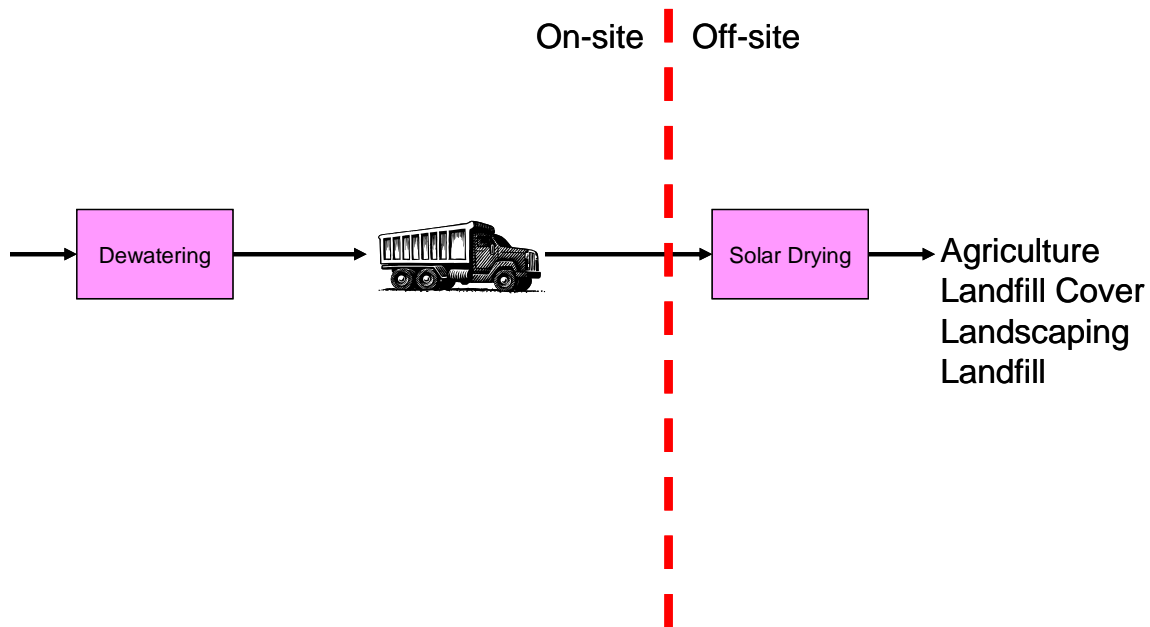


**Table 4-12 Advantages and Disadvantages of Option S4**

Advantages	Disadvantages
<ul style="list-style-type: none"> <li>• Cake transportation minimizes traffic through residential areas and minimizes hauling costs.</li> <li>• Three potential outlets for beneficial reuse: Agriculture, landfill cover, and landscaping.</li> <li>• Potential to run the composting at a SWMCOL landfill site.</li> </ul>	<ul style="list-style-type: none"> <li>• Additional site that needs to be operated and maintained, since composting would be located off-site.</li> <li>• Does not use existing digesters.</li> <li>• Relies on a bulking agent to work.</li> </ul>

*4.3.3.5 Option S5 – Solar Drying*

Like Option S4, the un-stabilized solids from the WWTP are dewatered to a cake, and then transported off-site. However, rather than composting, the cake is stabilized and dried by the sun in greenhouses. On-site solar drying is not feasible because of the large area of greenhouses required. The dried product can be beneficially reused in agriculture, for landfill cover and landscaping, or can simply be disposed of at a landfill. Figure 4-16 summarizes Option S5.



**Figure 4-16 Schematic of Option S5**

The advantages and disadvantages of this option are summarized in Table 4-13.



**Table 4-13 Advantages and Disadvantages of Option S5**

Advantages	Disadvantages
<ul style="list-style-type: none"> <li>• Cake transportation minimizes traffic through residential areas and minimizes hauling costs.</li> <li>• Three potential outlets for beneficial reuse: Agriculture, landfill cover, and landscaping.</li> <li>• Potential to run the drying operation at a Mega Farm site.</li> </ul>	<ul style="list-style-type: none"> <li>• Additional site that needs to be operated and maintained, since drying would be located off-site.</li> <li>• Does not use existing digesters</li> </ul>

#### 4.3.4 Comparison of the Solids Stream Options

The five options described above were presented to WASA at a workshop. The same evaluation criteria that were used for the liquids stream options were used for the solids stream options; however, the weighting procedure was different to reflect the different priorities involved in solids management.

As with the liquids stream options, each criterion was given a rating from 1 to 5 (with 5 being the best) and a weighting of 1 to 5 (with 5 being the most important).

Table 4-14 summarizes the evaluation of the five options.

**Table 4-14 Rating Table of Options**

	Weighting (1 to 5)	Option S1 Dig.	Option S2 Dig. Cake	Option S3 Lime	Option S4 Compost	Option S5 Solar Dry
<b>Technical</b>						
Proven Reliability	5	5	5	1	1	3
Robustness	4	4	5	1	1	5
Flexibility	4	1	2	4	3	5
Space Requirements	5	5	4	3	2	1
Expandability	3	1	1	5	4	3
Constructability	3	3	3	5	2	2
<b>Operational</b>						
Ease of Operation	4	4	5	1	3	3
Ease of Maintenance	4	4	3	1	3	3
Operator Safety	4	4	4	1	3	3
Operator Environment	2	5	4	1	3	2
<b>Environmental &amp; Aesthetic</b>						
Visual impact	3	3	3	2	1	3
Noise	4	1	2	3	3	3
Odour/ Dust	0	5	4	1	2	3
<b>Subtotal</b>		<b>153</b>	<b>158</b>	<b>102</b>	<b>106</b>	<b>136</b>

**Table 4-14 Rating Table of Options (continued)**

	Weighting (1 to 5)	Option S1 Dig.	Option S2 Dig. Cake	Option S3 Lime	Option S4 Compost	Option S5 Solar Dry
<b>Economic Criteria</b>						
Relative Construction Cost	5	4	3	5	3	4
Relative O&M Cost	5	3	4	1	2	5
<b>Subtotal</b>						
<b>Subtotal</b>		<b>35</b>	<b>35</b>	<b>30</b>	<b>25</b>	<b>45</b>
<b>Overall Weighted Score as a Percentage of the Maximum Possible</b>		<b>68%</b>	<b>70%</b>	<b>46%</b>	<b>47%</b>	<b>62%</b>

This rating of the options takes into account issues specific to the San Fernando site, and solids reuse and disposal issues specific to Trinidad. The results indicate that aerobic digestion and cake dewatering (Option S2) is the most appropriate for San Fernando. The second highest rated option, S1 (Hauling Liquid Sludge from the digesters) could also be incorporated into the treatment plant simply by providing a tanker truck filling station. A further advantage of Option S2 is that it does not preclude WASA from installing an off-site solar drying plant in the future, say at one of the Mega Farms.

#### 4.4 No Action Alternative

An alternative to the proposed project is ‘No Action’ in which the proposed project is not undertaken. The proposed development is part of a larger WASA Wastewater Master Plan that has identified the need for improved wastewater treatment in Trinidad and Tobago. Implications of the ‘No Action’ alternative are that the problems that have been identified in the catchment area and surrounding area will continue and are acceptable.

The problem of non-functional wastewater treatment plants (WWTPs) servicing private housing developments has been a persistent wastewater and surface water management issue in Trinidad for several decades. The identification of these small private WWTPs and the inefficient treatment of sewage resulting in the pollution of watercourses, have been assessed over the last decade with many of the privately owned WWTPs identified as non-functional (Rodriguez-Atwell 2000).

Without the proposed project, urbanization and population growth will result in increasing volumes of untreated domestic and small quantities of industrial wastewater being discharged into the rivers and drains and a consequent deterioration in surface water quality. The pollution of surface water would continue to affect and threaten drinking water safety and thus the health of urban and rural residents. The area’s ecosystem, and particularly aquatic life, will be significantly degraded. The downstream water quality in the Guaracara, Marabella, Vistabella and Cipro Rivers will be negatively affected. The quality of life and the standard of living of residents of the project area will deteriorate.



Implementation of the proposed project will significantly reduce the direct discharge of untreated wastewater, thereby contributing to the long-term goal of cleaning up the rivers within the catchment area and improving related ecological, physical, and health conditions.



## 5. Biophysical Environment Setting

### 5.1 Introduction

Trinidad is located 11° N and 61° W on the southern end of the Caribbean archipelago. The island is approximately 5,000 km<sup>2</sup> and is surrounded by the Gulf of Paria on the west, Caribbean Sea in the north, Columbus Channel to the south and Atlantic Ocean in the east.

The San Fernando Wastewater Project area is located in south-western Trinidad. The physical area of the catchment is bordered by Guaracara River to the north, M2 Ring Road to the south, Solomon Hochoy Highway to the east, inclusive of Ste. Madeline, and the Gulf of Paria on the west (Figure 3-1).

The TOR set by the EMA declared that a detailed survey of the biophysical environment was required in order to meet the CEC guidelines. This is necessary to determine the baseline conditions within the natural environment so the impact of the project could be determined based on an evaluation of the existing situation and the cumulative impacts of simultaneous projects within the study area.

The baseline conditions that were identified included all aspects of the ecological environment such as:

- Climate
- Natural Hazards
- Geology
- Soils
- Topography
- Hydrology
- Water Quality
- Flora
- Fauna
- Ambient Noise
- Ambient Air

Surveys were conducted throughout the project schedule and secondary research was carried out to supplement the data collected. Each characteristic of the biophysical environment will be discussed in this Section.

### 5.2 Climate

Trinidad has two clearly defined seasons; a dry and wet season on an annual basis. The dry season extends from January to May and is distinguished by little rainfall or drought spells and higher temperatures. The wet season starts in June and ends in December and opposite climatic conditions occur including heavy rainfall and lower temperatures.

The climate of Trinidad does not vary much spatially. Climate would be discussed in the context of wind speed and direction, temperature, humidity and precipitation. These parameters are measured by the Meteorological Services of Trinidad and Tobago under the Ministry of Public Utilities. The



stations managed by this division are located in north-eastern Trinidad at the Piarco International Airport and the information was obtained for the Piarco area from an internet weather service called Weather Underground Incorporated. The monthly average of each parameter was used for this baseline assessment.

### 5.2.1 Wind Speed and Wind Direction

Mean monthly wind speed values for the period January 2005 to April 2010 provide an average indication of the wind speed experience in Trinidad and therefore within the project area. Figure 5-1 presents these values in graph and tabular form. As depicted the highest wind speeds are typically experienced from January to July of each year with the speed decreasing in the last 5 months of the year. Between the periods 2005 to 2010, the year 2010 had the highest recorded wind speeds to date. The highest winds were felt in February and lowest in August. The generally observed trend is that the mean wind speed fluctuates on a monthly basis between 2 km/hr and 8 km/hr.

The wind direction in Trinidad is predominantly north easterly since the island is affected by the North East Trade Winds. The trade winds are created when the winds flow from the subtropical high points to the low pressure zone called the Inter Tropical Convergence Zone (ITCZ). In the Northern Hemisphere these trade winds blow in a north-easterly direction. Northeast Trade Winds are dominant between November and July. When the ITCZ shifts northward the South East Trade Winds dominate from August to October.

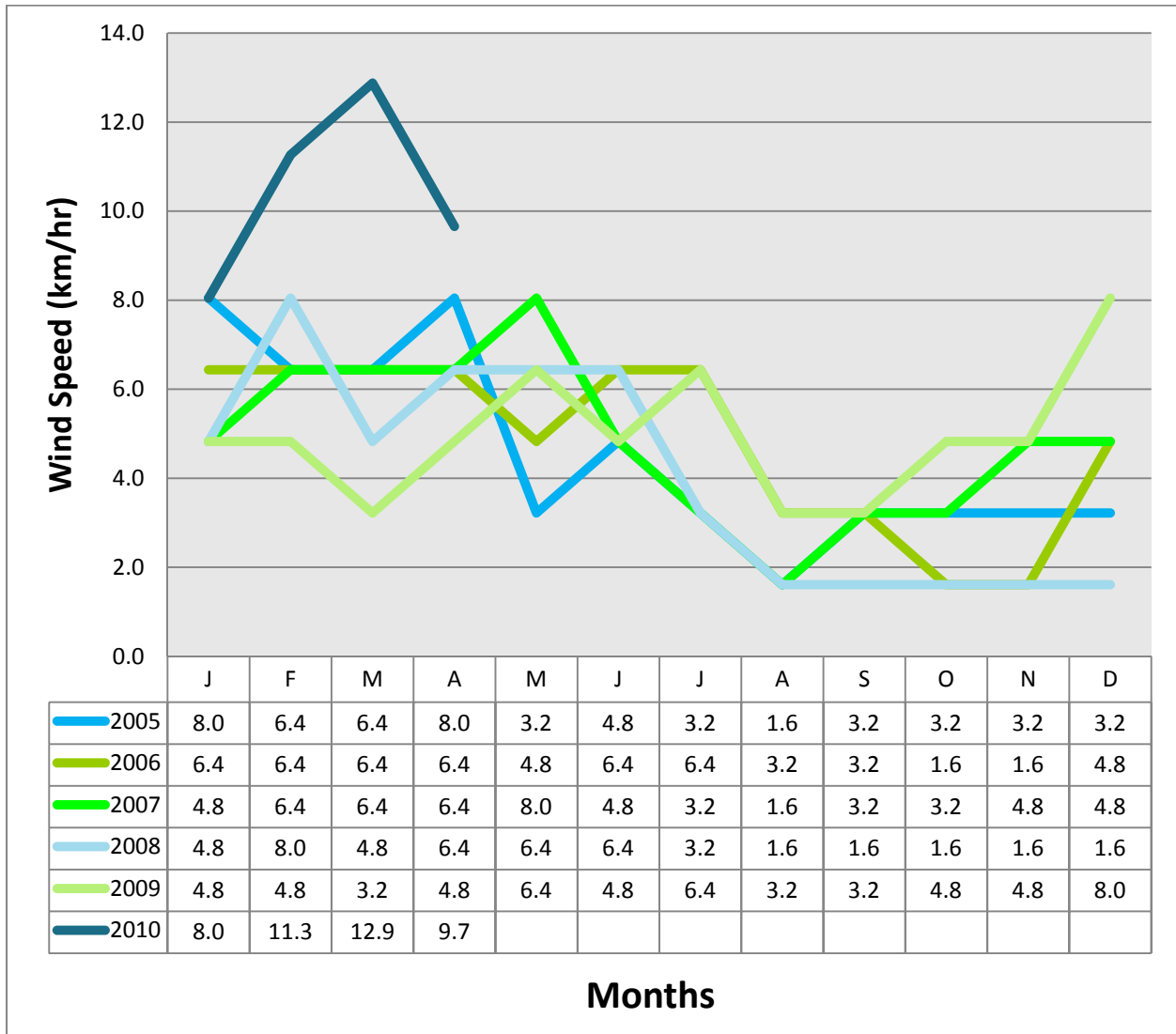


Figure 5-1 Mean Monthly Wind Speeds (Weather Underground Inc.)

### 5.2.2 Temperature

The temperature data for Trinidad recorded at Piarco International Airport was also obtained from Weather Underground Incorporated. The mean monthly temperatures for the period January 2005 to April 2010 are illustrated in Figure 5-2. Similar to the wind speed experienced in Trinidad the temperature records are highest for the period January 2010 to April 2010 inferring that 2010 has seen a drastic change in climate on the island. Generally, lower temperatures are recorded from November to February with January having the lowest temperatures for each of the 6 years. Higher temperatures are felt from March to October peaking in May and September.

Typically, during the month of September and primarily October there is a sudden flux in temperature values that is a result of the climate phenomena called ‘Petit Careme’. This is also known as the second



dry season where similar conditions are experienced in these months as in the established dry season. Proceeding, 'Petit Careme' the temperature declines until January of the following year.



Figure 5-2 Mean Monthly Temperatures (Weather Underground Inc.)

### 5.2.3 Humidity

The humidity levels in Trinidad are fairly high due to its tropical location. In some months, the maximum humidity level is 100% however the average monthly humidity ranges from 70% to 85%. The lowest humidity levels have been recorded from March to May with lowest values in April. The humidity gradually increases from May to July until it remains fairly constant from July to January, peaking in October. Humidity levels slightly increase during September and October as a result of 'Petit Careme' contributing to the dry season conditions felt during this period.



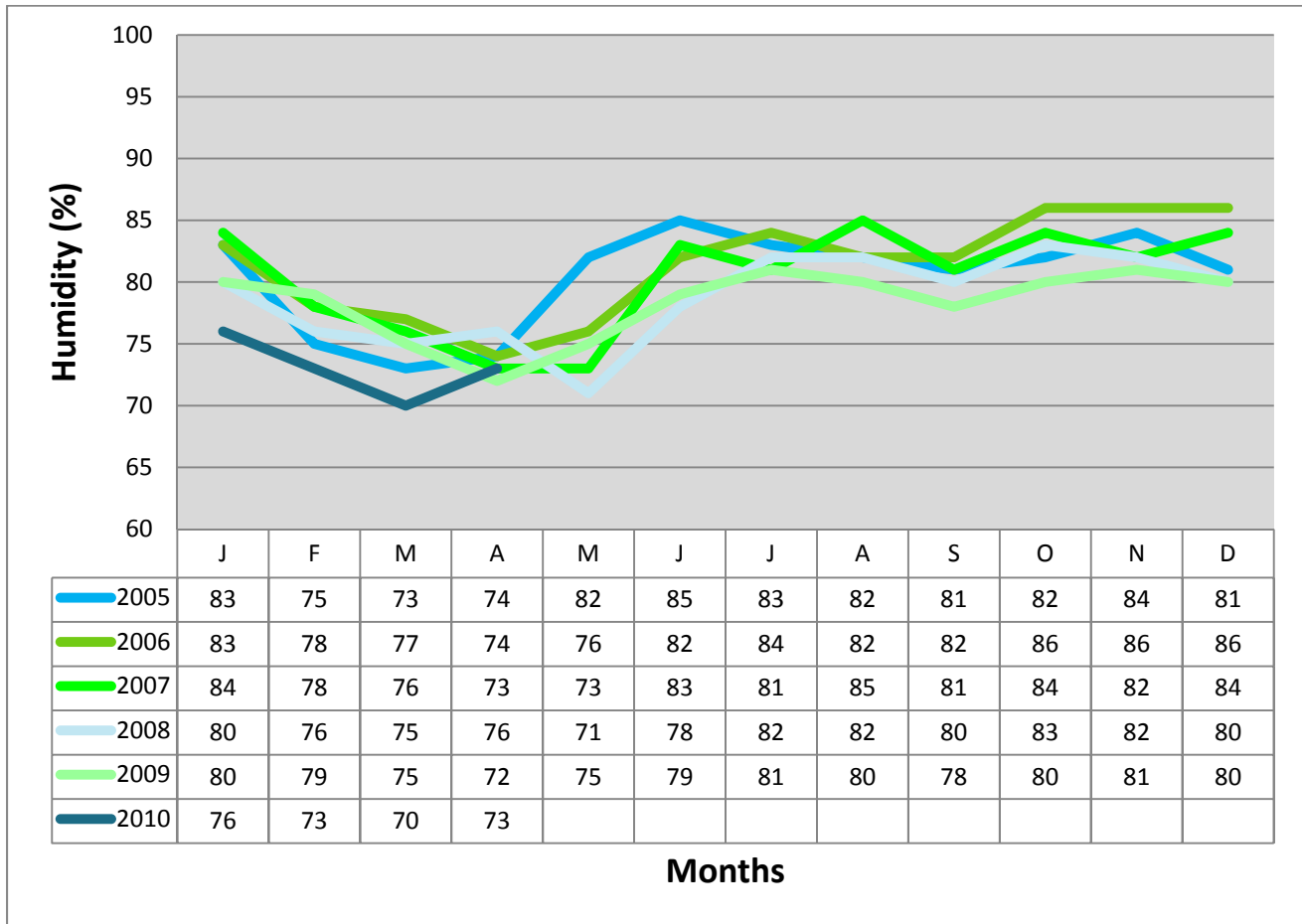


Figure 5-3 Mean Monthly Humidity (Weather Underground Inc.)

### 5.2.4 Precipitation

Precipitation levels are dictated by the wet and dry seasons experienced in Trinidad. During the dry season, commencing in January, rainfall levels are low and continue to decrease until April and sometimes May with the lowest precipitation typically being experienced in February (Figure 5-4). The month of May usually indicates the start of the wet season and rainfall levels increase until August.

In the ‘Petit Careme’ season which occurs from September to October, precipitation decreases but is followed by heavy rainfall events for the rest of the wet season. November typically has the highest rainfall levels based on this historic data. The spatial difference in rainfall is depicted in Figure 5-5. As illustrated, the San Fernando Project area is expected to have a 75 year mean annual rainfall of 1600 mm.

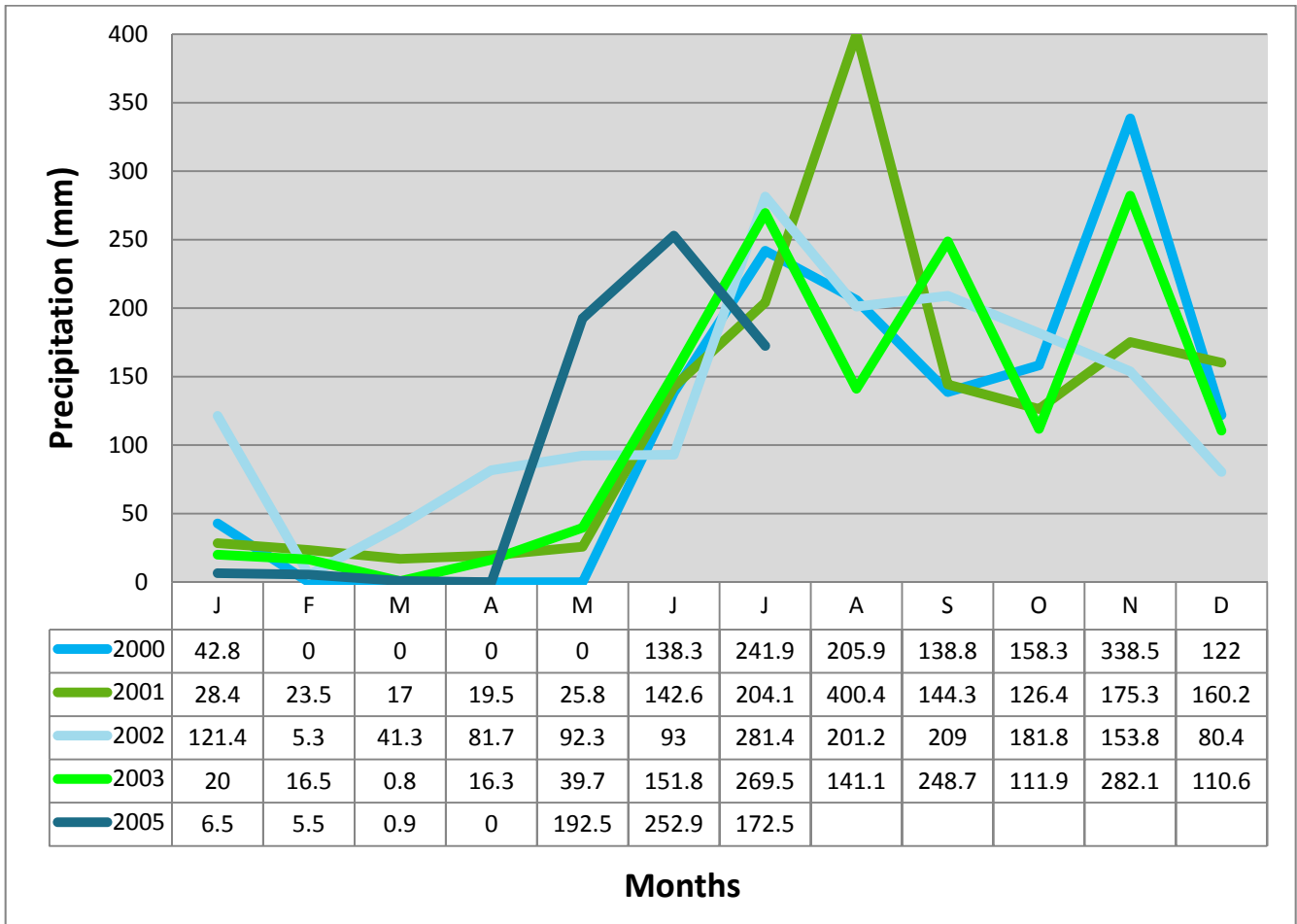


Figure 5-4 Mean Monthly Precipitation (Meteorological Services Division)

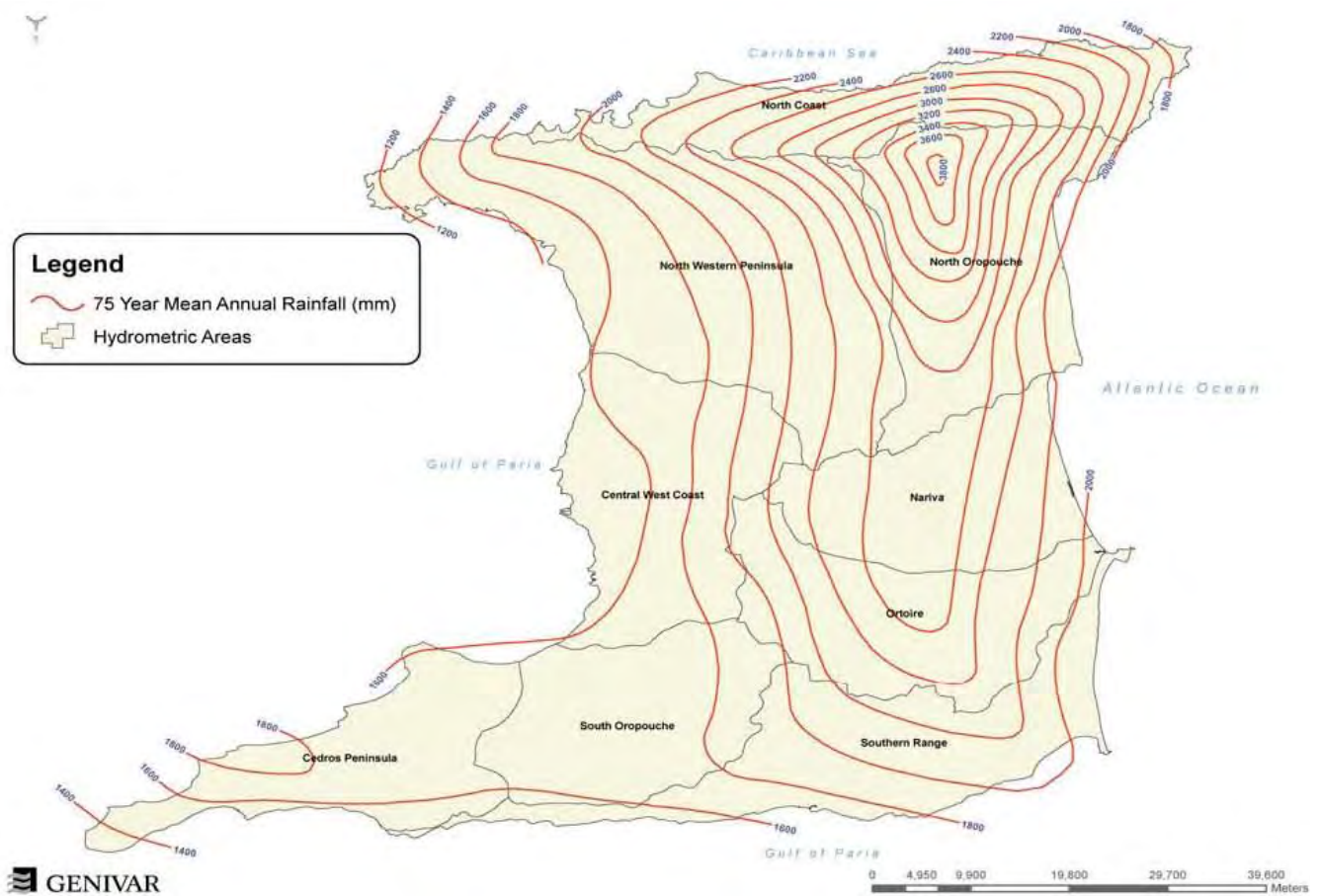


Figure 5-5 Isohyetal Map of Trinidad (Genivar, 2009)

### 5.3 Natural Hazards

Trinidad like any other country is prone to many natural hazards. Whether these hazards result in a disaster depends on the community in which it occurs and therefore the effect the event has on the population. Natural hazards are uncommon but not impossible in the San Fernando Wastewater Catchment area. The different types of events that can potentially occur are discussed in the context of Trinidad drawing specific reference to communities within the project area where these disasters have occurred, or where due to existing conditions, these communities are likely to have a high incident possibility.

#### 5.3.1 Floods

Flooding is a natural hazard that frequently occurs in Trinidad during the wet season, mainly between July and August. Flooding occurs after heavy rainfall events when rivers overflow on to their banks into surrounding agricultural lands, residential areas, business communities and roads. The San Fernando Wastewater Catchment is not largely affected by flooding due to its topography as explained in Section 5.6. The main waterways; Ciperó, Guaracara and Marabella Rivers rarely overflow because



of different hydrological factors that influence the possibility of flooding; mainly the aerial extent of the drainage catchment in comparison to the size of the river. Flood events therefore mainly affect Northern and Central Trinidad as well as communities south and east of the project area. The effects of flooding are usually;

- Loss and damage to property.
- Obstruction to traffic and roadways.
- Loss of vegetation and agricultural produce.

### 5.3.2 Bush Fires

Bush fires may or may not be considered a natural hazard because in some cases the fires are ignited manually. However, this occurrence still affects many residents of Trinidad and Tobago specifically in the dry season when the trees and grass are most susceptible to igniting. The San Fernando Wastewater Catchment area is predominantly developed land therefore bush fires are not as common. The less developed subcatchments such as Ste. Madeline, Palmiste South and Retrench/Golconda were most affected by the bush fires that occurred in the dry season of 2010. The effects of bush fires have to be considered as well for this project and they mainly include:

- Loss of vegetation and agricultural crops.
- Loss of wildlife and habitat.
- Loss and damage to property.

### 5.3.3 Hurricanes

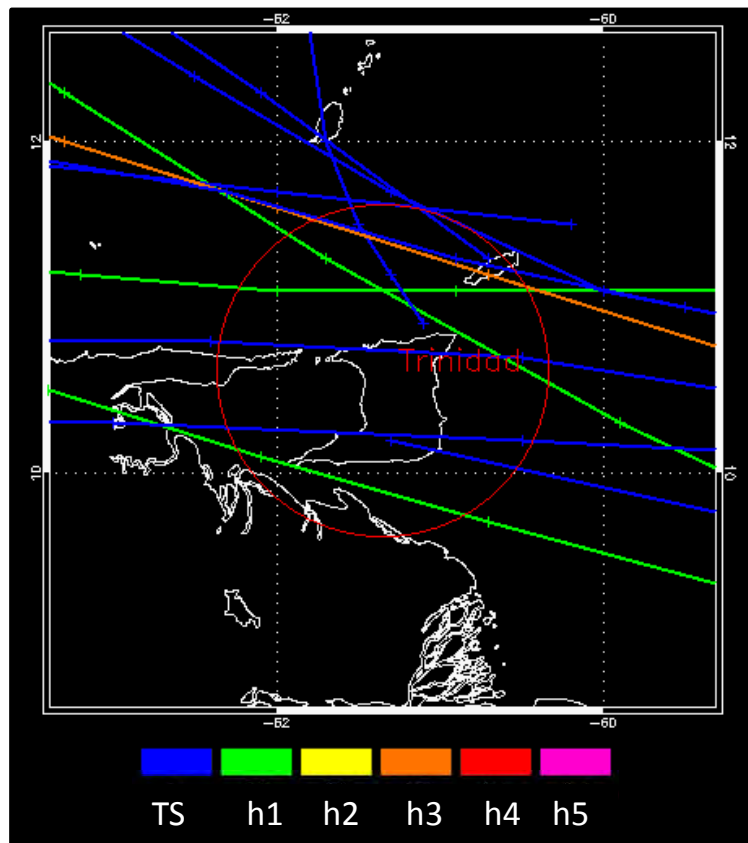
Hurricanes are common to the Caribbean region because it is in the direct path of the Atlantic Hurricane Track. The hurricanes form on the west coast of Africa and eventually move over the Atlantic Ocean increasing in intensity as they approach the Caribbean. Fortunately, Trinidad is located slightly southwest of the track and, as a result, is not in the direct path of these hurricanes. The hurricane season in Trinidad ranges generally from June to November. Figure 5-6 portrays the hurricane routes from 1851 to 2008. As illustrated only tropical storms have directly passed over Trinidad while category 1 hurricanes have mainly passed off the coast in the marine waters. Table 5-1 lists the names and wind speeds of these hurricanes and tropical storms.

A tropical storm is usually categorised by wind speeds of 63 to 118 km/hr and category 1 hurricanes have wind speeds between 119 and 153 km/hr. The last tropical storm that passed over Trinidad was Joyce in October 2000. Despite the historic tracks, hurricanes that pass close to the island still cause heavy rainfall, flooding, rough waters and high winds.



**Table 5-1 List of Hurricanes and Tropical Storms Affecting Trinidad**

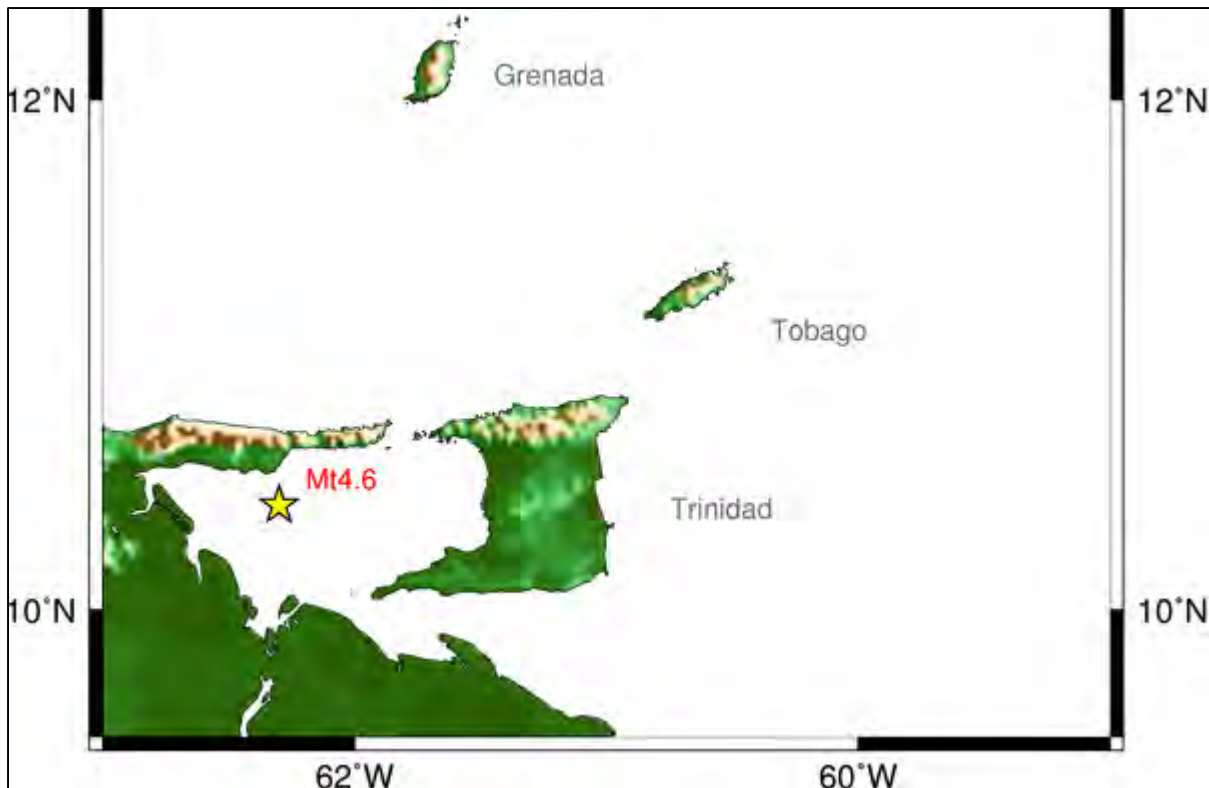
Name of Hurricane/Tropical Storm	Date	Category	Wind Speeds (km/hr)
No Name	September 1878	1	148
No Name	October 1892	1	130
No Name	November 1896	Tropical Storm	74
No Name	August 1928	Tropical Storm	64
No Name	June 1933	1	130
Anna	July 1961	Tropical Storm	84
Flora	October 1963	3	204
Alma	August 1974	Tropical Storm	74
Arthur	July 1990	Tropical Storm	84
Fran	August 1990	Tropical Storm	64
Bret	August 1993	Tropical Storm	93
Joyce	October 2000	Tropical Storm	64



**Figure 5-6 Hurricane Tracks for Trinidad during the period 1851 to 2008 (Storm CARIB Caribbean Hurricane Network)**

### 5.3.4 Earthquakes

Trinidad and Tobago is located at the boundary of the Caribbean and South American Plates therefore placing the islands in an earthquake prone zone. Major earthquakes have been prevalent in recent times within the Lesser Antilles. Most of the earthquakes that occur close to Trinidad are low magnitudes, the last one having occurred on April 21, 2010 in the Gulf of Paria; magnitude 4.6 and depth 4 km (The University of the West Indies Seismic Research Centre). Figure 5-7 depicts the location of the epicentre of this earthquake and despite the distance from Trinidad the activity was still felt in parts of Northern Trinidad.



**Figure 5-7 Recent Seismic Activity in Trinidad on 21 April 2010**

The last two major earthquakes to hit Trinidad occurred on the same day of November 22 2009 with a magnitude of 5.0 and 5.1. Shocks were felt in both northern and southern Trinidad with no major damage recorded. Seismic activity records from 1900 to 2005, indicate the epicentres of these earthquakes mainly in the coastal regions with magnitudes lower than those within the Lesser Antilles (Figure 5-8).

Earthquake prediction has become very popular since the earthquake that occurred in Haiti in February 2010. The Seismic Research Unit at the University of the West Indies has undertaken continuous investigations of plate tectonics and seismicity in the Caribbean. The Unit has formulated a predictive hazard map for earthquakes for the entire region. The hazard map for Trinidad is illustrated in Figure 5-9 and portrays the potential acceleration of particles if an earthquake were to occur.

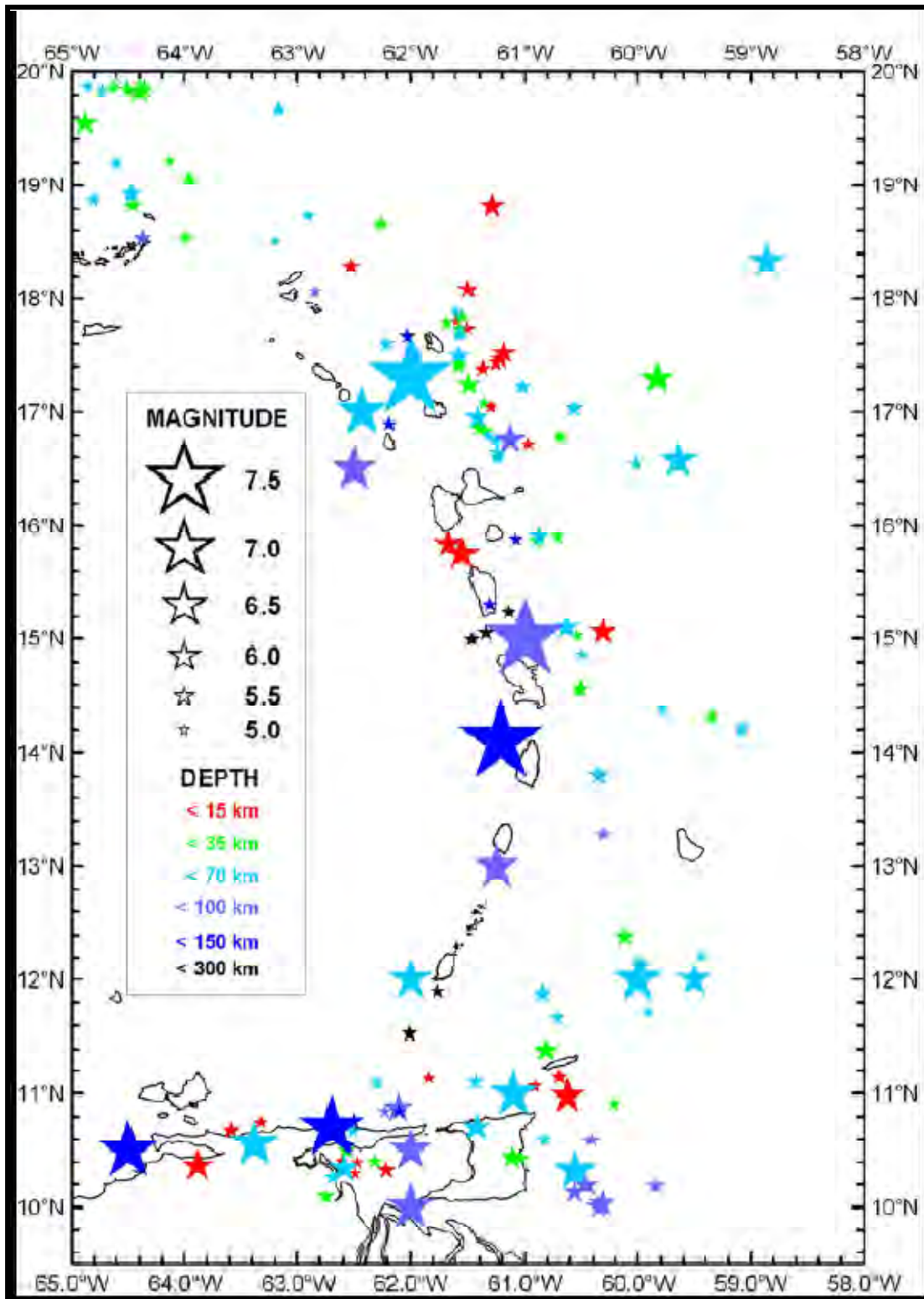
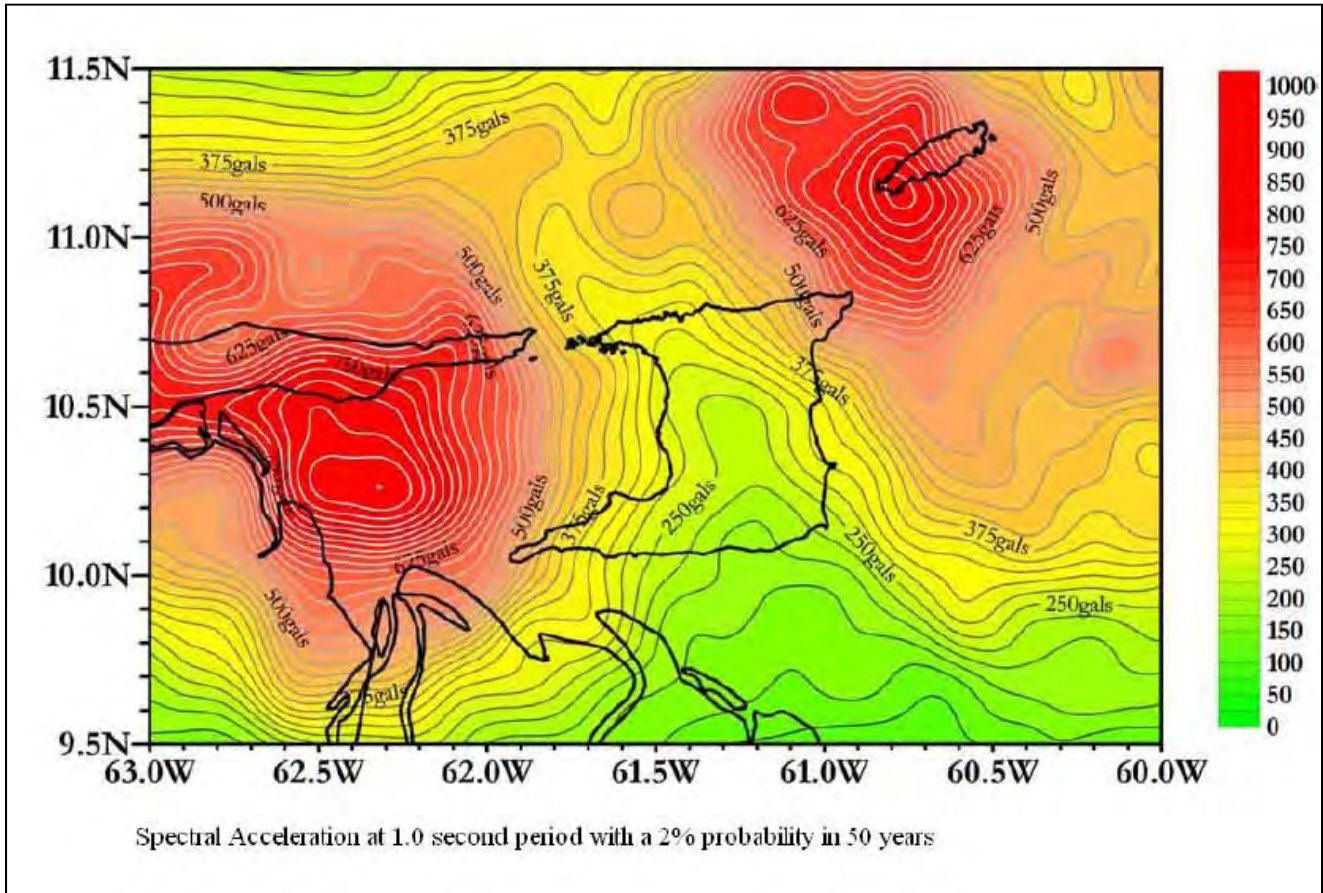


Figure 5-8 Earthquake Epicenters with Magnitudes Greater Than 5 from 1900 to 2005



**Figure 5-9 Seismic Hazard Map of Trinidad**

The possible effects of earthquake activity include:

- Collapsed structures
- Damaged infrastructure
- Slope movement
- Tsunamis
- Liquefaction

### 5.3.5 Tsunami Hazards

Tsunamis in the Caribbean region have not created as much destruction to life and property as the other natural hazards. According to the Seismic Research Unit, a tsunami can form within the Caribbean in three instances, through;

- Local earthquakes occurring at a depth of less than 50 km with a minimal magnitude of 6.5.
- Distant earthquakes occurring outside of the Caribbean but producing ‘tele-tsunamis’.
- Submarine volcanic eruption displacing water to generate a tsunami.





Even though Trinidad has not been affected by a major tsunami event, the possibility exists. A Tsunami and Coastal Hazard Warning System was implemented in March 2010 by the Office of Disaster Preparedness and Management (ODPM), however the Pacific Warning System will also be able to identify a potential tsunami wave.

## 5.4 Soils

Soil investigations were undertaken at the San Fernando WWTP and within the collection system. Geotech Associates Limited was sub-contracted to conduct the geotechnical investigations for this project. Work at the WWTP was completed in December 2009 and for the Collection System in April 2010, both geotechnical reports are attached in **Appendix D.1**.

### 5.4.1 San Fernando WWTP

The soil at the WWTP was classified according to the Soils Map of Trinidad and Tobago produced by the Lands and Survey Division of the Ministry of Planning, Housing and the Environment (Figure 5-10). The soil type is described as Sevilla Clay which is deep alluvial soil with restricted internal drainage. The soil profile at the SFWWTP site comprises mainly cohesive material and can be divided into 3 units based on soil type, standard penetration resistance, and moisture content.

Soil Unit 1 was found in a number of the borehole locations across the site and ranged from approximate depths of 4.6 metres to 6 metres below ground. The soil is very soft to soft and medium stiff silty clays. There are slight traces of sand and occasional traces of organic material, isolated gravel and peaty silty clays. In one borehole Soil Unit 1 consisted of layers of fill and stiff to very stiff silty clays. The natural moisture content of this unit was calculated between 27.1 to 66.2%.

Soil Unit 2 extended below Soil Unit 1 from approximately 6 metres to 9 metres subsurface. The unit is predominantly composed of medium stiff to very stiff silty clays with traces of sand and isolated gravel. The natural moisture content of Soil Unit 2 is between 20.4 to 44.7%.

Soil Unit 3 is found below Soil Unit 2 extending to average depths of 11 metres in some boreholes and 17 metres in others. The unit consists of very stiff to hard silty clays with slight to frequent remnants of sand, occasional gravel and silty sandy clays. The natural moisture content of Soil Unit 3 varies from 21 to 51%.

The grain size composition of each soil unit was analyzed in the geotechnical investigations at the San Fernando WWTP. The data is presented in Table 5-2. In addition, chemical testing of samples from 3% of the total number of borehole sites were done. This was used to give an indication of the chemical range of subsoils; the following parameters were tested and the ranges were:

- pH 6.87 – 7.94
- Sulphate (%) 0.005 – 0.027
- Chloride (%) 0.033 – 0.274

The groundwater conditions at the borehole sites were also measured by Geotech Associates Limited. Generally, in areas where the elevation of the ground surface was between 3 and -1 metres above sea level (masl) the groundwater level ranged from 0.6 to 4 metres below ground. At sites where the



elevation was between 1.9 and -1.4 masl the observed groundwater level ranged from 1 to 3 metres below the ground surface.

**Table 5-2 Grain Composition of Soil Units**

Grain Size	Soil Unit 1 (%)	Soil Unit 2 (%)	Soil Unit 3 (%)
Gravel	0 – 7.8	0 – 12.8	0 – 14
Sand	1.1 – 23.3	0.6 – 13.8	0.6 – 39.2
Silt	20.7 – 37.1	20.6 – 31.5	15.3 – 29.2
Clay	46.6 – 77.2	51.6 – 78.4	37.5 – 81.5

#### 5.4.2 San Fernando Collection System

The soil investigations within the entire project area were undertaken to identify the geotechnical conditions of the collection system for both environmental and design purposes. The soil types, according to the Soils Map of Trinidad, 1971, fall into two different groups;

- Group B - Soils of the Alluvial Plains and Valleys
- Group C - Soils of the Uplands

There are four different soil classes in these two groups, found within the San Fernando Wastewater Catchment. The most dominant are the Princes Town Clay that fall under Group C, the lithological composition of this soil type is marl with imperfect drainage. Talparo Clays, which are part of Group C, are also encountered in parts of the project area; drainage is typically impeded in this soil and the lithology is mainly clay shale. Another soil class in the San Fernando Area under Group C is the Tarouba Clays which has impeded drainage and the lithological composition is primarily calcareous clay shales. These Group C soil types are generally intermediate upland soils with restricted internal drainage.

The only soil class in the project area belonging to Group B is the Sevilla Clays; this class is found predominantly along the course of the Ciperio River. These are imperfectly drained, deep alluvial soils with restricted internal drainage and have a clay alluvium lithological component.

Sixty boreholes were drilled throughout the catchment, shown in Figure 5-11. Table 5-3 lists the location and area in which these boreholes were sited. The results of the investigation are affixed in **Appendix E.1**.

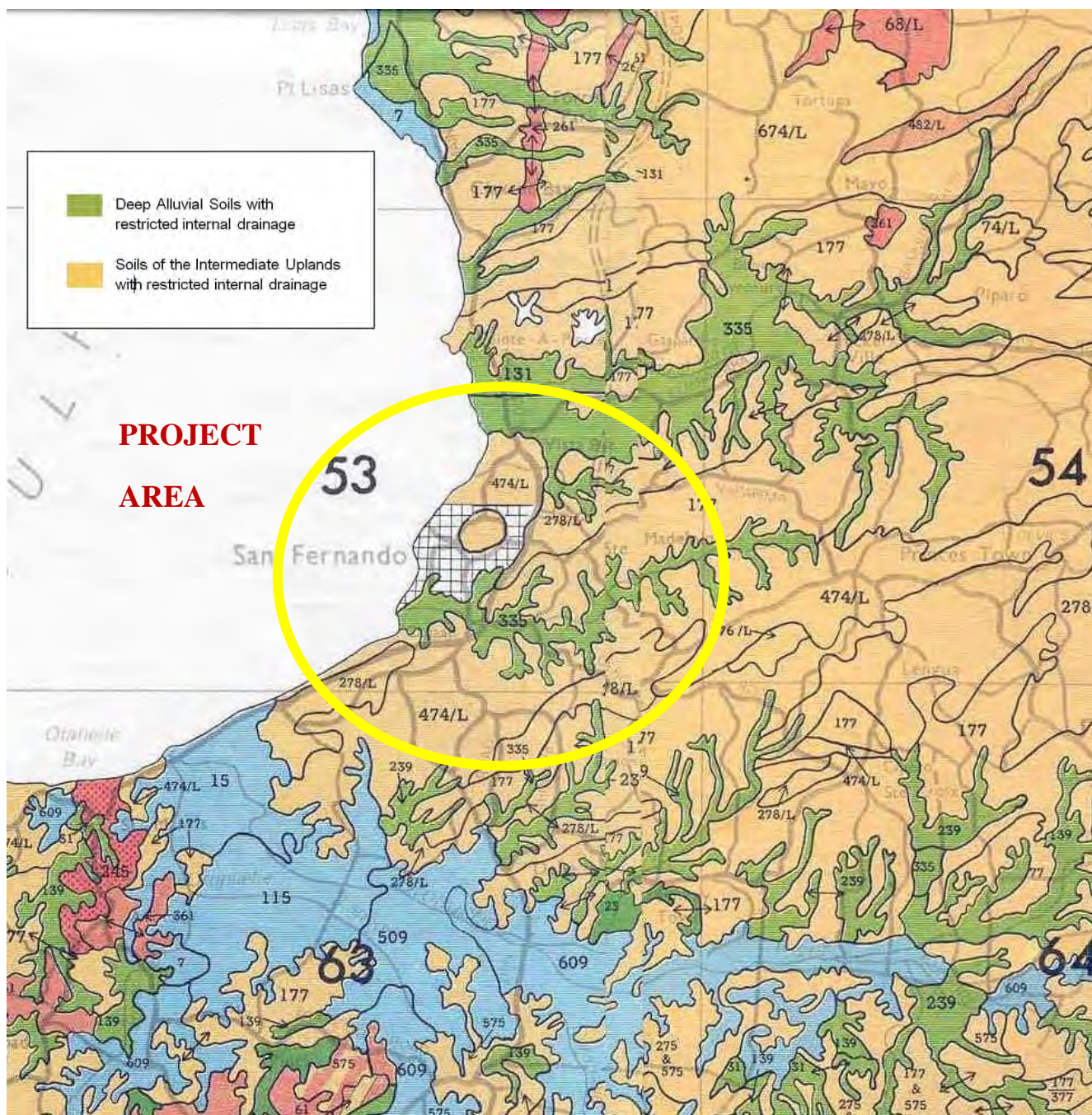


Figure 5-10 Soils Map of Trinidad, 1971 (Lands and Surveys Division)



Figure 5-11 Sites of Soil Investigation within San Fernando Collection System



**Table 5-3 List of Borehole Sites for San Fernando Wastewater Collection System**

Area	Depth	Northing	Easting
WWTP	11.1	1135252	667357
	9.6	1135075	667385
Marabella	5.6	1139058	669717
	5.4	1139041	669584
	5.0	1139098	669486
	4.3	1139169	669279
	5.0	1139169	668997
	6.4	1139210	668897
	3.7	1139155	669078
	6.7	1138958	668925
	9.3	1138628	668860
	11.3	1138409	668768
	8.9	1138196	668623
	Tarouba-Cocoyea	3.6	1137869
6.7		1137577	669975
Pleasantville-Corinth	3.3	1134722	669048
	2.7	1134764	669027
	2.1	1134581	669105
	2.4	1134585	669336
	2.3	1134694	669560
	1.7	1134695	669796
	4.7	1134695	669971
	5.3	1134716	670121
	4.9	1134656	670323
	4.5	1134675	670494
	4.0	1134670	670720
	Green Acres	5.0	1135011
5.0		1134914	668371
San Fernando Central	10.6	1137626	668003
	7.9	1137442	667869
	8.3	1137333	667715
	8.9	1137070	667579
	9.8	1136763	667453
	10.7	1136639	667348
	11.6	1136542	667256
	12.5	1136430	667211
	11.6	1136185	667277
	13.4	1135974	667348
	15.1	1135818	667399

**Table 5-3 List of Borehole Sites for San Fernando Wastewater Collection System (continued)**

Area	Depth	Northing	Easting
San Fernando Central	15.1	1135602	667473
	13.9	1135481	667472
	12.4	1135423	667439
	11.0	1135317	667412
San Fernando South	6.6	1135071	667570
	8.1	1135072	667752
	5.0	1135038	667946
	5.0	1134985	668130
	5.0	1134984	668270
	3.5	1134841	668520
	5.0	1134651	668644
	6.6	1134661	668874
Vistabella	3.787	1138099	669806
	3.395	1138182	669372
	4.227	1137977	669003
	6.277	1137997	668831
	5.973	1138029	668654
	9.533	1137907	668437
	10.312	1137763	668243
	10.312	1137704	668107

Note:\*\*Coordinate datum – Naparima 1955; UTM Zone 20N

## 5.5 Geology

Trinidad is located on the southern end of the Caribbean Plate and is arguably between the Caribbean and South American Plates. The geology of Trinidad is complex and there are many theories behind the intricate details of the faults, formations and their deposition.

Trinidad is divided into five different physiographic regions as depicted in Figure 5-12. The San Fernando Wastewater Catchment is located within the Southern Basin which is a synclinal structure. The geographical expression of this structure is a series of undulating hills and basins.

The geological formations (FM) that comprise the project area are depicted in Figure 5-13 and listed in Table 5-4 in decreasing chronological order. The age of the FMs are based on the stratigraphic chart of Trinidad. J.B. Saunders in 1997 updated the previous geological map of Trinidad which was produced by H.G. Kugler in 1959.

The Naparima Hill Formation according to Saunders, 1997 is what is known as the San Fernando Hill. This FM was deposited in a deep water, low energy environment and is the oldest within the project area but was uplifted due to tectonic activity.

One of the more dominant geological formations in the San Fernando Wastewater Catchment is the Cipero FM. This FM was deposited in a deep water environment after the sedimentation of the San Fernando Formation in the Eocene. An increase in sea level is hypothesized to have caused this shift in depositional environment. The sands of the Upper Cipero Formation are important oil producers.

Another FM covering a large aerial extent is the Nariva Formation. The FM is inferred to have been deposited in a deep water marine environment since the fine-grained sediments are indicative of this setting. The sands of the Nariva FM are one of the oldest oil producers in Trinidad with several petroleum traps both onshore and offshore.

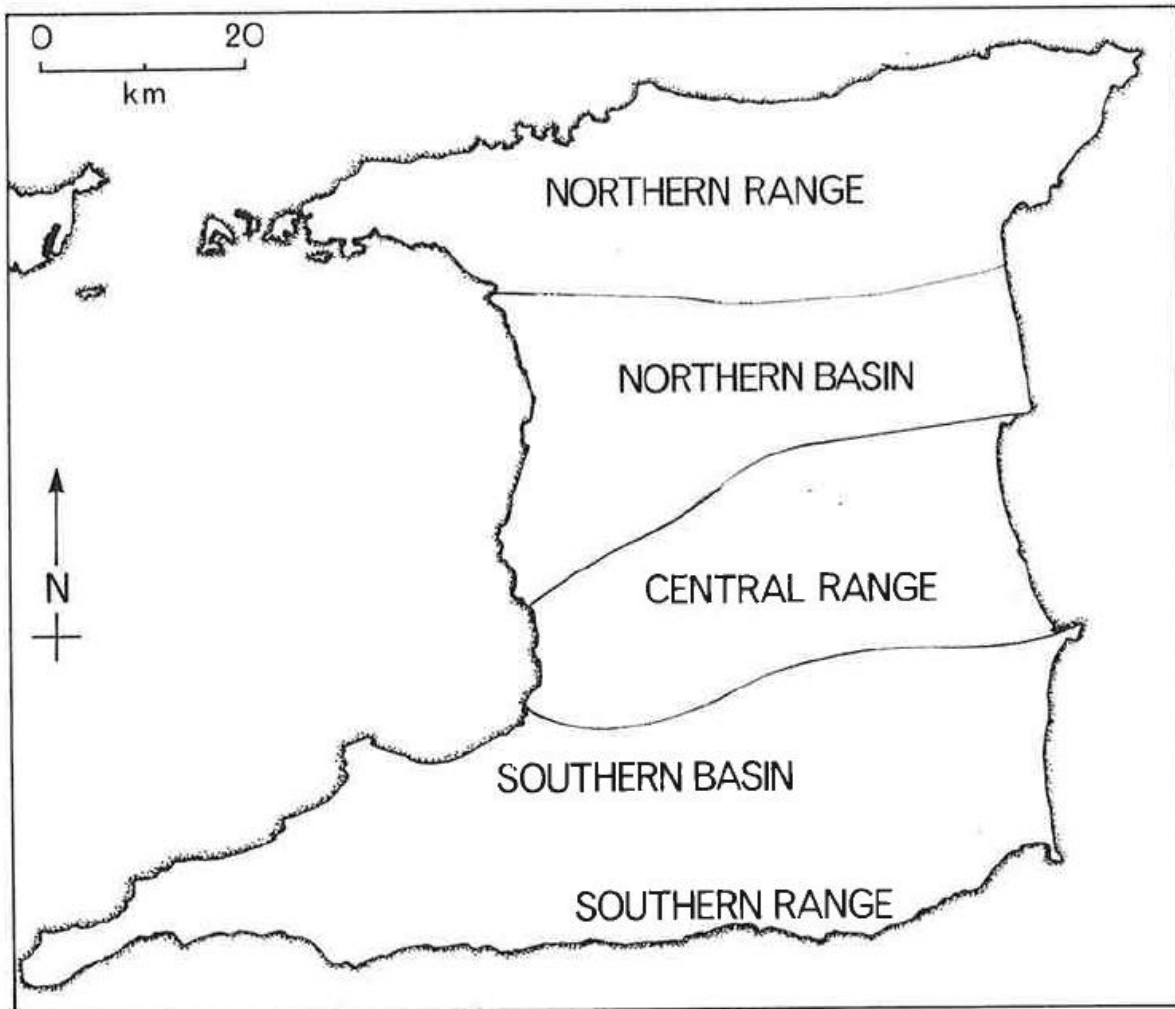


Figure 5-12 Physiographic Regions of Trinidad (Donovan, 1994)

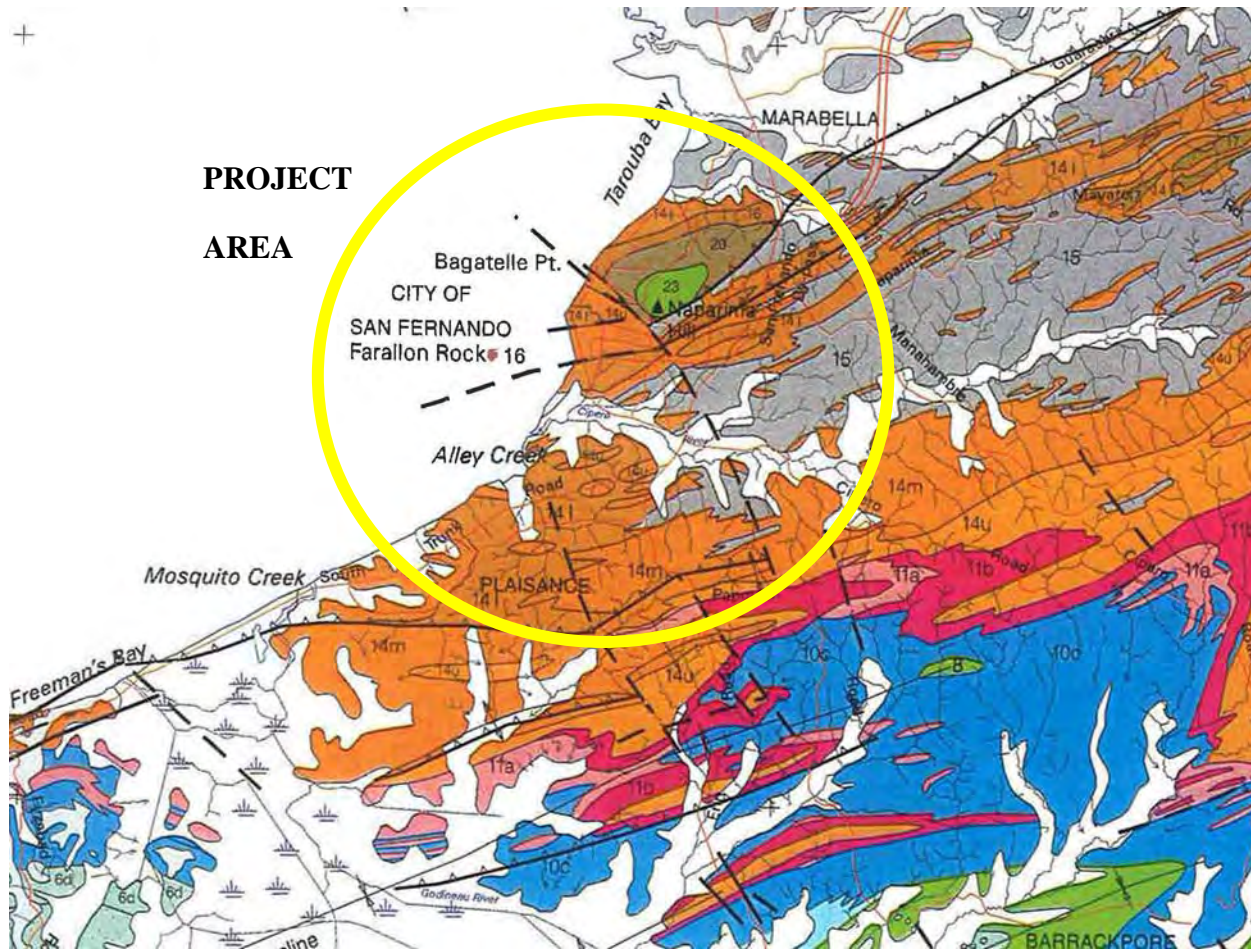


Figure 5-13 Geological Map of Project Area (Saunders, 1997)

Table 5-4 Geological Formation and Sedimentology

Geological Formation	Sedimentology	Age
Naparima Hill FM	Bituminous mudstones and shales, marls, silicified siltstones and mudstones, cherts	Cretaceous
Lizard Springs FM	Stratified marl and calcareous clay	Palaeocene
San Fernando FM	Impure sandstones, silts, glauconitic shales and calcareous foraminiferal clays	Eocene
Cipero FM	Deep water calcareous clays and marls	Miocene
Nariva FM	Mudstones and shales, silts and sands	Miocene
Cedros FM	Blocky clays, fine to coarse-grained sands	Pleistocene





There are many structural features in the Southern Basin which fashioned the nature of the geography of the region. These include the Naparima Fold Belt and the South Trinidad Fault Zone. The structural expression of these faults and folds are clay diaper anticlines, countless petroleum traps and mud volcanism in southern Trinidad. Saunders in his field investigation found two thrust faults within the San Fernando Wastewater Catchment area. One of the faults traverses perpendicular to the San Fernando Bye Pass along the vicinity of Cocoyea into Corinth. Another reverse fault was deduced parallel to the Old Southern Main Road extending perpendicular to Dumfries Road. The topography of the project area is a signature feature of these faults and many others that have not yet been identified.

## 5.6 Topography

The San Fernando Project Area is a series of undulating plains with a series of streams and rivers spread over the landscape. The San Fernando Hill is the highest point within the project area and is approximately 191 masl. The major watercourses in the project area are the Guaracara River, Marabella River, Vistabella River and Cipero River. To some extent these rivers have cut into the plains forming the existing basins and valleys.

The major roadways are aligned to the ridges of the hills in the San Fernando area. Examples of this include; the San Fernando Bye Pass and the Naparima Mayaro Road. Additional major topographical features are the marshlands found at two sites within the project area; at the mouth of the Cipero and Guaracara Rivers. These features represent areas below the mean sea water level. The Oropouche Swamp is located south of the San Fernando Catchment area outside of the project area boundary.

## 5.7 Drainage

The San Fernando project area is located mostly within the Central West Coast Hydrometric Region, with the some of the southern project area within the South Oropouche Hydrometric Region. These hydrometric areas have been divided into watersheds or catchment areas. Within the Central West Coast Hydrometric Region, the Cipero and Guaracara watersheds are within the project area (Genivar, 2009). These watersheds are defined by the major rivers which include the Cipero and Guaracara Rivers. There are also minor rivers within these watersheds including the Marabella, Vistabella, Alley's Creek and some smaller streams, all of which drain west into the Gulf of Paria (Figure 5-14).

The Guaracara Watershed covers a wider extent in comparison to the Cipero Watershed with areas of 121.52 km<sup>2</sup> and 50.68 km<sup>2</sup> respectively (Figure 5-15). The range of the Guaracara Watershed extends over the northern portion of the project area. The Godineau River is located south of the San Fernando Wastewater Catchment area within the South Oropouche Hydrometric Region. Even though this river does not flow through the project area the drains and streams in the southern areas of the wastewater catchment drain into the Godineau River and eventually into the Gulf of Paria (Genivar, 2009).

The new San Fernando WWTP is to be constructed on the site of the existing San Fernando WWTP, north of the Cipero River. River flow and height data of the Cipero River was obtained from WASA's Water Resources Agency (Table 5-5), which was used in the design of the WWTP to avoid flooding.



Figure 5-14 Drainage Features within the San Fernando Wastewater Catchment

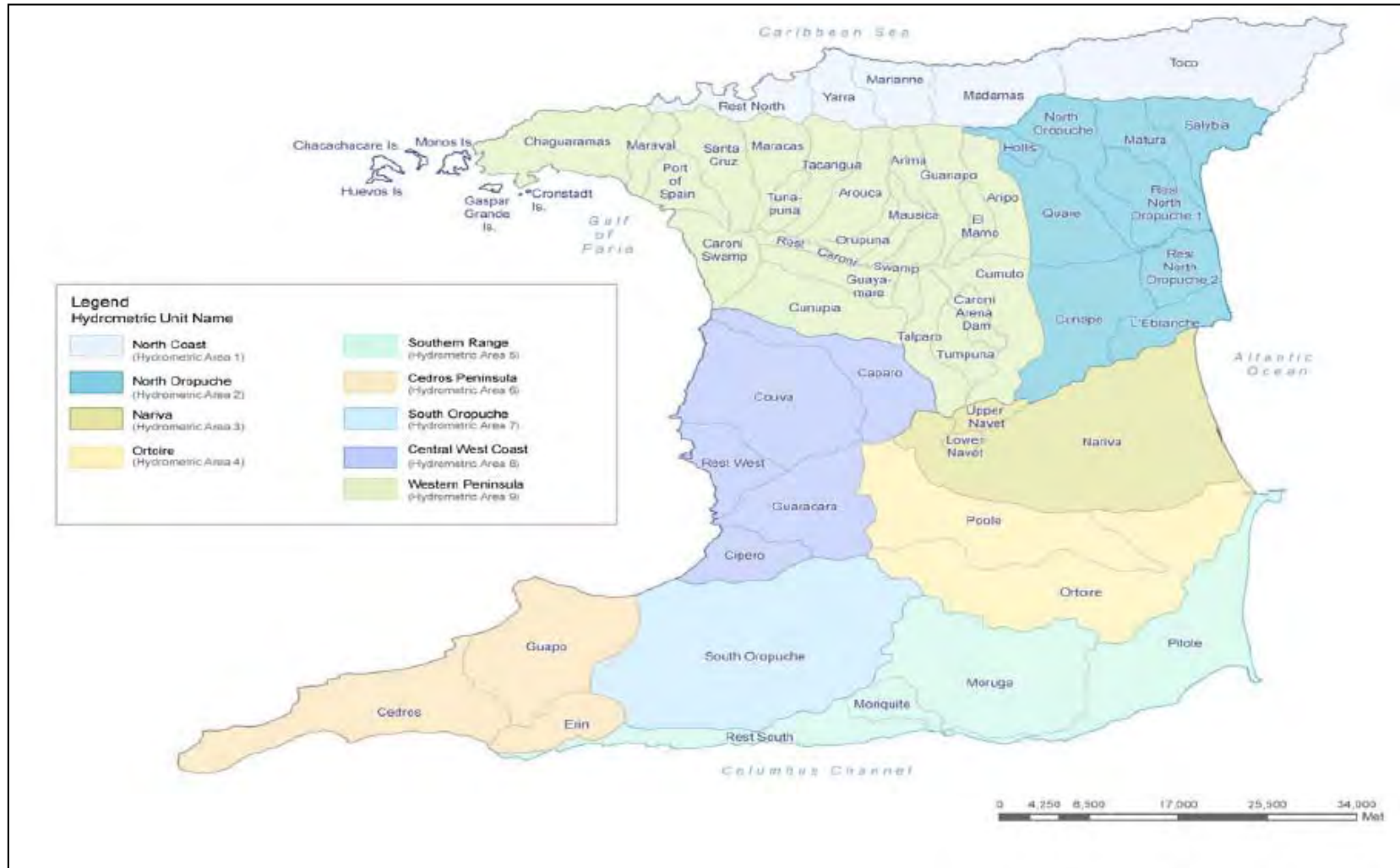


Figure 5-15 Hydrometric Areas and Watersheds of Trinidad (Genivar, 2009)

**Table 5-5 River Flow Data at Cipro River, Station Number 10803 (Water Resources Agency, 2010)**

Year	Annual Minimum Discharge (m <sup>3</sup> /sec)	Annual Maximum Discharge (m <sup>3</sup> /sec)	Instantaneous Peak Discharge (m <sup>3</sup> /sec)	Water Level Maximum (masl)	Water Level Minimum (masl)
1980	0.240	19.911	77.003	-	-
1981	0.000	25.979	-	-	-
1982	0.066	22.800	55.150	-	-
1983	0.002	12.300	48.060	-	-
1984	0.010	26.000	13.6e	-	-
1985	0.008	20.300	96.050	-	-
1986	0.025	20.400	83.240	-	-
1987	0.014	11.700	45.700	-	-
1988	0.035	23.020	88.160	5.140	0.240
1989	0.019	8.396	31.870	3.340	0.200
1990	0.030	26.421	66.590	4.570	0.080
1991	0.025	10.834	36.760	3.550	0.160
1992	0.000	28.048	44.950	5.240	0.240
1993	0.001	31.943	-	5.020	0.380
1994	0.017	8.887	19.260	2.870	0.160
1995	0.000	9.178	44.930	3.960	0.080
1996	0.000	13.582	39.157	-	-
1997	0.008	10.274	27.164	-	-
1998	0.000	18.410	79.440	4.970	-0.050
1999	0.217	12.275	13.667	3.084	0.000
2000	0.174	12.889	26.462	3.872	0.349
2001	0.126	6.647	-	3.779	0.318
2002	0.371	10.066	-	3.751	0.584
2003	0.312	4.994	-	3.369	0.530

Note: e – estimated data

## 5.8 Water Quality

Riverine water sampling was conducted on June 3<sup>rd</sup>, 2009 and October 20<sup>th</sup>, 2009. The rivers sampled included the Guaracara, Marabella, Vistabella, Cipro, and Ally's Creek as depicted in Figure 5-16. Sampling occurred upstream of the project boundary to the east, and downstream close to the Gulf of Paria. Sampling of these downstream points was conducted when the tide was going out in order for the direction of flow in the rivers to be indicative of a downstream sample. The Vistabella and Ally's Creek did not have sufficient quantities of water to allow sampling during the dry season (June 3<sup>rd</sup>,



2009). The downstream sample site for the Ciperó River was located at the eastern end of the existing San Fernando WWTP site, approximately 320 m downstream of the effluent discharge point.

Analysis of temperature, dissolved oxygen (DO) and pH were performed in-situ with calibrated equipment, while laboratory bottles were filled for the remainder of the analysis to be conducted off-site. This laboratory work was conducted by Testmark Laboratories. Calibration certificates and accreditation papers are included in **Appendix D.2**. All laboratory analyses were performed in accordance with the relevant test methods set out in the Standard Methods for the Examination of Water and Wastewater, and the results compared against the permissible limits stipulated for inland watercourses in the Water Pollution Rules, 2001 (as amended).

Results from the sampling are summarized in Table 5-6 to Table 5-10.



Figure 5-16 Sampling Locations for Water Quality Testing



**Table 5-6 Results from Analysis of Water Samples from Guaracara River**

Parameters	EMA Water Pollution Rules 2001 (as amended) 1st Schedule	Inland		Gulf	
		Dry Season	Wet Season	Dry Season	Wet Season
Temperature (°C)*	Max variation of 3°C from ambient	26.74	25.15	31.43	26.79
Dissolved Oxygen (DO) (mg/L)*	<4	3.69	5.44	0.5	3.5
Hydrogen ion (pH)*	Less than 6 or greater than 9	7.91	7.53	8.17	7.49
Five day Biological Oxygen Demand (BOD <sub>5</sub> ) (mg/L)	>10	1.3	4.4	55	3.8
Chemical Oxygen Demand (COD) (mg/L)	>60	8.8	34	380	52
Total Suspended Solids (TSS) (mg/L)	>15	12	402	1,810	38
Ammonia (as N) (mg/L)	>0.01	0.219	0.081	0.907	0.432
Nitrate (as N) (mg/L)	No limit	0.57	0.15	<10	<10
Total Phosphorus (as P) (mg/L)	>0.1	0.383	0.271	4.72	0.162
Total Chromium (Cr) (mg/L)	>0.1	<.001	0.0032	0.0037	0.0056
Dissolved Iron (Fe) (mg/L)	>1.0	0.027	0.509	4.87	0.505
Total Nickel (Ni) (mg/L)	>0.5	0.0043	0.0049	0.016	0.0054
Total Copper (Cu) (mg/L)	>0.01	0.0016	0.0089	0.154	0.038
Total Zinc (Zn) (mg/L)	>0.1	0.0367	0.046	0.0063	0.011
Total Arsenic (As) (mg/L)	>0.01	0.004	0.0015	0.0929	0.0221
Total Cadmium (Cd) (mg/L)	>0.01	<.0001	<.0001	<.0001	<.0001
Total Mercury (Hg) (mg/L)	>0.005	<.0001	<.0001	<.0001	<.0001
Total Lead (Pb) (mg/L)	>0.05	<.001	0.0022	<.001	0.0018
Total Cyanide (as CN-) (mg/L)	>0.01	<0.001	<0.001	<0.001	<0.001
Faecal Coliforms (CFU/100ml)	>100	360	8,000	315	32,000

Note: \* indicates those measurements conducted using in-situ field testing.



**Table 5-7 Results from Analysis of Water Samples from Marabella River**

Parameter	EMA Water Pollution Rules 2001 (as amended) 1st Schedule	Inland		Gulf	
		Dry Season	Wet Season	Dry Season	Wet Season
Temperature (°C)*	Max variation of 3°C from ambient	26.23	24.98	26.01	25.75
Dissolved Oxygen (DO) (mg/L)*	<4	2.98	3.76	0.68	2.07
Hydrogen ion (pH)*	Less than 6 or greater than 9	7.9	7.63	8	7.26
Five day Biological Oxygen Demand (BOD <sub>5</sub> ) (mg/L)	>10	1.3	2.2	110	3.3
Chemical Oxygen Demand (COD) (mg/L)	>60	13	42	65.1	52
Total Suspended Solids (TSS) (mg/L)	>15	15	54	1,020	27
Ammonia (as N) (mg/L)	>0.01	0.54	0.124	7.53	0.747
Nitrate (as N) (mg/L)	No limit	0.27	0.11	<1	<10
Total Phosphorus (as P) (mg/L)	>0.1	0.109	0.219	0.229	0.391
Total Chromium (Cr) (mg/L)	>0.1	<.001	0.0058	0.0043	0.0067
Dissolved Iron (Fe) (mg/L)	>1.0	0.068	0.775	6.2	0.753
Total Nickel (Ni) (mg/L)	>0.5	0.0045	0.0049	0.0104	0.0051
Total Copper (Cu) (mg/L)	>0.01	0.0267	0.0052	0.05	0.0295
Total Zinc (Zn) (mg/L)	>0.1	0.0175	0.0103	0.0211	0.015
Total Arsenic (As) (mg/L)	>0.01	0.0037	0.0025	0.0277	0.0183
Total Cadmium (Cd) (mg/L)	>0.01	<.0001	<.0001	<.0001	<.0001
Total Mercury (Hg) (mg/L)	>0.005	<.0001	<.0001	<.0001	<.0001
Total Lead (Pb) (mg/L)	>0.05	<.001	<.001	0.001	<.001
Total Cyanide (as CN-) (mg/L)	>0.01	<0.001	<0.001	<0.001	<0.001
Faecal Coliforms (CFU/100ml)	>100	8,000	11,000	49,000	46,000

Note: \* indicates those measurements conducted using in-situ field testing.





**Table 5-8 Results from Analysis of Water Samples from Vistabella River**

Parameter	EMA Water Pollution Rules 2001 (as amended) 1st Schedule	Inland	Gulf
		Wet Season	Wet Season
Temperature (°C)*	Max variation of 3°C from ambient	26.38	27.62
Dissolved Oxygen (DO) (mg/L)*	<4	3	0.22
Hydrogen ion (pH)*	Less than 6 or greater than 9	7.43	7.27
Five day Biological Oxygen Demand (BOD <sub>5</sub> ) (mg/L)	>10	5.1	7.7
Chemical Oxygen Demand (COD) (mg/L)	>60	38	79.9
Total Suspended Solids (TSS) (mg/L)	>15	21	20
Ammonia (as N) (mg/L)	>0.01	1.21	2.91
Nitrate (as N) (mg/L)	No limit	0.33	<10
Total Phosphorus (as P) (mg/L)	>0.1	0.489	0.727
Total Residual Chlorine (as Cl <sub>2</sub> ) (mg/L)	0.2		
Total Chromium (Cr) (mg/L)	>0.1	0.005	0.0078
Dissolved Iron (Fe) (mg/L)	>1.0	0.375	0.202
Total Nickel (Ni) (mg/L)	>0.5	0.0039	0.0077
Total Copper (Cu) (mg/L)	>0.01	0.0061	0.056
Total Zinc (Zn) (mg/L)	>0.1	0.0069	0.0094
Total Arsenic (As) (mg/L)	>0.01	0.0028	0.0344
Total Cadmium (Cd) (mg/L)	>0.01	<.0001	<.0001
Total Mercury (Hg) (mg/L)	>0.005	<.0001	0.00013
Total Lead (Pb) (mg/L)	>0.05	<.001	<.001
Total Cyanide (as CN <sup>-</sup> ) (mg/L)	>0.01	<0.001	<0.001
Faecal Coliforms(CFU/100ml)	>100	11,000	>200,000

Note: \* indicates those measurements conducted using in-situ field testing.



**Table 5-9 Results from Analysis of Water Samples from Cipero River**

Parameter	EMA Water Pollution Rules 2001 (as amended) 1st Schedule	Inland		Gulf		Mid-Way
		Dry Season	Wet Season	Dry Season	Wet Season	Wet Season
Temperature (°C)*	Max variation of 3°C from ambient	26.6	26.49	27.58	28.87	27.77
Dissolved Oxygen (DO) (mg/L)*	<4	2.13	4.78	1.08	0.49	0.81
Hydrogen ion (pH)*	Less than 6 or greater than 9	7.46	7.51	7.98	6.78	6.93
Five day Biological Oxygen Demand (BOD <sub>5</sub> ) (mg/L)	>10	170	> 479	43	350	416
Chemical Oxygen Demand (COD) (mg/L)	>60	380	1060	113	799	827
Total Suspended Solids (TSS) (mg/L)	>15	38	69	43	704	67
Ammonia (as N) (mg/L)	>0.01	0.09	0.067	9.01	0.163	0.052
Nitrate (as N) (mg/L)	No limit	<0.1	<0.1	<1	<10	<0.1
Total Phosphorus (as P) (mg/L)	>0.1	0.333	0.137	2.25	1.46	0.148
Total Chromium (Cr) (mg/L)	>0.1	0.0024	0.011	0.0028	0.0112	0.0086
Dissolved Iron (Fe) (mg/L)	>1.0	3.66	1.2	1.6	9.47	1.9
Total Nickel (Ni) (mg/L)	>0.5	0.0037	0.005	0.0078	0.0089	0.0049
Total Copper (Cu) (mg/L)	>0.01	0.0102	0.0088	0.0438	0.0394	0.008
Total Zinc (Zn) (mg/L)	>0.1	0.0148	0.0173	0.0314	0.0206	0.0155
Total Arsenic (As) (mg/L)	>0.01	0.0041	0.003	0.0257	0.0133	0.0029
Total Cadmium (Cd) (mg/L)	>0.01	<.0001	<.0001	<.0001	<.0001	<.0001
Total Mercury (Hg) (mg/L)	>0.005	<.0001	<.0001	<.0001	<.0001	<.0001
Total Lead (Pb) (mg/L)	>0.05	<.001	<.001	<.001	<.001	<.001
Total Cyanide (as CN <sup>-</sup> ) (mg/L)	>0.01	<0.001	<0.001	<0.001	<0.001	<0.001
Faecal Coliforms (CFU/100ml)	>100	179,000	198,000	120,000	>200,000	>200,000

Note: \* indicates those measurements conducted using in-situ field testing.

**Table 5-10 Results from Analysis of Water Samples from Ally's Creek**

Parameter	EMA Water Pollution Rules 2001 (as amended) 1st Schedule	Wet Season
Temperature (°C)*	Max variation of 3°C from ambient	29.6
Dissolved Oxygen (DO) (mg/L)*	<4	4.35
Hydrogen ion (pH)*	Less than 6 or greater than 9	7.72
Five day Biological Oxygen Demand (BOD <sub>5</sub> ) (mg/L)	>10	22
Chemical Oxygen Demand (COD) (mg/L)	>60	38
Total Suspended Solids (TSS) (mg/L)	>15	10
Ammonia (as N) (mg/L)	>0.01	2.34
Nitrate (as N) (mg/L)	No limit	0.22
Total Phosphorus (as P) (mg/L)	>0.1	0.801
Total Chromium (Cr) (mg/L)	>0.1	0.0049
Dissolved Iron (Fe) (mg/L)	>1.0	0.269
Total Nickel (Ni) (mg/L)	>0.5	0.0037
Total Copper (Cu) (mg/L)	>0.01	0.0048
Total Zinc (Zn) (mg/L)	>0.1	0.0297
Total Arsenic (As) (mg/L)	>0.01	0.0028
Total Cadmium (Cd) (mg/L)	>0.01	<.0001
Total Mercury (Hg) (mg/L)	>0.005	<.0001
Total Lead (Pb) (mg/L)	>0.05	<.001
Total Cyanide (as CN <sup>-</sup> ) (mg/L)	>0.01	0.0118
Faecal Coliforms (CFU/ 100ml)	>100	112000

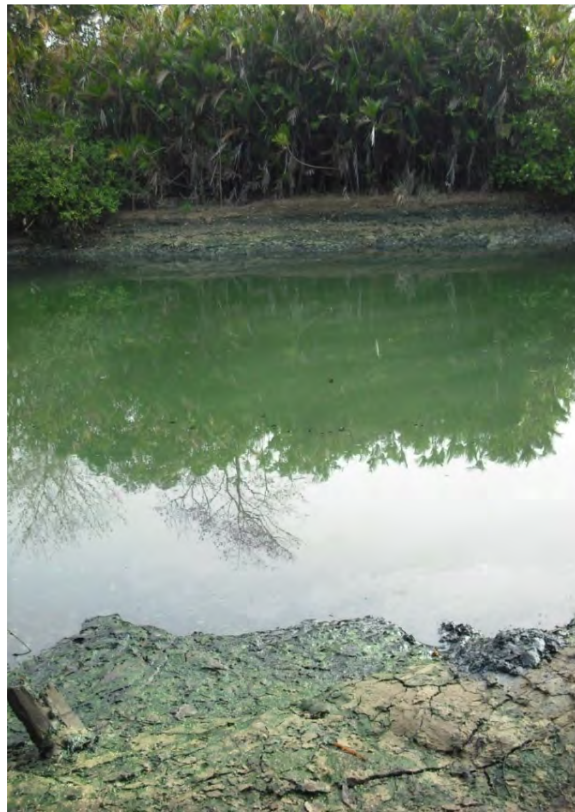
Note: \* indicates those measurements conducted using in-situ field testing.

Photos illustrating the sampling locations accessed included as Figure 5-17 through Figure 5-25.

In order to determine the effect on the river quality as it passes through the San Fernando catchment, the upstream (inland) samples have been compared to the to the downstream (gulf) samples. While the Cipro River BOD<sub>5</sub> and COD values showed an increase in quality (as demonstrated by a decrease in the parameter value) in both the wet and dry season sampling, there were several parameters that decreased in quality, in all rivers sampled. These parameters have been highlighted in Table 5-11.



**Figure 5-17 Guaracara River Upstream Sampling Location**



**Figure 5-18 Guaracara River Downstream Sampling Location**



**Figure 5-19 Marabella River Upstream Sampling Location**



**Figure 5-20 Marabella River Gulf Sampling Location**



**Figure 5-21 Vistabella River Upstream Sampling Location**



**Figure 5-22 Vistabella River Downstream Sample Location**



**Figure 5-23 Ciperu River Upstream Sampling Location**



**Figure 5-24 Ciperu River Downstream Sampling Location**

**Figure 5-25 Ally's Creek Sampling Location****Table 5-11 Water Quality Parameters That Decreased in Quality within the Catchment**

Guaracara River	Marabella River	Vistabella River	Cipero River
Dissolved Oxygen	Dissolved Oxygen	Dissolved Oxygen	Dissolved Oxygen
BOD <sub>5</sub>	BOD <sub>5</sub>	BOD <sub>5</sub>	Ammonia
COD	COD	COD	Total Phosphorus
TSS	TSS	Ammonia	Faecal Coliforms
Ammonia	Ammonia	Faecal Coliforms	
Total Phosphorus	Total Phosphorus		
Dissolved Iron	Dissolved Iron		
Total Copper	Total Copper		
Faecal Coliforms	Total Arsenic		
	Faecal Coliforms		

A description of these parameters and suggestions at how they are appearing in the river systems follows:

### 5.8.1 Faecal Coliforms

Coliform bacteria are a key indicator commonly used to indicate suitability of water for domestic, recreational, or other uses. The presence of these organisms in water is a good indication of pollution arising from wastes of humans, farm animals, and soil erosion. Faecal Coliforms are a subset of the total Coliform group, and refer to the Coliform bacteria that originate from human faeces or other





warm-blooded animals. Typical compositions of untreated domestic wastewater will have between 1,000 and 1,000,000 CFU/100 ml faecal coliforms (Metcalf, 2003).

All water quality results indicate high levels of Faecal Coliforms at all sites, which indicates that raw sewage is entering the river systems, and increasing as it passes through the San Fernando Catchment. As a result of these elevated bacteria levels, these rivers are not fit for recreational purposes, when compared to the:

- First Schedule of the EMA Water Pollution Rules 2001 (as amended) where a pollutant is defined >100 count/100ml;
- Canadian Recreational Water Quality Guidelines (Minister of National Health and Welfare, 1992) where > 2000 E.Coli<sup>1</sup> /L is considered unsafe for recreational use.

### 5.8.2 BOD<sub>5</sub> and COD

Biochemical Oxygen Demand (BOD) and Chemical Oxygen Demand (COD) are parameters used as general indicators of water quality. BOD measures the oxygen demand that biological organisms in the water exert in the biological oxidation of organic matter in a sample. BOD<sub>5</sub> is a standard test conducted over a 5 day incubation period. COD measures the amount of oxygen used in the chemical oxidation of organic matter in a sample.

High BOD and COD values indicate that there are large populations of microorganisms, and organic matter in the water. As the oxygen demand is high, this usually correlates with low dissolved oxygen levels.

Untreated domestic, industrial and sewage effluents will result in high BOD and COD values.

### 5.8.3 Dissolved Oxygen

Dissolved Oxygen (DO) can be used as an indicator of the health of a river system. Adequate dissolved oxygen levels in water can support aerobic life forms, however if the DO levels drop, the aquatic life is put under stress. High BOD and COD may reduce dissolved oxygen levels. As water temperature increases, the saturation point (DO capacity) decreases.

### 5.8.4 Total Suspended Solids

Total suspended solids (TSS) are all materials, both organic and inorganic which are suspended in the water, including particulate matter, such as silt, clay, and microscopic organisms. Suspended solids can result from erosion, algae growth, or discharges of untreated wastewater. Water high in TSS may have increased temperatures and organic matter, and therefore lower DO, which increases aquatic stresses.

### 5.8.5 Ammonia

Ammonia (NH<sub>3</sub>) is the principal form of toxic ammonia. Wilkes University reports that it has been reported toxic to fresh water organisms at concentrations ranging from 0.53 to 22.8 mg/L, affecting

---

<sup>1</sup> When experience has shown that greater than 90 percent of the fecal coliforms are E.Coli, either fecal coliforms or E.Coli may be determined.



hatching and growth rates. In humans, toxic concentrations may cause loss of equilibrium, convulsions, coma, and death. (Wilkes University, Environmental Engineering and Earth Science Department) The quality of water may be affected by Ammonia's presence. Ammonia is used in fertilizers; animal feed production, and may originate from sewage and the degradation of organic nitrogen materials. In the case of fertilizers and wastes containing inorganic and organic nitrogen, decomposition into ammonia usually occurs first. This increase in ammonia in the San Fernando area is expected to occur because of the 'grey water' connections, and other improperly treated sewage entering the river systems.

#### 5.8.6 Total Phosphorus

Phosphorus is an essential element for plant growth and is an abundant mineral found in humans. It is found in fertilizers and some detergents. When erosion occurs, soil particles that contain phosphorus will be eventually released into the water streams. In the environment, phosphorus, in combination with nitrogen, can promote algae blooms.

#### 5.8.7 Metals

Data indicate that dissolved iron, total copper, and total arsenic concentrations increased in the project area. These metals are all naturally occurring in the environment. Low levels of Copper and Iron are usually found in unpolluted surface waters. High levels of copper may be attributed to pesticides, fungicides, feed additives and disinfectants. Iron is used as a construction material, in pipes, in pigments of paints and plastics, and in food colours. Inorganic arsenic occurs naturally in soil and in many kinds of rock, especially in minerals and ore that contains copper or lead.

### 5.9 Biological Environment

The natural ecology of the study area has long ago been altered through a range of anthropogenic activities, primarily sugar cane cultivation, residential development, and quarrying activities at San Fernando Hill. Few natural areas remain. Field studies were conducted on the biological environment in October and November 2009. These studies included flora, aquatic fauna and terrestrial vertebrates. Historical data on the area was also collected to supplement this data.

A land use map for the San Fernando catchment area was established as a means of categorizing natural and artificial habitats.

#### 5.9.1 Land Use of Project Area

A draft land use map was prepared based on satellite images from GoogleEarth™, (© 2007), the 1:25000 topographic map (Lands and Surveys Division, Port of Spain, Trinidad. Sheet No. 53) and a map of proposed developments which was developed by AECOM based on data acquisition from companies, agencies, and field reconnaissance.

The resolution of the satellite image was such that individual houses and trees could be easily recognised as could waterways and ponds. Based on the satellite image the land use was classified into three main categories and an additional six sub-or intermediate categories.



- **Urban Development** – This category includes high density housing, commercial and industrial areas. The image shows almost continuous roofs and buildings
- **Low vegetation with scrub and/or agriculture.** – Such areas are characterised by generally low vegetation with few scattered trees and no structures. **Abandoned sugarcane** fields could be generally identified by their uniform appearance. Some sugarcane may persist in lands not classified as such. Road verges and wasteland also fall into this basic category.
- **Forested areas** - Including mangrove woodland, Riparian forest, silviculture and secondary forest. **Mangrove woodland** was identified by its location on the coast adjacent to river mouths, and narrow strips of trees bordering watercourses were classified as **Riparian vegetation**. Other areas of tree cover were visited to determine their composition.

An intermediate category of **low density housing and agriculture** was assigned to lands where the houses were further apart and small agricultural plots were visible on the image, or seen during field visits.

An overlay of **proposed developments** was applied to the map resulting in an eighth land use category. This included developments at several stages of completion from land clearing to completed structures.

Other features relevant to wildlife include mudflats or sandbars associated with river mouths, the San Fernando Wharf and fishing depot and two National Parks, San Fernando Hill and Palmiste Park.

The initial land use map was verified by two observers, G. White and P. Comeau who conducted field visits over five days at 45 locations within the study area and an additional 10 locations in the wider area. Dates and locations are provided in **Appendix D.3**, G. White's report, Table 1. During these visits the land use was noted, photographed and, when necessary, the land use map was clarified or amended.

The final land use categories (White, 2009) are presented in Figure 5-26 and tabulated in Table 5-13.

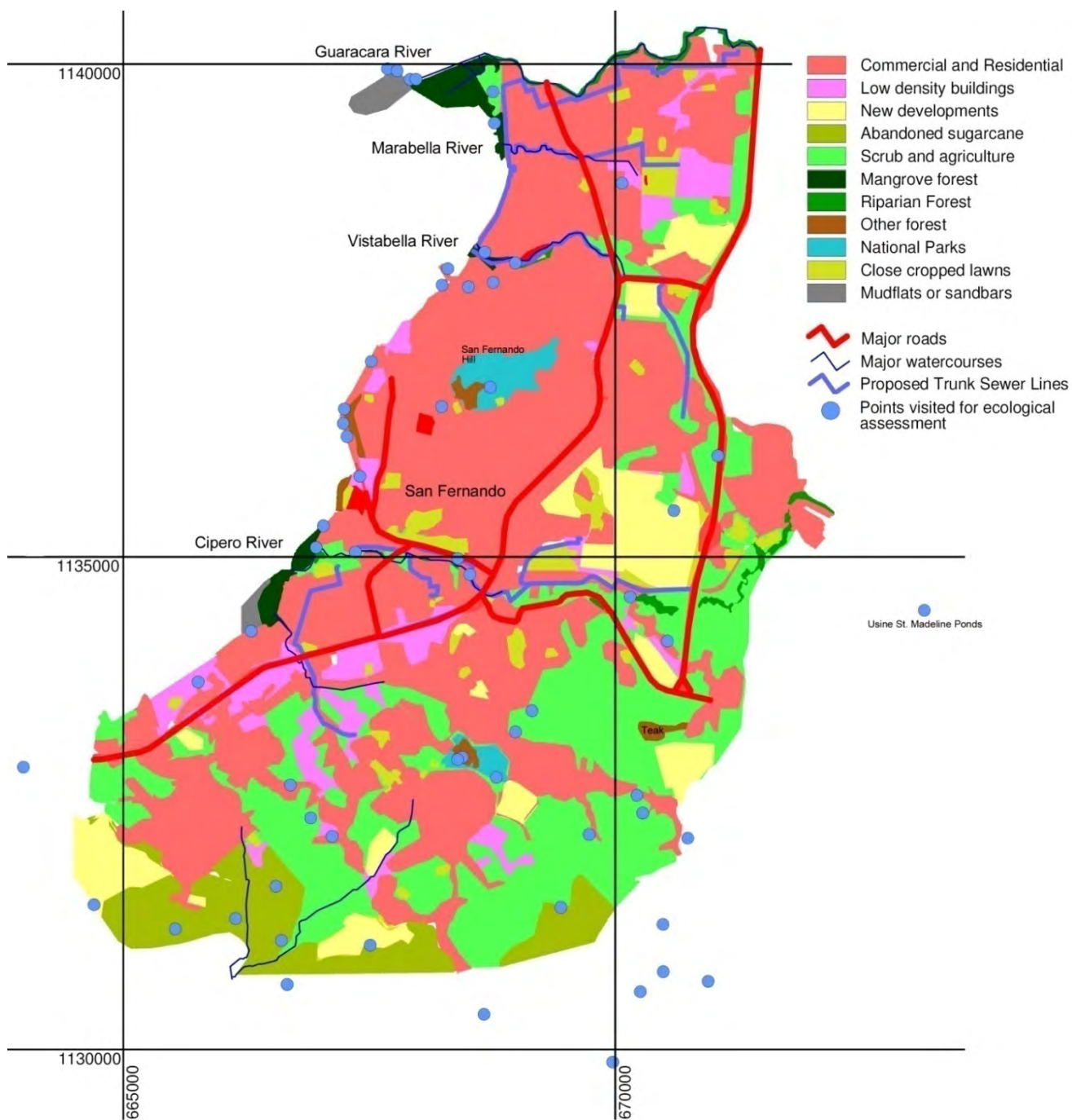


Figure 5-26 Land Use in San Fernando Wastewater Catchment

**Table 5-12 Land Use Categories and Area in San Fernando Wastewater Catchment**

Land Use Category	Area (km <sup>2</sup> )	Percentage of Study Area (%)
Commercial and Residential	8.07	49
Low Density Buildings	0.88	5
New Developments	1.16	7
Abandoned Sugarcane	0.99	6
Scrub and Agriculture	3.63	22
Mangrove Forest	0.21	1
Riparian Forest	0.16	1
National Parks	0.21	1
Close Cropped Lawns	0.49	3
Other	0.8	4
TOTAL	16.6	100

## 5.10 Flora

The field work for this study was carried out at 45 locations within the project area and 10 additional locations in its environs. The report on the flora field work, in its entirety is included in **Appendix D.4**, with the salient points summarized below.

Several centuries ago, the study area was covered by three native forest communities; Crappo-Guatecare-Cocorite, Acurel-Moussara-Carat, and Mora (Marshall, 1934) (Beard, 1946). Today, the only natural remnants are the mangrove trees along the sea shore and the riparian mixed forest further inland both inside and outside of the project boundaries.

The number of observed species has been divided into habitats, as seen in Table 5-13. The recognized habitats observed in this study formed a complex mosaic of plant communities either isolated in small patches, contiguous in others, or as distinctive as the mangrove ecosystem. The flora representation ranged from herbaceous grasses and sedges, common shrubby species such as 'black sage', tree species including palms, exotic fruit trees, introduced timber species for silviculture (teak, cedar, and mahogany), and remnants of native species such as the Silk Cotton tree near the visitor's car park at the San Fernando Boat Club.

**Table 5-13 Observed Habitats and Flora Species Observed**

Habitat	Percentage of Project Area	Species Observed	Comments
Urban Development	49	57	104 species originally recorded by Beard when this project area was originally forest.
Low Vegetation with Scrub and Agriculture	22	57	
Abandoned Sugarcane	6	6	Mainly grasses
Mangrove Woodland	1	17	
Riparian Forest	1	7	Tree species
Silviculture or National Parks	1	5	Dominant tree species included Teak, Samaan, Cedar, Palmist, and Mahogany
Secondary Forest	<3	30	
Road Verges and Wasteland	<3	-	
Low Density Housing and Agriculture	5	6	Dominant species
Proposed Housing Developments	7	-	Mostly barren or sparsely vegetated with several common weeds

As far as possible, the Mangrove Woodland, Riparian Forest and giant Silk Cotton tree should be preserved for future generations to enjoy the diversity offered by these natural habitats or native species. The San Fernando Hill and Palmiste Park were stripped of their natural vegetation but demonstrate good examples of restoration and mitigation of degraded landscapes.

## 5.11 Fauna

### 5.11.1.1 Sites Visited

Terrestrial fauna field visits were conducted over 5 days at 45 locations within the study area, and 10 locations in the wider area. Dates and locations are provided in Figure 5-27.

**Figure 5-27 Dates and Locations of Sites Visited for Terrestrial Fauna Study**

07/10/2009	08/10/2009	13/10/2009	14/10/2009	22/10/2009
670941, 1130692	668729, 1136722	668791, 1132762	668756, 1139721	667685, 1139953
670254, 1130587	667520, 1136983	668445, 1132965	668772, 1139402	667783, 1139934
670485, 1130790	673138, 1134457	668397, 1132942	668675, 1138092	667916, 1139848
670483, 1131270		667122, 1132162	668984, 1137983	667975, 1139848
670734, 1132145		666907, 1132351	668507, 1137739	668235, 1136524
670218, 1132581		666699, 1132684	668298, 1137924	667275, 1136220
670277, 1132400		664705, 1131470	668239, 1137758	667236, 1136354
669972, 1129872		665529, 1131224	668760, 1137785	667246, 1136501
669445, 1131442		666143, 1131330	670068, 1138792	667405, 1135817
669733, 1132183		666552, 1131656		668398, 1134985
669153, 1133438		666607, 1131106		668521, 1134820
668984, 1133224		666666, 1130660		670148, 1134594
666301, 1134246		667510, 1131059		670528, 1134145
663989, 1132866		668665, 1130357		670594, 1135469
665762, 1133731				
667360, 1135047				
666960, 1135095				
667034, 1135315				
671040, 1136026				

Note: Units presented: mE, mN. UTM Zone 20-n. Original coordinates based on Naparima BWI datum and re-registered manually to Naparima 1955.

Specific sites of interest visited for terrestrial fauna observation included:

- Mudflats at Bel Air.
- Boatyard just south of the Vistabella River.
- Mangrove forest around the Guaracara River.
- Freshwater ponds at Usine St. Madeline.
- Ciperó River.
- Forested areas at San Fernando Hill.
- Forested areas at Palmiste Park.

Figures of the some of these sites visited are observed in Figure 5-28 and Figure 5-29.



**Figure 5-28 Cipero River in Concrete Channel at Grid Reference 668521mE, 1134820mN**



**Figure 5-29 Cipero River at Grid Reference 670148mE, 1134594mN**





**Figure 5-30 Mangrove Woodland North of the Guaracara River Accessed via Point-a-Pierre**



**Figure 5-31 Mangrove Woodland South of Guaracara River Mouth**



**Figure 5-32 Mudflats at the Mouth of the Cipro River. Viewed from Bel-Air 666301mE, 1134246mN**



**Figure 5-33 Mudflats at the Mouth of the Vistabella River. Viewed from Boatyard at 668298mE, 1137924mN**

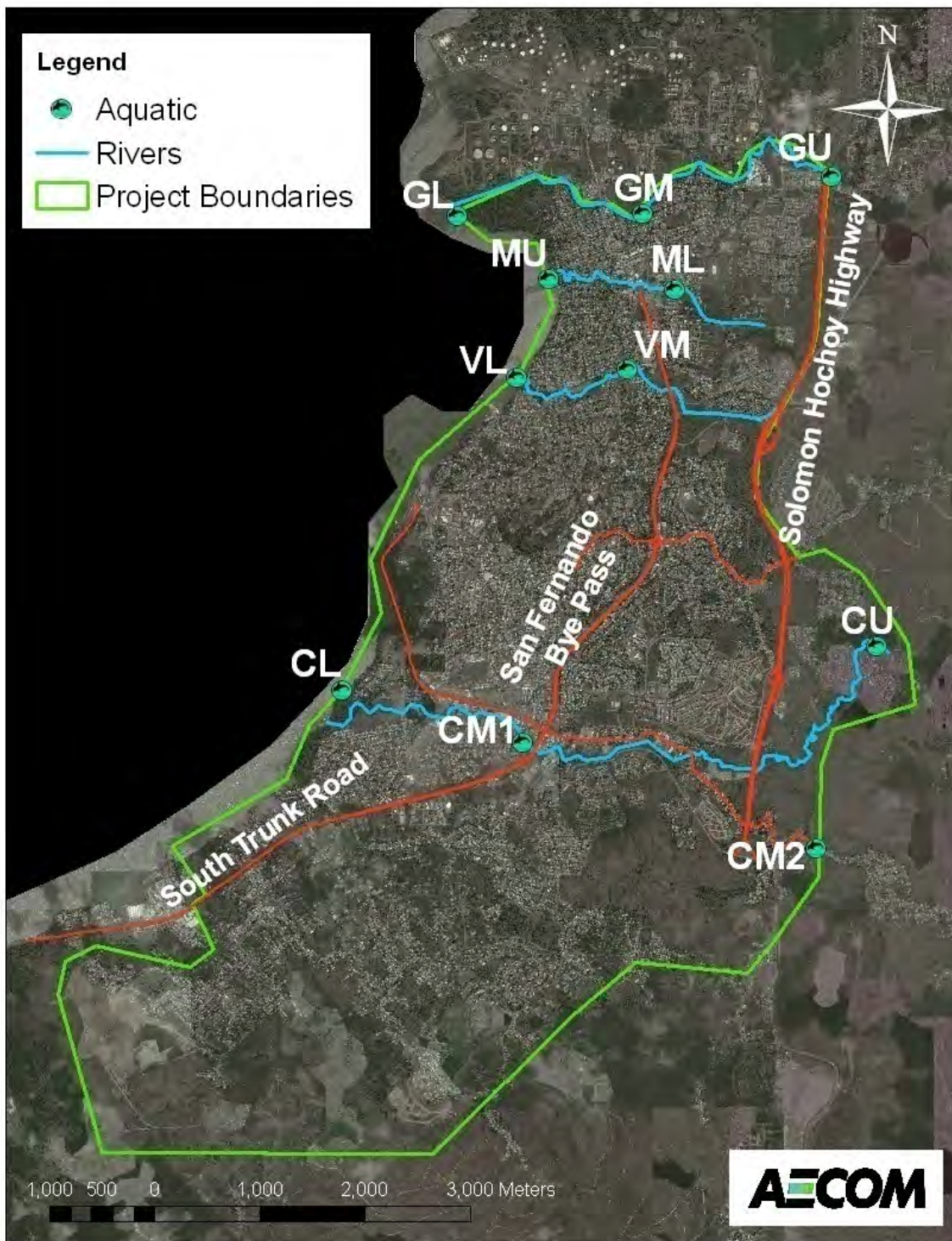


Aquatic fauna field visits were conducted at 13 sample sites in October and November 2009. Two sampling stations were established along the Marabella and Vistabella Rivers, three along Guaracara River and, four along the Ciperó River. Each station represented appropriate segments of the lower, middle and upper courses of the respective river. GPS coordinates of the sites are listed in Table 5-14, and visually displayed in Figure 5-34.

**Table 5-14 Locations Sampled for Aquatic Fauna Study**

Sample Station Name	Sample Station Code	GPS Coordinates	
		Easting	Northing
Cipero Upper	CU	0672327	1135600
Cipero Middle 1	CM1	0668560	1134710
Cipero Middle 2	CM2	0671586	1135040
Cipero Lower	CL	0666834	1135199
Marabella Upper	MU	0670008	1139012
Marabella Lower	ML	0668804	1139119
Vistabella Middle	VM	0669559	1138262
Vistabella Lower	VL	0668506	1138181
Guaracara Upper	GU	0671499	1140088
Guaracara Middle	GM	0669699	1139736
Guaracara Lower	GL	0667941	1139715
Godineau Middle	GoM	0661903	1131179
Godineau Lower	GoL	0661449	1131676

Note: Coordinates based on UTM Zone 20N, WGS 1984



\*\*Note: C- Ciperó River, G – Guaracara River, M- Marabella River, V- Vistabella River U – Upper, M – Middle, L – Lower

**Figure 5-34 Sampling Locations for Aquatic Survey**



### 5.11.1.2 Historical Likely Species

The expected fauna (based upon literature review) of the study area is presented in this section. In the case of the birds the land use categories in which they are expected has been identified. For the other classes a general list is provided.

The list of Amphibians and Reptiles potentially in the study area (Table 5-15) includes 64 species. This list is somewhat speculative given the uncertain abundance and distribution of many of these species in Trinidad.

The list of bird species potentially in the study area (Table 5-16) includes 174 of the 444 species recorded from Trinidad. The highest number of species (120) is likely to occur in the coastal environments. 101 species are listed for the Scrub and Agriculture of which 41 species may be found in the urban areas. Of the 174 species 115 are resident in Trinidad and a further 7 regularly breed. Regular seasonal migration from the north or south is exhibited by 51 species. The migrating species mainly comprise seabirds and shorebirds that utilize the coastal environment.

Within the study area there are potentially 29 mammals (Table 5-17), inclusive of 19 Bat species. This is a low proportion of the mammals of Trinidad as is expected for such an area with little natural habitat. The Silky or Two-toed Anteater, *Cyclopes didactylus* may be present as well since there is a likely population in the Godineau Swamp to the south. The Agouti, *Dasyprocta agouti* is also included on the list as there is a remote possibility of a small population in the forest or residential areas around San Fernando Hill.

The larger rivers within the study area have been well surveyed over the years and are known to support a great diversity of aquatic fauna. Table 5-18 provides aquatic fauna species identified within the study area during historical surveys.

For all taxa, additional species are possible since rare species have not been included unless they have been recorded from the area. A list of butterflies likely to occur in the study area (Table 5-19) includes 12 families, with 62 total species. This list excludes the Family HesperIIDae and those species which tend to be restricted to the north or south of Trinidad.



**Table 5-15 Amphibians and Reptiles Which May be Expected Within San Fernando and Environs**

Family	Order	Habitat & Abundance		Residential	Scrub &* Agriculture	Mangrove
	<b>Order Anura</b>					
Brachycephalidae	<i>Eleutherodactylus urichi</i>	RE	C		X	
Bufonidae	<i>Rhinella beebei</i>	S	C	X	X	
	<i>Rhinella marinus</i>	RES	C	X	X	X
Hylidae	<i>Dendropsophus microcephala misera</i>	S	FC	X	X	
	<i>Dendropsophus minutes</i>	RES	FC		X	
	<i>Hypsiboas crepitans</i>	ES	C	X	X	
	<i>Hypsiboas geographicus</i>	RE	FC		X	
	<i>Hypsiboas punctata</i>	RES	FC		X	
	<i>Phyllomedusa trinitatis</i>	RES	FC		X	
	<i>Pseudis paradoxa caribensis</i>	S-Aq			X	
	<i>Scinax rubra</i>	S	FC	X	X	
	<i>Sphaenorhynchus lacteus</i>	ES	FC		X	
	<i>Trachycephalus venulosus</i>	ES	FC		X	
Leptodactylidae	<i>Leptodactylus bolivianus</i>	S	FC		X	
	<i>Loptodactylus fuscus</i>	S	C	X	X	
	<i>Leptodactylus hylaedactyla</i>	RE			Possible	
	<i>Loptodactylus validus</i>	RES	R	X	X	
Leiuperidae	<i>Engystomops pustulosus</i>	S	C	X	X	
Microhylidae	<i>Elachistocleis ovalis</i>	S	FC		Possible	
	<b>Order Chelonia</b>					
Geoemyidae	<i>Rhinoclemmys punctularia punctularia</i>	RES Aq	C		X	
Kinosternidae	<i>Kinosternon scorpioides scorpioides</i>	RES Aq	C		X	
	<b>Order Crocodylia</b>					
Alligatoridae	<i>Caiman crocodilus crocodiles</i>	RES Aq	C		X	X
	<b>Order Squamata: Suborder Sauria</b>					
Amphisbaenidae	<i>Amphisbaena alba</i>	RE	UC			
	<i>Amphisbaena fuliginosa fuliginosa</i>	RES	UC		X	
Gekkonidae	<i>Gonatodes vittatus vittatus</i>	ES	C	X	X	
	<i>Hemidactylus mabouia</i>	U	C	X	X	
	<i>Hemidactylus palaichthus</i>	ES		X	X	



**Table 5-15 Amphibians and Reptiles Which May be Expected Within San Fernando and Environs (continued)**

Family	Order	Habitat & Abundance		Residential	Scrub &* Agriculture	Mangrove
	<i>Sphaerodactylus molei</i>	E	UC	X	X	
	<i>Thecadactylus rapicauda</i>	RES	UC	X	X	
Gymnophthalmidae	<i>Bachia heteropa trinitatis</i>	RE	UC	X	X	
	<i>Gymnophthalmus underwoodi</i>	ES	C			
Iguanidae	<i>Iguana iguana</i>	RES	C	X	X	
Polycrotidae	<i>Anolis aeneus</i>	I,U	C			
	<i>Anolis trinitatis</i>	I,U	R	X		
	<i>Polychrus marmoratus</i>	E	C	X	X	
Scincisae	<i>Mabuya nigropunctata</i>	RE	UC	X	X	
Teiidae	<i>Ameiva ameiva</i>	RES	C	X	X	
	<i>Kentropyx striatus</i>	ES	UC		X	X
	<i>Tupinambis teguixin</i>	RES	C		X	
	<b>Order Squamata: Suborder Serpentes</b>					
Boidae	<i>Boa constrictor constrictor</i>	RES	C		X	
	<i>Corallus ruschbergerii</i>	ES	FC	X	X	X
	<i>Epicrates cenchria maurus</i>	ES	FC		X	
	<i>Eunectes murinus</i>	RES-Aq	FC		X	
Colubridae	<i>Chironius carinatus</i>	RE	FC		X	
	<i>Leptophis ahaetulla coeruleodorsus</i>	RE	C	X	X	
	<i>Mastigodryas boddaerti dunni</i>	ES	C		X	
	<i>Oxybelis aeneus</i>	RES	C	X	X	
Dipsadidae	<i>Attractus trilineatus</i>	RES	C	X	X	
	<i>Dipsas variegata trinitatis</i>	RE	UC		X	
	<i>Leptodeira annulata ashmeadi</i>	RES	C	X	X	
	<i>Ninia atrata</i>	RES	C		X	
	<i>Sibon nebulata nebulata</i>	RES	C	X	X	
Xenodontinae	<i>Clelia clelia clelia</i>	RES	UC			
	<i>Helicops angulatus</i>	RE	FC		X	
	<i>Hydrops triangularis neglectus</i>	RES-Aq	FC		X	X
	<i>Liophis cobella cobella</i>	RES-Aq	C		X	X



**Table 5-15 Amphibians and Reptiles Which May be Expected Within San Fernando and Environs (continued)**

Family	Order	Habitat & Abundance		Residential	Scrub &* Agriculture	Mangrove
	<i>Liophis melanotus nesos</i>	ES	C	X	X	
	<i>Liophis reginae zweifeli</i>	RE	UC	X	X	
	<i>Oxyrhopus petola petola</i>	RES	UC	X	X	
	<i>Pseudoboa newiedii</i>	RES	FC	X	X	
	<i>Spilotes pullatus pullatus</i>	RE	C		X	
	<i>Tantilla melanocephala</i>	RE	FC		X	
Elapidae	<i>Micrurus cercinalis</i>	RES	C		X	
Loptotyphlopidae	<i>Leptotyphlops albifrons</i>	RE	C	X	X	

Note: \* The category Scrub and Agriculture includes wet grasslands and earth-lined canals

Taxonomy based on Murphy (2008)

Habitat and distribution based on Murphy (1997) R- Rainforest E- Forest Edge S- Savannah Aq – Aquatic

Abundance based on Boos 1984 C- Common, FC- Fairly Common, UC - Uncommon R – Rare

**Table 5-16 Birds of Trinidad Likely to be Found Within San Fernando and Environs and the Habitats in Which They are Likely to be Found**

Species	Status & Abundance		Residential	Coastal	Scrub and agriculture	Other
Pelicanidae						
Brown Pelican, <i>Pelicanus occidentalis</i>	BR	A		X		
Phalacrocoracidae						
Neotropic Cormorant, <i>Phalacrocorax brasilianus</i>	MS	C		X		
Anhingidae						
Anhinga, <i>Anhinga anhinga</i>	MS	U		X		
Fregatidae						
Magnificent Frigatebird, <i>Fregata magnificens</i>	BR	C		X		
Ardeidae						
Boat-billed Heron, <i>Cochlearius cochlearius</i>	BR	R		X		
Black-crowned Night-heron, <i>Nycticorax nycticorax</i>	BR	C		X	X	
Yellow-crowned Night-heron, <i>Nyctanassa violacea</i>	BR	C		X		
Striated Heron, <i>Butorides striatus</i>	BR	C		X	X	
Cattle Egret, <i>Bubulcus ibis</i>	BR	A		X	X	





**Table 5-16 Birds of Trinidad Likely to be Found Within San Fernando and Environs and the Habitats in Which They are Likely to be Found (continued)**

Species	Status & Abundance		Residential	Coastal	Scrub and agriculture	Other
Great Blue Heron, <i>Ardea herodias</i>	MN	U		X		
Cocoi Heron, <i>Ardea cocoi</i>	MS	Sc		X		
Great Egret, <i>Ardea alba</i>	BV	C		X		
Tricolored Heron, <i>Egretta tricolor</i>	BV	C		X		
Snowy Egret, <i>Egretta thula</i>	BV	A		X	X	
Little Blue Heron, <i>Egretta caerulea</i>	BV	A		X		
Threskiornithidae						
Scarlet Ibis, <i>Eudocimus ruber</i>	BV	L		X		
Cathartidae						
Turkey Vulture, <i>Cathartes aura</i>	BR	A			X	
Black Vulture, <i>Coragyps atratus</i>	BR	A		X	X	
Phoenicopteridae						
Greater Flamingo, <i>Phoenicopterus ruber</i>	MS	R		X		
Accipitridae						
Osprey, <i>Pandion haliaetus</i>	MN	C		X		
Pearl Kite, <i>Gampsonyx swainsonii</i>	BR	U			X	
Long-winged Harrier, <i>Circus buffoni</i>	BR	U			X	
Grey Hawk, <i>Asturina nitida</i>	BR	C	X		X	
Common Black-hawk, <i>Buteogallus anthracinus</i>	BR	C		X	X	
Rufous Crab-hawk, <i>Buteogallus aequinoctialis</i>	BR	R		X		
Savannah Hawk, <i>Buteogallus meridionalis</i>	BR	C			X	
Short-tailed Hawk, <i>Buteo brachyurus</i>	BR	C			X	
Zone-tailed Hawk, <i>Buteo albonotatus</i>	BR	C			X	
Falconidae			X			
Yellow-headed Caracara, <i>Milvago chimachima</i>	BR	C	X	X	X	
Merlin, <i>Falco columbarius</i>	MN	U	X	X	X	
Aplomado Falcon, <i>Falco femoralis</i>	MS	R		X		
Bat Falcon, <i>Falco rufifigularis</i>	BR	Sc			X	
Peregrine Falcon, <i>Falco peregrinus</i>	MN	U	X	X	X	
Aramidae						
Limpkin, <i>Aramus guarauna</i>	BR	U			X	
Rallidae						



**Table 5-16 Birds of Trinidad Likely to be Found Within San Fernando and Environs and the Habitats in Which They are Likely to be Found (continued)**

Species	Status & Abundance		Residential	Coastal	Scrub and agriculture	Other
Clapper Rail, <i>Rallus longirostris</i>	BR	L		X		
Grey-necked Wood-rail, <i>Aramides cajanea</i>	BR	-			X	
Common Moorhen, <i>Gallinula chloropus</i>	BR	C				Marsh
Purple Gallinule, <i>Porphyrio martinica</i>	BR	C				Marsh
Charadriidae						
Southern Lapwing, <i>Vanellus chilensis</i>	BR	A		X	X	
American Golden-Plover, <i>Pluvialis dominica</i>	MN	U				Lawns
Black-bellied Plover, <i>Pluvialis squatarola</i>	MN	C		X		
Semipalmated Plover, <i>Charadrius semipalmatus</i>	MN	C		X		
Wilson's Plover, <i>Charadrius wilsonia</i>	MS	U		X		
Collared Plover, <i>Charadrius collaris</i>	BD	C		X		
Recurvirostridae						
Black-necked Stilt, <i>Himantopus mexicanus</i>	BD	C		X		
Scolopacidae						
Short-billed Dowitcher, <i>Limnodromus griseus</i>	MN	C		X		
Hudsonian Godwit, <i>Limosa haemastica</i>	MN	Sc		X		
Marbled Godwit, <i>Limosa fedoa</i>	MN	R		X		
Whimbrel, <i>Numenius phaeopus</i>	MN	C		X		
Greater Yellowlegs, <i>Tringa melanoleuca</i>	MN	C		X		
Lesser Yellowlegs, <i>Tringa flavipes</i>	MN	A		X		
Solitary Sandpiper, <i>Tringa solitaria</i>	MN	C		X		
Willet, <i>Catoptrophorus semipalmatus</i>	MN	C		X		
Spotted Sandpiper, <i>Actitis macularia</i>	MN	C		X		
Ruddy Turnstone, <i>Arenaria interpres</i>	MN	C		X		
Red Knot, <i>Calidris canutus</i>	MN	U		X		
Sanderling, <i>Calidris alba</i>	MN	U		X		



**Table 5-16 Birds of Trinidad Likely to be Found Within San Fernando and Environs and the Habitats in Which They are Likely to be Found (continued)**

Species	Status & Abundance		Residential	Coastal	Scrub and agriculture	Other
Semipalmated Sandpiper, <i>Calidris pusilla</i>	MN	A		X		
Western Sandpiper, <i>Calidris mauri</i>	MN	A		X		
Least Sandpiper, <i>Calidris minutilla</i>	MN	A		X		
White-rumped Sandpiper, <i>Calidris fuscicollis</i>	MN	U		X		
Pectoral Sandpiper, <i>Calidris melanotos</i>	MN	U				Lawns
Stilt Sandpiper, <i>Calidris himantopus</i>	MN	C		X		
Jacanidae						
Wattled Jacana, <i>Jacana jacana</i>	BR	A				Marsh
Stercorariidae						
Parasitic Jaeger, <i>Stercorarius parasiticus</i>	O	Sc		X		
Laridae						
Ring-billed Gull, <i>Larus delawarensis</i>	MN	R		X		
Lesser Black-backed Gull, <i>Larus fuscus</i>	MN	U		X		
Kelp Gull, <i>Larus dominicanus</i>	MN	VR				
Herring Gull, <i>Larus argentatus</i>	V	VR				
Laughing Gull, <i>Larus atricilla</i>	BV	A		X		
Franklin's Gull, <i>Larus pipixcan</i>	MN	VR				
Sabine's Gull, <i>Xema sabini</i>	W	VR				
Gull-billed Tern, <i>Sterna nilotica</i>	MN	U		X		
Sandwich Tern, <i>Sterna sandvicensis</i>	MN/S	U		X		
Royal Tern, <i>Sterna maxima</i>	MN(B)	C		X		
Common Tern, <i>Sterna hirundo</i>	MN	C		X		
Yellow-billed Tern, <i>Sterna superciliaris</i>	MS	C		X		
Black Tern, <i>Chlidonias niger</i>	MN	Sc		X		
Large-billed Tern, <i>Phaetusa simplex</i>	MS	C		X		
Black Skimmer, <i>Rynchops niger</i>	MS	C		X		
Columbidae						
Common Ground-dove, <i>Columbina passerina</i>	BR	C			X	
Plain-breasted Ground-dove, <i>Columbina minuta</i>	BR	U			X	



**Table 5-16 Birds of Trinidad Likely to be Found Within San Fernando and Environs and the Habitats in Which They are Likely to be Found (continued)**

Species	Status & Abundance		Residential	Coastal	Scrub and agriculture	Other
Ruddy Ground-dove, <i>Columbina talpacoti</i>	BR	A	X		X	
Rock Dove, <i>Columba livia</i>	Feral	A	X		X	
Eared Dove, <i>Zenaida auriculata</i>	BD	C		X	X	
White-tipped Dove, <i>Leptotila verreauxi</i>	BR	C	X		X	
Psittacidae						
Green-rumped Parrotlet, <i>Forpus passerinus</i>	BR	U	X	X	X	
Yellow-crowned Parrot, <i>Amazona ochrocephala</i>	BR	C	X		X	
Orange-winged Parrot, <i>Amazona amazonica</i>	BR	A		X	X	
Cuculidae						
Mangrove Cuckoo, <i>Coccyzus minor</i>	BR	Sc		X		
Greater Ani, <i>Crotophaga major</i>	BR	U		X	X	
Smooth-billed Ani, <i>Crotophaga ani</i>	BR	A	X	X	X	
Striped Cuckoo, <i>Tapera naevia</i>	BR	C		X	X	
Tytonidae						
Barn Owl, <i>Tyto alba</i>	BR	U	X	X	X	
Strigidae						
Tropical Screech-owl, <i>Megascops choliba</i>	BR	U	X		X	
Ferruginous Pygmy-owl, <i>Glaucidium brasilianum</i>	BR	C	X		X	
Nyctibiidae						
Common Potoo, <i>Nyctibius griseus</i>	BR	U		X		
Caprimulgidae						
Lesser Nighthawk, <i>Chordeiles acutipennis</i>	MN	C		X	X	
Nacunda Nighthawk, <i>Podager nacunda</i>	MS	Sc			X	
Common Pauraque, <i>Nyctidromus albicollis</i>	BR	C			X	
White-tailed Nightjar, <i>Caprimulgus cayennensis</i>	BR	C			X	
Apodidae						



**Table 5-16 Birds of Trinidad Likely to be Found Within San Fernando and Environs and the Habitats in Which They are Likely to be Found (continued)**

Species	Status & Abundance		Residential	Coastal	Scrub and agriculture	Other
Short-tailed Swift, <i>Chaetura brachyura</i>	BR	A	X		X	
Fork-tailed Palm-swift, <i>Tachornis squamata</i>	BR	C			X	
Trochilidae						
Rufous-breasted Hermit, <i>Glaucis hirsutus</i>	BR	C				Forest
Little Hermit, <i>Phaethornis longuemareus</i>	BR	C				Forest
Green-throated Mango, <i>Anthracothorax viridigula</i>	BR	L		X		
Ruby-topaz Hummingbird, <i>Chrysolampis mosquitus</i>	BD	C	X	X	X	
Tufted Coquette, <i>Lophornis ornate</i>	BR	U			X	
White-chested Emerald, <i>Amazilia brevirostris</i>	BR	C		X	X	
Copper-rumped Hummingbird, <i>Amazilia tobaci</i>	BR	A	X	X	X	
Long-billed Starthroat, <i>Heliomaster longirostris</i>	BR	Sc		X		
Alcedinidae						
Ringed Kingfisher, <i>Ceryle torquata</i>	BR	U		X		
Green Kingfisher, <i>Chloroceryle Americana</i>	BR	C		X		
Pygmy Kingfisher, <i>Chloroceryle aenea</i>	BR	U		X		
Picidae						
Lineated Woodpecker, <i>Dryocopus lineatus</i>	BR	C	X		X	
Furnariidae						
Pale-breasted Spinetail, <i>Synallaxis albescens</i>	BR	U			X	
Yellow-chinned Spinetail, <i>Certhiaxis cinnamomea</i>	BR	C			X	
Dendrocolaptidae						
Straight-billed Woodcreeper, <i>Xiphorhynchus picus</i>	BR	L		X		
Thamnophilidae						



**Table 5-16 Birds of Trinidad Likely to be Found Within San Fernando and Environs and the Habitats in Which They are Likely to be Found (continued)**

Species	Status & Abundance		Residential	Coastal	Scrub and agriculture	Other
Black-crested Antshrike, <i>Sakesphorus Canadensis</i>	BR	C		X		
Barred Antshrike, <i>Thamnophilus doliatus</i>	BR	C	X		X	
Tyrannidae						
Yellow-bellied Elaenia, <i>Elaenia flavogaster</i>	BR	C	X	X	X	
Southern Beardless Tyrannulet, <i>Camptostoma obsoletum</i>	BR	C			X	
Northern scrub Flycatcher, <i>Sublegatus arenarum</i>	BR	U		X		
Yellow-breasted Flycatcher, <i>Tolmomyias flavivrentris</i>	BR	C		X		
Bran-colored Flycatcher, <i>Myiophobus fasciatus</i>	BR	U		X	X	
Pied Water-tyrant, <i>Fluvicola pica</i>	BR	C		X	X	
White-headed Marsh-tyrant, <i>Arundinicola leucocephala</i>	BR	C		X	X	
Piratic Flycatcher, <i>Legatus leucophaius</i>	BD	C			X	
Great Kiskadee, <i>Pitangus sulphuratus</i>	BR	A	X	X	X	
Streaked Flycatcher, <i>Myiodynastes maculates</i>	BR	C			X	
Boat-billed Flycatcher, <i>Megarynchus pitangua</i>	BR	C		X	X	
Tropical Kingbird, <i>Tyrannus melancholicus</i>	BR	A	X	X	X	
Fork-tailed Flycatcher, <i>Tyrannus savanna</i>	MS	A		X	X	
Grey Kingbird, <i>Tyrannus dominicensis</i>	BV	U		X	X	
Brown-crested Flycatcher, <i>Myiarchus tyrannulus</i>	BR	U		X		
White-winged Becard, <i>Pachyramphus polychopterus</i>	BR	U		X		
Vireonidae						
Rufous-browed Peppershrike, <i>Cyclarhis gujanensis</i>	BR	C	X	X	X	



**Table 5-16 Birds of Trinidad Likely to be Found Within San Fernando and Environs and the Habitats in Which They are Likely to be Found (continued)**

Species	Status & Abundance		Residential	Coastal	Scrub and agriculture	Other
Red-eyed Vireo, <i>Vireo olivaceus</i>	BV	C		X	X	
Golden-fronted Greenlet, <i>Hylophilus aurantiifrons</i>	BR	C		X	X	
Hirundinidae						
White-winged Swallow, <i>Tachycineta albiventer</i>	BR	C	X	X	X	
Grey-breasted Martin, <i>Progne chalybea</i>	BR	A	X	X	X	
Blue and White Swallow, <i>Pygochelidon cyanoleuca</i>	MS	U		X	X	
Southern Rough-winged Swallow, <i>Stelgidopteryx ruficollis</i>	BR	C			X	
Barn Swallow, <i>Hirundo rustica</i>	MN	C		X	X	
Bank Swallow, <i>Riparia riparia</i>	MN	Sc			X	
Troglodytidae						
House Wren, <i>Troglodytes aedon</i>	BR	C	X	X	X	
Rufous-breasted Wren, <i>Thryothorus rutilus</i>	BR	C			X	
Sylviidae						
Long-billed Gnat-wren, <i>Ramphocaenus melanurus</i>	BR	C		X	X	
Turdidae						
Bare-eyed Robin, <i>Turdus nudigenis</i>	BR	C	X	X	X	
Cocoa Thrush, <i>Turdus fumigatus</i>	BR	C				Forest
Mimidae						
Tropical Mockingbird, <i>Mimus gilvus</i>	BR	C	X	X	X	
Coerebidae						
A Bananaquit, <i>Coereba flaveola</i>	BR	A	X	X	X	
Thraupidae						
White-shouldered Tanager, <i>Tachyphonus luctuosus</i>	BR	U			X	
White-lined Tanager, <i>Tachyphonus rufus</i>	BR	C	X		X	
Silver-beaked Tanager, <i>Ramphocelus carbo</i>	BR	C	X		X	
Blue-grey Tanager, <i>Thraupis episcopus</i>	BR	C	X	X	X	
Palm Tanager, <i>Thraupis palmarum</i>	BR	A	X	X	X	



**Table 5-16 Birds of Trinidad Likely to be Found Within San Fernando and Environs and the Habitats in Which They are Likely to be Found (continued)**

Species	Status & Abundance		Residential	Coastal	Scrub and agriculture	Other
Turquoise Tanager, <i>Tangara mexicana</i>	BR	C			X	
Bicolored Conebill, <i>Conirostrum bicolor</i>	BR	C		X		
Emberizidae						
Saffron Finch, <i>Sicalis flaveola</i>	BR	U	X		X	
Blue-black Grassquit, <i>Volatinia jacarina</i>	BR	A	X		X	
Red-capped Cardinal, <i>Paroaria gularis</i>	BR	U		X	X	
Cardinalidae			X			
Greyish Saltator, <i>Saltator coerulescens</i>	BR	C	X	X	X	
Dickcissel, <i>Spiza americana</i>	MN	C			X	
Parulidae						
Yellow Warbler, <i>Dendroica petechia</i>	MN	C	X	X	X	
American Redstart, <i>Setophaga ruticilla</i>	MN	C		X	X	
Prothonotary Warbler, <i>Protonotaria citrea</i>	MN	Sc		X		
Northern Waterthrush, <i>Seiurus noveboracensis</i>	MN	C		X	X	
Masked Yellowthroat, <i>Geothlypis aequinoctialis</i>	BR	U			X	
Icteridae						
Crested Oropendola, <i>Psarocolius decumanus</i>	BR	A			X	
Yellow Oriole, <i>Icterus nigrogularis</i>	BR	C	X	X	X	
Giant Cowbird, <i>Molothrus oryzivora</i>	BR	U			X	
Shiny Cowbird, <i>Molothrus bonariensis</i>	BR	A	X	X	X	
Carib Grackle, <i>Quiscalus lugubris</i>	BR	A	X	X	X	
Red-breasted Blackbird, <i>Sturnella militaris</i>	BR	C			X	
Yellow-hooded Blackbird, <i>Chrysomus icterocephalus</i>	BR	A		X	X	Marsh
Euphonidae						





**Table 5-16 Birds of Trinidad Likely to be Found Within San Fernando and Environs and the Habitats in Which They are Likely to be Found (continued)**

Species	Status & Abundance		Residential	Coastal	Scrub and agriculture	Other
	BR	U				
Trinidad Euphonia, <i>Euphonia trinitatis</i>	BR	U		X	X	
Violaceous Euphonia, <i>Euphonia violacea</i>	BR	C			X	
Estrildidae						
Common Waxbill, <i>Estrilda astrild</i>	BR	L			X	

Note: The Coastal habitat includes Mangrove, Mudflats and seabird roosts

Nomenclature (Remsen et al 2007). Status and abundance categories (White et al 2007)

BR Resident species without significant movement out of Trinidad and Tobago. Breeding is assumed even if no nest has been documented.

BD Species that breed locally and migrate or disperse to the mainland (sometimes only partially) in the non-breeding period.

BV Resident, regularly breeding species whose numbers are augmented by visitors from continental N & S America

MN Non-breeding migrants from continental North America. Predominantly over-wintering.

MS Migrants from South America. These species may be avoiding the Austral winter, dispersing from breeding grounds but generally show regular seasonal movements. May occasionally breed.

O Oceanic, may be observed from shore.

W Generally sedentary or wandering species at the edge of their range. Reported less than once per decade.

A Abundant; widespread and usually in some numbers in suitable habitat.

C Common, usually found in suitable habitat.

U Uncommon; occasionally seen in suitable habitat in small numbers or singly.

Sc Scarce, very few (less than 5) records in a year.

R Rare- not recorded annually.

VR Very Rare Less than one record per decade.

L Locally distributed in restricted habitat; but may be not uncommon there



**Table 5-17 Mammals of Trinidad Which May be Expected Within San Fernando and Environs**

Order	Family	Sp Alkins	Common Name
Marsupialia	Didelphidae	<i>Didelphis marsupialis insularis</i>	Black-eared Opossum
Edentata	Myrmecophagidae	<i>Cyclopes didactylus didactylus</i>	Two-toed Anteater
Chiroptera	Emballonuridae	<i>Rhynchiscus naso</i>	Jacob's Ladder Bat
	Emballonuridae	<i>Saccopteryx bilineata perspicillifer</i>	Greater Trinidadian two-lined Bat
	Emballonuridae	<i>Saccopteryx leptura</i>	Lesser two-lined Bat
	Noctilionidae	<i>Noctilio leporinus leporinus</i>	Fish-eating Bat
	Mormoopidae	<i>Chilonycteris rubiginosa fusca</i>	Greater Mustache Bat
	Mormoopidae	<i>Pteronotus davyi davyi</i>	Naked-backed Bat
	Mormoopidae	<i>Mormoops megalophylla tumidiceps</i>	Trinidadian Leaf-chinned Bat
	Phyllostomidae	<i>Micronycteris sp.</i>	Bat
	Phyllostomidae	<i>Phyllostomus hastatus hastatus</i>	Greater Spear-nosed Bat
	Phyllostomidae	<i>Glossophaga soricina soricina</i>	Bat
	Phyllostomidae	<i>Anoura geoffroyi geoffroyi</i>	Tailless Long-tongued Bat
	Phyllostomidae	<i>Carollia perspicillata perspicillata</i>	Short-tailed Fruit Bat
	Phyllostomidae	<i>Sturnira lilium lilium</i>	South American Yellow-shouldered Bat
	Phyllostomidae	<i>Uroderma bilobatum bilobatum</i>	Yellow-eared or Tent Making Bat
	Phyllostomidae	<i>Artibeus jamaicensis trinitatis</i>	Lesser Trinidadian Fruit Bat
	Phyllostomidae	<i>Artibeus lituratus palmarum</i>	Greater Trinidadian Fruit Bat
	Vespertilionidae	<i>Myotis nigricans nigricans</i>	Little Black Bat
	Molossidae	<i>Molossus ater ater</i>	Large Free-tailed Bat
	Molossidae	<i>Molossus major major</i>	Small Free-tailed Bat
Rodentia	Sciuridae	<i>Sciurus granatensis chapmani</i>	Trinidadian Squirrel
	Muridae	<i>Oryzomys concolor speciosus</i>	Arboreal Rice Rat
	Muridae	<i>Zygodontomys brevicauda brevicauda</i>	Trinidadian Cane Rat
	Muridae	<i>Rattus rattus rattus</i>	Black Rat
	Muridae	<i>Rattus norvegicus</i>	Wharf Rat
	Muridae	<i>Mus musculus brevirostris</i>	House mouse
	Dasyproctidae	<i>Dasyprocta agouti</i>	Agouti
Carnivora	Viverridae	<i>Herpestes auropunctatus</i>	Small Indian Mongoose

Note: \* Taxonomy follows Alkins (1979). Likely list of bats conservative with assistance from Geoffrey Gomes.



**Table 5-18 Historical Records of Aquatic Species Found Within San Fernando and Environs**

Family	Species	Common Name	epas 2005	IMA 2003	Kenny 1995
<i>Fishes</i>					
Achiridae	<i>Trinectes sp</i>	Flat Fish	X		
Anablepidae	<i>Anableps anableps</i>	Four-eyed Fish	X		
Ariidae	<i>Ariopsis bonillai</i> ( <i>Hexanemataichthys spp.</i> )	Catfish	X	X	
	<i>Arius sp.</i>	Catfish	X		
	<i>Cathorops spixii</i>	Catfish	X		
	<i>Rhamdia. quelen</i>	Barbe	X		X
	<i>Pseudochanna nodosa</i>	Cocosoda Catfish		X	
Batrachoididae	<i>Batrachoides surinamensis</i>	Crapaud Fish	X	X	
Callichthyidae	<i>Callichthys callichthys</i>	Chato			X
	<i>Corydoras aeneus</i>	Pui-Pui			X
	<i>Hoplosternum littorale</i>	Cascadu		X	X
Carangidae	<i>Caranx hippos</i>	Cavalli		X	
	<i>Chloroscombrus chrysurus</i>	Plateau	X		
	<i>Oligoplites palometa</i>	Zapate	X		
Centropomidae	<i>Centropomus undecimalis</i>	Brochet	X	X	
Cichlidae	<i>Aequidens pulcher</i>	Green Coscorob		X	X
	<i>Cichlasoma taenia</i>	Coscorob			X
	<i>Crenicichia alta</i>	Millet			X
	<i>Oreochromis mossambicus</i>	Tilapia			X
Characidae	<i>Astyanax bimaculats</i>	Sardine Doree		X	X
	<i>Corynopoma riisei</i>	Swordtail Sardine			X
	<i>Hemibrycon</i>			X	
	<i>Hemigrammus unilineatus</i>	Feather Sardine			X
	<i>Megalampodus axelrodi</i>	Riddlei			X
	<i>Roeboides dayi</i>	Glass Sardine		X	
Clupeidae	<i>Harengula jaguna</i>	Hardback Herring	X		
	<i>Odontognathus compressus</i>	Sardine	X		
Cyprinodontidae	<i>Rivulus hartii</i>	Jumping guabine			X
Epinephelinae	<i>Epinephelus itajara</i>	Jewfish		X	
Eleotridae	<i>Dormitator maculatus</i>				X
	<i>Eleptris pisonis</i>	Guabine			X
Ephippidae	<i>Chaetodipterus faber</i>	Paoua	X		
Engraulidae	<i>Anchovia sp.</i>	Jashua	X		
	<i>A. trinitatis</i>	Sardine	X		
	<i>Cetengraulis edentulus</i>	Sardine	X		
Erythrinidae	<i>Hoplias malabaricus</i>	Guabine		X	X
Gerreidae	<i>Diapterus rhombeus</i>	Blinch	X	X	



**Table 5-18 Historical Records of Aquatic Species Found Within San Fernando and Environs (continued)**

Family	Species	Common Name	epas 2005	IMA 2003	Kenny 1995
Gymnotidae	<i>Gymnotus carapo</i>	Cutlass knife			X
Haemulidae	<i>Genyatremus luteus</i>	Trawat		X	
Loricariidae	<i>Hypostomus robinii</i>	Teta		X	X
Lutjanidae	<i>Lutjanus cyanopterus</i>	Grey Snapper		X	
Megalopidae	<i>Megalops atlanticus</i>	Tarpon		X	
Mugilidae	<i>Mugil curema</i>	Mullet	X	X	
	<i>Mugil cephalus</i>			X	
Nandidae	<i>Polycentrus schomburgkii</i>	King Coscarob		X	X
Poeciliidae	<i>Poecilia reticulata</i>	Guppy 7 Colours		X	X
	<i>Poecilia picta</i>	Millions			X
	<i>Poecilia vivipara</i>	Millions			X
Pomadasyidae	<i>Haemulon bonariense</i>	Grunt		X	
Rivulidae	<i>Rivulus hartii</i>	Jumping Guabine			X
Sciaenidae	<i>Cynoscion acoupa</i>	Acoupa Weakfish		X	
	<i>Larimus breviceps</i>	Weiwei	X		
	<i>Macrodon ancyclodon</i>	King Weakfish		X	
	<i>Micropogon furnieri</i>	Racando (Cro cro)	X		
	<i>Ophioscion punctatissimus</i>	Spotted Croaker		X	
	<i>Stellifer</i>			X	
Soleidae	<i>Achirus sp.</i>	Flounder		X	
symbranchidae	<i>Symbranchus marmoratus</i>	Zange			X
<i>Shrimp</i>					
Penaeidae	<i>Penaeus notialis</i>	Red Shrimp	X		
	<i>Penaeus schmitti</i>	White Shrimp (Cork)	X		
	<i>Xiphopenaeus kroyeri</i>	Seabob	X		
<i>Crabs</i>					
Ocypodidae	<i>Uca sp.</i>	Fiddler Crab	X		
Portunidae	<i>Callinectes danae</i>	Blue (Marine) Crab	X		
	<i>Callinectes sapidus</i>	Blue (Marine) Crab	X		



**Table 5-19 Butterfly Species Common or Abundant and Widespread in Trinidad and are Likely to Occur in the Greater San Fernando Area.**

Family	Species
Satyridae	Night, <i>Taygetis virgilia</i>
	Night, <i>Taygetis echo</i>
	Night, <i>Taygetis cleopatra</i>
	Night, <i>Taygetis andromeda</i>
	Night, <i>Taygetis penelea</i>
	Ringlet, <i>Euptychia hesione</i>
	Ringlet, <i>Euptychia terrestris</i>
	Ringlet, <i>Euptychia palladia</i>
	Ringlet, <i>Euptychia penelope</i>
	Ringlet, <i>Euptychia hermes</i>
	Ringlet, <i>Euptychia libye</i>
	Ringlet, <i>Euptychia arnaea</i>
Danaiidae	Monarch, <i>Danaus plexippus megalippe</i>
	Small Lace-Wing, <i>Actinote pellenia trinitatis</i>
Ithomiidae	Tiger, <i>Tithorea harmonia megara</i>
	Sweet oil, <i>Mechanitis isthmia kayei</i>
	Sweet oil, <i>Mechanitis polymnia solaris</i>
	Brown Transparent, <i>Hypoleria ocalea</i>
	Blue Transparent, <i>Ithomia pellucida pellucida</i>
Heliconiade	Blue Grecian, <i>Heliconius wallacei</i>
	Small Blue Grecian, <i>Heliconius sara</i>
	Postman, <i>Heliconius melpomene</i>
	Small Postman, <i>Heliconius erato</i>
	Isabella tiger, <i>Heliconius isabella</i>
	Small Flambeau, <i>Heliconius aliphera</i>
	Flambeau, <i>Colaenis iulia</i>
	Scarce Silver-spotted Flambeau, <i>Dione junio</i>
	Silver spotted flambeau, <i>Agraulis vanillae</i>
Nymphalidae	Bamboo Page, <i>Metamorpha stelenes</i>
	Biscuit, <i>Anartia jatrophe</i>
	Coolie, <i>Anartia amathea</i>



**Table 5-19 Butterfly Species Common or Abundant and Widespread in Trinidad and are Likely to Occur in the Greater San Fernando Area.** (continued)

Family	Species
Nymphalidae	Little Soldier, <i>Chlosyne saundersii</i>
	Donkey's Eye, <i>Precis lavinia zonatis</i>
	Handkerchief, <i>Phycoides leucodesma</i>
	Blue-Tinted Handkerchief, <i>Dynamine theseus</i>
	Small Dynamine, <i>Dynamine artemesia</i>
	Grey Handkerchief, <i>Mestra hypermestra cana</i>
	Grey Cracker, <i>Hamadryas ferentina</i>
	Cracker, <i>Hamadryas feronia</i>
	89, <i>Callicore aurelia</i>
	Four-continent, <i>Adelpha iphicla</i>
	Five Continent, <i>Adelpha cytherea</i>
	Zebra, <i>Colobura dirce</i>
	Morphidae
Brassolidae	Cattle Heart, <i>Parides anchises cymocles</i>
Papilionidae	Spear-Winged Cattle Heart, <i>Parides neophilus parianus</i>
	King Page, <i>Papilio thoas nealces</i>
	Small King Page, <i>Papilio homothoas</i>
Peridae	Common Yellow, <i>Phoebis sennae</i>
	Apricot, <i>Phoebis argante</i>
	Gonatryx, <i>Anteos maerula</i>
	Small White, <i>Eurema albula</i>
	Little Yellowie, <i>Eurema venusta</i>
	Small yellow, <i>Eurema leuce</i>
	Small Banded Yellow, <i>Eurema elathea</i>
	Cabbage white, <i>Ascia monuste</i>
Riodinidae	Brown and Cream, <i>Nymula Nymula calyce</i>
Lycaenidae	Common Blue, <i>Hemiargus hanno</i>
	Meadow blue, <i>Leptotes cassius</i>
	Dusty Blue Hairstreak, <i>Calycopis beon</i>
	Large Brilliant, <i>Oenomaus ortygnus</i>
	Black-Backed Blue, <i>Mithras hemon</i>



### 5.11.1.3 Field Studies

Field studies were conducted in terrestrial and aquatic habitats within the project area, at locations mentioned in Section 5.11.1.1 in order to authenticate the historical background data of species. The result of these studies displayed that with the exception of birds; comparatively few vertebrate species were observed, when compared to historical possible species.

Evidence of amphibians was limited to one chorus of *Leptodactylus validus* and one foam nest of *Engystomops pustulosus*. Reptiles actually observed during the site visits were limited to one Spectacled Caiman, *Caiman crocodilus* a few *Ameiva ameiva* and one *Gonatodes vittatus*. Residents also advised of the presence of Iguanas, *Iguana iguana*. There was conflicting opinion on the presence of a Matte, *Tupinambis teguixin*.

The only mammals observed were the Trinidad Squirrel, *Sciurus granatensis*. Residents advised of the occurrence of Black-eared Opossum, *Didelphis marsupialis* and workers at San Fernando Hill thought that there may be a few surviving Agouti, *Dasyprocta agouti*.

Very few butterflies were seen during the field visits. This is likely, in part, due to the timing of the field visits. The latter half of the wet season is generally not the best time for collecting butterflies and years with a comparatively wet dry-season are not as good for butterfly collection as years with a harsh dry season (Barcant (1970)). Those butterflies which were observed are listed in Table 5-20.

**Table 5-20 Butterflies Observed Within San Fernando and Environs, October 2009**

Family	Species*
Satyridae	<i>Euptychia</i> sp., Ringlet
Danaidae	<i>Danaus plexippus</i> , Monarch
Ithomiidae	<i>Mechanitis polymnia</i> , Sweetoil
Heliconidae	<i>Heliconius</i> sp. Postman
Heliconidae	<i>Calaenis iulia</i> , Flambeau
Heliconidae	<i>Dione junio</i> , Scarce Silver-spotted Flambeau
Nymphalidae	<i>Metamorphia stelenes</i> , Bamboo Page
Nymphalidae	<i>Anartia jatrophe</i> , Biscuit
Nymphalidae	<i>Anartia amathea</i> , Coolie
Nymphalidae	<i>Precis lavinia zonatis</i> , Donkey's Eye
Brassolidae	<i>Caligo teucer insulanus</i> , Cocoa Mort Bleu
Papilionidae	<i>Papilio homothoas</i> , Small King Page

Note: \* Names follow Barcant (1970) except for *Mechanitis polymnia*.



Aquatic Field Studies

Within the catchment areas surveyed a total of sixty-six (66) finfish and shrimp specimens were collected during the sampling period. Five of the thirteen locations had no fish presence. These were the Ciperu Upper, Ciperu Middle 1, Ciperu Middle 2, Guaracara Upper and Guaracara Middle locations. These specimens belonged to ten (10) species representing ten (10) different families. A list of all the species caught within the rivers surveyed is provided in Table 5-21.

The predominant species observed in upstream riverine locations (MU and VM) was the Guppy (*Poecilia reticulata*). These fish are tolerant of polluted, turbid waters with low levels of dissolved oxygen. There were also two main species collected in the middle course of the Vistabella River; Black Tilapia (*Oreochromis mossambicus*) and Mullet (*Mugil* sp.). Both these species are generally found in brackish to freshwater environments with “sluggish” slow moving waters. Their presence suggests that the station along the middle course of the Vistabella River can be subjected to tidal influences.

Within the lower courses of the rivers surveyed, Catfish (*Arius* sp.) appeared to be the most predominant species. However, this species is benthopelagic and, as such, their prevalence in the sample population may have been as a result of the gear type (fish pots) used for fishing and not a true reflection of the aquatic community structure.

**Table 5-21 Description of Fish Species Captured per Sample Station**

Family	Species	Common Name	GL	ML	MU	VL	VM	CL	GoL	GoM
Achiridae	<i>Achirus lineatus</i>	Lined Sole/ Flounder								X
Anablepidae	<i>Anableps anableps</i>	Four-eyed Fish								X
Ariidae	<i>Arius</i> sp.	Catfish	X	X		X		X		X
Centropomidae	<i>Centropomus undecimalis</i>	Brochet								X
Cichlidae	<i>Oreochromis mossambicus</i>	Tilapia					X			
Gerreidae	<i>Diapterus rhombeus</i>	Blinch	X	X						
Mugilidae	<i>Mugil</i> sp.	Mullet					X			
Penaeidae	<i>Xiphopenaeus kroyeri</i>	Honey Shrimp							X	
Poeciliidae	<i>Poecilia reticulata</i>	Guppy			X		X			
Sciaenidae	<i>Micropogon furnieri</i>	Racando	X						X	

Note: No samples were collected at Stations CU, CM1, CM2, GU and GM. As a result these locations are not cited in the table above.





### Bird Field Studies

Birds constituted the majority of vertebrate species observed during the field visits. Overall 84 species were observed, Table 5-22. The species observed were generally consistent with expectations for the different habitats with greatest numbers from the coastal habitats. Three species observed in Palmiste Park were unexpected, Rufous-breasted Hermit, *Glaucis hirsutus*, Little Hermit, *Phaethornis longuemareus*, and Cocoa Thrush, *Turdus fumigatus*. These species are usually associated with a forest environment, and while they are normally observed on the edges of forest they are seldom seen far from a forest environment.

The small patch of mangrove at the mouth of the Guaracara River housed several bird species characteristic of mangrove. These species included Common Black Hawk, *Buteogallus anthracinus*, Straight-billed Woodcreeper, *Xiphorhynchus picus*, Brown-crested Flycatcher, *Myiarchus tyrannulus*, and Bicoloured Conebill, *Conirostrum bicolor*. This mangrove also supported populations of Blue Crabs *Cardisoma guanhumi*, Hairy Crabs *Ucides cordatus* and Fiddler Crabs *Uca* spp. No mangrove Tree Crabs, *Aratus pisonii* were observed.



**Table 5-22 Bird Species Observed Within San Fernando and Environs, October 2009**

Species	Scrub and agriculture	San Fernando Hill	Palmiste Park	Usine St. Madeline	Bellair Mudflats	Guaracara Mangrove	San Fernando Wharf	Boatyard	Cipero River
Pelicanidae									
Brown Pelican, <i>Pelicanus occidentalis</i>					36	10	261	20	
Fregatidae									
Magnificent Frigatebird, <i>Fregata magnificens</i>					X				
Ardeidae									
Black-crowned Night-heron, <i>Nycticorax nycticorax</i>					X				
Striated Heron, <i>Butorides striatus</i>				X					
Cattle Egret, <i>Bubulcus ibis</i>	X		X	X					
Tricolored Heron, <i>Egretta tricolor</i>								X	
Snowy Egret, <i>Egretta thula</i>				X	X		X	X	X
Little Blue Heron, <i>Egretta caerulea</i>					X				
Cathartidae									
Turkey Vulture, <i>Cathartes aura</i>	X								
Black Vulture, <i>Coragyps atratus</i>	X	X	X	X		X			
Accipitridae									
Osprey, <i>Pandion haliaetus</i>		X			X	20		X	
Common Black-hawk, <i>Buteogallus anthracinus</i>						X			
Zone-tailed Hawk, <i>Buteo albonotatus</i>	X								
Rallidae									
Common Moorhen, <i>Gallinula chloropus</i>				X					
Purple Gallinule, <i>Porphyrio martinica</i>			X	X					



**Table 5-22 Bird Species Observed Within San Fernando and Environs, October 2009 (continued)**

Species	Scrub and agriculture	San Fernando Hill	Palmiste Park	Usine St. Madeline	Bellair Mudflats	Guaracara Mangrove	San Fernando Wharf	Boatyard	Cipero River
Charadriidae									
Southern Lapwing, <i>Vanellus chilensis</i>				X					
Black-bellied Plover, <i>Pluvialis squatarola</i>					X			X	
Semipalmated Plover, <i>Charadrius semipalmatus</i>					X	X		X	
Scolopacidae									
Whimbrel, <i>Numenius phaeopus</i>					X			X	
Lesser Yellowlegs, <i>Tringa flavipes</i>	X				X				X
Willet, <i>Catoptrophorus semipalmatus</i>					X				
Spotted Sandpiper, <i>Actitis macularia</i>	X					X		X	X
Ruddy Turnstone, <i>Arenaria interpres</i>					X			X	
Semipalmated Sandpiper, <i>Calidris pusilla</i>	X			X	100+	X		X	X
Western Sandpiper, <i>Calidris mauri</i>					200+	X		X	
Least Sandpiper, <i>Calidris minutilla</i>						X			
White-rumped Sandpiper, <i>Calidris fuscicollis</i>						X			
Pectoral Sandpiper, <i>Calidris melanotos</i>									X
Jacaniidae									
Wattled Jacana, <i>Jacana jacana</i>				X					
Laridae									
Laughing Gull, <i>Larus atricilla</i>					200	X	16	X	
Gull-billed Tern, <i>Sterna nilotica</i>							X		
Common Tern, <i>Sterna hirundo</i>					39	X	X		



**Table 5-22 Bird Species Observed Within San Fernando and Environs, October 2009 (continued)**

Species	Scrub and agriculture	San Fernando Hill	Palmiste Park	Usine St. Madeline	Bellair Mudflats	Guaracara Mangrove	San Fernando Wharf	Boatyard	Cipero River
Large-billed Tern, <i>Phaetusa simplex</i>					55		X	X	
Columbidae									
Ruddy Ground-dove, <i>Columbina talpacoti</i>	X	X	X	X		X		X	
Rock Dove, <i>Columba livia</i>	X	X							
Eared Dove, <i>Zenaida auriculata</i>	X	X		X					
Psittacidae									
Green-rumped Parrotlet, <i>Forpus passerinus</i>	X	X	X			X			
Cuculidae									
Smooth-billed Ani, <i>Crotophaga ani</i>	X								
Striped Cuckoo, <i>Tapera naevia</i>	X								
Strigidae									
Ferruginous Pygmy-owl, <i>Glaucidium brasilianum</i>			X			X			
Apodidae									
Short-tailed Swift, <i>Chaetura brachyuran</i>		X							
Trochilidae									
Rufous-breasted Hermit, <i>Glaucis hirsutus</i>			X						
Little Hermit, <i>Phaethornis longuemareus</i>			X						
Copper-rumped Hummingbird, <i>Amazilia tobaci</i>		X	X			X			
Alcedinidae									



**Table 5-22 Bird Species Observed Within San Fernando and Environs, October 2009 (continued)**

Species	Scrub and agriculture	San Fernando Hill	Palmiste Park	Usine St. Madeline	Bellair Mudflats	Guaracara Mangrove	San Fernando Wharf	Boatyard	Cipero River
Pygmy Kingfisher, <i>Chloroceryle aenea</i>						X			
Furnariidae									
Pale-breasted Spinetail, <i>Synallaxis albescens</i>						X			
Yellow-chinned Spinetail, <i>Certhiaxis cinnamomea</i>				X					
Dendrocolaptidae									
Straight-billed Woodcreeper, <i>Xiphorhynchus picus</i>						X			
Thamnophilidae									
Barred Antshrike, <i>Thamnophilus doliatus</i>			X			X			
Tyrannidae									
Yellow-bellied Elaenia, <i>Elaenia flavogaster</i>	X	X		X					
Southern Beardless Tyrannulet, <i>Camptostoma obsoletum</i>	X		X						
Pied Water-tyrant, <i>Fluvicola pica</i>				X					X
White-headed Marsh-tyrant, <i>Arundinicola leucocephala</i>				X					
Great Kiskadee, <i>Pitangus sulphuratus</i>	X	X	X	X		X			
Boat-billed Flycatcher, <i>Megarynchus pitangua</i>		X							
Tropical Kingbird, <i>Tyrannus melancholicus</i>	X	X		X		X			



**Table 5-22 Bird Species Observed Within San Fernando and Environs, October 2009 (continued)**

Species	Scrub and agriculture	San Fernando Hill	Palmiste Park	Usine St. Madeline	Bellair Mudflats	Guaracara Mangrove	San Fernando Wharf	Boatyard	Cipero River
Fork-tailed Flycatcher, <i>Tyrannus savanna</i>	X								
Brown-crested Flycatcher, <i>Myiarchus tyrannulus</i>						X			
Vireonidae									
Rufous-browed Peppershrike, <i>Cyclarhis gujanensis</i>			X						
Red-eyed Vireo, <i>Vireo olivaceus</i>		X							
Hirundinidae									
White-winged Swallow, <i>Tachycineta albiventer</i>					X	X	X		
Grey-breasted Martin, <i>Progne chalybea</i>		X	X						
Southern Rough-winged Swallow, <i>Stelgidopteryx ruficollis</i>			X			X			
Barn Swallow, <i>Hirundo rustica</i>	X								
Troglodytidae									
House Wren, <i>Troglodytes aedon</i>	X	X	X					X	
Sylviidae									
Long-billed Gnat-wren, <i>Ramphocaenus melanurus</i>		X	X						
Turdidae									
Bare-eyed Robin, <i>Turdus nudigenis</i>	X	X	X	X		X			
Cocoa Thrush, <i>Turdus fumigatus</i>			X						



**Table 5-22 Bird Species Observed Within San Fernando and Environs, October 2009 (continued)**

Species	Scrub and agriculture	San Fernando Hill	Palmiste Park	Usine St. Madeline	Bellair Mudflats	Guaracara Mangrove	San Fernando Wharf	Boatyard	Cipero River
Mimidae									
Tropical Mockingbird, <i>Mimus gilvus</i>		X	X	X		X			
Coerebidae									
A Bananaquit, <i>Coereba flaveola</i>		X	X			X			
Thraupidae									
White-lined Tanager, <i>Tachyphonus rufus</i>		X	X			X			
Blue-grey Tanager, <i>Thraupis episcopus</i>	X	X	X	X		X			X
Bicolored Conebill, <i>Conirostrum bicolor</i>						X			
Emberizidae									
Saffron Finch, <i>Sicalis flaveola</i>		X				X		X	
Blue-black Grassquit, <i>Volatinia jacarina</i>		X		X		X			
Cardinalidae									
Greyish Saltator, <i>Saltator coerulescens</i>	X	X		X					
Parulidae									
Yellow Warbler, <i>Dendroica petechia</i>	X	X	X	X		X			
Northern Waterthrush, <i>Seiurus noveboracensis</i>						X			
Icteridae									
Crested Oropendola, <i>Psarocolius decumanus</i>	X		X						
Yellow Oriole, <i>Icterus nigrogularis</i>	X	X	X			X			



**Table 5-22 Bird Species Observed Within San Fernando and Environs, October 2009 (continued)**

Species	Scrub and agriculture	San Fernando Hill	Palmiste Park	Usine St. Madeline	Bellair Mudflats	Guaracara Mangrove	San Fernando Wharf	Boatyard	Cipero River
Shiny Cowbird, <i>Molothrus bonariensis</i>	X								
Carib Grackle, <i>Quiscalus lugubris</i>			X			X			
Yellow-hooded Blackbird, <i>Chrysomus icterocephalus</i>			X	X					
Euphonidae									
Trinidad Euphonia, <i>Euphonia trinitatis</i>		X							





#### 5.11.1.4 Species of Local or Regional Significance

Species of local significance include those of economic importance, those that are under a level of threat and receiving some form of protection under the law (or should be) and those which are covered by international treaties.

#### 5.11.1.5 Species of Commercial Importance

Among the finfish captured Tilapia, Mullet, Catfish, Racando (*Micropogon furnieri*), Blinch (*Diapterus rhombeus*) and Brochet (*Centropomus undecimalis*) are game fish and are usually caught on light tackle. Racando, Brochet, Tilapia and Mullet were the most commercially important species of fish noted. Honey shrimp (*Xiphopenaeus kroyeri*) was also caught within the study area. This species is listed as a popular marine species in fisheries of Trinidad and Tobago (United Nations Food and Agriculture Organization, 2010). There is some legal hunting of Iguanas and Manicou wherever they occur. There was also evidence of collection of Blue Crabs *Cardisoma guanhumi*, and Hairy Crabs *Ucides cordatus* in the mangrove around Guaracara River.

#### 5.11.1.6 Protected Species

The Conservation of Wildlife Act identifies three categories of protected species - *Endangered*, *Vulnerable* and *Rare*. No *Endangered* species were encountered during the surveys. The Scarlet Ibis, Yellow-crowned Parrot and Silky Anteater have been listed as *Vulnerable* under Schedule 4 part B. The Yellow-crowned Parrot *Amazona ocreocephala* is also listed as *Vulnerable* and is likely to be found in the study area as it is usually associated with urban areas of Trinidad. Of the species listed as *Rare* in the Act, only one species Red-capped Cardinal is expected to be present although Rufous-necked Wood-Rail may occur.

None of the species observed are listed as Environmentally Sensitive Species, under the Environmental Management Act of 2000.

None of the species observed or expected have been listed in the 2003 International Union for Conservation of Nature (IUCN) Red List of Threatened Species.

Bird species deemed to be vulnerable in Trinidad according to (Temple, 2002) include Yellow Crowned Parrot, Boat-billed Heron, Rufous Crab-Hawk, Red-capped Cardinal, Pearl Kite, Mangrove Cuckoo, Anhinga, Zone-tailed Hawk and several seedeaters (not saffron finch). The Rufous Crab Hawk is a rare resident, highly dependent on mangrove woodland. It has not however been listed as protected by the Conservation of Wildlife Act 1999. Boat-billed Heron is another rare resident which depends on secluded mangrove for breeding and has been observed breeding further south in the Roussillac Swamp.

The Peregrine Falcon is listed in Appendix 1 of the Convention on International Trade in Endangered Species of Wild Flora and Fauna (CITES). Several of the species expected and observed are listed in Appendix II of the convention including; Scarlet Ibis, Caribbean Flamingo, all birds of prey, parrots and hummingbirds, Spectacled Caiman, large lizards and snakes like the Iguana, Matte, Boa Constrictor and Anaconda. These species are listed under Appendix II of CITES because they can be confused with species genuinely threatened by international trade.



With respect to the Specially Protected Areas and Wildlife (SPAW) Protocol, the Peregrine Falcon is listed in Annex II which requires signatories to prohibit the disturbance of such species, particularly during periods of biological stress. A number of other species recommended for inclusion include the Magnificent Frigate bird, Osprey, Merlin, Scarlet Ibis and several of the herons likely to inhabit the mangrove and coastal zone.

In comparing the protected species discussed above to the field studies conducted:

- The Zone-tailed Hawk was observed, which is listed as a vulnerable species (Temple, 2002).
- Spectacled Caiman, Iguana, Matte, birds of prey including Osprey, Common Black-Hawk, and Zone-tailed Hawk, and hummingbirds including Copper-Rumped Hummingbird were observed, which are listed under CITES as predicted endangered species in the future, or look-alike species to endangered species.
- The Magnificent Frigate Bird and Osprey were observed, which are listed as recommended for inclusion under SPAW protocol to prohibit disturbance.

The National Environmental Policy requires developmental projects to result in no net loss of wetland (including mangrove). The revised policy (Environmental Management Authority, 2009) includes mangrove with 'keystone species'. The most significant freshwater wetland identified in this report is the ponds at Usine St. Madeline which are well outside of the impact zone. The trunk lines running from the Guaracara River south to the Marabella and Vistabella Rivers may impact the mangrove woodland at the mouths of these rivers. If so this mangrove must be restored to be in compliance with the National Environmental Policy.

## 5.12 Noise Quality

The TOR for the CEC application also required the monitoring of sound pressure levels and vibrations within the San Fernando Wastewater Catchment, in order to assess the baseline conditions of the environment. The environmental noise measured in the project area would also be used according to the TOR to assess the impact of the vibration and sound on the flora and fauna in the area.

Environmental noise is defined as noise emitted from anthropogenic activities such as, transport and other routine human activities which emit unwanted sound. The NPCR of Trinidad and Tobago refers to noise as sound pressure level which can be measured on an instantaneous scale and expressed as decibels (dB). Sound pressure level can also be "A-weighted" which gives a better indication of noise that would be sensitive to the human ear, it is expressed as dBA.

Noise monitoring stations were located at five sensitive receptor sites within the project area; two residential areas and, adjacent to a lift station, a health centre, and an existing wastewater treatment plant (Figure 5-35). The sound level was monitored for a 24 hour period at each site using a Quest® 2900 Sound Level Meter and a Quest® Outdoor Measurement System Kit. The equivalent ( $L_{eq}$ ) and peak ( $L_{peak}$ ) sound pressure levels were recorded at 30 minute intervals over the 24 hour period; the results are attached in **Appendix D.6**. Table 5-23 summarizes the  $L_{eq}$  at these five stations.



Figure 5-35 Air and Noise Monitoring Stations in San Fernando Wastewater Catchment Area



**Table 5-23 Sound Level Monitoring Results**

Interval	Marabella Residential Area (dBA)	La Romain Residential Area (dBA)	Harmony Hall Lift Station (dBA)	Pleasantville Health Centre (dBA)	San Fernando WWTP (dBA)
8 am	55	66	54	63	65
	55	66	54	69	64
9 am	55	71	58	61	64
	56	68	64	62	59
10 am	55	65	69	61	62
	55	67	62	61	61
11 am	54	65	65	62	66
	55	66	67	62	66
12 am	57	67	63	62	65
	54	65	66	62	64
1 pm	55	66	75	62	65
	54	64	61	61	64
2 pm	54	65	62	62	64
	54	68	55	61	64
3 pm	55	65	65	60	64
	55	66	57	62	63
4 pm	56	66	57	61	63
	57	83	55	62	63
5 pm	56	72	56	64	63
	55	67	54	63	63
6 pm	58	67	56	68	63
	56	65	55	63	63
7 pm	55	65	55	63	62
	53	65	55	62	63
8 pm	56	67	53	62	63
	53	67	55	62	62
9 pm	53	63	57	62	62
	52	64	59	60	63
10 pm	54	62	52	60	63
	54	62	51	61	63
11 pm	53	60	50	61	63
	54	59	48	64	62
12 am	54	60	49	57	62
	54	61	52	55	62
1 am	54	56	50	56	63
	53	56	48	54	63
2 am	55	55	52	55	63
	57	54	51	53	63

**Table 5-23 Sound Level Monitoring Results (continued)**

Interval	Marabella Residential Area (dBA)	La Romain Residential Area (dBA)	Harmony Hall Lift Station (dBA)	Pleasantville Health Centre (dBA)	San Fernando WWTP (dBA)
3 am	55	51	54	53	63
	54	51	55	60	62
4 am	55	54	57	55	62
	54	58	73	55	63
5 am	54	57	70	54	64
	55	62	71	55	64
6 am	56	62	68	57	64
	56	65	71	59	65
7 am	58	65	66	59	64
	56	65	57	60	64

The average  $L_{eq}$  was highest in La Romain Residential area at 67 dBA in the day period as defined in the First Schedule of the NPCR. The San Fernando WWTP however had the highest  $L_{eq}$ , recorded at 63 dBA in the night period. The average readings are presented in Table 5-24. As illustrated, the  $L_{peak}$  attained a level of 123 dB at the Pleasantville Health Centre. This site would fall under Zone III or General Area according to the NPCR where the  $L_{peak}$  should not exceed 120 dB during the day-time; this was the only survey station that exceeded this limit. The  $L_{peak}$  limit for the night-time is 115 dB; the environmental noise recorded at all five receptor stations was below this limit.

The San Fernando WWTP is considered an industrial site according to the EMA and the TCPD. As a result the limits defined for Zone I or Industrial Areas in the First Schedule of the NPCR would apply. The  $L_{eq}$  should not exceed 75 dBA at anytime; the environmental noise at the San Fernando WWTP stayed within this limit. The  $L_{peak}$  according to the regulations must not surpass 130 dB and based on the sampling at the plant this limit was not exceeded.

**Table 5-24 Average  $L_{eq}$  and  $L_{peak}$  Measurements for Noise Sampling**

Sound Pressure Level	Period	Marabella Residential Area (dB)	La Romain Residential Area (dB)	Harmony Hall Lift Station (dB)	Pleasantville Health Centre (dB)	San Fernando WWTP (dB)
$L_{eq}$	8 am to 8 pm	55	67	60	62	63
$L_{peak}$	8 am to 8 pm	103	115	113	123	119
$L_{eq}$	8 pm to 8 am	55	60	57	58	63
$L_{peak}$	8 pm to 8 am	102	115	113	111	117



The instantaneous increase in sound pressure levels at and around the sample sites may be attributed to:

- Sound from vehicles passing along roadways.
- Recreational and social activities including bars.
- Construction activities.

### 5.13 Ambient Air Quality

Air pollution is described as the emission of any substance categorised as an air pollutant according to the draft APR of Trinidad and Tobago. For this project only the particulate matter was recorded, this included particles with diameters measuring 10 micrometres or less (PM<sub>10</sub>), particles with diameters less than or equal to 2.5 micrometres (PM<sub>2.5</sub>) and the total suspended particles (TSP) which are less than 100 micrometres in diameter. The TOR required that monitoring of air quality be done in the area around the proposed WWTP site.

The survey equipment was set up at the same sites as the noise monitoring stations. The Airmetrics Minivol® was used to measure the TSP and PM<sub>2.5</sub> and the TSI Dust Trak® was used to measure PM<sub>10</sub> concentrations. The Minivol was set to collect samples over a 24 hour period; the air streamed through the equipment and a filter collected the particles with diameters less than 100 µm (micrometers) for TSP and less than 2.5 µm (micrometres) for PM<sub>2.5</sub>. These were then weighed by ROSE Environmental Limited to determine the amount of particles in the atmosphere. Table 5-25 represents the results of this sampling event in comparison to the maximum permissible levels defined in the Second Schedule of the draft APR.

**Table 5-25 TSP and PM<sub>2.5</sub> Air Quality Results in San Fernando Wastewater Catchment**

Site	Weight of TSP (µg/m <sup>3</sup> )	Draft APR TSP Limit (µg/m <sup>3</sup> )	Weight of PM <sub>2.5</sub> (µg/m <sup>3</sup> )	Draft APR PM <sub>2.5</sub> Limit (µg/m <sup>3</sup> )
Marabella Residential Area	89.7	150	64.2	65
La Romain Residential Area	55		19.4	
Harmony Hall Lift Station	36		48.6	
Pleasantville Health Centre	54.5		13.1	
San Fernando WWTP	66.4		22.1	

PM<sub>10</sub> concentrations were measured at one minute intervals over a 24 hour period. The data report sheets are appended in **Appendix D.7**. The average PM<sub>10</sub> values for each sample site are as follows:

- Marabella Residential Area – 168 µg/m<sup>3</sup>
- La Romain Residential Area – 35 µg/m<sup>3</sup>
- Harmony Hall Lift Station - 33 µg/m<sup>3</sup>
- Pleasantville Health Centre - 25 µg/m<sup>3</sup>
- San Fernando WWTP - 56 µg/m<sup>3</sup>



The maximum permissible limit for  $PM_{10}$  is  $75 \mu\text{g}/\text{m}^3$  for a 24 hour period according to the Second Schedule of the draft APR. All the sample sites were within these limits, except the  $PM_{2.5}$  level almost surpassed the regulation.

Analysis of the data proved that the Marabella Residential Area has a high level of pollutants in the atmosphere and this can result in detrimental effects to human health. Research done at the United States of America Environmental Protection Agency (USEPA) concludes that humans exposed to high levels of  $PM_{10}$  and  $PM_{2.5}$  can suffer from breathing and respiratory illnesses, damage to lung tissue, cancer and premature death (U.S. Environmental Protection Agency). The high concentration of particles in the air is presumed to be a product of petroleum production in the nearby Petrotrin refinery.

The  $PM_{2.5}$  values at the San Fernando WWTP even though within the standards are still relatively high. This may be attributed to the fact that a large portion of the WWTP is unpaved and drought conditions were experienced at the time of sampling. These factors would have exacerbated the dust and increased air particles. The values recorded for TSP and  $PM_{2.5}$  within the La Romain Residential Area may have been affected by nearby roadwork. Investigation of the baseline conditions at this locality showed that it is a very active area with a lot of businesses making it a common and populated area.

Overall, some of the causes of elevated air particulate concentrations in the San Fernando Wastewater Catchment Area likely include:

- Vehicular emission.
- Construction activities.
- Refinery operations.
- Bush fires, which were widespread around the sampling time.



## 6. Social Environmental Conditions

### 6.1 Introduction

The social or human environment is defined as any physical space in which humans occupy whether for living, working, recreation or business purposes. The baseline assessment of the social environment will be discussed in this report under the following headings:

- History
- Land Use
- Archaeology
- Employment
- Recreation
- Public Institutions
- Population Demographics
- Socio-Economic
- Traffic

These themes will be discussed and used in conjunction with the findings of the biophysical survey to determine the potential impact the San Fernando Wastewater Project will have on the biological and human environment.

### 6.2 Study Area

The size of the study area is approximately 42 km<sup>2</sup> and this was divided into several subcatchments (Figure 3-24) by AECOM based on natural topography, drainage and physical boundaries. The demarcation of subcatchments is mainly for construction purposes where the work can be phased to ensure maximum cost-to-construction benefits.

The San Fernando Wastewater Catchment Area illustrated in (Figure 3-1) is divided into three administrative areas; San Fernando City Corporation, Penal/Debe Regional Corporation and Princes Town Regional Corporation. These administrative areas are broken up into communities and then subdivided into enumeration districts (ED) by the Central Statistical Office (CSO) of the Government of Trinidad and Tobago. An enumeration district is described as “a geographical area comprising approximately one hundred and fifty to two hundred (150 to 200) households” (Central Statistical Office, 2002). The classification of each enumeration district within the administrative areas is described in Section 6.7, while specific EDs are given a description based on the community it is sited in. All the EDs of the San Fernando City Corporation are within the project boundaries of the San Fernando Wastewater Catchment area. However, not all of the EDs within the Penal/Debe and Princes Town Regional Corporations lie within the study area.

The current population of the San Fernando Area is estimated at 90,200 based on housing counts conducted by AECOM. The total population recorded in the 2000 Census was 89,200 (Central Statistical Office, 2002). The San Fernando WWTP and Collection System have to be designed until the year 2035; the population is projected to increase to 111,600 by this time.





### 6.3 Methodology

The TOR of the CEC application outlines specific factors that must be included in the social impact assessment (SIA) of this project. Broadly, the objectives are to: describe the human and socio-economic environment of the San Fernando Wastewater Catchment and to assess the potential impacts of construction, operation and decommissioning of the facility and associated infrastructure on the human and socio-economic environment.

The specific purpose of this part of the study as stated in the TOR is to:

- Describe socio-demographic characteristics of the population including; population size and socio-economic indicators.

A social survey was conducted by sub-consultant Market Facts and Opinions (2000) Limited (MFO) specifically targeting residents in areas that would be most affected by the San Fernando Wastewater Project as discussed in Section 6.13. Investigations into the historical and present-day characteristics of the human environment were done by AECOM from inception of the project until the completion of this report.

The Census statistics were also used for the social study. Interpretation of the defined boundaries of the CSO administrative areas were compared to that of the subcatchments of the proposed wastewater collection system design. Table 6-1 demonstrates the project subcatchments contained within each municipality in the project area. **Appendix E.1** contains a list of the communities for each municipality and subcatchment pertinent to the San Fernando Wastewater Project.

**Table 6-1 Subcatchments within Administrative Areas**

Administrative Area/Municipality	Subcatchment
San Fernando City Corporation	San Fernando South
	Green Acres
	Bel Air-Gulf View
	Vistabella
	Marabella
	Tarouba-Cocoyea
	Cocoyea South
	Pleasantville-Corinth
Penal/Debe Regional Corporation	La Romain South
	La Romain North
	La Romain Central
	Palmiste South

**Table 6-1 Subcatchments within Administrative Areas (continued)**

Administrative Area/Municipality	Subcatchment
Penal/Debe Regional Corporation	Picton
	Duncan Village
	Union Hall
Princes Town Regional Corporation	Retrench-Golconda
	Ste. Madeline

Secondary data was obtained from CSO and other external sources to support the findings of MFO and AECOM's study to further accomplish the objectives of the assessment.

## 6.4 Historical Development of Study Area

The history of the San Fernando Wastewater Catchment is important in explaining the existing infrastructure and services offered to the residents and businesses of the area. The area was named 'Anaparima' by the first settlers of the town; the native Amerindians. This term translated means single hill and was designated after what is now the San Fernando Hill. In the 1700s San Fernando was a fishing village and was only developed by the Spanish Governor in 1792.

In the 1800s, agriculture was the main industry in San Fernando where sugar cane, cotton and coffee were cultivated (Trinidad Guardian, 1998). The slaves, indentured labourers and Europeans settled in the area and as a result formed an ethnically diverse population. The first railway in Trinidad was constructed in San Fernando by a Scottish planter to transport produce from his sugar plantation to the wharf at San Fernando, named Kings Wharf (Ottley, 1971). The line was known as the Ciperio Tramway and ran along the western coast of San Fernando. The Ciperio Tramway was eventually absorbed by the Trinidad Government Railway (TGR) System and is now the proposed route of the Gulf Sewer Trunk expected to run from Guaracara River southward to the San Fernando WWTP.

The twentieth century brought the oil industry to the San Fernando Area, despite the first oil wells being drilled within the project area in 1866. These wells were not productive and oil exploration moved further south of Trinidad. Consequently San Fernando became the transport hub and expanded as companies servicing the oil industry set up in the area.

The villagers of San Fernando were of the opinion at this time that the Colonial Government abandoned the town since electricity was only installed in 1923, 28 years after Port-of-Spain (The Energy Chamber of T&T). The existing wastewater collection, treatment and disposal system was built in the 1960s and is owned and operated by WASA. The system was never upgraded since and this project seeks to accomplish this.



## 6.5 Land Use

The land use of the study area is described in Section 5.9.1 in terms of the biological environment. The land use will be discussed in this section according to human activity, categorised as follows:

- Residential
- Agriculture
- Light Industry
- Commercial

The residential land use includes all space where buildings are erected for persons to live; comprising vacant, closed, private and non-private dwellings as defined in the 2000 Census (**Appendix E.2**). Agriculture land spaces are all areas where land is cultivated with any crop or where animals are reared both on a small and large scale. Light industry is where the property is used for manufacturing of goods that are consumer-oriented and raw materials used are lightly processed; examples include clothing manufacture and drilling companies. Commercial land spaces are all the areas occupied by buildings designated for offices, shopping centres and restaurants.

The subcatchments within the San Fernando Wastewater Catchment were subdivided according to the type of activity that predominantly occurs in the area. Figure 6-1 depicts the land use per subcatchment and the main human activity within the area. In some cases the area was classified based on the activity the community is popular for. An example is the Bel Air-Gulf View subcatchment which is well known for Gulf City Mall and other commercial activities taking place within the vicinity. A more detailed land use map is presented in Section 5 as Figure 5-26.

Based on this land classification, the San Fernando Wastewater Catchment area is occupied predominantly by residential communities that have been developed both by private entities and the government sector. The proposed San Fernando Wastewater Collection System will service all the buildings within the wastewater catchment including future developments. Table 6-2 presents a list, prepared by AECOM of these new and proposed residential developments that would be serviced. In the case of sites where sewer design is incorporated, the San Fernando Wastewater Collection System design would make provisions for integrating this in the sewer design.

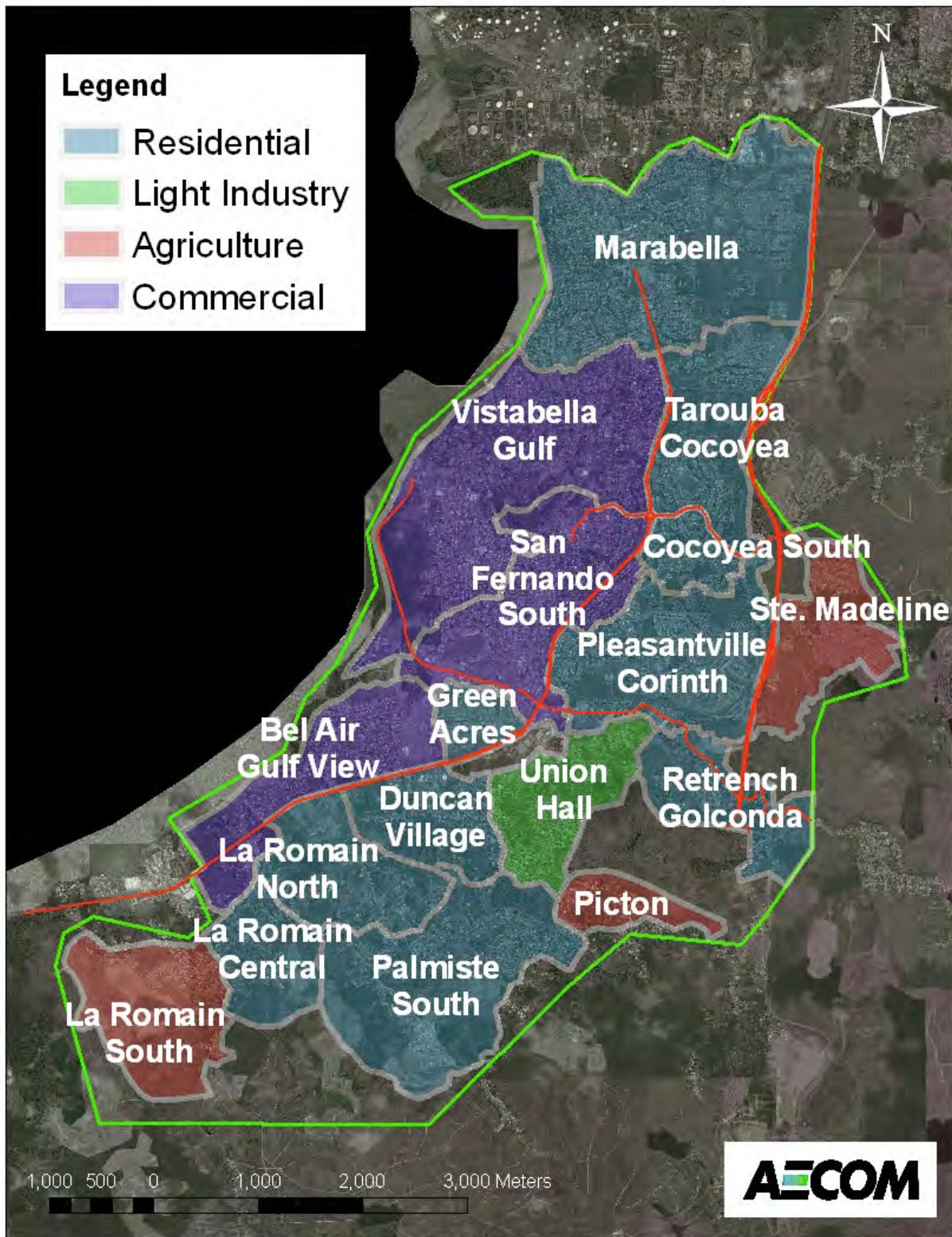


Figure 6-1 Land Use in San Fernando Wastewater Catchment based on Human Activity

**Table 6-2 New and Proposed Housing Developments in the San Fernando Wastewater Catchment**

Name of Development	No. of Lots	Construction Status
Boyack Development	42	Presently under construction
Corinth Housing Development	283	Construction nearly complete
Golconda Residential Development	270	Presently under construction
Hermitage Development	340	Presently under construction
Hosein Development	8	Presently under construction
La Fortune Housing Development	22	Presently under construction
La Romain Residential Development	915	Presently under construction
Lunarstar Development	21	No construction underway
Palmiste Development Phase I	144	Presently under construction
Rahaman's Development Phase III	18	No construction underway
Retrench (Hill Crest) Housing Development (Housing Development Corporation)	360	Construction nearly complete
Retrench Development	10	No construction underway
Rostam and Tahiroon Doman Development	7	No construction underway
St. Joseph Gardens	162	No construction underway
Tarouba South Phase IV	141	Presently under construction
Tarouba South Phase V	51	Presently under construction
UDECOTT Garden Apartments	unknown	No construction underway
Z.R. Meah John Development	unknown	No construction underway



## 6.6 Archaeology Sites

There are over 300 archaeological sites in Trinidad designated by the Archaeological Committee of Trinidad and Tobago. This society has now been absorbed by the National Trust under the Ministry of Community Development, Culture and Gender Affairs. The policy of the organisation is to conceal the exact location of the sites for preservation purposes. The Committee classify the sites according to the level of protection stipulated; this classification is illustrated in Table 6-3. The development plans for the project, in this case the sewer layout, must be examined by the appropriate body in order to ensure conservation of the archaeological sites.

In the first public consultation discussed in Section 7, a member of the Archaeological Committee of Trinidad and Tobago was present to observe the proposed plans for the wastewater catchment area. Concurrent to this, discussions with the past chairman of the Committee distinguished some of the archaeological sites within the study area. The sites identified by the Archaeology personnel are portrayed in Figure 6-2. All of these spots are within the San Fernando City area and presumably enfold indicators of Amerindian culture and the colonial history of the City. The impact of the San Fernando Wastewater Project to these sites will be discussed in Section 8.

**Table 6-3 Classification of Archaeological Sites**

Site Class	Definition	Notes
Class A	Protected Site. Should remain undisturbed	No Class A sites are known to exist within project area.
Class B	Important Site. Demolition can start only after an excavation has been done to retrieve any archaeological remains.	<ul style="list-style-type: none"><li>- Harris Promenade Site</li><li>- Carib Street Site</li><li>- Golconda (Teak Plantation) Site</li></ul>
Class C	On commencement of construction someone must be employed to collect samples of earth from excavated / disturbed areas or that which will be occupied by a permanent works.	<ul style="list-style-type: none"><li>- Tarouba Sites</li><li>- Spring Vale Site</li><li>- Golconda 2 Site</li><li>- Gulf City Mall Site</li><li>- Victoria Village Site*</li></ul>
Class D	Possible Site. Anecdotal Evidence. Location no longer known due to loss of records etc.	<ul style="list-style-type: none"><li>- San Fernando Hospital ( west side)</li><li>- Ciperio River Mouth</li><li>- Mount Moriah Road</li></ul>

Note: \*Victoria Village Site may be in close proximity to Ciperio Trunk Main



Figure 6-2 Archaeological Sites in San Fernando Wastewater Catchment



## 6.7 Employment

Employment in the San Fernando Wastewater Project Area is generally available in all sectors but is most prevalent in the service division. The main industry within the study area is petroleum; Petrotrin Oil Refinery and many other oil drilling and exploration companies are established in the area. The exact percentage of San Fernando residents employed in this sector is uncertain.

The CSO 2000 Census investigated the number of businesses existing in each administrative district and is provided in Table 6-4.

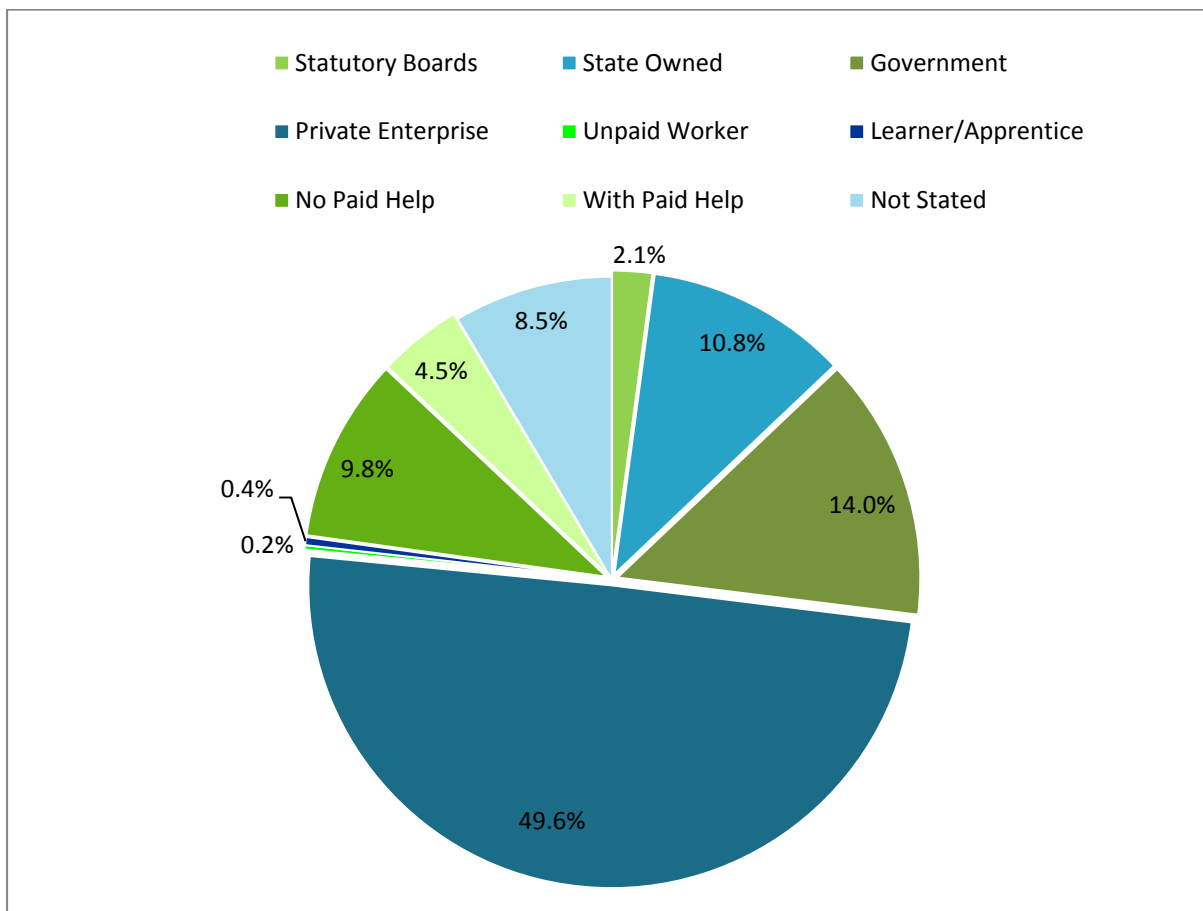
**Table 6-4 Businesses in San Fernando Wastewater Catchment (Central Statistical Office, 2002)**

Administrative Area	Enumeration District/Community Description	Number of Business Places
San Fernando City Corporation		3,102
Penal/Debe Regional Corporation	La Romain	216
	Duncan Village	204
	Golconda	35
	Rambert Village	29
	Palmiste	6
	Canaan Village/Palmiste	15
	Esperance Village	17
	Picton	35
	Hermitage Village	62
	Phillipine	30
Princes Town Regional Corporation	Diamond	30
	Golconda	18
	Corinth	45
	Ste. Madeline	48
<b>TOTAL</b>		<b>3,892</b>





In 2000, there were 3892 businesses recorded in the San Fernando Wastewater Catchment. Extensive commercial expansion has occurred in the study area between 2000 and 2010 specifically in the Duncan Village, Gulf View, La Romain, Vistabella and Marabella subcatchments. This has therefore provided ample job opportunities in the area. The 2000 Census also documented the worker status of the residents in the San Fernando City Corporation as depicted in Figure 6-3.



**Figure 6-3 Status of Employment in San Fernando City Corporation (Central Statistical Office, 2002)**

The majority of the San Fernando City Population which comprises the subcatchments listed in Table 6-1 is employed in private enterprises. The 2000 Census also subdivided the employment records into groups of general occupations and industry. The ratio of the population in each group is presented in Figure 6-4 and Figure 6-5. Additional updated statistics for the project area are reviewed in Section 6.13.

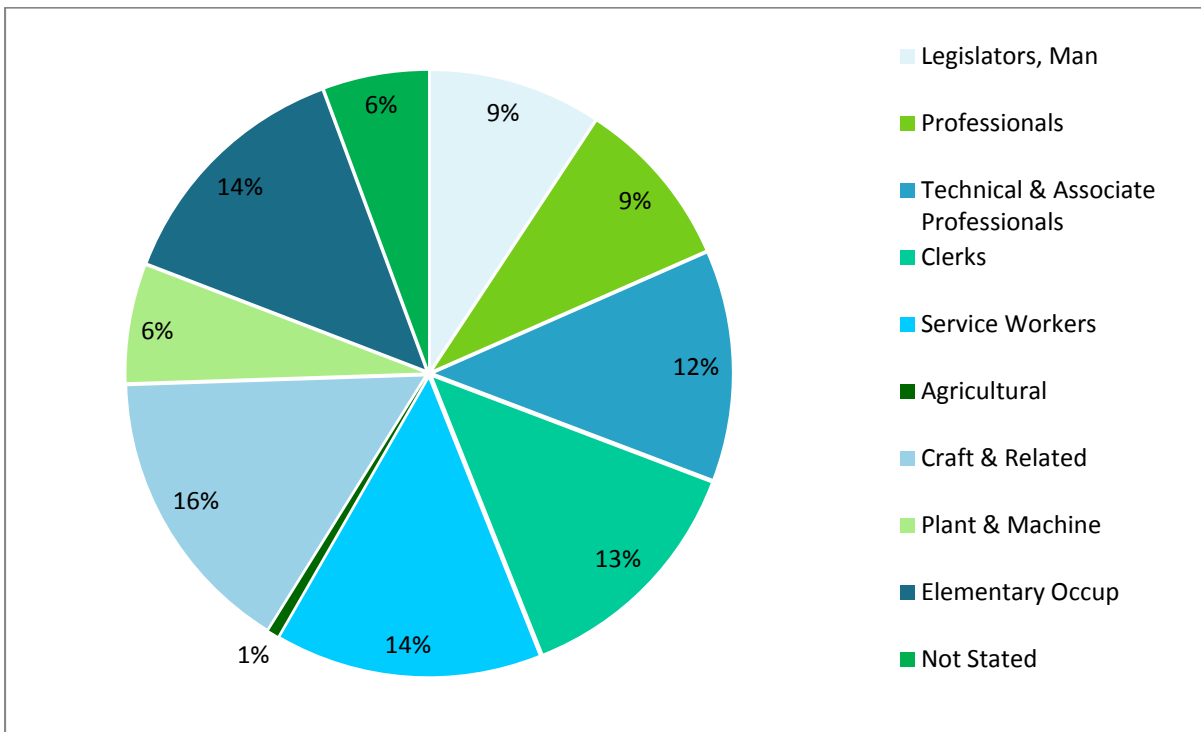


Figure 6-4 General Occupational Groups (Central Statistical Office, 2002)

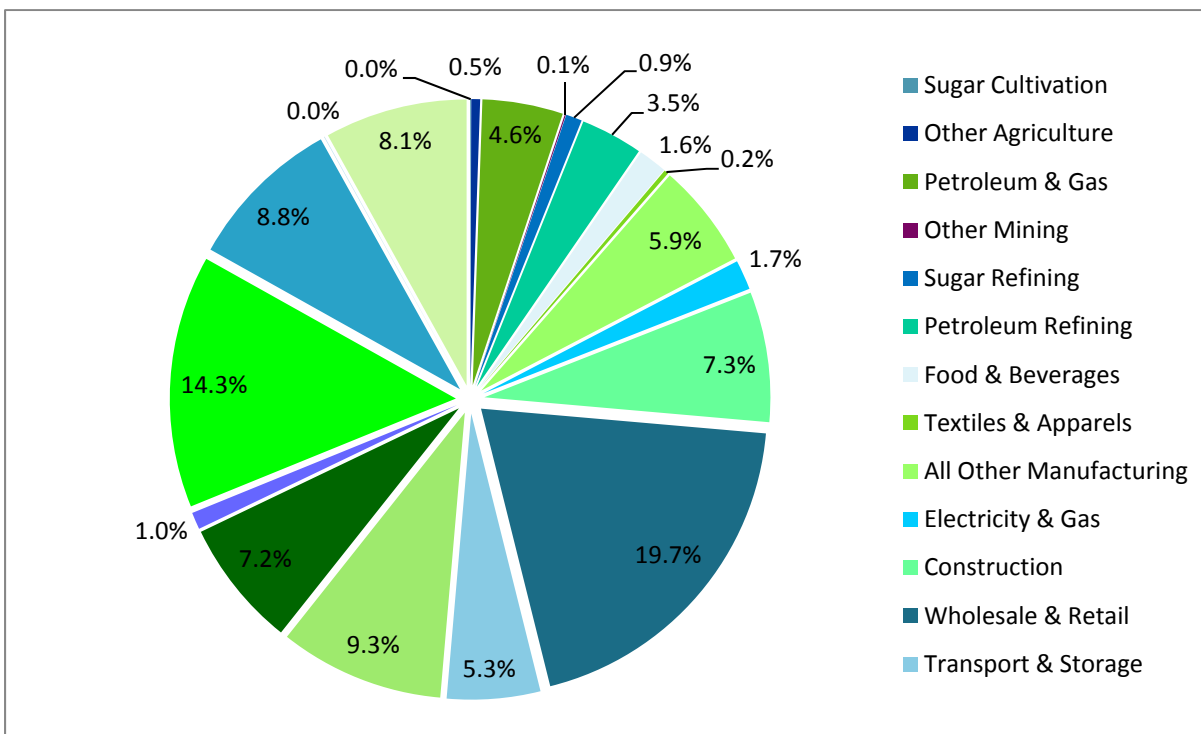


Figure 6-5 Residents Employed within Industry Sector (Central Statistical Office, 2002)



## 6.8 Recreational Activities

Recreational activities for the purpose of this study were defined as any hobby that the residents enjoyed for leisure or play. This included: parks, football grounds and clubs. Figure 6-6 illustrates the recreational facilities in the study area. The San Fernando Wastewater Collection System is not expected to affect any of these structures. Further information on recreational activities obtained through the social survey is discussed in Section 6.13.

## 6.9 Public Buildings and Institutions

The San Fernando Wastewater Project Area has a significant number of public buildings and institutions due to the history of the city and the expansive development that has occurred in recent times. Facilities of the protective services in Trinidad and Tobago and health centres can be considered public institutions; however, these will be discussed in further detail in Section 6.12.1 and 6.12.4. In this segment of the report, the following services will be discussed:

- Schools
- Community Centres
- Courts
- Libraries

### 6.9.1 Schools

There are a considerable number of schools in the San Fernando Wastewater Project area. They range from primary and secondary schools funded by the Trinidad and Tobago Government to those funded by church bodies and other private entities. There are also many tertiary institutions instructing on different subjects and trades. A list of all the primary, secondary and tertiary establishments in the San Fernando Wastewater Catchment is appended in **Appendix E.3**. These schools accommodate students within the project area and other communities outside of the San Fernando Wastewater Catchment boundaries. The student populations were used to give an estimate of the design flows for schools in the area.

### 6.9.2 Community Centres

The Ministry of Community Development, Culture and Gender Affairs has established two community centres within the project boundaries, these are the Vistabella Regional Complex and Ste. Madeline Regional Complex. Apart from these, there are also community centres that were established by the respective community council and leaders, examples of these are:

- Pleasantville Community Centre
- Cocoyea Community Centre
- Mon Repos Community Centre

The purpose of these centres is broadly to facilitate the members of the particular communities. The trend is that any person or organisation can rent the centre at a cost. Conversely, there are normally events and activities undertaken by the Ministry of Community Development, Culture and Gender Affairs and Corporation hosted at the buildings. These include; trade classes, homework supervision and other activities initiated by the relevant agency. These buildings would be serviced in the proposed San Fernando Wastewater Collection System Design.



### 6.9.3 Courts

The San Fernando area only has one supreme and magistrate court which services the population of the Wastewater Catchment. The San Fernando Supreme Court and the San Fernando Magistrate Court are both located between Knox and Harris Street on Harris Promenade. The law of Trinidad and Tobago requires that all criminal matters occurring in a certain area must be heard in the judicial court closest to the site in which it occurred. Therefore only offenses that have taken place within or around San Fernando will be tried in this courtroom.

### 6.9.4 Libraries

A library is considered a public building since it is available for use by all members of the public. There are two libraries that would service the San Fernando Wastewater population; Carnegie Free Library located on Harris Promenade and Debe Public Library. The Debe Public Library is not located within the San Fernando Wastewater Project boundaries, but would be accessed by residents living within the catchment area.



Figure 6-6 Recreational Places in San Fernando Wastewater Catchment



## 6.10 Population Demographics

Population demographics are usually described as the classification of statistics of a populace based on certain characteristics. The demographics are discussed in this report based on the categories of age, religion and ethnicity. The data is based on the Census 2000 data, which encompassed all communities within the San Fernando Wastewater Project area.

The 2000 Census, as described in Section 6.2 was conducted for the whole of Trinidad and Tobago. Each municipality was divided into communities and then these were further separated into EDs based on the classification described in Section 6.2. The 2000 Census data used for this project was taken per community that fell within the catchment boundaries.

### 6.10.1 General

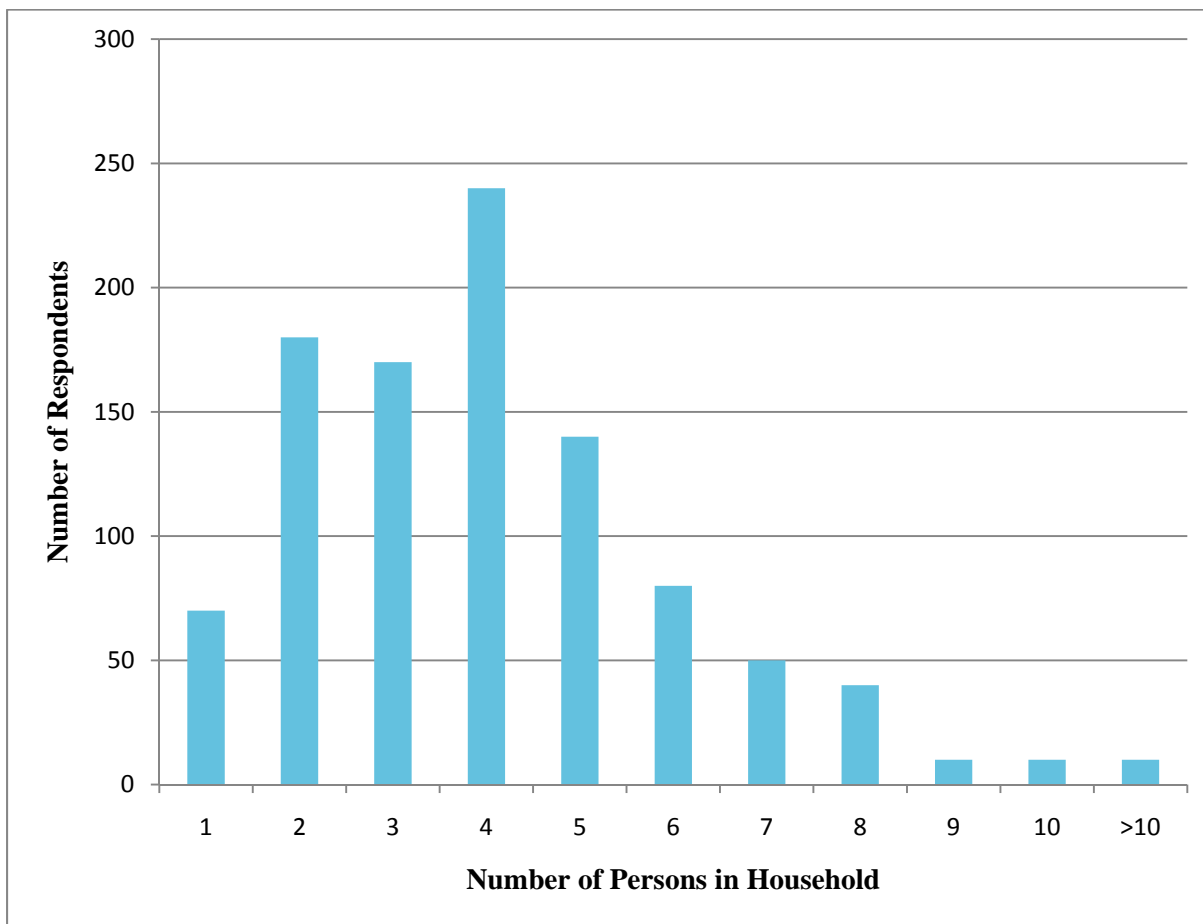
The 2000 Census Data for the project area documented a total population count of 89,199 for the San Fernando Wastewater Catchment. Table 6-5 lists the population count and the breakdown by municipality for the project area; this includes both sexes and all age groups.

**Table 6-5 Population Count by Regional Corporation**

Municipality	Communities	2000 Population
San Fernando City Corporation	21	55,419
Princes Town Regional Corporation	3	4,280
Penal/Debe Regional Corporation	11	29,316
<b>TOTAL</b>		<b>89,015</b>

The annual growth rate of the population was suggested in WASA's Water and Wastewater Master Plan; which is attached in **Appendix E.4**. The projected population based on these growth rates for 2009 and 2010 was estimated at 93,873 and 94,418, respectively (**Appendix E.4**).

Satellite imagery from 2009 was used to manually count buildings in the project area. This was used to calculate the population for the project area where the average occupancy was assumed to be 3.5 persons per dwelling. This figure was proved to be accurate based on findings from the social survey (Figure 6-7). The manual housing count method averaged the population of 2009 to be 90,200 for the project area. This value was used to determine the estimated design population for the year 2035 using the Master Plan growth rates; this value was computed to 101,195 persons in the study area. These calculations are appended in **Appendix E.4**.



**Figure 6-7 Number of Persons in Household, Social Survey 2010**

### 6.10.2 Age

The age distribution of the San Fernando Wastewater Catchment was obtained from the 2000 Census and the social survey conducted. As illustrated in Figure 6-8, the highest age group in both sexes is the 20 to 35 year bracket. The age structure of the San Fernando Municipality is typical of slow growth where the younger and older age groups comprise a smaller percentage of the population. In comparison, a higher percentage of the population is within the 20 to 65 year age range. This configuration was possibly due to a 'baby boom' that has since subsided.

The social survey done for this project depicts similar results where the majority of the population was between the ages of 20 to 65, with the 20 to 44 age bracket having a higher percentage. The age distribution of the social survey is slightly different and has more characteristics of a negative growth since the younger and older age groups comprise a considerably lower percentage of the population.

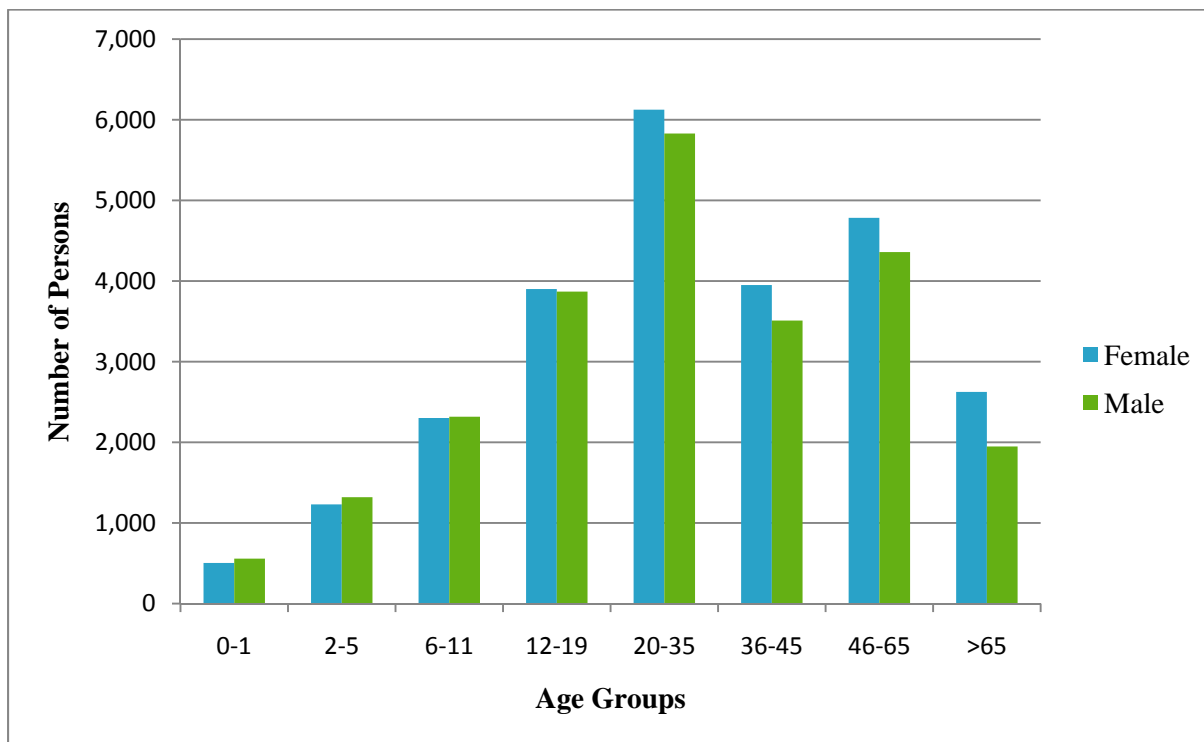


Figure 6-8 Age-Sex Distribution in San Fernando City Corporation (Central Statistical Office, 2002)

### 6.10.3 Religion

The religious composition of San Fernando City Corporation is composed chiefly of the religions listed in Figure 6-9. The most popular religious group are Roman Catholics, followed by members of 'Other' religions not listed in the Census. Anglicans comprise the third largest religious sector with approximately 11% of the surveyed population. Most of the churches are located within the boundaries of the City of San Fernando therefore residents of surrounding communities that are expected to be serviced through the San Fernando Wastewater Collection System would partake in the religious activities in the City centre.



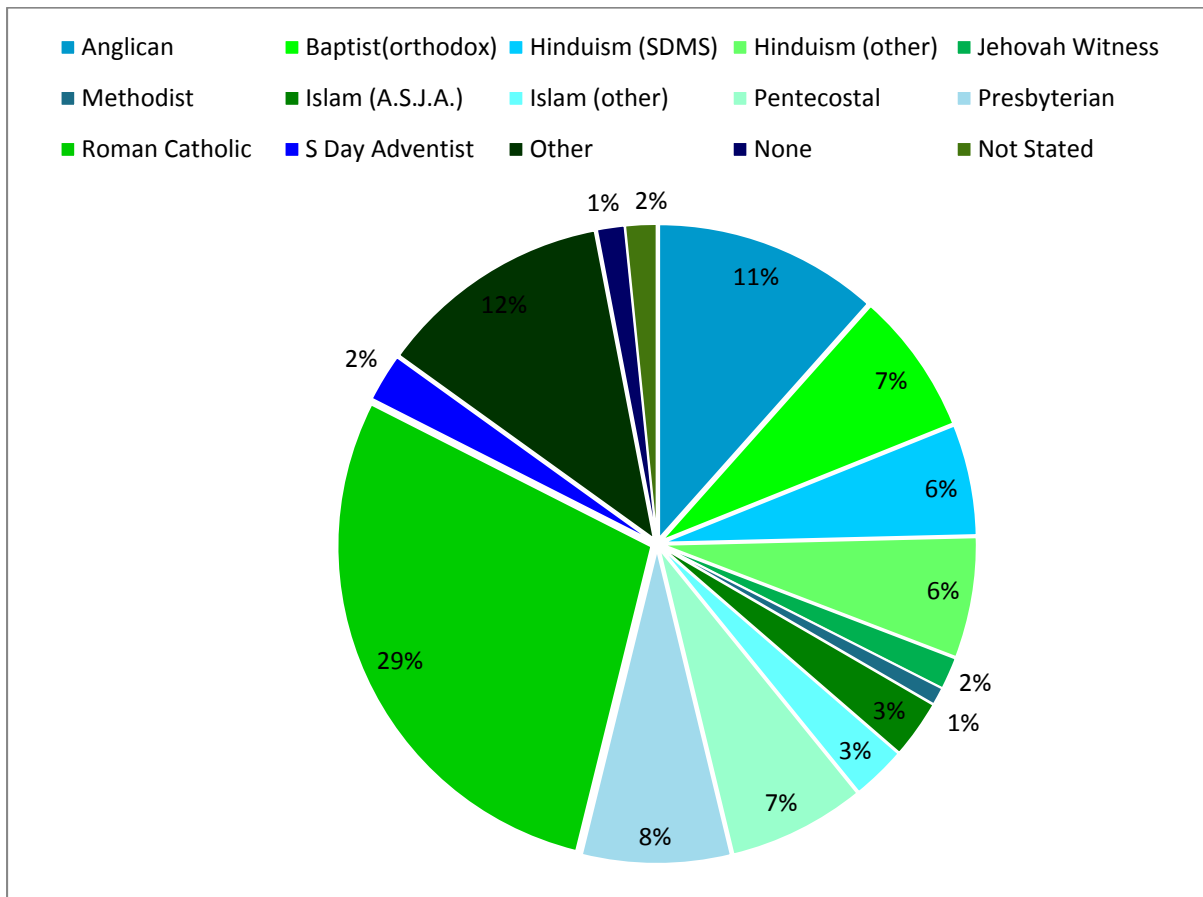
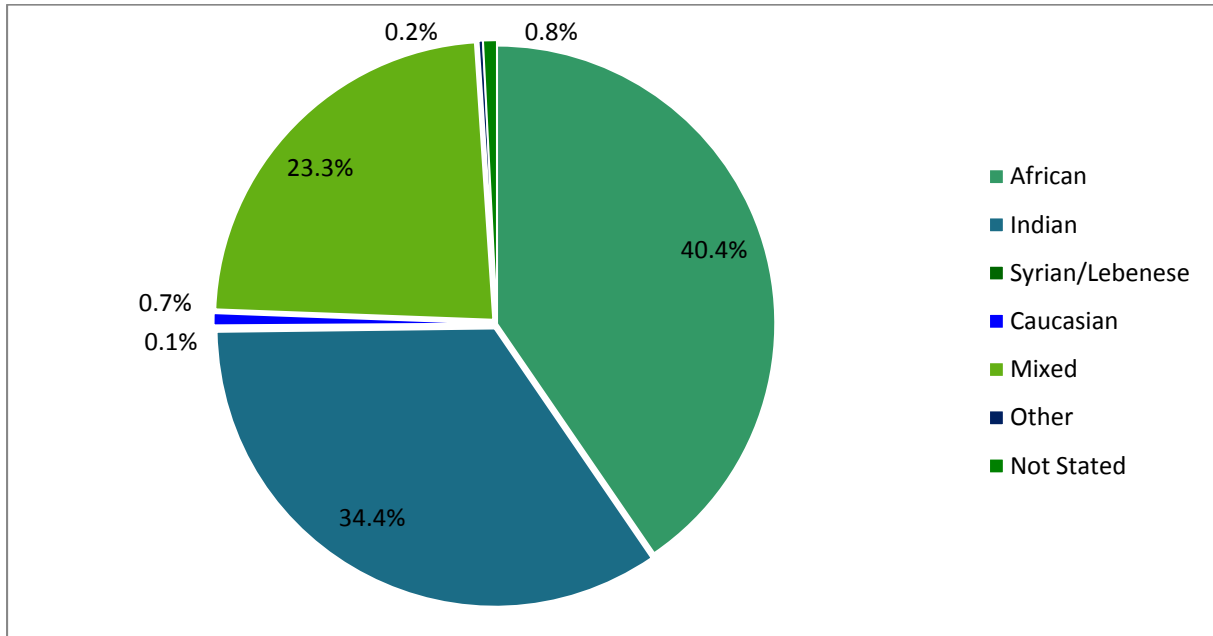


Figure 6-9 Religious Composition of San Fernando Municipality (Central Statistical Office, 2002)

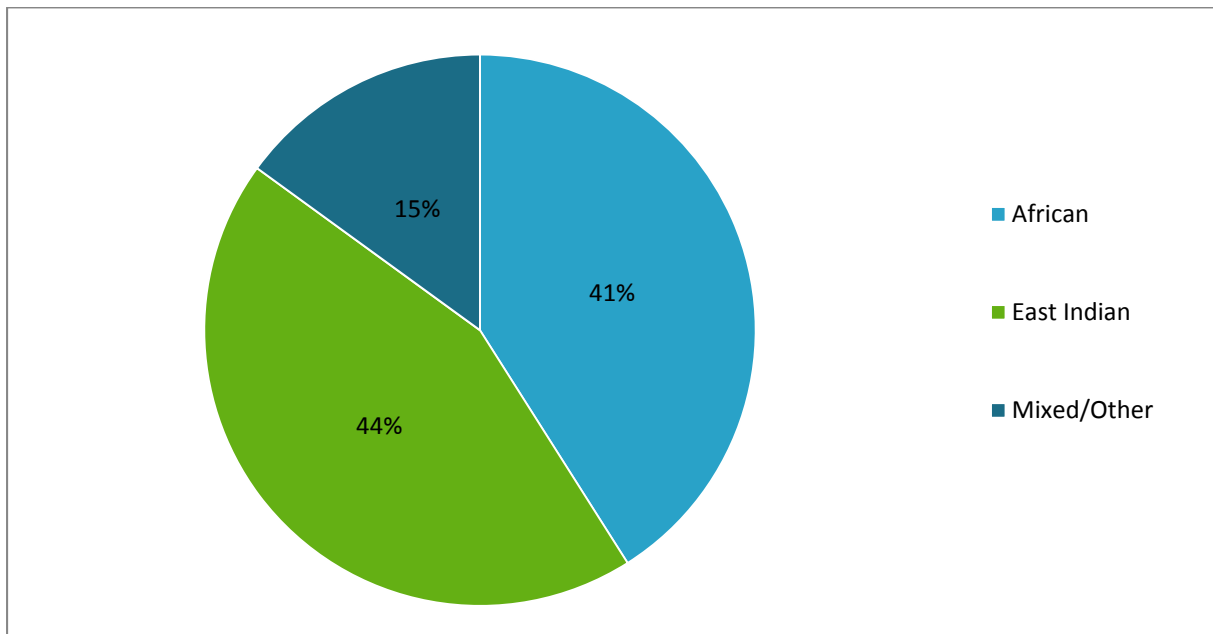
#### 6.10.4 Ethnicity

The ethnic structure of the San Fernando Wastewater Catchment comprises of 40% Africans, 34% Indian and 23% Mixed (Figure 6-10). The other residents are Caucasian, Syrian/Lebanese and of ‘Other’ ethnic groups.



**Figure 6-10 Ethnic Composition of San Fernando City (Central Statistical Office, 2002)**

The social survey 2010 also explored ethnic statistics within the communities that would be sewered. These however were limited to the racial classification of the respondent and not necessarily all the residents, Figure 6-11 describes the ethnicity of the respondents of the social survey.



**Figure 6-11 Ethnicity of Respondents of Social Survey 2010**



## 6.11 Quality of Life

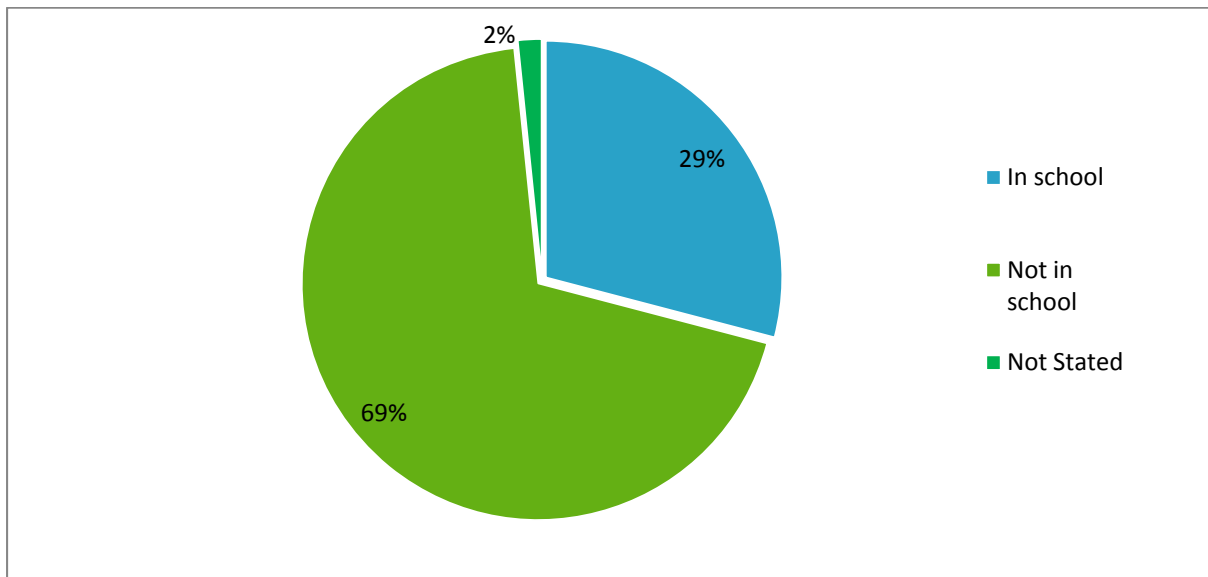
The quality of life is defined by the United Nations as a “notion of human welfare (well being) measured by social indicators rather than by “quantitative” measures of income and production” (UN Statistics Division). The quality of life is a direct representation of the socio-economic status of the population. The 2000 Census explored the statistics for socio-economic characteristics such as education and housing.

The social survey executed for the San Fernando Wastewater Project used a point system to identify the socio-economic status. The different occupations, levels of education and household items were ranked and calculated to place a numerical value to the quality of life of the dwelling and respective individuals. The rank and calculations are attached in **Appendix E.5**.

This section will discuss the socio-economic characteristics as a means of classifying the quality of life of the population. These indicators include; employment (Section 6.7), education, housing, water, sewer, electricity, telecommunications and transport. The availability of social services is also an indicator of the quality of life of a society; however, this will be discussed in Section 6.12.

### 6.11.1 Education

The level of education of a population is a critical indicator of the quality of life because it clearly depicts the production of a society and the economic vitality of the populace. The schools in the project area are discussed in Section 6.9.1. The 2000 Census data revealed approximately 69% of the surveyed area were not attending school during that period (Figure 6-12). The social survey of 2010 found that this figure decreased to 51% for this year.



**Figure 6-12 Status of Schooling for the period 2000 (Central Statistical Office, 2002)**



The 2000 Census also explored the level of education attained by the population, as well as the highest exam passed by the residents. This data is presented in Figure 6-13 and Figure 6-14.

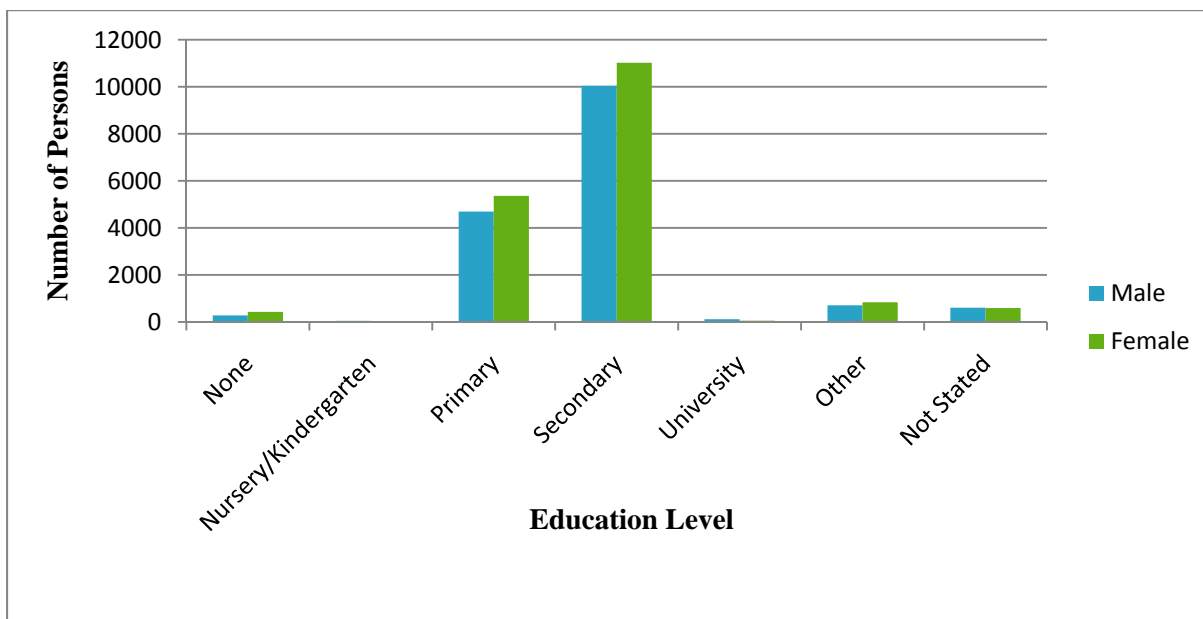


Figure 6-13 Highest Educational Attainment (Central Statistical Office, 2002)

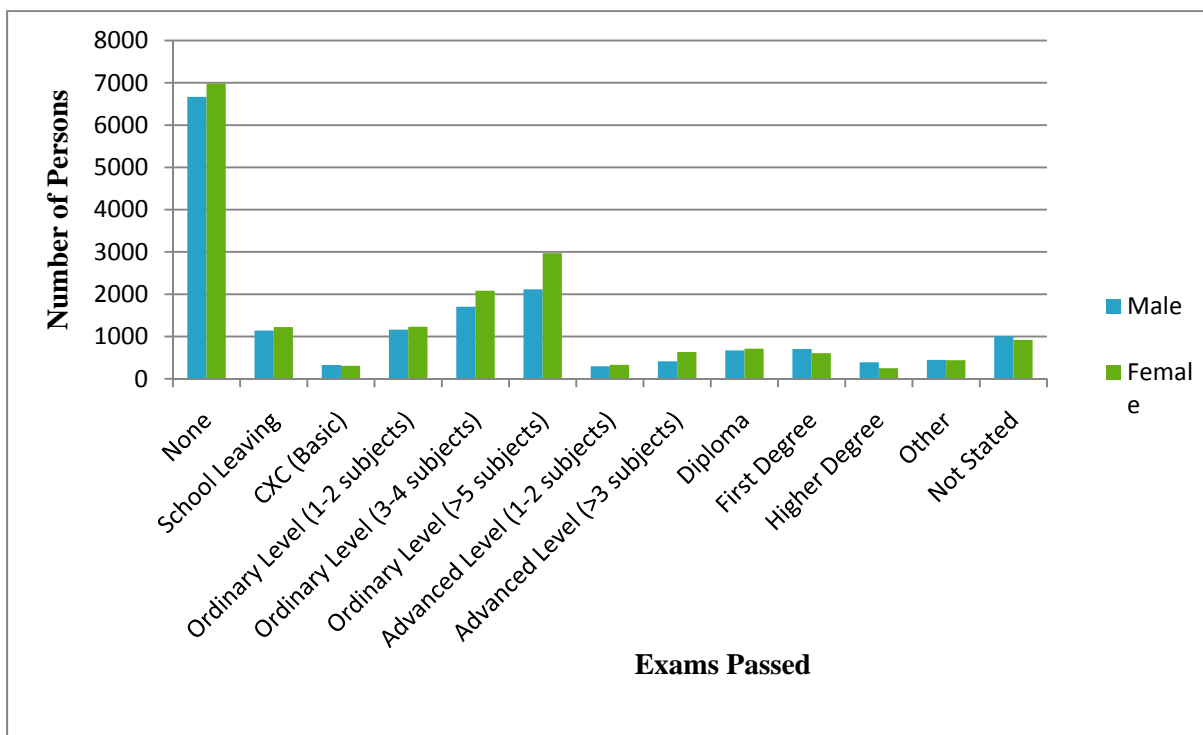


Figure 6-14 Highest Exam Level Passed (Central Statistical Office, 2002)



As depicted in these charts the majority of the population in the San Fernando City during the 2000 period only attained up to secondary level education and had achieved no academic certificates. In the 2010 social survey the majority of the persons attending school were at primary level and those that were enrolled in tertiary level institutions were primarily registered at the University of the West Indies (U.W.I.). This was still a major improvement compared to the 2000 Census results.

The 2000 Census, and social survey done by MFO in 2010 illustrates that the quality of life with respect to education was debatably low. A society with a high quality of life would have a greater number of persons attaining tertiary level education and achieving certificates for higher skills.

### 6.11.2 Housing

The tenancy arrangement and material used to build houses can be used to identify the quality of life of the residents. The social survey conducted in the project area investigated the type of housing material used in the areas assessed, Figure 6-15 represents these results. The majority of the residents built houses with both concrete and brick. This is a lower cost alternative in comparison to wood where only 3% of the residents constructed their houses with this material.

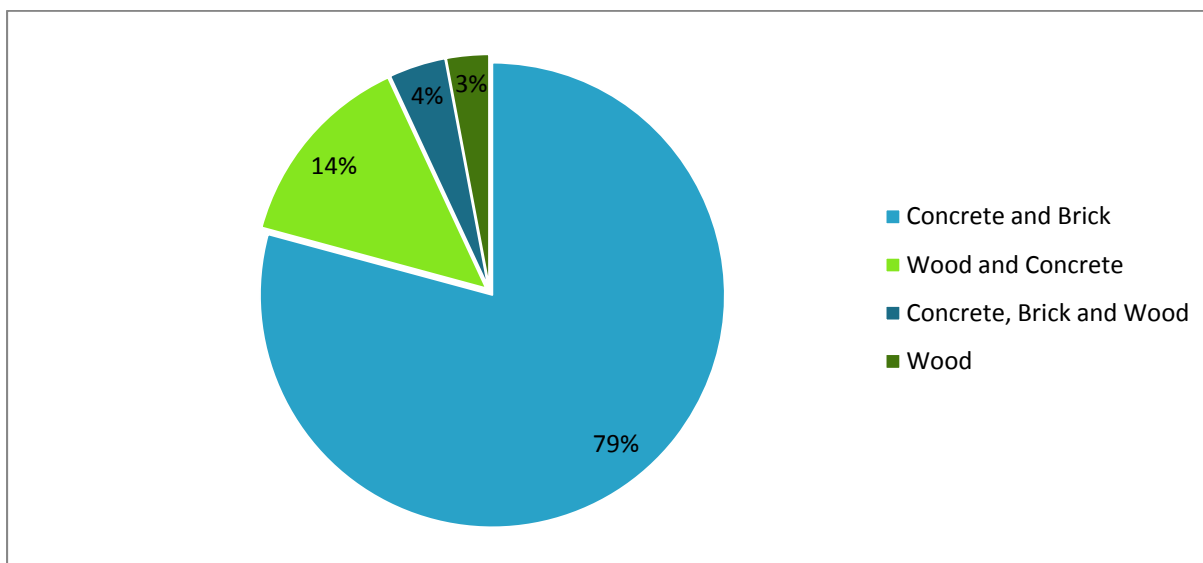


Figure 6-15 Housing Material in Surveyed Areas

### 6.11.3 Water Supply

The ability to supply a population with domestic water is not only an indicator of a good quality of life but it is also an obligation of the governing body of the society. The social survey conducted in partial fulfillment of the TOR for this EIA investigated the domestic source of water for the residents of the San Fernando Wastewater Catchment. Figure 6-16 shows the findings of these investigations and Figure 6-17 shows the findings in the year 2000. 86% of the residents in San Fernando had domestic water in 2000 and 98% of residents in the wastewater subcatchment areas were supplied with pipe borne water directly to their houses or yard. This is a positive indicator of a good quality life, in comparison to some communities having to obtain domestic water from untreated sources such as rivers, rainfall and lakes. The supply of treated water to 98% of the surveyed area therefore displays a high standard of life.

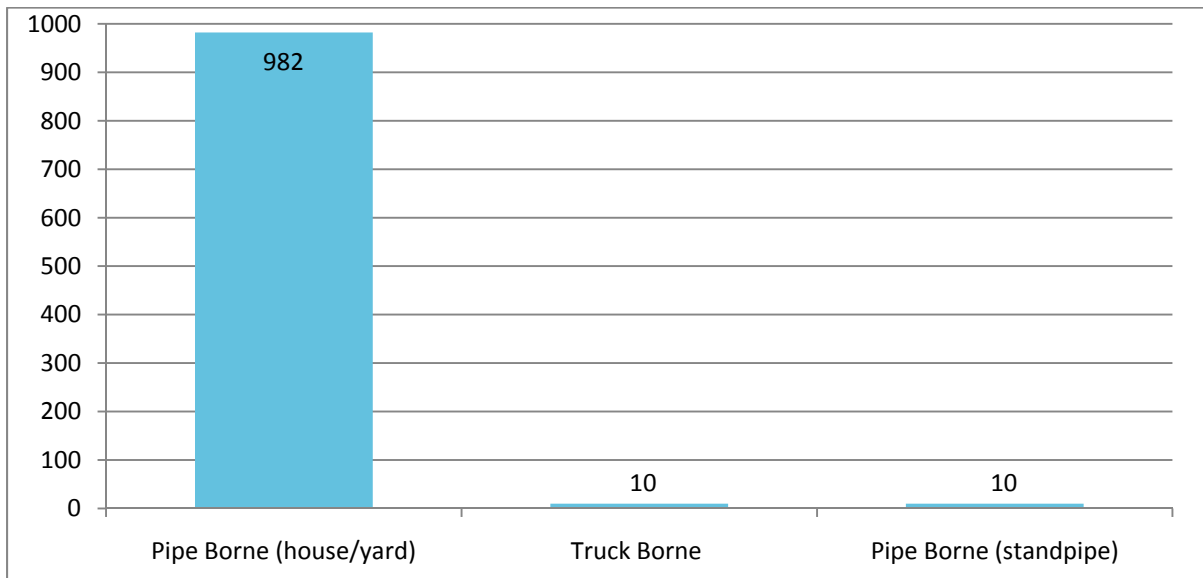


Figure 6-16 Domestic Water Supply in San Fernando Wastewater Catchment

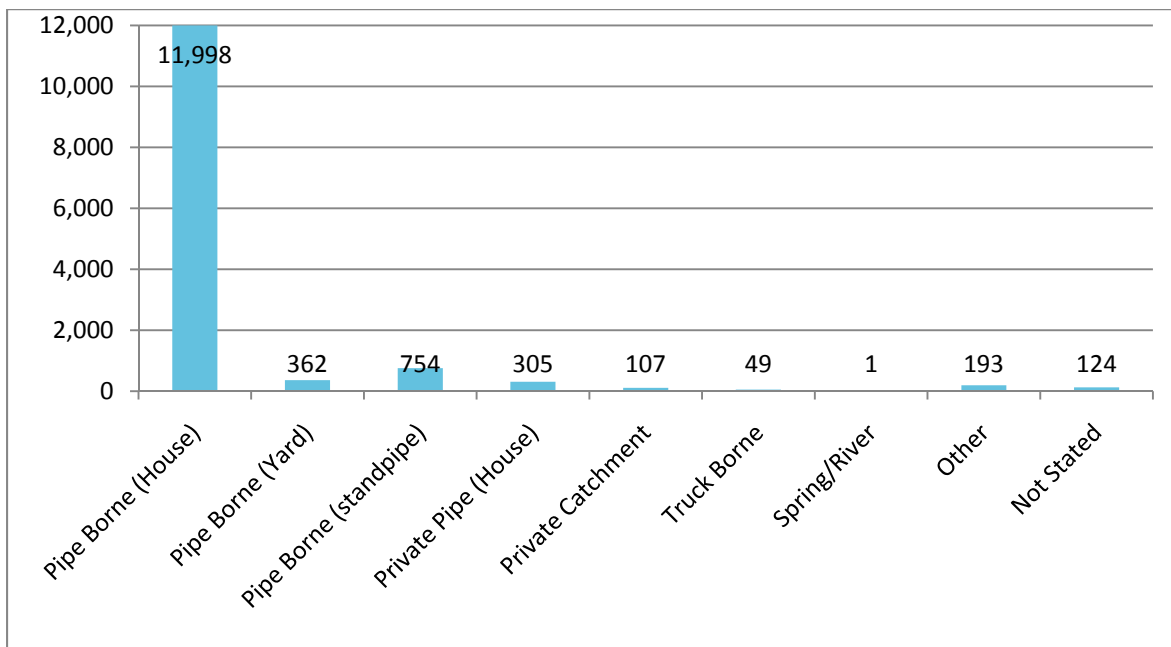
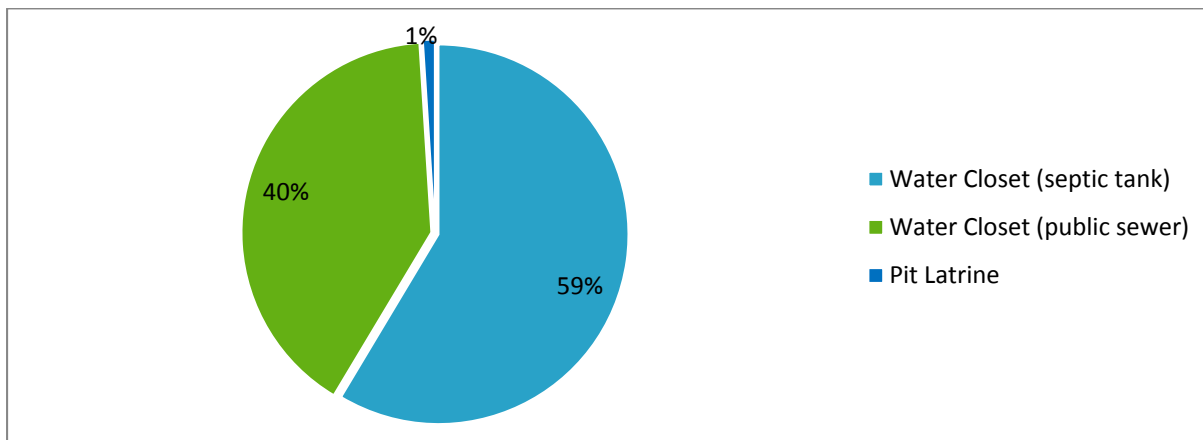


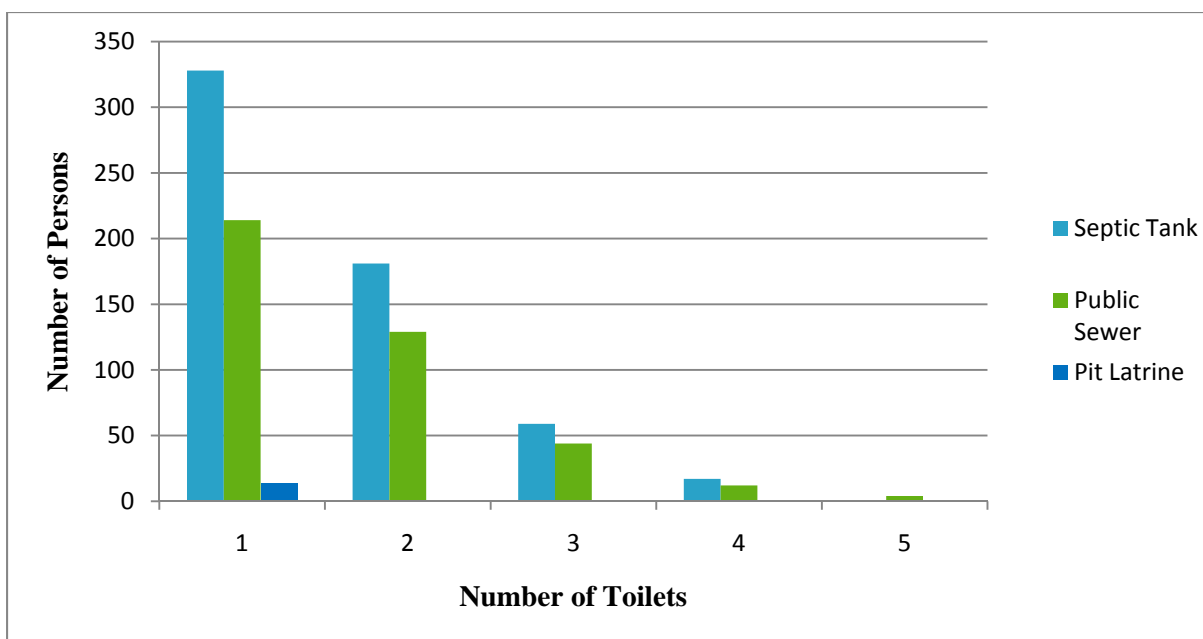
Figure 6-17 Domestic Water Supply in the City of San Fernando (Central Statistical Office, 2002)

#### 6.11.4 Sewer Collection

The toilet facilities and method by which the wastewater is disposed can be used to gauge the quality of life within a community. The social survey explored the type of toilet facilities in a household (Figure 6-18), the number of water closets in one dwelling and the type of disposal systems for the wastewater (Figure 6-19).



**Figure 6-18 Type of Facilities for Wastewater Disposal among Residents of the San Fernando Wastewater Catchment**



**Figure 6-19 Number of Toilets in Household and Type of Disposal Systems for Wastewater in Dwellings within the San Fernando Wastewater Catchment**

Figure 6-18 and Figure 6-19 depicts the outcomes of the social survey investigations into toilet facilities in the household. The 2000 Census also looked at toilet facilities in the San Fernando City, see Figure 6-20.

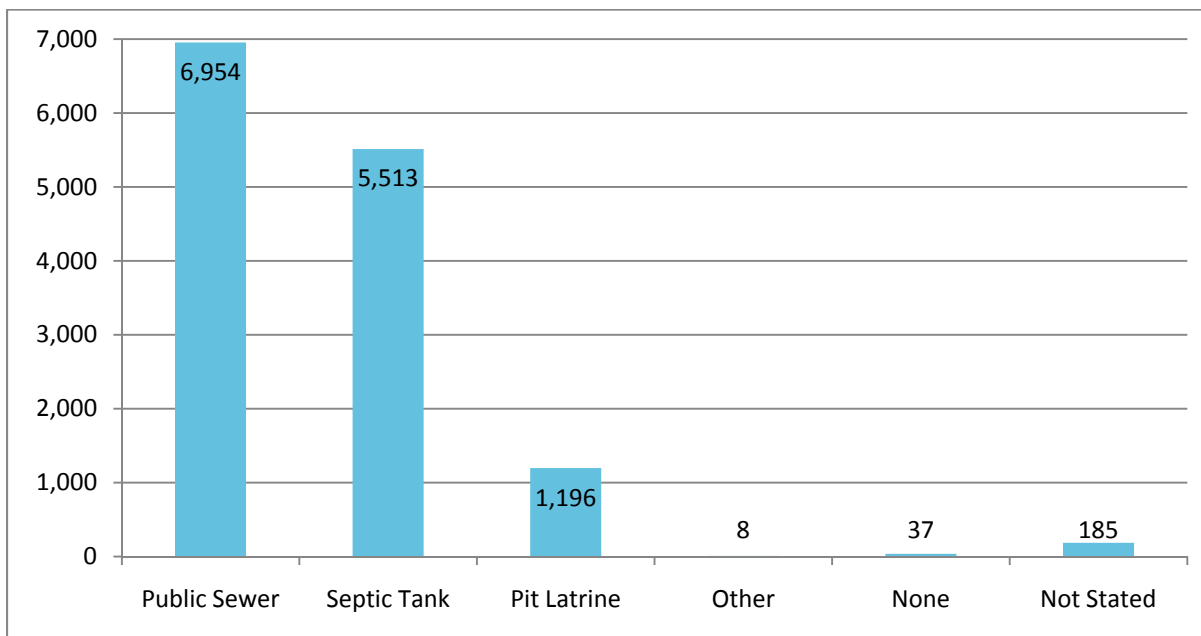


Figure 6-20 Type of Toilet Facilities in the City of San Fernando (Central Statistical Office, 2002)

The difference in survey results may be attributed to more residents interviewed for the 2000 Census in areas that are connected to the existing San Fernando wastewater collection system. The goal of the San Fernando Wastewater Project is to service all the residents so that wastewater can be disposed of efficiently and in an environmentally-friendly manner, thus improving the quality of life of the residents. This would eliminate septic tanks and pit latrines therefore eliminating major sources of pollution and enhancing the quality of human life from an environmental perspective.

### 6.11.5 Electricity Supply

Access to an efficient electricity supply demonstrates a high quality of life in a society. The social survey looked at electricity connection in the project area and the 2000 Census identified the different sources of electricity in the San Fernando City. The government is responsible for providing electricity for the population of Trinidad and Tobago; all households are supplied with electricity from T&TEC. Most of the residents acquire the power supply from this unit (Figure 6-21); all other sources are from an informal connection to a T&TEC electricity line. Figure 6-22 illustrates the results of the 2000 Census where most of the residents use electricity as their energy source. This has improved over the past ten years with the bulk of the populace currently utilizing electricity as the main power source.



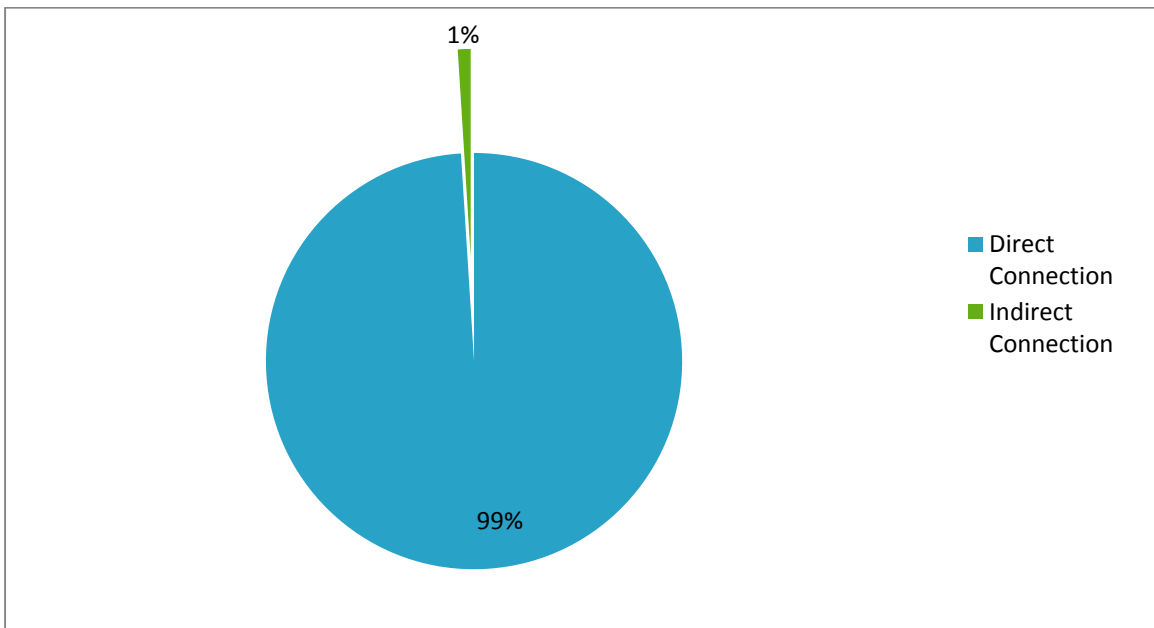


Figure 6-21 Type of Energy Source Connection in Project Area

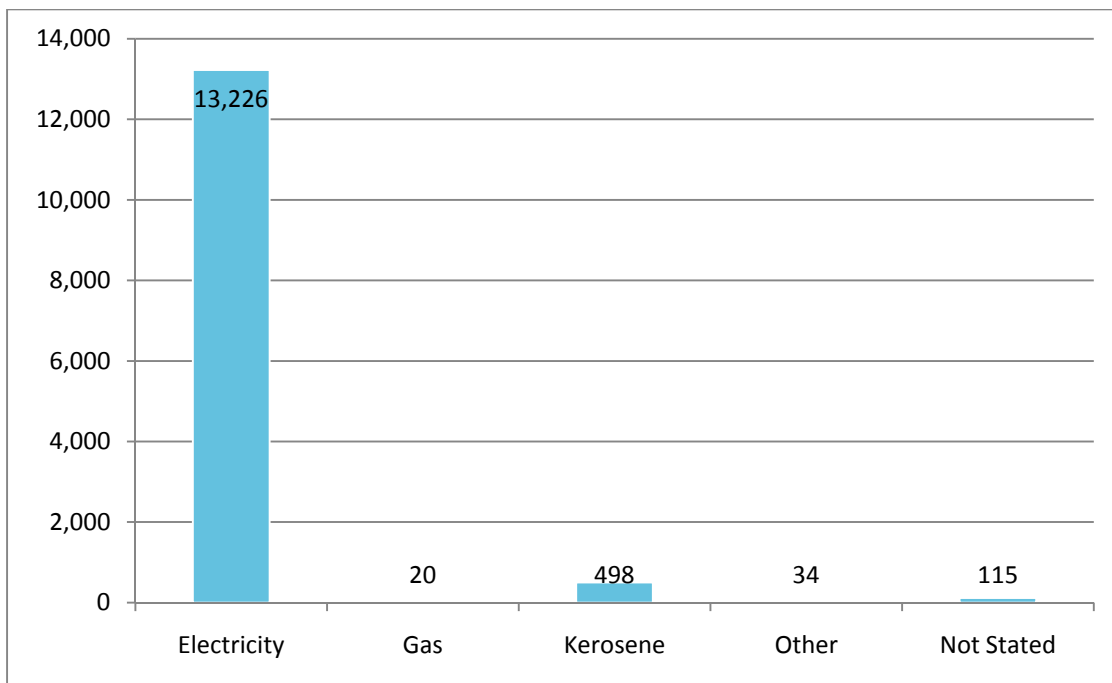


Figure 6-22 Household Energy Sources in San Fernando City (Central Statistical Office, 2002)

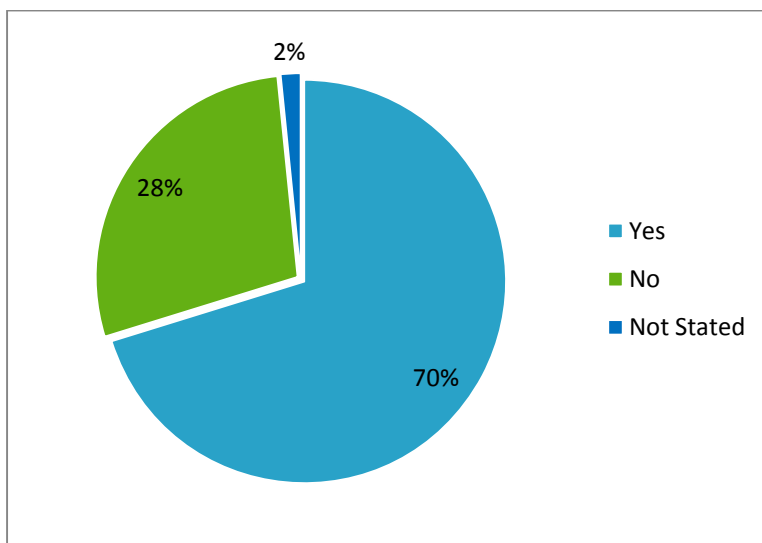


### 6.11.6 Telecommunications

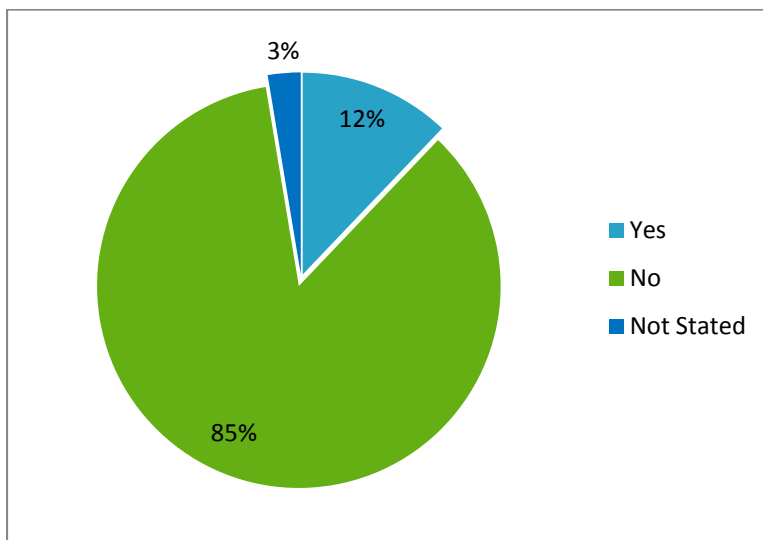
Telecommunications proves progression of technology in a society and is consequently a truthful indicator of the quality of life. In the San Fernando Wastewater Catchment area, there are two types of telecommunication services; telephones and the internet. The two main providers are:

- Telecommunication Services of Trinidad and Tobago (TSTT).
- Columbus Communications Trinidad Limited (FLOW).

These providers service most of the project area with TSTT being more established than FLOW because of its longer duration in Trinidad. FLOW has only been in existence for the past five years therefore infrastructure is still being installed to facilitate the access of services to the population of Trinidad and Tobago. The availability of telecommunication technology service to the residents of the San Fernando Wastewater Catchment denotes a high standard of living.



**Figure 6-23 Residents in the City of San Fernando with Telephones (Central Statistical Office, 2002)**



**Figure 6-24 Residents in the City of San Fernando with Internet (Central Statistical Office, 2002)**

Figure 6-23 and Figure 6-24 shows the results of the 2000 Census. Considerable improvement has been made over the last ten years in terms of population use of telecommunications; mainly the number of households with internet has increased.

### 6.11.7 Summary

In the 2009 door-to-door survey conducted by MFO, the socio-economic status was ranked as:

**Table 6-6 2009 Socio-Economic Status for San Fernando Project Area**

Socio-Economic Status Ranking	Percentile
Low	35
Middle	57
High	8

These results are based on the previously discussed socio-economic characteristics. As seen in Table 6-6, approximately 60% of the population ranks within the middle socio-economic group.

### 6.12 Social Services

Social services can be described as any institution that the Government of Trinidad and Tobago provides for the population. Social services may be free for citizens of the country or the cost may be partially subsidised by the Government. This section will be discussed based on the following themes:

- Health Care
- Transportation
- Education
- Protective Services



### 6.12.1 Health

The health care available to residents in the San Fernando Wastewater Project area includes clinics, health centres and a general hospital. Within the project area, there is one hospital, the San Fernando General Hospital, which services the residents of the entire portion of south Trinidad. This institution carries out a range of primary and secondary health care functions. The San Fernando Chest Clinic is another specialised health facility in the study area. There are a number of health centres in the San Fernando Wastewater Catchment (Table 6-7) which provide health care services to the surrounding communities.

**Table 6-7 Health Centers in Project Area**

Health Centre	Address
Debe	Wellington Road, Debe
Gasparillo	Church Street, Gasparillo
Pleasantville	Chaconia Avenue and Prince Albert Street, Pleasantville
La Romain	Zaida Lane, La Romain
Marabella	Market Street, Marabella
Ste. Madeline	Manahambre Road, Ste. Madeline

All the health institutions in the project area are managed by the South-West Regional Health Authority. Even though some of the organisations may not be located within the boundaries of the project area, such as the Debe Health Centre, the persons living in the study area are still serviced by these institutions.

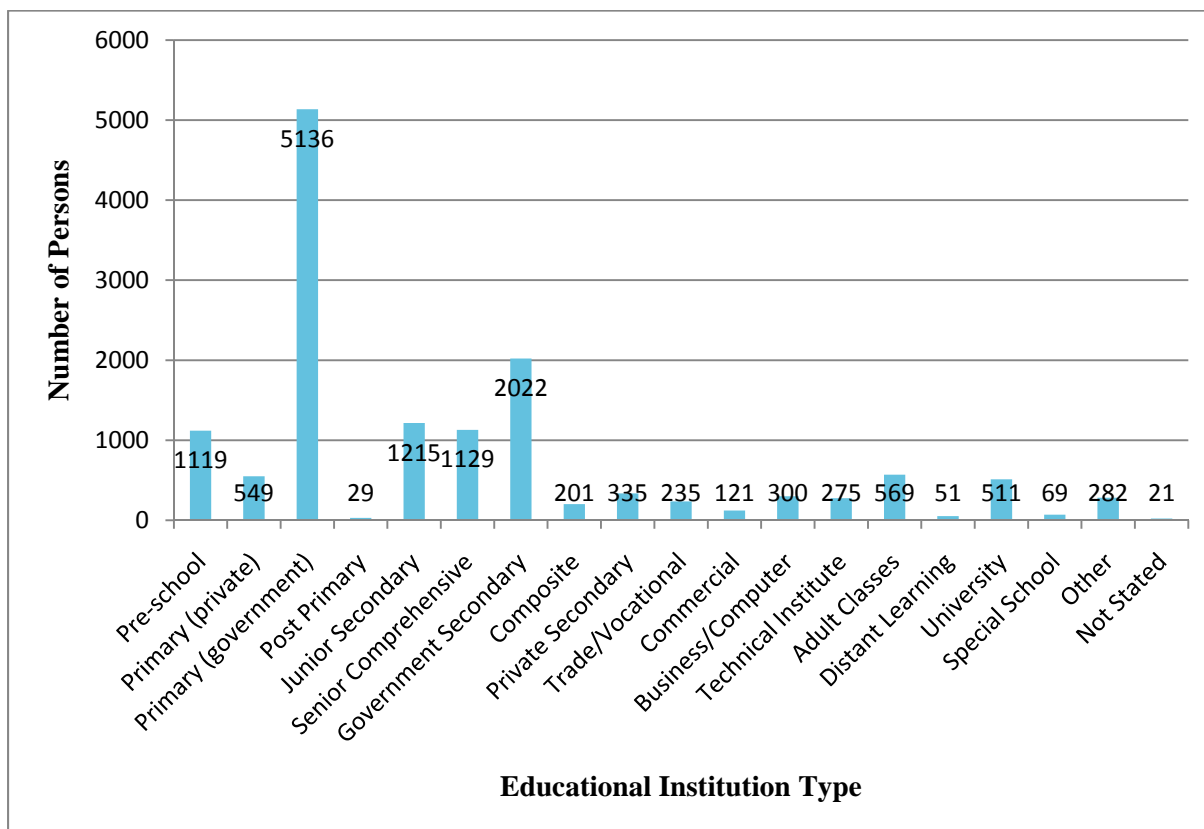
### 6.12.2 Transport

Transport in Trinidad and Tobago is considered a social service since the Government subsidises the cost of public transport throughout the country. The service is subsidised by the Government and is afforded to the public at an inexpensive cost. In the San Fernando Wastewater Project area, there are two main sources of public transport; buses and a water taxi service. The bus service is managed by the Public Transport Service Corporation (PTSC) and the main hub is located on the King's Wharf in the City of San Fernando. All the buses drop off and collect passengers at this point and transport to all areas in the country can be accessed from this hub.

The water taxi service is administered by the National Infrastructure Development Company (NIDCO) and comprises of boats that transport passengers from San Fernando to Port-of-Spain and return on a daily basis. The water taxi terminal is also located on the King's Wharf in San Fernando and operates only on working days.

### 6.12.3 Education

Education in the project area can be either government funded, government assisted or privately funded. The list of all the primary, secondary and tertiary level schools in the area is attached in **Appendix E.3**. The 2000 Census assessed the type of schools the residents were enrolled in; the findings are presented in Figure 6-25.



**Figure 6-25 Type of School Persons Enrolled in the City of San Fernando (Central Statistical Office, 2002)**

In the communities observed in the social survey undertaken for this project, the largest percentage of students attending primary school was enrolled in the San Fernando Boys R.C. Primary School located on Harris Promenade. The largest percentage of secondary students within the project area attended the Pleasantville Senior Comprehensive School on Collector Road, despite a fairly even distribution among the other secondary institutions. Among the tertiary level students, most of them were registered at U.W.I.

The Government also funds a number of social programmes to teach citizens different trade and vocational skills. This is organised by the Ministry of Community Development, Culture and Gender Affairs and are usually hosted in the community centres. Another educational institution under the Government within the project area is the Multi Sector Skills Training Programme (MUST) which seeks to equip interested nationals with different construction skills. This programme is useful to the construction phase of this project as graduates residing in the wastewater catchment could be targeted as potential employees for the San Fernando Wastewater Project.



#### 6.12.4 Police

The Police Force in the San Fernando Wastewater Catchment Area has branches throughout the project area. They are as follows:

- San Fernando Police Station
- Marabella Police Station
- Mon Repos Police Station
- Ste. Madeline Police Station
- Gasparillo Police Station
- Debe Police Station

The sphere of influence of each police station is usually determined by the location which an incident has taken place, similar to the operation of the municipal and supreme courts. Therefore persons residing in all different communities may be serviced by different police stations based on the location of the event. In the social survey done for this project, approximately 70% of residents were satisfied with the police service, in comparison to 29% who were not.

#### 6.12.5 Fire

There is only one fire station in the entire study area; the San Fernando Fire Station located on the San Fernando By-Pass. 90% of the population surveyed in 2010 were satisfied with the fire service available in the area while 8% were not. This institution is administered by the Ministry of National Security and emergency response is only given to areas within close proximity to the station. With respect to the study area, any emergency in the subcatchments will be addressed by the San Fernando Fire Station.

### 6.13 Social Survey

The social survey was conducted over a two week period in December 2009 by sub-consultant MFO, and a report of the findings was prepared and is attached in **Appendix E.6**. The objectives of the social survey were to:

- Describe the population demographics in the study area.
- Explain the socio-economic characteristics of the population.
- Identify the popularity of the project.
- Identify perceived attitudes and concerns associated with the project.

The following sections seek to explain the methodology used to undertake the social survey and the perceptions of the percentage of the population interviewed.

#### 6.13.1 Methodology

The sub-consultant MFO employed approximately twenty individuals to conduct field surveys within the subcatchments of the San Fernando Wastewater Project. The areas specifically targeted were analogous to the communities in which wastewater infrastructure was proposed under this project. The field investigators conducted exclusive interviews with the household head of the respective home. Queries were made on the following themes:



- Project awareness
- Perceived impact of the project
- Community structure
- Household characteristics
- Demographics of the household
- Socio-economic characteristics

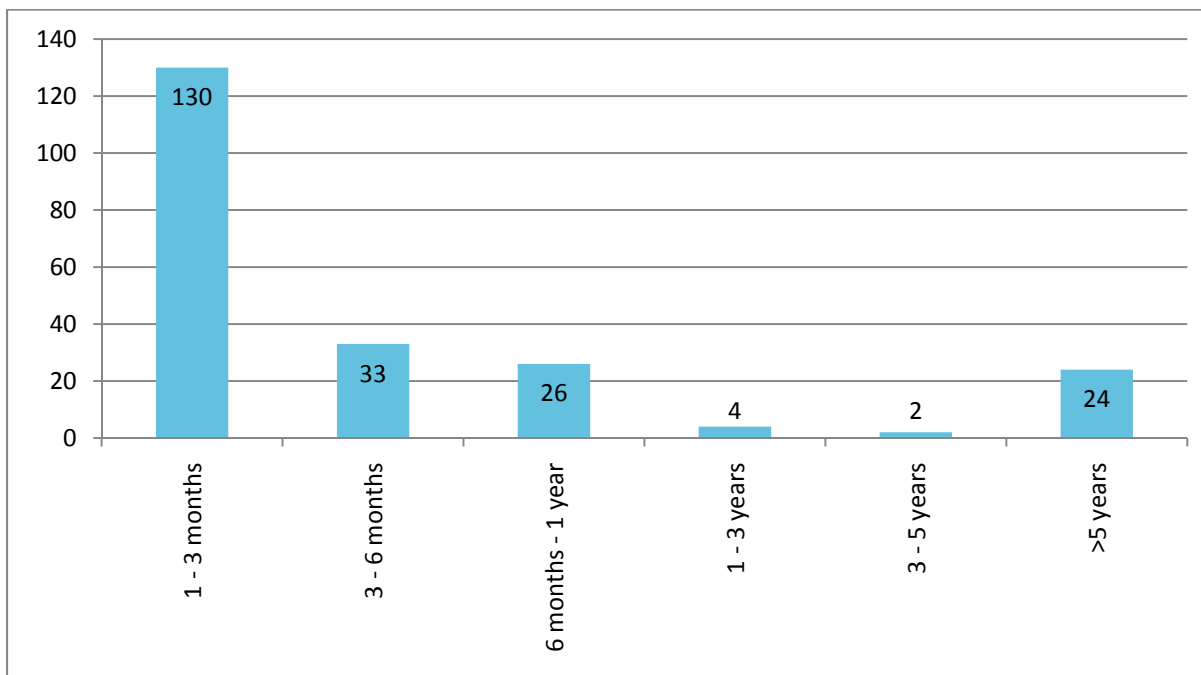
The findings of this survey are discussed in the following sections and the population demographic conclusions were examined in previous sections.

### 6.13.2 Socio-Economics

The survey investigated the socio-economic characteristics of the household by inquiring about specific items and belongings of the household. This variable along with the occupation and level of education was identified in the field investigation. These variables were ranked by MFO and the values are placed in **Appendix E.5**. A calculation was formulated to determine the socio-economic status of the project population. Typically, a household with a low economic status only had between 3 and 7 points. A middle economic standing would have been calculated between 8 and 17 points and a high economic status measured between 18 to 25 points. The majority of the persons, approximately 57% within the study area were within the middle socio-economic bracket while 35% of the respondents were of a low economic standing. The community with the highest percentage of a high economic population was Gulf View, where 32% of the residents had a high socio-economic status and 55% with a middle socio-economic rank.

### 6.13.3 Project Awareness

The social survey identified that only 22% of the assessed population were informed about the project. In this bracket, 74% of these individuals were made aware six months prior to the interview (Figure 6-26). The media was identified as the main informant of the project to the citizens. The first public consultation was held on January 26, 2010 therefore advertisement for this session would have increased the awareness of the proposed project in the study area.



**Figure 6-26 Length of Awareness of San Fernando Wastewater Project**

#### 6.13.4 Perceived Impacts and Concerns

The MFO researcher specifically enquired as to the perceived impact of the project on different characteristics of the individual's life, which incorporated personal impact, community impact and the impact of the project to various aspects of the environment. Generally 78% of the respondent perceived a positive impact of the San Fernando Wastewater Project. The majority of the residents (38%) identified the improvement of the environment, specifically health and cleanliness, as the major positive consequence of this plan. Whereas 51% of the respondents who perceived a negative impact indicated that the main basis of their perceived negative impact was the costs or that their WASA bill would increase.

The survey also assessed the benefit to the community of the San Fernando Wastewater Project and 85% of the population sensed a positive benefit where a cleaner and healthier environment would be produced as a result.

The respondents were asked to identify whether there would be a positive or negative impact on:

- Human Beings
- Ocean/Rivers/Drains
- Lands
- Animals/Plants
- Roads
- Air

Approximately 94% of the persons interviewed perceived a positive impact to human beings and the project was recognised as a benefit to the aquatic environment and air quality in the area. The main





justification of the positive impact to human beings is via cleanliness and health of the environment, while the negative impact to human beings was because of the economic aspects of the project.

The proportion of the population who were of the opinion that the San Fernando Wastewater Project would have a negative effect (22%) on the aquatic environment rationalised that it would be as a result of dumping and spillage of waste and chemicals that would pollute these habitats. A positive impact to air quality was recognised by 40% of the surveyed residents where a healthier, unpolluted atmosphere would be created as a result of this project. The respondents who sensed a negative effect on air quality attributed it to chemical use.

Half of the residents believed that there would be no impact to animals/plants in the area while the percentage that were of the opinion that there would be a positive effect accredited it to the animals and plants having access to a cleaner water supply. In comparison, the residents who believed the consequence would be harmful assumed this would be due to pollution of the water supply.

Similarly, approximately half of the respondents perceived no influence of the San Fernando Wastewater project to the land. The positive impact would be less erosion since drainage would be channelled while the negative impact identified would be land erosion according to the residents.

The environmental aspect which received the most negative ratings was the impact of the project to roads in the area where 45% of the respondents were of this opinion, their main reasoning being this was the destruction of the road network. In contrast those who envisioned a positive effect recognised that it would be as a result of a reduction of flooding on the road ways.

The developments that have occurred in the San Fernando Wastewater Project area were examined and the residents were questioned on whether the impact has been negative or positive, with the majority (76%) conveying a negative outcome of these developments. The major constructive consequence was more shopping and commercial activity while the chief negative impact was that the developments resulted in increase traffic in the areas.

Community nuisances were studied, with the three highest ranking being traffic (30%), odour (28%), and crime (26%). Untreated wastewater was a nuisance to 11% of those surveyed. Those communities that ranked 5% higher than the average were:

- La Romain
- Picton
- Duncan Village
- Green Acres
- Hermitage

All of these areas are presently not connected to the existing San Fernando Wastewater Collection System but are incorporated in the new wastewater design. It is suspected that those affected by odour are also being affected by untreated wastewater, and this is the source of some of the odours.

The assessment sought to identify an average range at which a resident will pay for a sewer service on a household basis. A significant fraction of the population indicated that they were willing to pay between TT\$1 to TT\$45 for the service. While one quarter of the residents felt that no increase should be charged for the service, Table 6-8 conveys a summary of the preferred price for sewer service.

**Table 6-8 Preferred Price for Sewer Service (Quarterly Rate)**

Price (TT\$)	Response (%)
\$1 - \$45	49
\$46 - \$65	8
\$66 - \$85	5
\$86 - \$104	9
\$105 or more	3
Nothing/Unwilling for Increase	25
Unsure	1

Interestingly, 40% of the respondents indicated that an irregular water supply was their main concern with bad roads (23%) and crime (18%) proceeding. Marabella and Picton were most affected by the irregular water supply with Picton being concerned most with bad roads. The area with the highest concern for crime in the community was San Fernando.

## 6.14 Road Traffic Survey

Construction of the collection system will occur on road right-of-ways, so determination of the impact to traffic will be important for the overall project impacts and mitigation. Understanding the existing traffic situation in the San Fernando area will provide baseline data in order to determine these impacts.

The principal routes for movement into the central parts of San Fernando from the northern and southern districts of the city are:

- Southern Main
- South Trunk Road
- San Fernando By-Pass

Traffic from central and northern Trinidad uses mainly the Solomon Hochoy Highway or the Old Southern Main Road to get to San Fernando. Surrounding communities located on the outskirts of San Fernando Wastewater Catchment area can be accessed via the Guaracara- Tabaquite Road, Naparima-Mayaro Road, Manahambre Road, and the M1 Tasker Road.

In San Fernando the main arterial routes are the San Fernando By-Pass, Connector Road, Lady Hailes Road, Tarouba Link Road, Naparima Mayaro Road, and Guaracara Tabaquite Road.

Construction of the collection system will occur along, or cross under all of these roads mentioned above.



Traffic counting was conducted March 23-25, 2010 at the locations noted in Figure 6-27. Monitoring consisted of three periods of 3-hour intervals during morning, noon and afternoon. These times were:

- 6am-9am
- 11am-2pm
- 3pm-6pm

Counting was conducted by one individual for each lane of traffic. The traffic count numbers were divided into vehicle types.

Roads that were selected for traffic counting were roads that are functioning as arterial, and where there is proposed collection system construction. The results from the counting are displayed in Table 6-9.

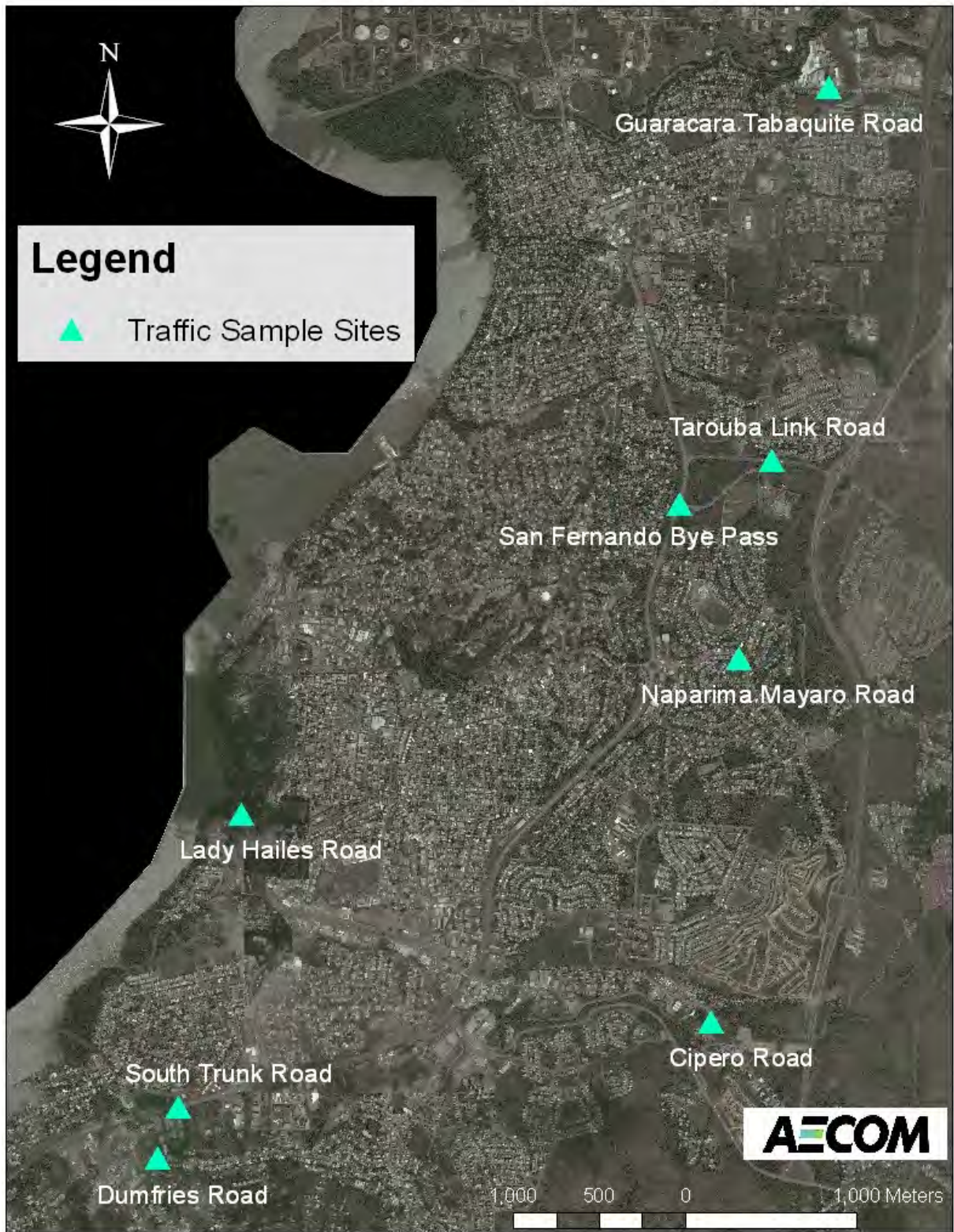


Figure 6-27 Traffic Sampling Locations



**Table 6-9 Traffic Counting Results, March 23-25, 2010**

Location		Time Period		Direction of Traffic	Vehicle Type					Count Summary		
Street Name	Total No. Lanes	Start	End		Motorcycle	Passenger Vehicle (Car, SUV, Recreational Truck)	Light Service Truck	Heavy Truck/ Construction Equipment	Bus/ Maxi Taxi	Total Count	Total Count Overall	Vehicles Per Minute
San Fernando By-Pass	4	6am	9am	N	4	4,279	200	70	92	4,645	25,121	47
				S	6	3,379	406	141	76	4,008		
		11am	2pm	N	7	3,938	289	54	34	4,322		
				S	8	2,948	333	175	53	3,517		
		3pm	6pm	N	10	4,341	196	59	63	4,669		
				S	8	3,537	220	115	80	3,960		
Guaracara Tabaquite Rd	2	6am	9am	E	1	1,139	24	72	10	1,246	9,420	17
				W	4	1,730	69	57	14	1,874		
		11am	2pm	E	3	1,374	92	58	10	1,537		
				W	2	1,241	102	67	7	1,419		
		3pm	6pm	E	1	1,691	65	23	10	1,790		
				W	-	1,456	64	20	14	1,554		
Naparima-Mayaro Rd	2	6am	9am	E	2	1,377	28	10	111	1,528	10,839	20
				W	-	1,531	53	16	80	1,680		
		11am	2pm	E	3	1,664	49	9	69	1,794		
				W	1	1,513	80	19	62	1,675		
		3pm	6pm	E	3	2,229	49	18	93	2,392		



**Table 6-9 Traffic Counting Results, March 23-25, 2010 (continued)**

Location		Time Period		Direction of Traffic	Vehicle Type					Count Summary		
Street Name	Total No. Lanes	Start	End		Motorcycle	Passenger Vehicle (Car, SUV, Recreational Truck)	Light Service Truck	Heavy Truck/ Construction Equipment	Bus/ Maxi Taxi	Total Count	Total Count Overall	Vehicles Per Minute
Naparima-Mayaro Road	2	3pm	6pm	W	3	1,634	58	13	62	1,770		
Lady Hailes Rd	2	6am	9am	N	-	2,166	700	73	1,140	4,079	14,115	26
				S	-	1,685	42	15	235	1,977		
		11am	2pm	N	4	1,510	219	36	188	1,957		
				S	2	950	73	13	91	1,129		
		3pm	6pm	N	4	2,365	707	69	935	4,080		
				S	3	706	66	8	110	893		
Dumfries Rd	2	6am	9am	N	1	762	34	11	4	812	5,170	10
				S	-	617	34	10	5	666		
		11am	2pm	N	-	621	34	23	4	682		
				S	-	869	29	23	6	927		
		3pm	6pm	N	-	594	29	15	2	640		
				S	2	1,354	38	32	17	1,443		
Cipero Rd	2	6am	9am	E	1	906	50	51	42	1,050	8,970	17
				W	3	1,781	37	17	67	1,905		
		11am	2pm	E	1	1,208	58	50	16	1,333		
				W	3	887	45	26	46	1,007		
		3pm	6pm	E	-	2,228	73	46	33	2,380		
				W	-	-	-	-	-	-		



**Table 6-9 Traffic Counting Results, March 23-25, 2010 (continued)**

Location		Time Period		Direction of Traffic	Motorcycle	Vehicle Type				Count Summary		
Street Name	Total No. Lanes	Start	End			Passenger Vehicle (Car, SUV, Recreational Truck)	Light Service Truck	Heavy Truck/ Construction Equipment	Bus/ Maxi Taxi	Total Count	Total Count Overall	Vehicles Per Minute
Cipero Road	2	3pm	6pm	W	2	1,178	64	22	29	1,295		
South Trunk Road				NE	1	3,205	136	86	65	3,493	16,528	31
				SW	1	2,147	123	145	110	2,526		
	4	11am 2pm		NE	-	2,226	180	159	46	2,611		
				SW	2	2,183	165	174	104	2,628		
		3pm	6pm	NE	1	2,075	169	156	44	2,445		
				SW	-	2,332	202	174	117	2,825		
Tarouba Link Rd	2	6am	9am	E	1	4,430	875	177	170	5,653	24,033	45
				W	1	3,370	78	42	47	3,538		
		11am	2pm	E	2	3,810	465	103	49	4,429		
				W	3	2,688	173	71	54	2,989		
		3pm	6pm	E	3	3,325	1,080	62	65	4,535		
				W	4	2,554	221	53	57	2,889		



Overall, the results of the traffic count study show high volumes of traffic on these roads within the project area, confirming that these roads are arterial for the San Fernando area.

The San Fernando By-Pass had the highest reported traffic volumes. When looking at the patterns throughout the day, there was more traffic during the morning and afternoon than the noon period. During the noon and afternoon periods, the traffic load in the north bound lanes was slightly higher than the south bound lanes.

On several roads, traffic patterns indicated that the highest volumes of traffic encountered are entering the core of the project area during the morning, and leaving in the afternoon. On the Naparima-Mayaro Road, and Ciperio Road, traffic driving west, entering the project area in the morning was slightly higher than the eastbound traffic. During the noon and afternoon periods, there was a higher volume of traffic leaving the project area. On Dumfries Road, in the morning there was more traffic driving north, towards the South Trunk Road, while the noon and afternoon sampling had higher traffic volumes entering the residential area. The South Trunk Road had higher numbers travelling northeast in the morning into San Fernando, and heading southwest, leaving San Fernando in the afternoon. The highest traffic volumes encountered were during the afternoon.

On the Guaracara-Tabaquite Road during the morning period, 60% of the traffic volumes were in the westbound lanes, entering Marabella and San Fernando. In the afternoon, the highest traffic volumes were encountered, with traffic volumes in the eastbound lanes accounting for 54% of the traffic volume. These results indicate that this road is used for commuters entering or leaving the project area for typical daytime jobs, or schooling. The higher difference in the morning may be attributed to the road network entering the project area. Another nearby entrance to the area is the Tarouba Link Road, however when entering from the Tarouba Link Road, the driver is unable to drive north into Marabella. This would increase the amount of traffic entering the project area by the Guaracara-Tabaquite Road.

The Tarouba Link Road had the second highest traffic volumes recorded, however this traffic is unbalanced, with 61% of the total volumes travelling east towards the Solomon Hochoy Highway. This unbalance may be due to the design of the road networks. Westbound traffic must turn south at the San Fernando By-Pass, making it difficult to enter Marabella. At the time of the road count, the westbound lane of the Tarouba Link road was also in a state of disrepair, and had been for awhile, so it may have been avoided by commuters. The San Fernando By-Pass is well designed to divert traffic east onto the Tarouba Link Road, making this an attractive option for drivers travelling towards the Solomon Hochoy Highway.

On Lady-Hailes Road, the highest numbers of maxi-taxis and buses were counted. This is expected as the San Fernando Bus Terminal is located beside the wharf area at the north end of Lady Hailes; the designated stand for these maxis is located adjacent to the Bus Terminal.





## 7. Key Stakeholder and Public Consultations

Public consultation is an integral part of the environmental assessment process. It provides the opportunity for interested stakeholders to receive information from the project design team and, in turn, allows the proponents to gain input about public concerns. Public consultation can also provide an opportunity to actively involve stakeholders in the early stages of a project which, in turn, delivers a sense of transparency in the assessment and planning process. Cooperation between the public, corporate and government sectors helps to determine and quantify the project impacts (both positive and negative), and to co-ordinate mitigation responses if needed.

For the San Fernando Wastewater project, liaison was made between AECOM, WASA and project key stakeholders in the form of a consultation meeting and separate introductory meetings for each agency. For this project, key stakeholders included utility agencies, government ministries, developers, and private businesses. Opportunities for public participation with residents of the San Fernando Wastewater Catchment Area were provided in the form of two open-house public consultations meetings as stipulated in the TOR of the CEC application. Door-to-door surveys were also conducted to provide feedback on the popularity of the project and to identify perceived attitudes and concerns associated with the project.

### 7.1 Requirements of CEC TOR

The TOR for obtaining a CEC for the San Fernando Wastewater Project was produced by the EMA for WASA to guide the development of an EIA and consequently this report. The TOR is attached in **Appendix A.1** and it gives details on the scope of the EIA.

The TOR identifies the need for key stakeholder and the public to “assist in the identification and mitigation of impacts while preventing environmentally unacceptable development, controversy, confrontation and delay.” It requires that the agencies most relevant to the project be identified and contacted to make their input to the project.

With respect to liaison with members of the public the TOR states that the consultation sessions should introduce and explain the project adequately as well as address all issues raised. Guidelines for conducting the consultations are also included; generally they should be held at a date, time and venue most convenient to the participants and should be advertised according to the standards given in the TOR. Any consultations held subsequent to the first session must address alternatives to the project and impacts that may have been identified.

For the San Fernando Wastewater project the following activities assisted in communication with the public and stakeholders:

- One meeting and presentation where all stakeholders were invited.
- Meetings with individual stakeholder groups.
- Two open house public consultation meetings.
- Door-to-door surveys.

This communication not only provided venues for AECOM and WASA to explain the project, it allowed for feedback from all persons on how the project will affect themselves and the organizations they are



representing. From these meetings, information was gathered that supplemented the design phase of the project. Negative impacts were attempted to be minimized to the extent possible. Door-to-door surveys are discussed in Section 6, and the meetings are listed in Table 7-1 below.

**Table 7-1 Schedule for Public Consultations and Stakeholder Meeting**

Meeting	Invitees	Venue	Date
Various Introductory Meetings with Key Stakeholders	Utilities, Ministers, Developers, Private Companies, Corporations	Various	Various
Key Stakeholder Meeting and Presentation	Industrial and Municipal Stakeholders; Utility Companies	WASA South Regional Office, St. James Street, San Fernando	September 30, 2009
Open House Public Consultation # 1	Public Citizens, Industrial and Municipal Stakeholders	San Fernando Central Secondary School (Modsec); Todd Street, Les Efforts West, San Fernando	January 26, 2010
Open House Public Consultation # 2	Public Citizens, Industrial and Municipal Stakeholders	Pleasantville Community Centre, Prince Albert Street, Pleasantville, San Fernando	April 13, 2010

The following sections are a description of the events listed above.

## 7.2 Introductory Meetings with Key Stakeholders

The San Fernando Wastewater Project was introduced to relevant stakeholders for the purpose of obtaining data pertinent to the treatment plant and collection system design. These agencies were also introduced to the project for the purpose of fulfilling the CEC TOR and facilitating coordination where proposed developments have the potential to conflict with the San Fernando Wastewater Project. These meetings were with individual groups and occurred mainly in the preliminary design stages of the project.

Table 7-2 lists the agencies that were contacted and the representatives present at the meetings with AECOM and in some cases WASA staff.

**Table 7-2 Introductory Meetings held with Relevant Agencies**

Agency	Representative(s)
Ministry of Works and Transport (MOWT)	Mr. Derek Bosland – Transport Division, Bridges Department
Gulf City Mall	Mr. Sanmook - Director
Petroleum Company of Trinidad and Tobago (Petrotrin)	Mr. Premchan Rambahrose – Penal Operations
Trinidad and Tobago Electricity Commission (T&TEC)	Mr. Farzard Nobbee – Utilization Department
Telecommunication Services of Trinidad and Tobago (TSTT)	Mr. Paul Gajar – Engineering Department
San Fernando City Corporation	Mr. Ramesh Sookdeo – City Engineer
Ministry of Planning, Housing and the Environment	Ms. Dixie Joseph – Land Settlement Agency (LSA) Ms. Sheryl-Anne Haynes – Director, TCPD Mrs. Shelley Sultanti-Maharaj – Assistant Co-ordinator, TCPD
Ministry of Local Government	Mr. Rodney Ramlogan – Regional Planning Unit Mr. Ewoud Heesterman – Interplan Consulting Group
PACE Construction Services Ltd	Mr. Francis- Site Engineer

### 7.3 Key Stakeholder Meeting

The Key Stakeholder meeting was held on September 30, 2009 to inform groups of the project, in order that cooperation could be obtained in gathering information relevant to the planning and design. The list of invitees was selected to include those groups who could be directly impacted by the proposed project. This list included utilities, developers, regional corporations, and government ministries. The full list of invitees and attendees is located in **Appendix F.1**. Information including utility as-built locations, future developments, and projects are critical to a successful wastewater project. This meeting also sought to determine the attitudes and expectations of stakeholders with respect to the project.

The presentation gave an overview of the project, and highlighted the importance of cooperation with stakeholders. A copy of this presentation is provided in **Appendix F.1**. A question and answer period followed as summarized in Table 7-3.

**Table 7-3 Questions and Answers from September 30, 2009 Meeting**

Concern Raised by Key Stakeholder	Answer by WASA and/or AECOM
Mr. Roger Parris (UDECOTT) - Concerns about individuals paying for connections to the new system. Most individuals will not pay to connect so the system will have low flow and the environmental problems will continue.	Ms. Denise Lee Sing Pereira (WASA) responded – WASA is planning to include service connections as a project cost.
Mr. Roger Parris (UDECOTT) - Concerns about as-built utility drawings and disrupting existing utilities with construction.	Mr. Jim Marx, and Mr. Matt McTaggart (AECOM) responded – AECOM has been trying for 6 months to obtain this information. It is disappointing that there are no utility representatives here today. AECOM continues to follow up.
Mr. Nigel Gopaul (CSO) - Curious about who was conducting social surveys.	Mr. Jim Marx (AECOM) responded – We have not finalized our sub-consultant yet. Ms. Kimlin Austin (WASA) responded – The social surveys are just a representative sample of the project area, it is not everyone that is being questioned.
Chris Mayhew (TriniTrain) – Rapid Rail needs to be aware of future developments so that all projects will be catered for, and there is no overlap.	Further discussion between AECOM and Mr. Mayhew after the meeting to exchange contact information.
(Ministry of Agriculture) – Project will have positive impact on fishing, and groundwater. Interested in uses of treated solid waste for agricultural application.	Sludge generated will be USEPA Regulation Class B solids, so there are options for agricultural application.

## 7.4 Public Consultations

These meetings were conducted to provide an opportunity for members of the public to learn more about the proposed project and to provide an opportunity for them to express their comments. In keeping with the TOR, two public consultations were held within the study area. From the interest of the public, comments received, and attendance numbers, it was determined that additional public consultations would not be necessary.

### 7.4.1 Public Consultation # 1

The first public consultation was held on Tuesday January 26<sup>th</sup> 2010 at San Fernando Central Secondary School (MODSEC) at 5:30 pm. Advertising was conducted through flyer distribution to businesses and the public in the project area, and advertising in the Daily Express® Newspaper on January 19<sup>th</sup>, 2010. Letter invitations were delivered to key stakeholders, members of government, utilities, and non-governmental organizations.



A formal PowerPoint presentation included:

- Introduction and purpose of the meeting.
- Project background.
- Overview of the design of Collection System and WWTP.
- EIA baseline sampling data conducted to date.
- Plan for completion of the EIA.

Time was allocated for answering questions, and receiving comments on the proposed project. Key questions and comments raised, and responses have been included in Table 7-4. Information on the public consultation including meeting notes, a copy of the presentation, flyer, a list of invitations, the PowerPoint presentation, and meeting notes are all located in **Appendix F.2**.

Thirty-four people attended the consultation, not including WASA staff, presenters or organizers.

**Table 7-4 Key Questions and Answers from January 26, 2010 Meeting**

Concern or Question Raised by Key Stakeholder	Answer by WASA and/or AECOM
Where does the water go after it is treated?	At the beginning of the project this was not in the scope of works, and discharge was to the Ciperio River. Once the project got underway, WASA asked that the possibility of treating the wastewater to reuse standards be examined as well. The design of the WWTP will now treat the wastewater to reuse standards through UV and filtration, in case WASA would like to use it for alternate uses.
As an officer of Public Health, we have issues all of the time with lift stations. They smell and it is a health hazard, especially the one at Pleasantville. When will these lift stations, especially this one, be phased out?	We know which lift station you are talking about. It is loud and it smells because it is so open. In the design, this lift station will be eliminated. Our design will be completed in July 2010, and from there WASA will need to secure funds for construction. We are unsure of how long this may take.
We have developments within your catchment area, Pleasantville, Retrench, Tarodale, etc. that all have their own wastewater treatment facilities. How will our HDC facilities be engineered into this new collection system?	AECOM has had meetings with ministers responsible for future development in the area, as well as determining the new housing developments which are sewered and have wastewater treatment plants. The HDC developments in the project area will be tied into the new collection system.
What provisions are there for Earthquakes?	All of the designs are conducted in accordance with the appropriate earthquake codes for Trinidad and Tobago.
Has the cost been considered? Or the least cost situation?	We are designing with cost in mind. The wastewater treatment plant is being built with high efficiency blowers and the plant hydraulics will be designed to minimize pumping, which will decrease the operation costs. Minimizing lift stations will decrease the operation costs because pumps will not be required and overall maintenance to the lift stations.

**Table 7-4 Key Questions and Answers from January 26, 2010 Meeting (continued)**

Concern or Question Raised by Key Stakeholder	Answer by WASA and/or AECOM
What tertiary treatment of effluent is occurring?	The tertiary treatment that will occur at the WWTP includes UV disinfection, and cloth filters.
Will collection system construction take into account material construction that will not break?	Yes, especially the areas where trenchless technology will be used. When the trenchless technology is used, the material required to withstand the jacking forces during installation means that the pipes have to be very strong. The likelihood of these pipes leaking is minimal.
Will more land space be required?	The wastewater treatment plant will be constructed at the existing San Fernando wastewater treatment plant, so additional land will not be required. A staging area during construction may be required, but land across the Ciperro River, where the Gulf View wastewater treatment plant is located could be used. This land is also owned by WASA, so no additional land would be required. During construction of the collection system, land easements will be required, but these are construction easements only.
Will soak-aways be tied into this new collection system?	Yes the houses with soak-aways will be connected to the new collection system. This will need to be studied on a case-by-case basis.
Will this project consider connections to existing systems in the project area, and repairs to existing systems?	Yes, all existing sewers within the project area will be integrated into the collection system. A CCTV program is currently underway to look for existing damaged pipes, and to replace those pipes under this project.

#### 7.4.2 Public Consultation # 2

The second public consultation was held on Tuesday April 13<sup>th</sup> 2010 at the Pleasantville Community Centre at 5:30 pm. Advertising was conducted through flyer distribution to businesses and the public in the project area, and advertising in the Daily Express Newspaper on April 7<sup>th</sup>, 2010. Letter invitations were delivered to key stakeholders, members of government, utilities, and non-governmental organizations. Anyone who attended Public Consultation #1 and left an email address was personally contacted through email.

A formal PowerPoint® presentation included:

- Detailed design of the collection system and WWTP.
- Updates in the design from Consultation #1.
- Results from the EIA baseline sampling.
- Impacts of the project.
- Mitigation measures during construction and operation phase.

Time was allocated for answering questions, and receiving comments on the proposed project. Key questions and comments raised, and responses have been included in Table 7-5. Information on the



public consultation including meeting notes, a copy of the presentation, flyer, a list of invitations, the PowerPoint presentation, and meeting notes are all located in **Appendix F.3**.

**Table 7-5 Key Questions and Answers from April 13, 2010 Meeting**

Concern or Question Raised by Key Stakeholder	Answer by WASA and/or AECOM
<p>What about the systems that do not function properly? Will these systems be fixed? Example; the Pleasantville Lift Station which emits bad odour and Orchid Garden Lift Station that discharges wastewater into the surrounding drainage system</p>	<p>The Pleasantville Lift Station would be eliminated and all existing infrastructure would be incorporated into the new San Fernando Wastewater Collection System Design.</p>
<p>How soon will the existing wastewater infrastructure be eliminated?</p>	<p>There is no quick fix for wastewater systems since it must be sustainable and therefore a long-term solution has to be employed. If a short-term resolution is used then the problem would recur. WASA acknowledges that their infrastructure has not kept pace with housing development in San Fernando. The SFWWTP would be functioning throughout construction of the Collection System. The San Fernando Catchment Area would be divided into phases for sewer installation so that priority areas would be serviced first.</p>
<p>Would co-ordination between water and sewer installation take place?</p>	<p>Co-ordination between agencies would take place before construction commences so that sewer and water pipes would be laid simultaneously.</p>
<p>The roadways are constantly disrupted and all utilities fall under the same Government Ministry so co-ordination should be better.</p>	<p>Concern will be taken into consideration.</p>
<p>Road repair is only done on the side of the road where the trench is located and the other side of the road becomes dilapidated because of heavy traffic flow. This needs to be taken into account during tender document preparation.</p>	<p>Traffic management plan would be included in tender documents to ensure this concern is addressed. Personnel from AECOM and WASA would supervise the work and ensure Contractor carries out according to the tender documents.</p>
<p>The detour roads that are utilised when traffic is diverted are not capable of traffic loads. The detour roads are damaged in the process and are never repaired.</p>	<p>This would be considered when formulating the traffic management plan for the tender documents.</p>

**Table 7-5 Key Questions and Answers from April 13, 2010 Meeting (continued)**

Concern or Question Raised by Key Stakeholder	Answer by WASA and/or AECOM
Are the sewers routed according to low points?	Yes, some of the sewer routes are proposed along the rivers and in certain areas trenchless technology would be used.
Resident lives alongside a major drain in Phillipine/Duncan Village which is in need of repair and inquired if this drain would be fixed when sewers are laid.	The project does not entail repairing all drains in the project area but if the sewer is proposed in the area when it is installed the drain would be fixed in the process.
Who will give final approval when determining priority of subcatchments to be seweraged? Would it be Consultant or Ministerial Committee?	AECOM is recommending which areas would benefit most from sewer installation. The Client, WASA would make the final decision.
Will the new San Fernando WWTP be operational before the Collection System?	AECOM plans to tender the new WWTP and Collection System simultaneously. Therefore a trunk sewer can be laid to connect areas that are already seweraged to the new WWTP. These areas would have the most beneficial cost for construction.
Is the new WWTP designed to accommodate existing development or proposed development?	The new San Fernando WWTP will encompass new development and projected population. Satellite photos were used to determine and project the increase in population. Flows projected to 2035 and based on a population growth where all unused land in the San Fernando area would be developed.

The questions and concerns raised in the second public consultation were addressed during the meeting, however, any further clarification needed should be provided in this report. After the second public consultation one of the residents emailed further questions about the San Fernando Wastewater Project. These questions and responses are included in **Appendix F.3**.

## 7.5 Conclusion

The perceived notions and attitudes of the public towards the project are generally positive. The residents and stakeholders realise that the project would be beneficial to the environment and their main concerns were about:

- Effluent and treatment
- Malfunctioning systems
- Areas to be seweraged
- Project cost
- Project schedule
- Roads





The questions of the persons attending the liaison meetings were addressed in the sessions; however, the report seeks to address any issues that may not have been clarified. The social survey conducted to fulfil the TOR for the CEC application of the San Fernando Wastewater Project also sought to identify the perceptions and attitudes of the residents. The findings of this evaluation were discussed in Section 6 and are used in addition to the public consultations to determine the impact of this project on the lives of the residents and business population within the project area.



## 8. Impact Analysis and Mitigation Measures

The EIA process provides a formalized procedure for obtaining project specific, local environment, and social information to evaluate the anticipated or probable environmental consequences of conducting a specific project activity.

This Section presents the methodology for the identification of project-environment interactions, a review of predicted project impacts, and an evaluation of these impacts. The objective of this analysis is the identification of significant aspects and impacts which will require appropriate mitigation and/or future monitoring.

### 8.1 Methodology

#### 8.1.1 Impacts Assessment

An impact is any change in an environmental parameter both social and physical due to a particular activity or event. Evaluation of environmental and social impacts involves the following steps:

- Description of project activities
- Description of environmental attributes
- Identification of project-environment interactions
- Prediction of environmental effects
- Description of environmental effects

The project activities were described in Section 3 of this EIA Report including decommissioning activities of the existing wastewater infrastructure. The environmental and social attributes that may be affected as a result of this project were discussed in Sections 5 and 6 respectively. Potential environmental impacts were identified by superimposing project elements onto existing natural conditions. An underlying assumption is that the San Fernando Wastewater Project will be constructed with due care for safety and environmental matters, using current and reasonable engineering practices.

The impacts were assessed based on the nature of the effect, magnitude, spatial extent, duration, project phase and the degree of reversibility. Various terms have been used to identify and describe the potential impacts assessed. Table 8-1 provides an explanation of these terms.



**Table 8-1 Explanation of Terms Used in Impact Assessment**

<b>Project Phase:</b>	Refers to the phase of the project as construction, operation or decommissioning of the existing wastewater facilities.				
<b>Potential Impact:</b>	Classification of the type of impacts anticipated during a specific project phase. This includes: soil quality, air quality, water quality, flora and fauna populations, transport and social environment.				
<b>Magnitude of Impact:</b>	<p>Refers to the estimated percentage of population or resource that may be affected by activities associated with the construction, operation and decommissioning of the proposed WWTP and collection system. Where possible and practical, the population or resource base has been defined in quantitative or ordinal terms (e.g., hectares of soil types, units of habitat). Impact magnitude has been classified as less than (&lt;) 1%, 1 to 10%, or greater than (&gt;) 10% of the population, or resource base.</p> <p>Where the magnitude of an impact has been defined as virtually immeasurable and represents a non-significant change from background in the population or resource, the impact is considered negligible. An exception to this is in terms of potential human health impacts where for example, deaths due to waterborne disease amounting to 1% of the population would still be considered major.</p>				
<b>Direction of Impact:</b>	Refers to whether an impact to a population or a resource is considered to have a positive, negative or neutral effect.				
<b>Duration of Impact:</b>	Refers to the time it takes a population or resource to recover from the impact. If quantitative information was lacking, duration was identified as short-term (<1 year), medium term (1 to 10 years) and long term (>10 years).				
<b>Frequency of Impact:</b>	Refers to the number of times an activity occurs over the project phase, and is identified as once, rare, intermittent, or continuous.				
<b>Scope of Impact:</b>	Refers to the geographical area potentially affected by the impact and was rated as local, regional, or national. Where possible, quantitative estimates of the resource affected by the impact were provided.				
<b>Degree of Reversibility:</b>	Refers to the extent an adverse impact is reversible or irreversible over a 10-year period.				
<b>Residual Impact:</b>	A subjective estimate of the residual impact remaining after employing mitigation measures in reducing the magnitude and/or the duration of the identified impacts on the environment.				
<b>Magnitude of Impact</b>	<b>Direction of Impact</b>	<b>Duration of Impact</b>	<b>Frequency of Impact</b>	<b>Scope of Impact</b>	<b>Degree of Reversibility of Impact</b>
Negligible (immeasurable)	Positive	Short term (< 1 year)	Once	Local	Reversible
Minor (<1%)	Negative	Medium (1 to 10 years)	Rare	Regional	Irreversible
Moderate (1 to 10%)	Neutral	Long term (>10 years)	Intermittent	National	
Major (>10%)			Continuous		



The evaluation of impacts should address, at a minimum, the following components which are anticipated to be affected by the proposed construction and operating activities:

- Air quality
- Water quality
- Soil quality
- Flora and Fauna
- Human Environment (social, health and economic impacts)

The potential impacts on specific environmental parameters should be described in terms of relative or absolute significance, where possible. Impacts are defined as negligible, minor, moderate or major according to the terms in Table 8-1.

### 8.1.2 Mitigation Measures

Mitigation measures are used to avoid, limit and control the impacts to the biophysical and social environment. Mitigation measures not already included in the design of the San Fernando Wastewater project will be provided to contractors and operations personnel for implementation during the construction and operational phases of the project. The mitigation measures proposed will be used as an alternative to enhance the biophysical and social benefits of the project. The residual impact remaining after implementation of mitigation measures will also be determined as part of the EIA. Where impacts are determined to be negligible, no mitigation is required.

All project impacts and mitigations are discussed in Sections 8.3 through 8.10 with a summary in Section 8.11. Table 8-4 displays all project impacts and mitigation measures.

## 8.2 Project- Environment Interactions

Identifying the interactions between the project and the environment leads to the determination of the potential environmental effects on the project. Section 3 presents a description of the project, and from this description the interactions with the environment can be determined.

An environmental interaction is any element of a facility's activities, products, operations or services which can or will interact with the environment. These interactions and their effects may be continuous in nature, occur periodically, or may be associated with specific events, such as emergencies. Some interactions may be beneficial, such as a reduction in odours; however the primary objective of this EIA study is to identify and minimize the negative impacts.

Based on an understanding of the proposed project and the sequence of project activities, the following project-environment interactions were determined (Table 8-2). This list is not comprehensive but presents the key likely impacts occurring in the construction, operation, and decommissioning stages of the project.



**Table 8-2 Project-Environment Interaction with Affected Environment**

Project-Environment Interaction	Affected Environment					
	Water	Air	Soil	Biological	Traffic	Other Social
Storage/staging and stockpiling of materials, and chemicals <sup>C,O</sup>	x	x	x		x	x
Obtain easements <sup>C</sup>						x
Use of labour <sup>C,O</sup>						x
Transportation to and from site (personnel, equipment, machinery) <sup>C,O</sup>		x			x	
Use of construction equipment and machinery <sup>C</sup>		x	x	x		x
Use of lighting <sup>C,O</sup>				x		x
Storage and disposal of construction debris and waste <sup>C</sup>	x				x	x
Use of chemicals, coatings and paint <sup>C,O</sup>		x				
Ground excavation, vegetation clearing, ground compaction, trenching, piling <sup>C</sup>	x	x	x	x	x	
Alteration of grade and drainage patterns <sup>C</sup>	x		x			
Construction of WWTP <sup>C</sup>	x	x	x			
Construction Collection System Sewer <sup>C</sup>	x	x	x		x	
Water supply management <sup>O</sup>	x					
Effluent release to catchments <sup>C,O</sup>	x			x		x
WWTP Equipment operation <sup>O</sup>		x				
Sludge Management <sup>C,O</sup>		x	x		x	
Odour Management <sup>C,O</sup>		x				

Note: C = construction phase; O = operation phase



## 8.3 Air Quality Impacts and Mitigation

### 8.3.1 Construction Phase

During the construction phase of the project, as described in Section 3, a new WWTP and eight lift stations would be constructed, the existing facilities would be decommissioned and the sewer pipes would be installed. The impact to air quality is addressed in terms of exhaust emissions, generation of airborne particles and dust and release of odours. The mitigation measures intended are also identified in this section based on the characteristics of the impacts.

#### 8.3.1.1 Exhaust Emissions

There exists potential for negative air quality impacts due to emissions from construction equipment operating on-site during construction and decommissioning activities, as well as vehicle transportation to the site. It is estimated there will be 50 vehicles or less at any one time at the WWTP site during the construction process, including worker vehicles and heavy equipment. As shown in Section 5.2.1, the wind is generally north easterly, which will likely provide some mitigation of exhaust emission effects as exhaust will be dispersed into undeveloped areas, and over the Gulf of Paria.

Unmitigated vehicle and equipment exhaust emissions are anticipated to result in a minor decrease in air quality on the site and a negligible decrease in air quality off the site.

Mitigation measures could include:

- Encouraging all workers not to idle vehicles.
- Carpool to site.
- Perform vehicle inspections regularly and maintain equipment.

Post mitigation, the residual impact will be minor on site, and negligible off site. These negative impacts will be of medium term duration, potentially occurring on a continuous basis during working hours of the construction period on a local scale and are considered reversible.

#### 8.3.1.2 Airborne Particles and Dust

Potential impacts to air quality may be caused due to generation of airborne particles and dust during construction and decommissioning activities of the WWTP and lift stations from:

- Vehicle movement along site roads.
- Earthworks.
- Storage and stockpiling of materials.
- Demolition activities, inclusive of de-sludging the existing drying beds.

Dust and airborne particles will increase when vehicles move along the unpaved site roads, especially during the dry seasons. During construction of the collection system, the earthworks undertaken would generate airborne particles and dust especially from excavation and the demolition of decommissioned facilities. Dust has the potential to negatively impact air quality with subsequent potential impacts to human health and flora (dust deposition).



Unmitigated impacts to air quality due to airborne particulates and dust will be negative and minor in magnitude.

Mitigation measures could include:

- Dust suppression activities such as watering roadways and exposed ground.
- Minimizing the amount of disturbed area.
- Backfill exposed construction site as soon as possible.
- Limit height of stockpiles on topsoil and to 2m height.

Post Mitigation, the residual impact will be minor on site and negligible off site. These negative impacts will be of medium term duration occurring intermittently during the construction period on a local scale. Impacts due to airborne dust and particles are considered reversible.

### 8.3.1.3 Odours

During the construction period, there will be potential for odour generation due to:

- Use of chemicals such as paint, asphalt, adhesives and solvents.
- Removal of sludge from existing drying beds and the area west of the drying beds.
- Use of a new septage receiving station during construction.

Chemicals used during construction may emit odours especially in areas that are sheltered or not well-ventilated. The odour emanated can have a direct impact to human health if used in enclosed spaces.

At the existing San Fernando WWTP, the closest residents to site to the sludge drying beds, and the area west of the sludge drying beds are located approximately 55 m north-west of the site to be excavated. As shown in Section 5.2.1, the wind direction is generally north easterly, causing the exhaust to disperse into undeveloped areas south west of the Site, and over the Gulf of Paria. There is also an existing drain with trees and underbrush on either side of the drain between the drying beds and these residences. The trees and underbrush may provide some dispersion or masking of odours. Although some odour impacts to the nearest residences may occur during the de-sludging process, the excavation activity will be limited to approximately 2 weeks or less during the construction phase, therefore limiting the extent of potential impacts.

The new septage receiving station will be built on the south-eastern end of the WWTP site, close to the Riverside Drive entrance, to maintain accessibility for septage trucks to continue to dispose of the septage throughout the construction phase. The closest residents to the proposed WWTP are located directly east of the WWTP site, approximately 25 m away from the new septage receiving station location.

The unmitigated impacts from these activities will be minor to moderate in magnitude, on a local scale.

Mitigation measures proposed include:

- Use of chemicals
  - Limit use to a well-ventilated area.



- Ensure OSHA rules are followed.
- Provide masks for staff working with chemicals that release a strong odour.
- Sludge Drying Bed excavation:
  - Conduct excavation when wind is directed predominantly to the southwest.
  - Utilize dust suppression activities.
- Septage Receiving Station:
  - Activated carbon filter odour suppression equipment, (Section 3.9.2).
  - Physical barrier wall to be built between septage receiving facility and residents directly east.
  - Complete decommissioning activities promptly to limit the odour generated that can affect employees and residents.

Post-mitigation, the impact will be negligible, during the construction period, on a local scale. Frequency will range from intermittent for the chemicals and sludge excavation to continuous for the septage receiving station.

### 8.3.2 Operation Phase

The operation phase of the San Fernando Wastewater Project as addressed in this section deals with mainly the proposed WWTP, proposed lift stations and new sewer pipes installed as part of the project. The effects of these activities on air quality are described below.

#### 8.3.2.1 Exhaust Emissions

During the operational phase, there will be traffic accessing the WWTP site for delivery of materials and chemicals, biosolids removal, septage receiving, and worker vehicle traffic. These proposed traffic volumes represent an overall reduction compared to the current operation of the WWTP as seen in Table 8-3.

**Table 8-3 Weekly Anticipated Traffic at San Fernando WWTP Site During Operation**

Site Traffic	Current WWTP	New WWTP
Material delivery	1	1
Biosolids removal	0	25
Septage Receiving	68	54
Worker traffic	137	70
<b>Total</b>	<b>206</b>	<b>150</b>

This decrease to traffic results in a relative positive impact to the exhaust emission generated. No mitigation measures are required.





### 8.3.2.2 Airborne Particles and Dust

The current operation of the WWTP uses sludge drying beds that generate airborne particles and dust on an intermittent basis during clean-out activities. With the proposed design, there is potential for the generation of airborne particulates and dust during the operational phase of the project due to:

- Traffic movement on the WWTP site.
- Water aerosol generation from the bioreactors.

This would result in a negative minor impact.

Mitigation measures proposed include:

- Replacing the sludge drying beds with DAF thickening, aerobic digestion, and a belt filter press to dewater the sludge (See Section 3 for a complete description). DAF thickening and aerobic digestion may produce water aerosol, however, tank freeboard will contain these aerosols.
- Paving the roads of the WWTP site.
- The design of the bioreactor was chosen as fine bubble aeration which produces fewer aerosols and is quieter than mechanical surface aeration. The design has also incorporated additional tank freeboards to contain the aerosols.

With the incorporation of these mitigation measures in the design the post-mitigation impact is expected to be negligible and local in scale over the long term (for the life of the WWTP facility).

### 8.3.2.3 Odours

Treatment at the existing WWTP generates odours, mainly due to:

- Septage Receiving Station – This is an open-air process that uses aeration. Significant odours are generated at this step. Screenings are piled beside the station and intermittently buried or trucked off-site.
- Grit Removal Chambers – The screenings and grit from this process are piled beside the chambers on the ground, and intermittently buried or trucked off site.
- Trickling filter ponding – Due to the maintenance issues and age of this process step, the two trickling filters, located on the south side of the site, 40m away from the closest resident, generate odours.
- Anaerobic digesters – Anaerobic digestion causes the release of hydrogen sulphide, a gas associated with a “rotten egg” smell. These two digesters, located 15 m away from the property line of residents, are not fully operational, so additional odours are being generated.

When the above factors combine, there are reportedly significant odours that are generated at the current WWTP.

The proposed WWTP design could have the potential for operational odour generation due to:

- Storage of screenings, grit and biosolids prior to disposal.
- Collection of septage on the site.



During the screening and grit removal stages of the proposed wastewater treatment process, compacted screenings, and dewatered grit will be discharged to a dumpster for storage before being hauled off-site for disposal. This has the potential to result in the release of odours in the dumpster area. The odours would be expected to exist on a local scale in the area immediately surrounding the dumpster area.

The new septage receiving station will be built on the south-eastern end of the WWTP site, close to the Riverside Drive entrance, to maintain accessibility for septage trucks to continue to dispose of the septage throughout the construction phase. The closest residents are located directly east of the WWTP site, approximately 25 m away from the proposed septage receiving station. This could result in a negative odour which, if un-mitigated, could extend to the residents' home.

Mitigation measures to address odour control have been incorporated into the design of the proposed WWTP to address these impacts, as well as the current issues at the existing San Fernando WWTP. These include:

- Storage of screenings and grit in closed containers (dumpsters) instead of on the ground.
- Ensuring all waste is hauled off-site on a scheduled and timely basis.
- Construction of a contained septage receiving station, with odour control.
- Maintaining odour suppression equipment, through regular carbon filter replacement.
- Decommissioning the existing trickling filters.
- Conversion of anaerobic digesters to aerobic digesters. Hydrogen sulphide is not generated as a by-product gas of this process.

Post-mitigation, there are still opportunities for odours to be generated at the proposed WWTP site; however the mitigation measures proposed are anticipated to result in a relative positive impact compared to the current WWTP operation. Odours generated at the proposed WWTP site are expected to disperse sufficiently on site so as not to cause noticeable effects on nearby residents. Odour generation will be negligible, and should not be noticed by residents.

## 8.4 Noise Impacts and Mitigation

### 8.4.1 Construction Phase

Noise and vibration will be generated to varying degrees during construction activities and have the potential to influence people in the surrounding area and local fauna. Construction noises may be expected to arise from the use and arrival of heavy equipment at the site, increased traffic, and associated construction noise. The construction phase noise is expected to be typical of heavy equipment such as trucks and backhoes, which will occur at both the existing WWTP site, as well as the locations of the collection system construction. Noise from tools, such as hammers, is expected throughout the construction phase At the WWTP site; piles will be driven intermittently throughout the first 8 months of construction.

Impacts due to construction noise will be negative and minor to moderate in magnitude.

Mitigation measures proposed include:

- Maintain vehicles and equipment.



- Keep idling of vehicles to a minimum.
- Construction activities limited to daytime hours when possible.

Residential homes neighbour the WWTP site to the north and east, and will be beside most of the collection system construction. Typically residents are not home during the weekdays. Attempting to have construction activities during daytime hours will greatly mitigate impacts due to noise in the local area. Post-mitigation, the impacts will be minor to moderate and intermittent over the short term during construction on a local scale.

#### 8.4.2 Operational Phase

During operation, noise will be generated from wastewater processes and equipment including pumps and blowers. This equipment is proposed to run continually 24/7, and has the potential to generate considerable noise. Unmitigated, this noise would affect the surrounding residents, and workers at the site. The impact would affect a minor portion of the project area population, however due to the impact that this noise would have on this population, the impact is classified as moderate.

The measures proposed in the design mitigate against the potential operational impacts of noise generation from the WWTP and lift station operations by:

- Placing pumps in enclosed buildings to minimize the amount of noise generated.
- Proposing a fine bubble aeration system that would be quieter than a surface aeration system for the bioreactor.
- Including acoustic enclosures to minimize blower noise.
- Properly maintaining and servicing equipment so that it runs properly and keeps noise to a minimum.

With these mitigation measures incorporated into the proposed design, the residual impacts are expected to be negligible off-site. This would be continuous for the long term.

### 8.5 Water Impacts and Mitigation

#### 8.5.1 Construction Phase

During the construction phase the potential exists for water quality in the project area to be affected. Runoff from construction sites, altered drainage patterns, spilled fuels and paints, or untreated wastewater or sludge entering watercourses have the potential to occur. The project design has included measures to reduce these occurrences.

##### 8.5.1.1 Land Clearing, Excavation and Storage Along Watercourses

During construction land will be cleared and excavated, which increases the potential for sedimentation as a result of:

- Soil erosion
- Possible changes to grade and drainage
- Storage of materials from stockpiles being washed into waterways



Silt runoff and sedimentation impacts resulting from construction activities associated with the collection system, lift stations and WWTP are expected to last until reforestation of the site or at exposed areas is completed or until the stream beds and banks are stabilised after construction. A possible impact is the transport of sediment away from the construction site. Depending on the original clarity of the watercourse, the flow velocity, and the column of silt that is entrained, this impact may be noticeable more than 100 m downstream of the construction site.

To mitigate this impact the following measures are proposed:

- The design of the WWTP and collection system requires that all water entering waterways from the site must have a TSS of less than 30 mg/L. An erosion control plan (**Appendix G.1**) has been developed which includes erosion control measures and bank stabilization that will assist with meeting this requirement.
- Dumping of excavated fill, waste material or debris into waterways will not be permitted.
- Stockpiles will not be located next to waterways.
- Drainage works will be constructed in accordance with the requirements of the Ministry of Works and Transport – Drainage Division.
- The contractor must submit a construction plan to WASA for approval before work in and around watercourses can occur.
- Changes from existing grading of the WWTP site will be minimized to the extent practical to minimize soil disturbance.

Post mitigation, sedimentation will be negligible.

#### *8.5.1.2 Release of Untreated Wastewater from San Fernando WWTP*

During construction of the new WWTP, the potential for release of untreated wastewater from the San Fernando WWTP and temporary sanitation facilities into the environment is a possibility, as the current equipment at the WWTP site will need to be demolished for the new equipment to be constructed. Total system bypass of the WWTP into the Ciperio River would negatively affect the Ciperio River quality over the 2 year WWTP construction period, resulting in a continuous negative impact on a local to regional scale. Although the Ciperio River water quality results already show results indicative of raw wastewater being discharged to the river, this impact would be major due to the flows to WWTP.

This would also negatively affect the existing catfish population in the area, potentially disrupting fishing activities in the Gulf of Paria close to the Ciperio River.

Accordingly, the proposed design includes construction sequencing to ensure that the WWTP remains operational throughout the entire construction period. This sequencing will allow the contents of temporary sanitation facilities to be disposed of at the septage receiving station at the WWTP site in a largely uninterrupted manner.

As the construction progresses and the new WWTP are brought online to treat wastewater an improvement in the treated effluent quality released to the Ciperio River will occur. Post-mitigation, the impact of release of untreated wastewater from the San Fernando WWTP entering the environment is negligible. This impact would occur over the construction period on a continuous scale on a local to regional scale.



## 8.5.2 Operation Phase

### 8.5.2.1 Release of Untreated Wastewater from San Fernando WWTP

Once fully constructed, all wastewater will be directed to the San Fernando WWTP. If untreated wastewater is discharged to the Ciperó River, the impact of discharging untreated wastewater to the Ciperó River would be major in magnitude.

In order to mitigate against the discharge of untreated wastewater, the design includes redundancy in a number of the WWTP processes in the event of mechanical failure. Section 3 details the redundancies, which include additional pumps and blowers, filters and UV equipment, and one additional fine screen station. With these redundancies in place, the likelihood of the WWTP having to be bypassed would be rare.

During extreme wet weather events, the impact of plant bypass has been mitigated through the design of storm water storage tanks. The tanks can hold up to 50 minutes of storage during the peak instantaneous flow to the WWTP of 158 ML/d. This storage volume is expected to contain all storms considering that the majority of the collection system will be new and I&I should be minimized. Once the storm event has subsided, the contents of the storage tanks would be gradually returned to the headworks by gravity.

With these mitigation measures incorporated, the residual impact of the proposed WWTP releasing untreated wastewater becomes negligible.

### 8.5.2.2 Water Quality Improvement

The operation of the proposed WWTP, when fully constructed, is expected to have a major positive effect on the San Fernando Project regional area water quality. This will be a long term, continuous impact. As indicated in Section 5, the water quality data from the monitored rivers within the project area indicate that untreated wastewater is currently entering the watercourses. The project, when fully constructed, will divert all untreated wastewater within the project boundaries to the new WWTP for treatment and disposal to meet the EMA Water Pollution Rules 2001 (as amended). Although some water samples upstream of the catchment did not meet the EMA Water Pollution Rules 2001 (as amended) First Schedule guidelines, there will be a major improvement to water quality when the untreated wastewater is diverted to the new WWTP for treatment and discharge.

### 8.5.2.3 Potable Water Use

During the operational phase of the WWTP, approximately 1.5m<sup>3</sup>/day of WASA supplied water will be required for domestic consumption, lab work, sinks and service water. Treated effluent, with sodium hypochlorite added, will be used for landscape watering, tank washing and line purging, which is expected to be approximately 2.0m<sup>3</sup>/day (Section 3.9).

The current San Fernando WWTP does not reuse treated effluent, and uses potable WASA supplied water for all applications. The current WWTP is on an unmetered service, so it is unknown the exact amount of water that is used at the site; however the use of WASA supplied potable water is expected to decrease at the new WWTP due to the treated effluent reuse. This results in a positive impact to potable water use.



## 8.6 Soil and Land Impacts and Mitigation

### 8.6.1 Construction Phase

#### 8.6.1.1 Erosion

During the construction period, one of the impacts that will occur is the disruption to the surface area and roads due to excavation of the roads and other surface areas. These activities are essential for installation of the collection system pipes, all underground utilities and below grade structures that are necessary for the operations of the WWTP and collection system. In open trench collection system construction, the minimum width of trenches will be:

- Pipe diameter + 3.0m for major thoroughfares and paved collector roads.
- Pipe diameter + 1.5m for secondary paved or surface treated roads and gravel roads.

Backfill material and salvaged topsoil will be temporarily stockpiled for use in the construction and re-vegetation process. Erosive action on these stockpiles and disturbed areas due to heavy precipitation and winds can result in the loss of soil resource, runoff to surface watercourses, and potential impacts to aquatic resources.

If there were open excavation during a heavy rainfall, the unmitigated negative impact could be moderate in magnitude, occurring intermittently on a regional scale.

Proposed mitigation measures include:

- Development of an erosion control specification, to be implemented by the Contractor and enforced by WASA (**Appendix G.1**).
- Construction sequencing of work, to minimize the amount of exposed sites, as detailed in Section 3.12.
- Cover or backfill trenches as soon as possible.
- Locate stockpiles away from watercourses, and minimize the amount of material stockpiled on site.

With mitigation, erosion impacts to soils during the construction phase are anticipated to be negative, negligible to minor in magnitude and to occur intermittently over the short term on a local scale.

#### 8.6.1.2 Compaction

During the construction phase, construction at the WWTP site, and collection system construction may result in soil compaction from:

- Construction equipment and machinery.
- Storage and stockpiling of materials.

This would result in a minor negative impact at the construction site and stockpile area.

Mitigation measures will include:

- Level sites and fill (if required) to restore to pre-construction grades.



Post-mitigation, this will result in a negligible impact. This will occur on a local scope intermittently throughout construction.

### 8.6.1.3 Sludge Management

Current operations of the WWTP include burying screenings, grit and sludge in localized areas on-site. This resulted in a negative impact to the soil at the WWTP site, as this solid waste should have been properly disposed of in a landfill.

To mitigate this, during construction, the existing sludge, grit and screenings at the WWTP will be removed from the sludge drying beds, and excavated from other areas at the site where these materials were previously buried. This sludge will be transported off-site to a landfill. The closest landfill is the Forres Park Landfill in Claxton Bay which is operated by the Solid Waste Management Company Limited (SWMCOL). Clean fill will replace these excavated sites. This will be a positive impact to the soil on a local scale.

### 8.6.2 Operation Phase Erosion

During the operational phase, there is potential for erosive action on soils at the effluent discharge location. Erosive action can result in soil loss and potential subsequent impacts to surface water and aquatic resources. If not properly designed this could be a moderate negative impact.

Mitigation will include designing the outfall with erosion protection. This includes the use of riprap or concrete to line the outfall channel.

Post-mitigation, the impact will be considered negligible, on a local scale, and continuous over the life of the WWTP.

## 8.7 Biological Impacts and Mitigation

### 8.7.1 Construction Phase: Flora

#### 8.7.1.1 Species Loss

During the construction phase of the proposed project, there is potential for flora species loss due to:

- Ground disturbance.
- Soil compaction from heavy equipment use.
- Clearing activities at the WWTP.
- Off-road collection system installation.

Soil compaction from construction machinery, clearing and grubbing and the general disturbance of the site will potentially negatively impact vegetation in the immediate area of the construction activities.

Approximately 350 m<sup>2</sup> of land located west of the existing WWTP fence line will be utilized for the proposed WWTP. This site is currently used to bury septage that will have to be removed and is overgrown with grasses and small bushes that will need to be removed up to the edge of the new fence line. Additional lands will also be disturbed during the collection system construction in off-road areas. Lift stations will need to be constructed, on existing WWTP and lift station sites, or new areas. Some



flora species will also be lost due to the placement of riprap or concrete at the effluent outfall location. Preservation of mangrove woodland, riparian forest and silk cotton trees is highly recommended (Comeau, 2010).

The magnitude of the negative impact could range from minor to major, and duration could be short or long term dependant on the type of vegetation that is removed.

Mitigation measures proposed include avoiding the mangrove woodland, silk cotton trees, and riparian forest to all extent possible, and containing fuel and chemical spills (Section 8.12). As indicated in Section 5, the flora observed in the project area includes low vegetation with scrub and agriculture.

- Silk cotton trees and mangrove woodland are not located on the WWTP site, although there are a few trees and bush on the northwest portion of the site that may classify as riparian. These trees will be preserved to all extent possible.
- Design of the collection system in off-road locations and lift station sites will avoid the silk cotton trees and mangrove woodland, but may disturb some riparian forest. Trenchless technology will be utilized to minimize the amount of disturbed riparian forest. Any disturbed forest will be re-established once construction is complete.

With mitigation measures, the impact due to flora species loss from construction activities is considered negligible to minor. This negative impact is on a local scale and will occur once per site on a short term basis. The predicted residual impact is reversible.

#### 8.7.1.2 *Dust Deposition*

During construction there is potential for impacts to flora due to dust deposition. Construction and decommissioning activities have the potential to generate fugitive dust emissions. Unmitigated impacts to flora due to airborne dust and particulates will be minor to negligible in magnitude.

Mitigation measures include:

- Dust suppression activities such as watering roadways and exposed ground.
- Minimizing the amount of disturbed area.
- Backfill exposed construction site as soon as possible.

Post-mitigation, the residual impacts will be negligible in magnitude.

### 8.7.2 **Construction Phase: Fauna**

#### 8.7.2.1 *Habitat Loss*

During the construction phase of the proposed project, there is potential for fauna habitat loss due to ground disturbance, soil compaction from heavy equipment use and clearing activities at the WWTP and from off-road collection system installation. As indicated previously, it is estimated that approximately 350 m<sup>2</sup> of low-value habitat typical of an overgrown empty lot will be lost due to the construction of WWTP site. For the collection system construction, areas of off-road construction may disturb habitats. Habitat loss is considered moderate.





As indicated in Section 5, there are several places in the general vicinity of the proposed WWTP site which have a far greater value for local wildlife than the proposed site. The small mangrove woodland at the mouth of Ciperó, located west of the site, is one of these locations. To mitigate the off-road collection system construction, sites will be restored as soon as possible, and trenchless technology will be used along the Marabella and Ciperó Rivers to minimize the amount of disruption.

Post-mitigation, the residual impact will be negligible to minor. The WWTP site habitat loss will be permanent (lasting the life of the facility). The habitat loss resulting from the collection system construction will occur once for short term duration but will be reversible. The impacts are considered local at the construction site.

#### 8.7.2.2 *Habitat Modification*

Habitats may be affected due to siltation from erosion activities. This could have a moderate impact on an intermittent basis.

Mitigation measures proposed include:

- Construction sequencing of work, to minimize the amount of exposed sites, as detailed in Section 3.12.
- Cover or backfill trenches as soon as possible.
- Locate stockpiles away from watercourses, and minimize the amount of material stockpiled on site.

With mitigation, impacts of habitat modifications during the construction phase are anticipated to be negative, negligible to minor in magnitude and anticipated to occur intermittently over the short term on a local scale.

#### 8.7.3 **Operation Phase: Flora**

During the operation phase of the San Fernando wastewater project, interaction with flora will include maintaining the WWTP and lift station sites to keep the grass cut and landscaping under control. This will present a negligible impact to the flora within the project area.

#### 8.7.4 **Operation Phase: Fauna**

##### 8.7.4.1 *Aquatic Fauna Species Growth*

As seen in Section 8.5.2 once the project is fully constructed, the positive impact to the water quality is expected to generate a positive impact to the aquatic fauna species through improvements to water quality. As indicated in Section 5, aquatic fauna studies returned a small sample size and low diversity of species, with one of the factors attributed to the polluted nature of the sample stations. Once fully constructed, the amount of pollution entering the waterways will be decreased, creating a more hospitable environment and result in an increase of aquatic fauna species. This results in a major regional long term positive impact.

##### 8.7.4.2 *Avifauna Habitat Modifications*

Avifauna appear to tolerate and possibly benefit from the very high nutrient content currently in the river water, and dried sludge at the existing SFWWTP. They often congregate around areas such as the



Cipero River mouth, and WWTP sludge drying beds. These birds feed on high populations of invertebrates supported by the high nutrient load but the exposure to pollutants may impact the birds' longevity and reproduction (White, 2009). With the decrease of pollutants to the waterways, and removal of sludge drying beds, fewer birds may be apparent, and may need to relocate their feeding grounds. While the distance that the avifauna may need to travel to feed could increase, resulting in a minor negative impact, the positive impact to the health of the population provides an overall positive impact to the avifauna community.

#### 8.7.4.3 Lighting

Lighting at the WWTP site will be used for security and night time maintenance, as is the current situation at the existing WWTP. This could result in a minor negative impact to the fauna around the Site.

Mitigation measures include directing the lights inside of the site, and will be as unobtrusive as possible.

Post-mitigation, the residual impact to fauna will be negligible and on a local scale.

## 8.8 Traffic Impacts and Mitigation

### 8.8.1 Construction Phase

During the construction phase of the project, there will be an increase in traffic to the WWTP site, as well as traffic disruptions when the collection system is installed in road right-of-ways.

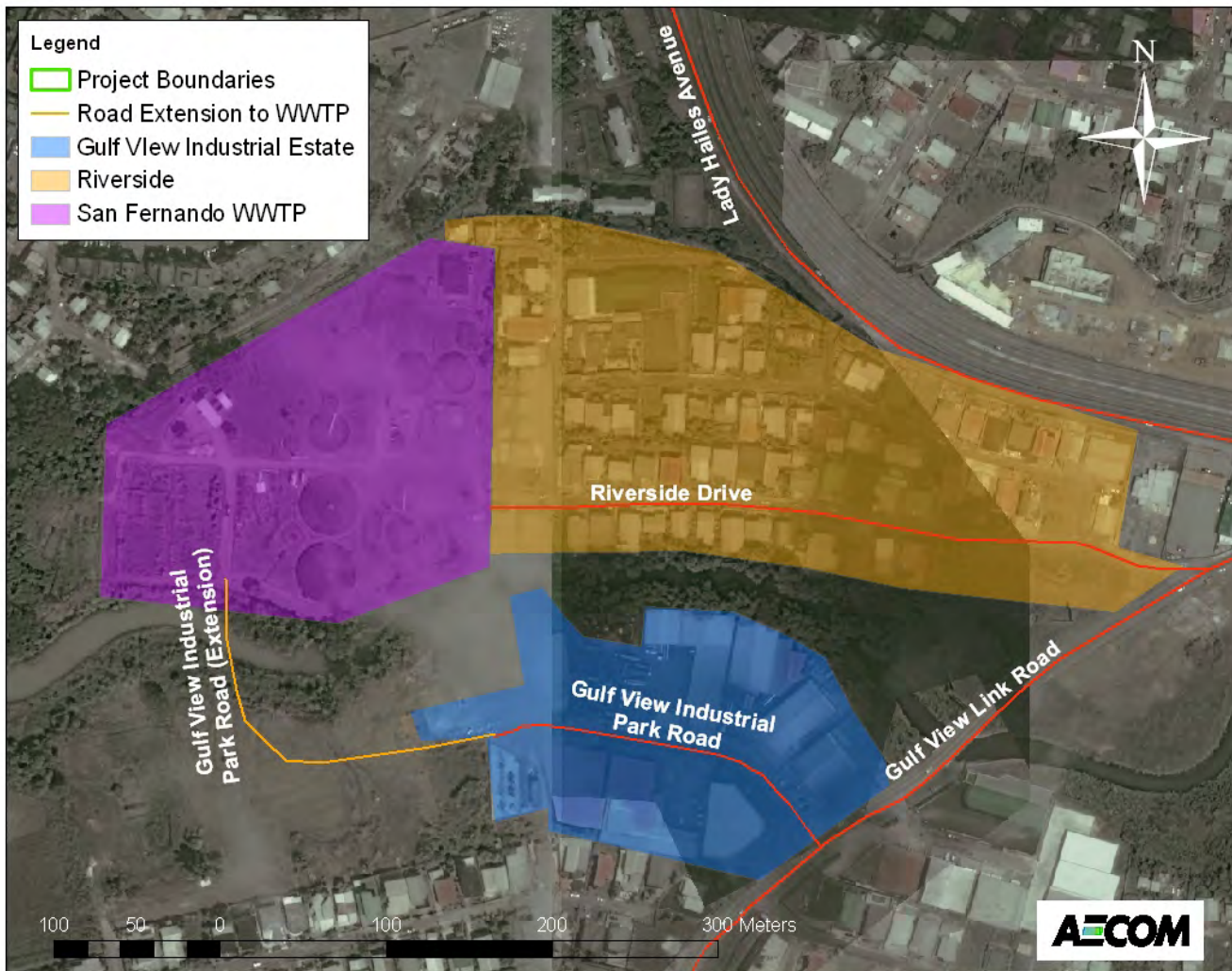
#### 8.8.1.1 WWTP Traffic

Traffic to and from the WWTP site is discussed in Section 3.12.8, and could be up to 50 vehicle trips per day. The impact and associated mitigation measures of vehicle emissions and dust to air quality are discussed in Section 8.3.1. The existing access to the WWTP is through Riverside Drive, a residential area. The increase of traffic to the site would have a medium duration impact over the 2 year construction.

This would affect a minor percentage of the project population, mainly the residents and business owners who use Riverside Drive. This impact would be continuous throughout the construction day.

To mitigate this impact, an alternate entrance to the WWTP is planned through the Gulf View Industrial Park, located south of the Cipero River. This entrance would be less disruptive to homeowners who use Riverside Drive. Carpooling to the site for workers, and regular vehicle maintenance will also be encouraged to reduce potential impacts due to the increase in traffic.

The areas impacted, pre and post-mitigation are shown in Figure 8-1. By relocating the entrance of the WWTP site, 8 businesses in the Gulf View Industrial Park will be impacted by traffic to the site, instead of 86 residential and business dwellings who utilize Riverside Drive. This traffic will still impact a minor percentage of the project population; however the affected population is lower than pre-mitigation. The construction traffic will be continuous throughout the construction day for the 2 year construction. Effects are anticipated to be local occurring throughout the construction day with effects being of short term duration and are considered reversible.



**Figure 8-1 Area of Traffic Influence of Entrance to San Fernando WWTP**

**8.8.1.2 Collection System Traffic**

Open trench collection system construction in road right-of-ways (ROW) involves closing either one lane of traffic or the entire road for construction to occur. Areas will be required for construction staging and storage of material, which may be in road ROW.

High traffic volumes on some roads in the San Fernando area mean that traffic disruptions caused by collection system construction in roadways will have a major impact to the population of the San Fernando region. The impact duration would be short term on a local scale. This short term duration construction will occur throughout the project area for the duration of the construction phase.

It was recognized early in the design process that mitigation measures for traffic would be required. Contractors will be required to submit a detailed traffic management plan and have it approved before any roadway construction commences. The traffic management plan will need to be in accordance with the traffic control specification.



### Traffic Control Specification

The traffic control specification is located in the contractor tender documents, and **Appendix G.2**. A summary of the specification follows.

### Vehicular Traffic Control

Traffic control is required for work in any ROW, including in or adjacent to streets, back lanes and highways. All road closures will need to be in accordance with the Traffic Management Plan. Provide and maintain reasonable road access and egress to properties fronting along or in vicinity of Work unless other reasonable means of road access exist.

The specific traffic control measures are dependant on the size of the road that is affected by construction. All main roads should have plans for well graded, gravelled detours or temporary roads for that are suitable for service vehicles. The main roads include:

- Solomon Hochoy Highway
- San Fernando By Pass
- South Trunk Road
- Southern Main Road
- Lady Hailes
- Naparima-Mayaro
- Tarouba Link Road
- Guaracara-Tabaquite Road
- Union Hall Road
- Ciperio Road
- Manahambre Road
- Dumfries Road
- Palmiste Blvd
- San Fernando Siparia Erin Road

On other roads where there is access from both ends, maintain local access from both ends at all times during construction. In areas where only single access exists, maintain this access to the degree possible during construction. If road closure is unavoidable, restrict to between the hours of 8:00 a.m. and 5:00 p.m. On residential streets and cul-de-sacs maintain access and/or parking between the hours of 5:00 p.m. and 8:00 a.m.

### Flag persons

Provide properly equipped flag persons, in the following situations:

- When public traffic is required to pass working vehicles or equipment which may block all or part of travelled roadway.
- When it is necessary to institute one-way traffic system through construction area or other blockage where traffic volumes are heavy, approach speeds are high and traffic signal system is not in use.
- When workers or equipment are employed on travelled way at other locations where oncoming traffic would not otherwise have adequate warning.



- Where temporary protection is required while other traffic control devices are being erected or taken down.
- For emergency protection when other traffic control devices are not readily available.
- In situations where complete protection for workers, working equipment and public traffic is not provided by other traffic control devices.

### Signage

Signs and other devices that indicate construction activities or other temporary and unusual conditions will be provided and maintained by the Contractor. This includes:

- For streets or back lanes along or in which construction is occurring, and for areas where construction vehicles are entering or leaving streets or back lanes warning signs informing traffic of construction activities ahead and restricting roadway to local traffic only.
- For roadway restricted to one way travel traffic control signs at cross streets, back lanes, and 31 m intervals between.
- For unpaved trenches and other disturbed areas in pavement flashing light barricades, to channelize traffic into undisturbed pavement.
- At cross streets and back lanes flashing light barricades, to screen off disturbed areas in trenches.
- Where permanent traffic signals disturbed by construction operation temporary traffic signals. These signals shall have same general signalling sequence and indicator arrangement as permanent signals removed except as necessary to be compatible with construction operations.
- Installation of temporary signals in other areas as necessary to protect public and aid travel of construction vehicles. Such installation shall be approved by Employers Personnel and appropriate maintaining agency.
- Provide temporary type pavement markings on replacement pavement surfaces. Markings shall match existing marking patterns. Place markings on temporary bituminous pavements, base courses of bituminous final pavements to be left more than 3 days without applying final courses, and final bituminous and concrete pavement surfaces.
- Protect drop off greater than 8 cm, but less than 16 cm within 2.5 m of pavement edge by barricades equipped with mono directional steady burn lights at 15.5 m centre to centre spacing. If drop off within 2.5m of pavement edge exceeds 8 cm. but less than .6 m, barricades shall be placed at 7.6 m centre to centre spacing. Barricades placed in excavated areas shall have leg extensions installed such that top of barricade is in compliance with height requirements of Traffic Branch.
- Placement of signs and barricades shall proceed in direction of flow of traffic. Remove signs and barricades at end of construction area and proceed toward oncoming traffic unless otherwise approved by Employers Personnel.

### Traffic Management Plan

The traffic control specification requires the contractor to prepare a detailed Traffic Management Plan including:

- A schedule of street and walkway closing, partial closings and detours.
  - Dates and duration of stages and closures.
  - Contractor's contact person(s) with 24 hour telephone number.



- Contact agencies with telephone numbers as applicable: Employer, Regional Corporation, Fire Department, Ministry of Works and Transport, Public Works Department, Police (Traffic Branch), Public Transport Service Corporation (PTSC), Trinidad and Tobago Unified Maxi Taxi Association, Schools, Hospitals, and other effected agencies.
- This schedule must remain current and be updated throughout the project.
- Procedures for pedestrian and vehicular traffic routing and protection in immediate construction area and surrounding area during working and nonworking hours.
- Plans to minimize potential traffic disruptions resulting from construction of the sewers in the roadways.
- Plans to minimize delays of public transit vehicles.
- Plans to minimize dust and mud.
- Plans to reduce the length of detours to the degree possible.

### Traffic Control Committee

A traffic control committee is required to be set up to expedite traffic control planning strategies and the necessary approval process. The committee will consist of the following parties:

- Contractor's Representative (Traffic Manager).
- Engineer.
- Employer's Representative.
- Representative from each of responsible regulatory authorities including, but not limited to the Employer, Regional Corporation, Fire Department, Ministry of Works and Transport Highways Division, Ministry of Local Government, Police (Traffic Branch), Public Transport Service Corporation (PTSC), Trinidad and Tobago Unified Maxi Taxi Association, Schools, Hospitals, and other effected agencies.
- Representatives from commercial businesses, hotels, restaurants, etc. which are affected during construction.

### Construction Phasing

The collection system will be constructed in phases based on subcatchments. A description of this activity is located in Section 3.12. By constructing in phases, the traffic impacts would be minimized to a local, short term scale.

### Trenchless Technology

To minimize the impact that open trench construction will cause in high-traffic areas, trenchless technology construction will be utilized along the following roads.

- Solomon Hochoy Highway trenchless technology used to cross the highway.
- San Fernando Bye Pass has construction off-road, and trenchless technology to cross the road.
- Tarouba Link Road has construction off-road, and trenchless technology to cross the road.
- Lady Hailes has trenchless technology construction.
- Cipero Road has trenchless technology construction.



These roads displayed high traffic counts in Section 5. By employing trenchless technology in these areas, the impact of construction would be minimized from a regional to a local scope.

#### Collection System Construction Phase Post-Mitigation

With the traffic control specification, traffic management plan, and trenchless technology construction, the post-mitigation impacts are minor to moderate in magnitude and short-term on a local scale. The frequency of impact will be continuous during construction with impacts considered reversible.

### 8.8.2 Operation Phase

As shown in Table 8-3, the anticipated traffic to the WWTP site during operation will be 56 vehicles less than the current operation of the WWTP. An alternate entrance to the WWTP to be provided through the Gulf View Industrial Park, located south of the Ciperro River. This entrance would be less disruptive to homeowners who use Riverside Drive. While this results in a positive impact to the residents and business owners who utilize Riverside Drive, businesses in the Gulf View Industrial Park will be impacted by this entrance modification.

The businesses in the Gulf View Industrial Park will experience 150 vehicles per week to the WWTP site. On a weekday, this will be approximately 28 vehicles per day. These vehicles will be staggered throughout the day, with peaks of 10-12 vehicles during the morning and afternoon, when the majority of staff will be coming and going from the site.

This will result in a negligible to minor increase in traffic in the area of Gulf View Industrial Park.

To mitigate potential effects on local business, the following measures will be encouraged:

- Staggered shifts for workers.
- Encouraging carpooling to site.

Post-mitigation, the impact on local businesses due to increased traffic in the Gulf View Industrial Park would be negligible. This impact will occur intermittently over the life of the WWTP with impacts considered reversible.

## 8.9 Social Impacts and Mitigation

### 8.9.1 Construction

#### 8.9.1.1 Use of Labour

With construction phasing, there will be employment opportunities throughout the construction period for skilled and general labour. Although employment might be temporary, it is essential that persons from the local communities with the requisite skills be given preference in terms of employment. The use of transparent and non-discriminatory hiring practices should be utilized. The increased use of local labour is considered a positive impact that will affect a minor portion of the population on a regional or island scale (if required). The employment would last for a medium duration, over the construction phase.



### 8.9.1.2 Land Acquisition

The location of the proposed San Fernando WWTP is on the site of the existing WWTP. Expansion to the west of the site is onto land also owned by WASA. Land south of the Cipero is also owned by WASA and will be used for the new access road and for construction lay down and staging.

Land will need to be acquired for the eight lift stations to be constructed. Section 3.11.1 has a description of this project activity.

While the majority of the new sewers will be constructed in public roadways, several sewer alignments will be located off-road. For these alignments it will be necessary for the construction contractor to obtain construction easements, and for WASA to obtain permanent easements for maintenance purposes.

Obtaining permanent land easements is considered a minor negative social impact as land will have development constraints associated with it for the land owner. However, as the easement process will likely involve negotiations with land owners for appropriate compensation, impacts are considered mitigated. Once the land is acquired it will be for the life of the project, on a local scale.

To mitigate the impact of acquiring land for lift stations and sewer alignments, all areas chosen are on undeveloped land or existing WWTP sites. By acquiring the existing Sunkist and Palmiste WWTP sites, these lots will be improved as they are currently abandoned and overgrown. This will result in a positive impact to these sites.

Post-mitigation, the impact of land acquisition will be negligible. This will be on a long-term duration, on a local scale.

### 8.9.1.3 Health and Injuries

Use of construction equipment and machinery on site, has the potential to impact workers or residents by generating dust and noise as well as by generating safety concerns. Dust and noise concerns will be mitigated as presented in Section 8.3.1.

Accidents are discussed in Section 8.12.

The impact of having untrained workers on a construction site (unmitigated impact), around equipment and machinery could potentially be considered a major negative impact as it could result in death or serious injury.

To prevent human health impacts, mitigation measures include:

- Hire experienced workers trained in worker health and safety.
- Educate and train workers on health and safety concerns arising from construction.
- WASA and Contractor to enforce health and safety program
- Only allowing qualified staff to operate machinery and equipment.

Post-mitigation, the impact will be minor to negligible on a local scale. Post mitigation impacts are considered reversible as it is assumed that the mitigation measures will prevent and minimize the potential for severe human health impacts during the construction phase.





#### 8.9.1.4 *Storage and Staging of Stockpiles of Materials, and Chemicals*

During construction, materials and chemicals as well as construction debris and waste may need to be stored on site. Discussions into the impacts of airborne dust and particles, and fuel and chemical spills on air, soil, and water have been discussed in previous sections. Human impacts due to accidents and malfunctions (including health hazards due to spills, trip hazards, and crush hazards) are discussed in Section 8.12.

Residents or business owners could be prevented from accessing their properties due to storing or staging of materials. Temporary visual intrusion of landscape features may also occur. This would result in a negative impact to a minor portion of the project population for a short duration.

Mitigation measures include:

- Construction site organization so as not to block any residential or businesses entry points due to storage and staging of materials. If unavoidable, provisions for alternate access must be provided.
- Keep work areas, including storage and stockpile areas tidy and limited to reasonable heights. Topsoil stockpiles not to exceed 2 m.

Post mitigation, the impact will be negligible. This would occur over a short duration on a local scale.

#### 8.9.1.5 *Use of Lighting*

During construction, some work may occur during times when lighting is required. This lighting may impact the residents located around the construction site due to daily activity disruption. The impact would be negative to a minor percentage of the project population.

To mitigate this impact, restrictions will be placed on working outside of normal daytime working hours. Where night work is necessary, construction workers will direct lights to the construction site area, and not towards resident's homes. Further, if complaints are received by local residents, WASA will work with the affected residents towards a mutually agreeable solution.

Post mitigation, the impact will be negligible. This would occur over a short duration on a local scale.

### 8.9.2 **Operation**

#### 8.9.2.1 *Use of Labour*

During the operation and maintenance of the WWTP and lift stations, the system will be operated by the contractor on a short term basis until the issuance of the Taking Over Certificate and after this time plant operations personnel will be provided by WASA.



The anticipated on-site staff needed to operate and maintain the new WWTP is as follows:

Managerial	3
Administrative support	2
Operations	6
Laboratory	2
Maintenance	5
<hr/>	<hr/>
Total	18

Additional staff will be required for maintenance of the collection system and lift stations. The anticipated field staff will include two crews each comprising a crew chief and two labourers. Their office base will be near the WWTP, possibly in a future facility located on the WASA land south of the Ciperó River. This results in a total of 24 staff.

Currently, there is 28 staff employed at the WWTP, including collection system maintenance.

This decrease to the amount of staff will have a negative impact to the four employees who will not be required anymore.

To mitigate this job loss, the four employees will be transferred to other wastewater sites or collections systems within Trinidad. WASA could also choose to operate the plant and collection system with additional staff.

This residual impact would be negligible. Workers could have a different length of time to travel to work; however it is uncertain at this time if it would be greater or less than their current situation. This would occur over the long term.

#### 8.9.2.2 Economics

With the implementation of the San Fernando Wastewater Project, water and sewer rates could have been increased in order to fund the project. This would result in a negative impact to all residents of Trinidad and Tobago who pay WASA fees. This would impact a major portion of the country.

To mitigate this impact, WASA will not be increasing their water and sewer rates due to the construction of the San Fernando Wastewater Project. Only when water rates are increased for the country as a whole then there will be an increase in sewage rates. If a resident is currently connected to WASA's sewer system, there will be no additional increase to their fees. However, some residents may experience additional costs to connect to the sewer system.

For residents who are not currently connected to WASA's sewer service, this will be an additional user fee once the project is fully constructed. Depending on how often the homeowner has their septic tank or soak-away cleaned, and considering the cost to maintain this system, the overall cost may be a neutral change, or negative change due to an increase in fees.

This post mitigation, impact may be neutral or negative for the population currently not sewered within the project boundaries. This would affect a major portion of the population within the project boundaries. The exact impact to residents would need to be studied on a per-person basis, considering the current costs of maintaining alternate wastewater containment systems.



### 8.9.2.3 Use of Lighting

The WWTP site will be a lighted site, which could negatively impact a minor portion of the project population who reside beside the site.

Mitigation measures include:

- Directing the lights inside the site.
- Installation of WireWall® fencing which will assist in blocking the light.
- If complaints are received by local residents, WASA will work with the affected residents towards a mutually agreeable solution.

Post mitigation, the impact to the local population will be negligible.

### 8.9.2.4 Water Quality Improvement

The operation phase of the project, when fully constructed, will have a major positive impact on the San Fernando Project regional area. This will be a long term, continuous impact. From a social perspective this should assist in decreasing community concerns over the environment and pollution, as seen in Section 6. With the improvement to water quality, further fishing activities may also occur, which could be an economic benefit.

## 8.10 Cumulative Impacts and Mitigation

### 8.10.1 Existing and Proposed Construction Projects

San Fernando has existing construction projects that may generate cumulative impacts to traffic and air quality, however these will need to be addressed on a case by case basis when this project begins the construction work. All new building construction within the project boundaries will be connected to the proposed wastewater collection system.

At the time of conducting the EIA Study, the National Academy of Performing Arts (NAPA) – South Centre was being constructed on Todd Street at Rienzi Kirton Highway. Construction of the collection system will occur on the north side of the Ciperio River, using trenchless technology. This is approximately 130 m from the NAPA site. Traffic and air quality impacts of the collection system construction have the potential to be cumulative with the impacts generated by the Centre construction.

In all cases where there is ongoing construction from other projects that will be in the vicinity of collection system construction, mitigation measures should include:

- Construction phasing of the collection system could be modified to bypass the area until the other project(s) are complete.
- Communication between the collection system and other project(s) contractors to determine how the projects will impact each other. All actions to be approved by WASA.
- Traffic management that considers construction traffic from the other project(s).
- Dust and noise mitigation measures shown in Section 8.3.1, will need to be closely monitored and enforced.



With the implementation of these mitigation measures, the magnitude of impact should be decreased. This will be studied individually on a case-by-case basis.

### 8.10.2 Utility Installation or Upgrade

The San Fernando wastewater project will involve excavation of roadways in order for the new collection system to be installed, which may expose other existing utilities including water, electricity, and telecommunications, and require rebuilding of drains. Working closely with these utilities and ministries could allow for upgrades of these services at the same time. This would result in a positive impact to the community, as disruptions, and construction work would only occur once for all projects.

### 8.10.3 Untreated Wastewater Discharges

As indicated from the water quality baseline sampling results, the rivers upstream of the catchment area also displayed high Faecal Coliform counts, indicative of untreated wastewater (Section 5.8). The cumulative effect of the additional wastewater entering the rivers within the San Fernando catchment area decreased the water quality further. This resulted in a major negative impact to the river water quality.

By directing all untreated wastewater within the San Fernando Project area boundaries to the proposed WWTP for proper treatment, this cumulative impact is mitigated, resulting in a major positive impact to the river water quality.

## 8.11 Summary of Impacts and Mitigation

A major positive impact from the San Fernando Wastewater Project is the improvement in surface water quality in the region, as a result of the untreated wastewater being properly collected and treated at the new WWTP. Cleaning up the waterways in the catchment area will result in a habitat improvement for aquatic species, improved public health and decrease in waterborne illnesses for humans, and overall improvement in the quality of life.

The most significant negative impact is disruption of traffic flow during construction. Traffic disruption has potential to affect over 10% of the San Fernando and environs population and will impact localized areas throughout the construction process. A significant portion of the construction will be within road right-of-ways. Mitigation of traffic impacts will be accomplished by utilizing trenchless technology in high traffic roadways, and a comprehensive traffic management plan that includes provisions for proper detours and signage, provision of access to all businesses and properties, restrictions on construction hours, and limits on the amount of construction that can occur at any one location. Once these mitigation measures are utilized in the construction, the unmitigated major negative impact becomes a mitigated minor to moderate negative impact.

A summary of the San Fernando Wastewater Project's Impacts and Mitigation measures is contained in Table 8-4.

**Table 8-4 Summary of Project Impacts and Mitigation Measures**

Classification of Potential Impact	Project Phase	Potential Impact	Unmitigated Magnitude of Impact	Mitigation Measures	Post-Mitigation						
					Residual Impact	Direction of Impact	Duration of Impact	Frequency of Impact	Scope of Impact	Degree of Reversibility	
Air Quality	Construction	Exhaust Emissions	Minor on site, negligible off site Negative	<ul style="list-style-type: none"> <li>• Carpool to site</li> <li>• Keep vehicle idling to a minimum</li> <li>• Perform vehicle inspections and maintain equipment</li> </ul>	Minor on site, Negligible off site	Negative	Medium	Continuous during working hours	Local	Reversible	
		Airborne dust and particles	Minor Negative	<ul style="list-style-type: none"> <li>• Dust suppression activities (water roads and exposed ground)</li> <li>• Minimize disturbed areas</li> <li>• Backfill exposed construction site as soon as possible - Stockpile height of topsoil maximum 2m</li> </ul>	Minor on site, Negligible off-site	Negative	Medium	Intermittent	Local	Reversible	
		Odours	Minor to Moderate Negative	<ul style="list-style-type: none"> <li>• Conduct sludge drying bed excavation when wind is directed to SW</li> <li>• Odour suppression equipment at new septage receiving station</li> <li>• Use chemicals ensuring OSHA rules are followed</li> </ul>	Negligible	Negative	Short	Intermittent to Continuous	Local	Reversible	
	Operation	Exhaust Emissions	Minor Positive	-	-	-	-	Long	Continuous	Local	-
		Airborne dust and particles	Minor Negative	<ul style="list-style-type: none"> <li>• Replacing sludge drying beds with contained processes</li> <li>• Paving WWTP Site Roads</li> <li>• Bioreactor design produces less aerosols and has additional tank freeboard</li> </ul>	Negligible	Negative	Long	Continuous	Local	Reversible	
		Odours	Minor to Moderate Negative	<ul style="list-style-type: none"> <li>• Storing screenings and grit in dumpsters instead of on the ground.</li> <li>• Covering the dumpsters used to store the screenings, grit and biosolids.</li> <li>• Ensuring all waste is hauled off-site on a scheduled and timely basis</li> <li>• Construction of a contained septage receiving station, with odour control.</li> <li>• Maintaining odour suppression equipment.</li> <li>• Decommissioning of existing trickling filters.</li> <li>• Conversion of anaerobic digesters to aerobic digesters. Hydrogen sulphide is not generated as a by-product gas of this process.</li> </ul>	Negligible	Negative	Long	Intermittent	Local	Reversible	
Noise	Construction	Noise from vehicles, equipment, and construction	Minor to Moderate Negative	<ul style="list-style-type: none"> <li>• Construction during daytime hours</li> <li>• Keep vehicle idling to a minimum</li> <li>• Design considerations including acoustic enclosures</li> <li>• Maintain vehicles and equipment</li> </ul>	Minor to Moderate	Negative	Medium	Continuous during working hours	Local	Reversible	
	Operation	Operational Noise	Moderate	<ul style="list-style-type: none"> <li>• Acoustic suppression enclosures</li> <li>• Service equipment</li> </ul>	Negligible	Negative	Long	Continuous	Local	Reversible	

**Table 8-4 Summary of Project Impacts and Mitigation Measures (continued)**

Classification of Potential Impact	Project Phase	Potential Impact	Unmitigated Magnitude of Impact	Mitigation Measures	Post-Mitigation					
					Residual Impact	Direction of Impact	Duration of Impact	Frequency of Impact	Scope of Impact	Degree of Reversibility
Water	Construction	Land Clearing and excavation along watercourses	Minor Negative	<ul style="list-style-type: none"> <li>Water from site must have TSS &lt;30 mg/L</li> <li>Erosion control blankets</li> <li>Bank stabilization</li> <li>Not allow dumping of excavated fill, waste material or debris into watercourses</li> <li>Drainage works with approval of Ministry of Works</li> </ul>	Negligible	Negative	Short	Intermittent	Local	Reversible
		Release of untreated wastewater from San Fernando WWTP	Major Negative	<ul style="list-style-type: none"> <li>Construction sequencing ensures wastewater is treated throughout construction process</li> </ul>	Negligible	Negative	Medium	Continuous	Local	Reversible
	Operation	Release of untreated wastewater from San Fernando WWTP	Major Negative	<ul style="list-style-type: none"> <li>Redundancy in WWTP design</li> <li>Storm water storage to treat through plant once storm subsides</li> </ul>	Negligible	Negative	Short	Rare	Local	Reversible
		Water Quality Improvement	Major Positive	-	-	Positive	Long	Continuous	Regional	-
		Potable Water Use	Minor Positive	-	-	Positive	Long	Continuous	Local to Regional	-
Soil	Construction	Erosion	Moderate Negative	<ul style="list-style-type: none"> <li>Construction sequencing</li> <li>Locate stockpiles away from watercourses Minimize amount of stockpiles</li> <li>Cover or backfill trenches as soon as possible</li> </ul>	Negligible to Minor	Negative	Short	Intermittent	Local	Reversible
		Soil Compaction	Minor Negative	<ul style="list-style-type: none"> <li>Level sites and fill (if required) to restore to pre-construction grades</li> </ul>	Negligible	Negative	Short	Intermittent	Local	Reversible
		Sludge Management	Minor Negative	<ul style="list-style-type: none"> <li>Excavate previously buried sludge, grit and screenings and dispose of at a landfill</li> </ul>	Negligible	Positive	Long	Once	Local	-

**Table 8-4 Summary of Project Impacts and Mitigation Measures (continued)**

Classification of Potential Impact	Project Phase	Potential Impact	Unmitigated Magnitude of Impact	Mitigation Measures	Post-Mitigation					
					Residual Impact	Direction of Impact	Duration of Impact	Frequency of Impact	Scope of Impact	Degree of Reversibility
Soil	Operation	Erosion from Outfall	Moderate Negative	<ul style="list-style-type: none"> <li>Design outfall to prevent erosion</li> <li>Maintain outfall channel construction</li> </ul>	Negligible	Negative	Long	Continuous	Local	Reversible
Flora	Construction	Species Loss	Minor to Major Negative	<ul style="list-style-type: none"> <li>Design to avoid key species</li> <li>Re-establish any riparian forest</li> </ul>	Negligible to Minor	Negative	Short to Long	Once	Local	Reversible
		Dust Deposition	Minor to Negligible Negative	<ul style="list-style-type: none"> <li>Dust suppression activities</li> <li>Minimize the amount of disturbed area</li> <li>Backfill exposed sites as soon as possible</li> </ul>	Negligible	Negative	Short	Intermittent	Local	Reversible
	Operation	Landscaping	Negligible	-	-	Neutral	Long	Intermittent	Local	-
Fauna	Construction	Habitat Loss	Moderate Negative	<ul style="list-style-type: none"> <li>Restore off road collection system construction quickly</li> <li>Use trenchless technology on some sewer construction</li> </ul>	Negligible to Minor	Negative	Short to Long	Once for collection system construction, continuous or WWTP construction	Local	Reversible
		Habitat Modification	Moderate Negative	<ul style="list-style-type: none"> <li>Restore off road collection system construction quickly</li> <li>Locate stockpiles away from watercourses</li> <li>Cover or backfill trenches as soon as possible</li> </ul>	Negligible to Minor	Negative	Short	Intermittent	Local	Reversible
	Operation	Habitat Modifications	Moderate Positive	-	-	Positive	Long	Continuous	Regional	-
		Aquatic Fauna Species Growth	Major Positive	-	-	Positive	Long	Continuous	Regional	-
		Lighting	Minor Negative	<ul style="list-style-type: none"> <li>Focus lighting within Site.</li> </ul>	Negligible	Negative	Long	Continuous during evening	Local	Reversible
Traffic	Construction	Traffic increase to site	Minor Negative	<ul style="list-style-type: none"> <li>Construct new entrance to site through Gulf View Industrial Park</li> <li>Encourage carpooling</li> </ul>	Minor	Negative	Medium	Continuous over construction day	Local	Reversible
		Traffic disruptions from collection system road right of way construction	Major Negative	<ul style="list-style-type: none"> <li>Traffic control specification.</li> <li>Traffic management plan</li> <li>Trenchless technology on high traffic roads</li> </ul>	Minor to Moderate	Negative	Short	Continuous	Local	Reversible

**Table 8-4 Summary of Project Impacts and Mitigation Measures (continued)**

Classification of Potential Impact	Project Phase	Potential Impact	Unmitigated Magnitude of Impact	Mitigation Measures	Post-Mitigation					
					Residual Impact	Direction of Impact	Duration of Impact	Frequency of Impact	Scope of Impact	Degree of Reversibility
Traffic	Operation	Traffic increase to site	Negligible to Minor Negative	<ul style="list-style-type: none"> <li>Construct new entrance to site through Gulf View Industrial Park</li> <li>Staggered shifts for workers</li> <li>Encourage carpooling</li> </ul>	Negligible	Negative	Long	Continuous	Local	Reversible
Social	Construction	Labour Requirement	Minor Positive	-	-	Positive	Medium	Continuous	Regional to National	-
		Land Acquisition	Minor Negative to Positive (site dependant)	<ul style="list-style-type: none"> <li>Acquire existing WWTP and lift station sites, and empty land</li> <li>Compensate landowners</li> </ul>	Negligible	Negative to Positive	Long	Continuous	Local	Reversible
		Health and Injuries	Minor to Major Negative	<ul style="list-style-type: none"> <li>Health and safety policy</li> <li>Only allow qualified staff to operate machinery and equipment</li> </ul>	Minor to Negligible	Negative	Short	Once to Intermittent	Local	Reversible to irreversible
		Blocked properties and visual intrusion from construction material	Minor Negative	<ul style="list-style-type: none"> <li>Construction site organization to not block access to buildings, or provide alternate access</li> <li>Keep work areas tidy and stockpiles at reasonable heights</li> </ul>	Negligible	Negative	Short	Intermittent to Continuous	Local	Reversible
	Use of lighting	Minor Negative	<ul style="list-style-type: none"> <li>Direct lights to construction site area and not towards resident's homes</li> <li>Receive and respond to resident complaints</li> </ul>	Negligible	Negative	Short	Intermittent	Local	Reversible	
	Operation	Labour Requirement	Minor Negative	<ul style="list-style-type: none"> <li>Relocate workers within WASA to other projects, or operate the plant with additional workers</li> </ul>	Negligible	Negative	Long	Continuous	Local to Regional	Reversible



**Table 8-4 Summary of Project Impacts and Mitigation Measures (continued)**

Classification of Potential Impact	Project Phase	Potential Impact	Unmitigated Magnitude of Impact	Mitigation Measures	Post-Mitigation					
					Residual Impact	Direction of Impact	Duration of Impact	Frequency of Impact	Scope of Impact	Degree of Reversibility
Social	Operation	Economics – Change to Wastewater Fees	Major for Country Negative	<ul style="list-style-type: none"> <li>No change to water rates due to project.</li> <li>Additional fee may be neutral when cost of septic tank or soakaway cleaning and maintenance is considered.</li> </ul>	Major	Neutral to Negative	Long	Continuous	Regional	Reversible
		Use of lighting	Minor	<ul style="list-style-type: none"> <li>Directing lighting inside the Site.</li> <li>Installation of WireWall® fencing to decrease light penetration</li> <li>Receive and respond to resident complaints</li> </ul>	Negligible	Negative	Long	Continuous during evenings	Local	Reversible
		Water Quality Improvement	Major Positive	-	-	Positive	Long	Continuous	Regional	-
Cumulative	Construction	Other construction projects within San Fernando Area	To be studied on a case-by-case basis throughout construction	<ul style="list-style-type: none"> <li>Construction phasing to bypass area until other project is complete</li> <li>Communication between contractors</li> <li>Traffic management plan to consider all construction</li> <li>Dust and Noise mitigation measures to be closely monitored and enforced</li> </ul>	To be studied on a case-by-case basis throughout construction	Negative	Short	To be studied on a case-by-case basis throughout construction	Local to Regional	Reversible
		Utility upgrade or installation at same time as collection system work	Minor to Major Positive	-	-	Positive	Short	Continuous	Local to Regional	-
	Operation	Water Quality Improvement	Major Positive	-	-	Positive	Long	Continuous	Regional	-



## 8.12 Accidents and Malfunctions

Accidents and malfunctions are considered any event that can occur which could potentially lead to impacts to the biophysical and social environment around and within the project area. This may be as a result of an action from the project but not necessarily a project component. The accidents and malfunctions that can occur will be discussed for all phases of the project, specifically construction, operation and decommissioning of existing facilities. The probable accidents and malfunction impacts and mitigation measures of the San Fernando Wastewater Project will be discussed according to the following themes (Table 8-5).

- Spills
- Process disruptions
- Natural disasters
- Power failures
- Fires
- Injury/death/accidents

### 8.12.1 Spills

#### 8.12.1.1 Impacts

The potential of a spill occurring is likely in all stages of the project. The spilled substance may be hazardous or non-hazardous which will include for the San Fernando Project:

- Untreated wastewater (hazardous)
- Sodium hypochlorite (hazardous)
- Polymer (non-hazardous)
- Dewatered sludge (non-hazardous)
- Fuels (hazardous)

#### Untreated Wastewater

The impact of a spillage will vary based on the characteristic of the material and the environment in which it was discharged into. Wastewater spills may occur at the WWTP and lift station sites or through a sewer main. If a wastewater spill were to occur at the WWTP, the magnitude of the impact will be negligible on-site since it would be easier to contain. However, if the wastewater spill at the WWTP flows down to the Ciperio River the impact would be moderate and may occur on a regional scale affecting all communities downstream of the River, including; Broadway and Gulf View. The effects if this were to occur are:

- Decreased river water quality
- Foul odour
- Potential human health effects

Where a wastewater spill occurs at the lift stations, the impact magnitude will vary based on location. The La Romain Central Lift Station is located near to a school and therefore the magnitude of an untreated sewage spill may be moderate but on a local scale. The effect may be the generation of a fetid odour potential for subsequent effects on the health of the students. If wastewater leaks from the



Palmiste Lift Station, because it is located within a residential area, a foul scent will be generated in conjunction with potential indirect human health impacts, for example, presence of vermin attracted to the wastewater which may also transmit diseases. The unmitigated impact is considered minor on a local scale.

If a wastewater spill occurs in any of the lift stations in Bel Air, the impact will be of the same scale typically minor with possibly a regional scale because of the close proximity to the sea, however, a spill large enough to flow into the sea is not expected. The Retrench-Golconda lift station is located near a stream but fairly distant from human civilisation, therefore if a leak occurred the effects may be experienced on a local scale if it does not seep into the river in which case the scope would be regional and a moderate magnitude.

A wastewater leak within the San Fernando Collection System is not expected to occur because the pipes would be of a good quality and installed according to best engineering practices. Nevertheless, if a pipe is fractured and wastewater leaks, the impact magnitude and scale would vary from negligible to minor on a local or regional scale because of the sewer main routes which are mainly located on roadways.

#### Sodium Hypochlorite

Sodium hypochlorite would only be stored and utilized at the WWTP. If a spill were to occur at the site, the impact would be a minor impact on a local scale. The effects of a spill would possibly only be felt by employees that would have been working close to the chemical.

#### Polymers

A polymer spillage can only potentially occur at the WWTP since during the operation phase of the project this substance will be stored and transported there. The polymer used for the process is dry polymer therefore any real impact would occur when this has been mixed and converted to a liquid form. Workers around the site of leakage may be slightly affected but the impact is expected to be negligible on a local scale.

#### Dewatered Sludge

A potential mishap can occur if the dewatered sludge falls out of the transport trucks during transit to the landfill.

The magnitude of this impact would be determined based on the area in which the sludge would have escaped however, the trucks are not expected to pass through any environmentally sensitive locations, and therefore the magnitude of impact may range from negligible to minor on a local scale.

#### Fuels

The fuels that are used for operating the construction equipment will be filled on-site via a fuel truck. There is potential for a fuel spill to occur while the equipment is being re-fuelled. The impact of this would be minor on a local scale affecting only the workers present at the re-fuelling site and the soil where the spill occurred. During a rainfall event, runoff at the site may cause the fuel to spread to nearby drains and streams. The impact of fuel runoff would then be minor in magnitude but on a regional scale.



### 8.12.1.2 Mitigation

The main measures to be implemented to prevent and reduce the effects of these potential impacts include:

- Provisions in the design for spill containment of chemicals in the storage areas.
- Design includes level meters with alarms in the wet wells, shutoff valves and backflow prevention valves to prevent overflows.
- An enforced health and safety plan that details prevention for spills including, spill kits, personal protective equipment, site maintenance and tidiness.
- Availability of Material Safety Data Sheets (MSDS) which list the characteristic of the substance and cleansing methods in the event of a spill.

In the event of wastewater and septage spillage the health and safety plan will contain emergency response procedures in case the leak does occur. The emptying and loading of trucked septage, fuel, and sludge will be done in accordance to best safety practices and will be limited to specific paved areas on the site, thus minimising the area in which a spillage might occur and the extent of damage that may be caused as a result.

Spills will be immediately cleaned using the appropriate procedure based on the substance. The flow of these chemicals into the nearby drainage will not likely occur, and will be contained through proper construction of chemical containment areas. When these mitigation measures are established and practiced the magnitude of a chemical spillage would decrease to negligible on a local scale.

## 8.12.2 Process Disruption

### 8.12.2.1 Impacts

A process disruption will be considered the malfunction of any equipment in the WWTP and lift stations apart from power failure. The impact of a process disruption is specific to the actual process breakdown and the equipment. The magnitude of the impact is indirectly affected by the piece of equipment which would have failed and the extent of damage in order for repair to occur. The impact is expected to be between a negligible and moderate impact on a local or regional scale.

### 8.12.2.2 Mitigation

The mitigation measures that will be employed in the event of a process disruption are incorporated in the WWTP and lift stations design. The design has included for redundancy in all process equipment, including extra pumps, screens, blowers, vortex grit removal chambers and additional features including dual wet wells and storage tanks. Spare parts will be stored on site. Process malfunctions will be treated with extreme attention and mitigation will be employed promptly. Operators will be on-site 24/7 to inspect the equipment and alert relevant person in these cases. Scheduled maintenance of the equipment will occur to prevent breakdown of any process equipment.

Post-mitigation, the impact is expected to be negligible to the WWTP process, and will occur for short-term durations.



### 8.12.3 Natural Hazards

#### 8.12.3.1 Impact

The possibility of a natural hazard affecting the project area is described in Section 5. The likelihood of an earthquake is moderately high with the San Fernando area being affected in the same magnitude as the rest of Trinidad with a major magnitude on a regional scale. Flooding from heavy rainfall, while a low possibility of occurrence in most of the project area (Section 5.3), the WWTP site has a high possibility of occurrence due to its location close to the mouth of the Ciperó River. If a natural hazard were to occur, this would affect the WWTP, lift stations and collection system indirectly creating a hazard to human health in the instance of spillage to wastewater or breakdown of the WWTP resulting in raw sewage discharged into the river.

#### 8.12.3.2 Mitigation

The natural hazard mitigation is instilled in the design of the San Fernando Wastewater Project. The WWTP and lift stations have been designed within the “Zone 3” Uniform Building Code based on expected seismic activity. These structures are also designed for a basic wind speed of 45 metres per second (m/s) which, according to historical storm tracks is not expected in Trinidad. The collection system is also designed with a similar approach.

Flooding of the WWTP site was also mitigated in the design phase of the project. Historical maximum river levels of the Ciperó River were obtained, as well as site visits with operators who have been employed at the current WWTP site confirmed this data. The WWTP is constructed to continue treatment throughout the high water levels of a flood.

Post-mitigation, the impact is expected to be negligible in the event of hurricane and minor the event of earthquake, or flood.

### 8.12.4 Power Failure

#### 8.12.4.1 Impacts

The potential for a power failure to occur is fairly probable and will be determined by the supplier, T&TEC. A power failure event would result in the breakdown of the WWTP and lift stations resulting in raw wastewater back up throughout the collection system with possible overflow to the Ciperó River. This could impact human health and social environment since toilets and drains could back up into homes. The impact could be major on a regional scale therefore affecting the entire project area.

#### 8.12.4.2 Mitigation

The chief mitigation measure for a power failure event is the installation of emergency standby generators which would power the total facility. There would be two generators on-site which would automatically start when the power outage occurs. These generators will be diesel driven and cooled with water and they are equipped to function for a 48 hour period. Backup power will supply 100% of the WWTP site.

Post-mitigation, the impact will be negligible on a local scale.



## 8.12.5 Fire

### 8.12.5.1 Impacts

The possibility of a fire is likely within the project area. The fire may be as a result of a process malfunction or from the spread of a nearby bush fire. The impact of a fire on the WWTP and lift stations will be based on the extent of damage. If the fire is on a small scale and only effects part of the WWTP or lift station structure, then the impact will be minor. Conversely, if the entire structure is engulfed in the fire, then the impact could be of a moderate or major magnitude on a local scale affecting the treatment process and associated works.

The impact of a fire on the sewer pipes is negligible since these structures would be underground. During construction if there is a bush fire nearby then work will have to be postponed. The impact of this would also be negligible.

### 8.12.5.2 Mitigation

The impact of a fire on the WWTP and lift stations can be mitigated by notifying employees of the contact information for the relevant fire services. An emergency response plan will also be completed where an evacuation procedure will be established for all on-duty employees. Fire drills will be carried out to ensure that the emergency response is well-known among staff.

The design of the WWTP also includes fire suppression devices in the administration and utility building. There will be a piped fire water system installed in each building where a hose will be mounted on the wall for complete coverage of the area. Portable chemical fire extinguishers will also be placed at strategic locations including:

- Points of egress
- Laboratory areas
- Kitchens
- Shop areas
- Mechanical rooms
- Electrical rooms
- Storage areas

Post-mitigation the impact of fire is expected to have a minor impact on a rare occurrence.

## 8.12.6 Injury/Death

### 8.12.6.1 Impacts

The impact of an injury will depend on the type of injury and the number of workers affected by the cause of the bodily damage. If the injury is irreversible then the magnitude may be moderate to major for one employee and major if several workers are injured permanently.

In the event of death, the impact will be major if one or more employee dies. The impact of injury or death of by-passers or ordinary persons not involved in the project must also be considered. The expectancy of an event to occur which will endanger the lives of residents not involved in the project is minimal with the implementation of the health and safety measures and other mitigation measures



presented in Section 8. However, any injury or death of a non-employee will be considered a major impact.

#### 8.12.6.2 *Mitigation*

The residual impact of injury and death of both members of staff and persons who are not employed will be reduced to negligible when the following mitigation measures are instated:

- OSH Act of Trinidad and Tobago.
- Treatment plant operator Safety, Health and Environment (SHE) Regulations.
- WASA Health, Safety and Environment (HSE) Policy.

Compliance with the OSH Act of Trinidad and Tobago will be given at all phases of the San Fernando Wastewater Project. The details of the Act are discussed in Section 2 and seek to protect employees from injury and death while on-duty. The AECOM SHE regulations is attached in **Appendix G.3** as a sample manual on ensuring health and safety of the workers are priority for all jobs undertaken by the company. WASA's HSE Policy (**Appendix G.4**) discusses emergency preparedness plans for employees as well as all institutions in place to guarantee the protection of the lives of its staff including the provision of personal protective equipment for all employees. To ensure these health and safety guidelines are followed the Contractor will be responsible for employing appropriate personnel trained in OSHA regulations to make sure the health and safety of workers are the first priority.

**Table 8-5 Summary of Accident and Malfunction Impacts and Mitigation Measures**

Classification of Potential Impact	Potential Impact	Pre-Mitigation				Mitigation Measures	Post-Mitigation			
		Magnitude of Impact	Direction of Impact	Scope of Impact	Degree of Reversibility		Duration of Impact	Frequency of Impact	Scope of Impact	Residual Impact
Spills	Sewage	Negligible to Major	Negative	Regional	Reversible	<ul style="list-style-type: none"> <li>- Maintain Equipment</li> <li>- Emergency response procedure in the event of a sewage leak</li> <li>- Emergency response procedure in the event of a septage spill</li> </ul>	Short	Rare	Local	Negligible
	Sodium Hypochlorite	Minor	Negative	Local	Reversible	<ul style="list-style-type: none"> <li>- Use of MSDS</li> <li>- Health and Safety standards for employees</li> </ul>	Short	Rare	Local	Negligible
	Polymer	Negligible	Negative	Local	Reversible	<ul style="list-style-type: none"> <li>- Use of MSDS</li> <li>- Health and Safety standards for employees</li> </ul>	Short	Rare	Local	Negligible
	Dewatered Sludge	Negligible to Minor	Negative	Local	Reversible	<ul style="list-style-type: none"> <li>- Paved designated area for sludge loading and storage</li> </ul>	Short	Rare	Local	Negligible
	Fuel	Minor	Negative	Local to Regional	Reversible	<ul style="list-style-type: none"> <li>- Paved designated area for equipment fueling</li> </ul>	Short			
Process Disruption	Malfunction of process equipment	Negligible to Moderate	Negative	Regional	Reversible	<ul style="list-style-type: none"> <li>- Scheduled maintenance of equipment</li> <li>- Operators present 24/7</li> </ul>	Short	Rare	Local	Negligible
Natural Hazards	Earthquakes	Major	Negative	Regional	Reversible	<ul style="list-style-type: none"> <li>- Construct in accordance with set earthquake-prevention building code</li> </ul>	Medium	Rare	Local	Minor
	Hurricanes	Minor	Negative	Local	Reversible	<ul style="list-style-type: none"> <li>- Design to resist and protect against high winds</li> </ul>	Short	Rare	Local	Negligible



**Table 8-5 Summary of Accident and Malfunction Impacts and Mitigation Measures (continued)**

Classification of Potential Impact	Potential Impact	Pre-Mitigation				Mitigation Measures	Post-Mitigation			
		Magnitude of Impact	Direction of Impact	Scope of Impact	Degree of Reversibility		Magnitude of Impact	Direction of Impact	Scope of Impact	Degree of Reversibility
	Flood	Major	Negative	Local	Reversible	- Design addresses high water levels and will continue treatment throughout flood event	Short	Rare	Local	Negligible
Power Failure	Shutdown of process equipment	Major	Negative	Regional	Reversible	- Install standby generators that would automatically power 100% of the site during power outages.	Short	Rare	Local	Negligible
Fire	WWTP destroyed by fire	Major	Negative	Regional	Reversible	- Emergency response plan - Routine fire drills - Fire protection system - Portable chemical extinguishers at strategic points	Short	Rare	Local	Minor
Injury/Death	Injury of Employee	Minor to Major	Negative	Local	Reversible	- PPE worn at all times	Short	Rare	Local	Minor
	Injury of non-employee	Minor to Major	Negative	Local	Reversible	- Safety and health rules from GORTT, WASA, AECOM and Contractor instilled	Short	Rare	Local	Negligible
	Death of Employee	Major	Negative	Regional	Irreversible		None	None	None	None
	Death of non-employee	Major	Negative	Regional	Irreversible	- OSH trained personnel present on site at all times	None	None	None	None



## 9. Environmental Monitoring and Management Plan

The basis for compliance monitoring will be the terms of an EMA Certificate of Environmental Clearance. The management plans need to be translated into a language appropriate for General and Particular Environmental Specifications, which will be included in the Conditions and Specifications of the Construction Contracts. It will be the responsibility of the Contractor to implement the mitigation measures associated with these specifications. WASA will retain an overriding audit function of all of its contractor activities, perform additional monitoring, and enforce compliance where needed.

WASA will appoint a designated representative of the Environmental and Regulatory Compliance Unit. This official will be responsible for ensuring the procedures for monitoring and management outlined in the CEC are adhered to for the duration of the project. The significance of the environmental monitoring and management plan is to observe progress of the project and identify any effects which may not have been previously noted.

### 9.1 Environmental Monitoring

Environmental monitoring would be conducted at the initiation of any construction activity of the site. The monitoring will be carried out through the construction phase including decommissioning of abandoned wastewater facilities. The monitoring plan will be employed throughout the operation of the WWTP, lift stations and sewer mains based on the implementation schedule. The recommended monitoring plan is presented in Table 9-1 and Table 9-2 which includes environmental, public, social and health monitoring arrangements.

Environmental monitoring as covers all aspects of the environment which will be affected by the San Fernando Wastewater Project as established in the impact assessment (Section 8). The parameters which will be screened as part of the monitoring plan are:

- Terrestrial and aquatic environment
- Air
- Noise
- Land/Soil

### 9.2 Social Monitoring

Analogous to the environmental monitoring procedures social monitoring will take place throughout all phases of the San Fernando Wastewater Project. The social impact of this project has a higher magnitude when looking at the collection system construction of the project. The following social considerations will be monitored in order to identify any impacts which may have been overlooked and the effect of the project on the particular social environment:

- Odour
- Public Health and Safety
- Traffic
- Archaeology



Apart from the plans outlined in Table 9-1 and Table 9-2, the EMA may also add or remove certain recommendations based on the need or relevance of the monitoring.

### 9.3 Management

Management of the environmental monitoring must be conducted in order to sustain the guidelines required under the monitoring plan and to ensure that the rules under which the CEC was granted are upheld. The subsequent management techniques discussed in this section will be employed to administer environmental sustainability of the San Fernando Wastewater Project.

#### 9.3.1 Environmental and Aesthetic Protection Specification

The environmental and aesthetic protection specification is appended in **Appendix H.1** and will be included in the contract documents given to the Contractor assigned to construct the San Fernando WWTP and Collection System. The specification states that the Contractor must prepare an Environmental Management Plan and a Construction Mitigation Strategy which will address impacts and mitigation methods applied in the associated works. The specification ensures that the Contractor protects the natural habitat from the works that may be carried out. The strategy employed follows specific aspects of the ecological and human environment and includes:

- Flora Protection
  - Protection of flora in areas adjacent to WWTP and collection system construction sites.
  - Removal of trees without permission.
  - Protection of designated trees.
  - Stripping of vegetation and topsoil unnecessarily.
- Archaeological Protection
  - Ensuring archaeological experts are present when excavating in areas close to Archaeological Sites.
  - Notification when an artifact is discovered to Archaeological Society.
- Drainage Protection
  - Prevention of construction material from entering watercourses.
  - Prohibiting disposal of material and water with suspended solids into watercourses.
  - Provision of appropriate structures to divert storm water and runoff.
- Erosion and Sedimentation Prevention;
  - Application of soil conservation methods such as mulching, fabric mat and sediment traps.
  - Preparation of an erosion and sediment control plan which will encompass construction sequencing relative to sedimentation, limits of disturbance, stabilisation methods used and location of a stable construction entrance.



- Waste Disposal;
  - Disposal of waste at a designated landfill.
  - Ensuring waste is approved at landfill.
  - Provision of proper containers to transport liquid waste to landfill site.
  - Prevention of dumping or burial of rubbish.
  - Provision of appropriate waste storage bins on construction site.
- Chemical and Fuel Spill Prevention;
  - Approval of all chemicals and fuels used in construction and operation by governing bodies, including obtaining permits if necessary.
  - Reporting of spills and leaks and prompt removal of spilled chemical or fuel.
  - Appropriate disposal of used oil, filter and grease cartridges and lubrication containers.
- Noise Control;
  - Compliance with NPCR where construction will only occur between 7:00 am to 7:00 pm and where the continuous and instantaneous sound level will not exceed 75 dBA and 130 dB, respectively.
  - Equip compressors and gasoline or diesel-operated equipment with silencers to minimise noise.
  - Prohibit vehicles transporting rock, slurry or concrete from public streets between 6:00 pm to 7:00 am on weekdays and anytime on Saturdays, Sundays or public holidays.
- Dust Control;
  - Ensuring site roadways, existing and utility roads are kept in clean, dust-free conditions.
  - Prevention of air pollutants contaminating air when sandblasting by using suitable temporary enclosures.
  - Covering or wetting material that can generate dust particles and air pollutants.

The document also includes details on access to the construction site, as well as parking issues. The procedure by which the Contractor must brief its employees and sub-contractor personnel is also included in the specification.

### 9.3.2 Traffic Control Specification

The traffic control specification will also be a part of the contract documents given to the Contractor (**Appendix G.2**). The employed Contractor will be required under contract to prepare a detailed Traffic Management Plan, prior to commencement of works. This plan covers vehicular traffic, pedestrian traffic and equipment transport. It is expected to comprise of a schedule of temporary road closures, and the appropriate detours to be used. The specification also outlines details of the objectives of the plan including minimising disruption to business, minimizing dust generated and delay to public transport.

A Traffic Control Committee will have to be appointed before works begin, it will comprise of the following personnel;



- Traffic Manager (appointed by the Contractor)
- Engineer
- Employees Representative (appointed by WASA)
- Representative of San Fernando City Corporation and Princes Town and Penal/Debe Regional Corporations.
- Representative of Highways Division of MOWT
- Police Officer of the Traffic Branch

The committee is expected to supervise as well as consult with residents and stakeholders to determine the convenience of the traffic management schedule.

Another significant detail of the Traffic Control Specification is implementation by the Contractor of traffic signs and other signals which should give notice or warn of;

- Construction activities ahead and restriction of roadway to local traffic only.
- Diversion of traffic from one-way travel roads at cross-streets and back lanes.
- Unpaved trenches and disturbed pavement areas by installing flashing light barricades.
- Drop off of pavement greater than 8 cm but less than 16 cm within 2.5 m of edge by using mono-directional steady burn lights.
- Drop off of pavement greater than 8 cm but less than 60 cm within 2.5 m of edge by using barricades.

The Contractor is also responsible for replacing permanent traffic signs that may have been blocked as a result of construction with temporary signs. All signs and barricades installed must be maintained to ensure eligibility and that it is within the appropriate location, all of the sign structures must be removed when construction ceases.

The Traffic Control Specification highlights the major roadways that will be affected by the San Fernando Wastewater Project and the particulars of the detour roads that can be used to divert traffic from these roadways including the dimensions of the largest possible vehicle that can utilize these detour roads. The document details of vehicular, pedestrian and construction equipment traffic the operations of vehicular traffic during working and non-working periods is also discussed. Compliance with the traffic regulations of Trinidad and Tobago and the guidelines of the Traffic Control Specification must be followed by the Contractor, Engineer and Employer of the San Fernando Wastewater Project.

### 9.3.3 Waste Management Plan

A specific waste management plan will be formulated preceding construction activities to identify the waste that would be generated as a result of the establishment of the San Fernando Wastewater Project (**Appendix H.3**). The plan would highlight reuse procedures and proper storage and disposal of waste. The waste from the construction of the WWTP and lift stations will be disposed of at a designated landfill site closest to the works. In the San Fernando area, the closest landfill is the Forres Park Landfill in Claxton Bay which is operated by the Solid Waste Management Company Limited (SWMCOL). Waste will be segregated and stored in designated storage areas before it is transported to the landfill.



The waste management during installation of the sewer mains will comprise of using the excavated material to backfill and seal the trench after the pipes are laid. Other wastes that cannot be reused to fill the trench will be disposed of using the same approach as that of the WWTP and lift stations.

The clearing of waste would be supervised by a qualified official employed by the Contractor to ensure that waste is disposed of according to the guidelines set out in the Waste Management Plan and in adherence of the Waste Management Rules, 2008.

### 9.3.4 Mitigation Action Plan

The mitigation measures discussed in Section 8 will be implemented in the appropriate project phases. It will be the responsibility of the Contractor employed by WASA to carry out the construction works as well as the Engineer hired by WASA to supervise the works to ensure that the contract is followed. The mitigation measures outlined in Table 8-4 and Table 8-5 will be transferred into specifications to be included in the San Fernando Wastewater Contract documents.

### 9.3.5 Emergency Response Plan

The possibility of the natural hazards that will affect the project area is clearly implied from the physical baseline assessment described in Section 5.3. An emergency response plan will need to be formulated by the Contractor according to the contract specifications in order to ensure the impact of a disaster is minimised or prevented. The emergency response plan will take effect prior to commencement of construction works and will be upheld throughout the operation of the San Fernando Wastewater Facilities. The plan will incorporate the response to both natural disasters and chemical spills. The importance of ensuring a disaster is prevented is asserted by the fact that sewer collection and treatment is considered a public utility.

The emergency response plan will incorporate:

- Hazard identification
- Emergency resources
- Communication systems
- Administration of the emergency response plan
- Emergency response procedure
- Communication of the procedure

## 9.4 Compliance

Compliance of the environmental monitoring and management plans is crucial to the success of the project. The Contractor will be responsible for appointing a staff to implement and oversee monitoring and management arrangements, including but not limited to:

- Traffic Control Committee
- Health and Safety Advisors
- Emergency Response Team
- Public Relation Officers



The Engineer hired by WASA to administrate the terms of the contract will be responsible for ensuring guidelines are followed and any appropriate modifications are made. The environmental monitoring will be supervised by the Environmental and Regulatory Compliance Unit at WASA.

The procedure to be followed in the event of non-compliance is immediate written notification of the breach of the terms of contract by the Engineer to the Contractor. If the notification is not regarded, a Notice of Violation will be presented to the Contractor by the Engineer clearly expounding the infringement and the procedures to be followed to uphold the contract. Where the Contractor rejects the Notice, the Engineer will inform WASA of the breach upon which disciplinary action will be taken. The disciplinary action may be a fine or even termination of the contract. The overall obligation of compliance of the environmental monitoring and management and all the terms of the CEC is the duty of WASA, through receipt of the CEC.



**Table 9-1 Monitoring Plan – Construction Phase**

Theme	Issue	Activity	Suggested Frequency	Responsibility of
Contract	Technical Specification Compliance	Audit and ensure compliance with contract specifications, CEC provisions, and worker health and safety.	Daily	Engineer
Physical Environment	River Water Quality	Visual inspection at construction sites for runoff, solid deposits or oil sheen on nearby watercourses	Daily	WASA
		Monitor turbidity levels in watercourses next to construction sites	Coincide with excavation works	
	Air Quality	Conduct TSP monitoring in communities where construction is occurring, including WWTP site. Sampling stations to be at: Site of works Nearest receptors to north, east, south, west within 1 km.	Monthly	WASA
	Noise	Conduct SPL, Leq, and Lpeak monitoring in communities where construction is occurring, including WWTP site. Sampling stations to be at: Site of works Nearest receptors to north, east, south, west within 1 km.	Monthly	WASA





**Table 9-1 Monitoring Plan – Construction Phase (continued)**

Theme	Issue	Activity	Suggested Frequency	Responsibility of
Social Environment	Traffic	Install and adhere to Traffic Control Plan.	Daily	Contractor
	Infrastructure	Ensure damage to adjacent properties is prevented. In the case of damage incidence recorded and financial compensation given.	Incidental	Contractor
	Utilities	Ensure there is no destruction to utilities. Representative from utility companies must be present at excavation site.	Incidental	Contractor
	Archaeology	In cases where archaeological site is in close proximity to earthworks arrange for member of Archaeology Society to be present. Where earthworks will be undertaken at archaeological site, excavate site prior to construction.	Incidental	Contractor
	Public Health, Safety and Social Concerns	Record all complaints received from the general public regarding dust, noise, traffic, property access and odours.	Incidental	Contractor



**Table 9-2 Monitoring Plan – Operation Phase**

Theme	Issue	Activity	Suggested Frequency	Responsibility of
Contract	WWTP and Collection System Equipment	Ensure schedule maintenance of equipment	Incidental	WASA
Physical Environment	Effluent Discharge Quality	Conduct testing of effluent discharged to receiving environment from WWTP. Conduct testing for BOD, TSS, DO, temperature, Faecal Coliform and pH	Weekly	WASA
	Aquatic Environment	Monitor Faecal Coliform counts at strategic sample points; before and after effluent discharge pipe.	Yearly	WASA
	Land/Soil/Groundwater	Regular checks of sewer mains and manholes via CCTV monitoring.	Yearly	WASA
Social Environment	Odour	Maintain odour control equipment.	Quarterly	WASA
	Noise	Conduct SPL, Leq, and Lpeak monitoring on boundary of WWTP site.	Quarterly	WASA
	Health and Safety	Conduct regular checks to ensure health and safety regulations are adhered to on-site Conduct effluent monitoring as indicated in Physical Environment section above.	Daily	WASA
	Public Concerns	Record all complaints received from the general public regarding operation of the WWTP, collection system, or lift stations.	Incidental	WASA



## 10. Bibliography

- Anonymous. (1999). *Conservation of Wildlife*. Port of Spain, Republic of Trinidad and Tobago: Legal Supplement Part C to the Trinidad and Tobago Gazette, Vol. 38, No. 34, 24th February, 1999. Printed by the Government Printer.
- Beard, J. (1946). *The Natural Vegetation of Trindiad*. Oxford: Clarendon Press.
- Central Statistical Office. (2002). *2000 Population and Housing Census: Community Register*. POS: The Ministry of Planning and Development.
- Comeau, P. (2010). *San Fernando Wastewater Project: Botanical Component*. St. Augustine.
- Construction Safety Association of Ontario. (2003). *Emergency Response Planning for Construction Projects*. Ontario.
- County of San Mateo. (2010, May). *Waste Management Plan*. Redwood City, California, USA.
- Donovan, S. (1994). *Caribbean Geology: Trinidad*. Kingston: U.W.I. Publishers Association.
- Environmental Management Authority. (2009, September). *National Environmental Policy*. Retrieved November 2009, from Environmental Management Authority:  
[http://www.ema.co.tt/cms/images/stories/pdf3/nep%2019sept05%20final%20ema%20edit%20changes%20accepted%20\(24sep09\)%20\(2\).pdf](http://www.ema.co.tt/cms/images/stories/pdf3/nep%2019sept05%20final%20ema%20edit%20changes%20accepted%20(24sep09)%20(2).pdf)
- French, R. (1997-1998). Doubtful origin in some bird species recorded in Trinidad and Tobago. *Living World, J. Trinidad & Tobago Field Naturalist's Club*, 8-12.
- Genivar. (2009). *WASA Water and Wastewater Master Plan and Policy Development*. POS: WASA.
- Marshall, R. (1934). *Physiography and vegetation of Trinidad and Tobago - a study in plant ecology*. Oxford Forest.
- Metcalf & Eddy Inc. (1991). *Wastewater Engineering: Treatment, Disposal, Reuse (Third Edition)*. USA: McGraw-Hill.
- Metcalf, E. (2003). *Wastewater Engineering: Treatment and Reuse: 4th Edition*. New York, N.Y.: The McGraw-Hill Companies.
- Minister of National Health and Welfare. (1992). *Guidelines for Canadian Recreational Water Quality*. Minister of National Health and Welfare.
- Ottley, C. (1971). The Ciperó Tramway. In *The Story of San Fernando*. POS.
- Storm CARIB Caribbean Hurricane Network. (n.d.). Retrieved April 27, 2010, from [www.stormcarib.com](http://www.stormcarib.com): [http://stormcarib.com/climatology/TTPP\\_all\\_isl.htm](http://stormcarib.com/climatology/TTPP_all_isl.htm)



Temple, S. (2002). Extinction-prone birds of Trinidad and Tobago: making predictions from theory. *Studies in Trinidad and Tobago Ornithology Honoring Richard ffrench*. , 180-193.

The Energy Chamber of T&T. (n.d.). *www.energy.tt*. Retrieved May 4, 2010, from The Energy Chamber: <http://www.energy.tt/index.php?categoryid=156>

*The University of the West Indies Seismic Research Centre*. (n.d.). Retrieved April 28, 2010, from [www.uwiseismic.com](http://www.uwiseismic.com): <http://www.uwiseismic.com/NewsDetails.aspx?id=155>

Trinidad Guardian. (1998, November 18). The History of San Fernando. p. 13.

*U.S. Environmental Protection Agency*. (n.d.). Retrieved April 30, 2010, from [www.epa.gov](http://www.epa.gov): <http://www.epa.gov/airtrends/aqtrnd95/pm10.html>

*UN Statistics Division*. (n.d.). Retrieved May 7, 2010, from <http://unstats.un.org>: <http://unstats.un.org/unsd/environmentgl/gesform.asp?getitem=936>

United Nations Food and Agriculture Organization. (2010). *Fisheries and Aquaculture Department*. Retrieved 05 13, 2010, from Country Profile, Trinidad & Tobago: [http://www.fao.org/fishery/countrysector/FI-CP\\_TT/en](http://www.fao.org/fishery/countrysector/FI-CP_TT/en)

Water Resources Agency. (2010, April 30). River Flow Data for Ciperó River.

Weather Underground Inc. (n.d.). *www.wunderground.com*. Retrieved April 12, 2010, from <http://www.wunderground.com/history/airport/TTPP/2010/4/26/CustomHistory.html>

White, G. (2009). *Habitats and Fauna of the San Fernando Wastewater Catchment Area*. Trinidad.

Wilkes University, Environmental Engineering and Earth Science Department. (n.d.). *Nitrogen - Ammonia in Water*. Retrieved May 12, 2010, from <http://www.water-research.net/Watershed/ammonia.htm>

World Health Organization. (2003). *Guidelines for Safe Recreational Water Environments: Volume I Coastal and Fresh Waters*. Geneva.